

# BATTERY

## CONTENTS

	page		page
<b>DESCRIPTION AND OPERATION</b>		<b>REMOVAL AND INSTALLATION</b>	
BATTERY .....	1	BATTERY .....	14
<b>DIAGNOSIS AND TESTING</b>		<b>SPECIFICATIONS</b>	
BATTERY .....	3	BATTERY .....	17
<b>SERVICE PROCEDURES</b>			
BATTERY CHARGING .....	12		

## DESCRIPTION AND OPERATION

### BATTERY

#### DESCRIPTION

A large capacity, low-maintenance storage battery is standard factory-installed equipment on this model. This battery is designed to provide a safe, efficient and reliable means of storing electrical energy in a chemical form. This means of energy storage allows the battery to produce the electrical energy required to operate the engine starting system, as well as to operate many of the other vehicle accessory systems for limited durations while the engine and/or the charging system are not operating.

The factory-installed low-maintenance battery has removable battery cell caps. Water can be added to this battery. The battery is not sealed and has vent holes in the cell caps (Fig. 1). The chemical composition within the low-maintenance battery reduces battery gassing and water loss, at normal charge and discharge rates.

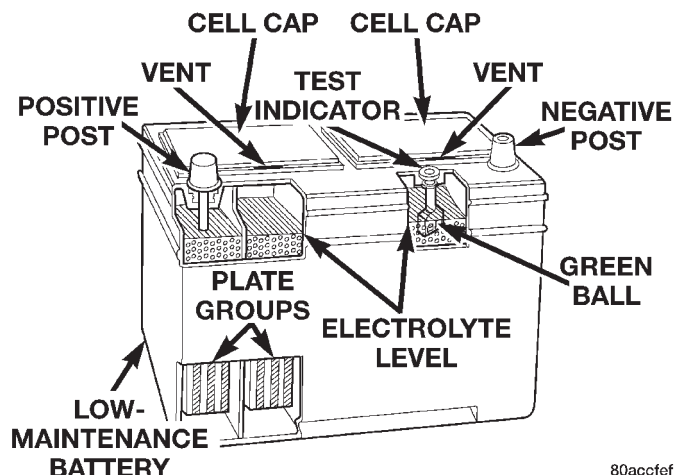

80accfef

Fig. 1 Low-Maintenance Battery - Typical

Rapid loss of electrolyte can be caused by an overcharging condition. Be certain to diagnose the charging system before returning the vehicle to service. Refer to **Charging System** in the Diagnosis and Testing section of Group 8C - Charging System for more information.

The factory-installed battery also has a built-in test indicator (hydrometer). The color visible in the sight glass of the indicator will reveal the battery condition. Refer to **Built-In Test Indicator** in the Diagnosis and Testing section of this group for more information.

This group covers only the battery diagnostic and service procedures. For battery maintenance schedules and jump starting procedures, see the owner's manual in the vehicle glove box, or refer to **Maintenance Schedules** and **Jump Starting, Towing and Hoisting** in Group 0 - Lubrication and Maintenance. While battery charging can be considered a maintenance procedure, battery charging information is located in this group. This was done because the battery must be fully-charged before any diagnosis can be performed.

Group 8A covers the Battery, Group 8B covers the Starting Systems, and Group 8C covers the Charging System. We have separated these systems to make it easier to locate the information you are seeking within this Service Manual. However, when attempting to diagnose any of these systems, it is important that you keep their interdependency in mind.

The battery, starting, and charging systems in the vehicle operate with one another, and must be tested as a complete system. In order for the vehicle to start and charge properly, all of the components that are used in these systems must perform within specifications. It is important that the battery, starting, and charging systems be thoroughly tested and inspected any time a battery needs to be charged or replaced. The cause of abnormal discharge, overcharging, or early battery failure must be diagnosed and corrected before a battery is replaced or returned to service.

## DESCRIPTION AND OPERATION (Continued)

The diagnostic procedures used in each of these groups include the most basic conventional diagnostic methods, to the more sophisticated On-Board Diagnostics (OBD) built into the Powertrain Control Module (PCM). Use of an induction-type milliampere ammeter, volt/ohmmeter, battery charger, carbon pile rheostat (load tester), and 12-volt test lamp may be required.

All OBD-sensed systems are monitored by the PCM. Each monitored circuit is assigned a Diagnostic Trouble Code (DTC). The PCM will store a DTC in electronic memory for any failure it detects. Refer to **On-Board Diagnostic Test For Charging System** in the Diagnosis and Testing section of Group 8C - Charging System for more information.

## OPERATION

The storage battery is a device used to store electrical energy potential in a chemical form. When an electrical load is applied to the battery terminals, an electrochemical reaction occurs within the battery. This reaction causes the battery to discharge electrical current.

The battery is made up of six individual cells that are connected in series. Each cell contains positively charged plate groups made of lead oxide, and negatively charged plate groups made of sponge lead. These dissimilar metal plates are submerged in a sulfuric acid and water solution called an electrolyte.

As the battery discharges, a gradual chemical change takes place within each cell. The sulfuric acid in the electrolyte combines with the plate materials, causing both plates to slowly change to lead sulfate. At the same time, oxygen from the positive plate material combines with hydrogen from the sulfuric acid, causing the electrolyte to become mainly water.

The chemical changes within the battery are caused by the movement of excess or free electrons between the positive and negative plate groups. This movement of electrons produces a flow of electrical current through the load device attached to the battery terminals.

As the plate materials become more similar chemically, and the electrolyte becomes less acid, the voltage potential of each cell is reduced. However, by charging the battery with a voltage higher than that of the battery, the battery discharging process is reversed.

Charging the battery gradually changes the sulfated lead plates back into sponge lead and lead oxide, and the water back into sulfuric acid. This action restores the difference in the electron charges deposited on the plates, and the voltage potential of the battery cells.

For a battery to remain useful, it must be able to produce high-amperage current over an extended

period. A battery must also be able to accept a charge, so that its voltage potential may be restored.

In addition to producing and storing electrical energy, the battery serves as a capacitor, or voltage stabilizer, for the electrical system of the vehicle. It absorbs most abnormal or transient voltages caused by the switching of any of the electrical components in the vehicle.

The battery is vented to release excess hydrogen gas that is created when the battery is being charged or discharged. However, even with these vents, the hydrogen gas can collect in or around the battery. If hydrogen gas is exposed to flame or sparks, it may ignite.

If the electrolyte level is low, the battery may arc internally and explode. If the battery is equipped with removable cell caps, add distilled water whenever the electrolyte level is below the top of the plates. If the battery cell caps cannot be removed, the battery must be replaced if the electrolyte level becomes low.

## BATTERY SIZE AND RATINGS

The battery Group Size number, the Cold Cranking Amperage (CCA) rating, and the Reserve Capacity (RC) rating or Ampere-Hours (AH) rating can be found on the original equipment battery label. Be certain that a replacement battery has the correct Group Size number, as well as CCA, and RC or AH ratings that equal or exceed the original equipment specification for the vehicle being serviced.

Refer to **Battery Classifications and Ratings** in the Specifications section of this group for more information. Battery sizes and ratings are discussed in more detail below.

### GROUP SIZE

The outside dimensions and terminal placement of the battery conform to standards established by the Battery Council International (BCI). Each battery is assigned a BCI Group Size number to help identify a correctly-sized replacement.

### COLD CRANKING AMPERAGE

The Cold Cranking Amperage (CCA) rating specifies how much current (in amperes) the battery can deliver for thirty seconds at  $-18^{\circ}\text{C}$  ( $0^{\circ}\text{F}$ ). Terminal voltage must not fall below 7.2 volts during or after the thirty second discharge period. The CCA required is generally higher as engine displacement increases, depending also upon the starter current draw requirements.

### RESERVE CAPACITY

The Reserve Capacity (RC) rating specifies the time (in minutes) it takes for battery terminal voltage to fall below 10.5 volts, at a discharge rate of 25

## DESCRIPTION AND OPERATION (Continued)

amperes. RC is determined with the battery fully-charged at 26.7° C (80° F). This rating estimates how long the battery might last after a charging system failure, under minimum electrical load.

## AMPERE-HOURS

The Ampere-Hours (AH) rating specifies the current (in amperes) that a battery can deliver steadily for twenty hours, with the voltage in the battery not falling below 10.5 volts. This rating is also sometimes identified as the twenty-hour discharge rating.

## MOUNTING

The battery is mounted to a molded plastic battery support located in the right front corner of the engine compartment. A U-nut is held in a formation on the inboard side of the battery support. Molded ledges near the bottom of the battery case sides are used to secure the battery in the support. First, the molded ledge on the outboard side of the battery case slides under a molded lip formation on the outboard side of the battery support. Then, a molded plastic hold down bracket is placed over the ledge on the inboard side of the battery case. Finally, a screw passes through a hole in the center of the hold down bracket and is threaded into the U-nut on the battery support, clamping the battery to the support.

The battery support is secured at the lower rear with a nut to a stud on the front wheelhouse extension panel, at the outboard side with a screw to the side cowl reinforcement panel, and at the front with a screw through a U-nut on a bracket of the radiator support. The battery support also includes three upright stanchions that are molded into the outboard side of the unit, which support the Power Distribution Center (PDC). Refer to **Power Distribution Center** in the Description and Operation section of Group 80 - Power Distribution Systems for more information on the PDC mounting.

A battery temperature sensor is snap-fit into a hole in the bottom of the battery support. Refer to **Battery Temperature Sensor** in the Description and Operation section of Group 8C - Charging System for more information on this component.

A two-piece molded plastic clam shell-type thermoguard unit encloses the sides of the battery case and helps to protect the battery from engine compartment temperature extremes. A single molded latch on each end of the thermoguard secures the unit around the battery. The thermoguard can only be removed or installed over the battery while the battery is removed from the vehicle.

When installing a battery, be certain that the hold down fastener is tightened to the proper specifications. Improper hold down fastener tightness, whether too loose or too tight, can result in damage

to the battery, the hold down bracket, and/or the battery support. Refer to **Battery** in the Removal and Installation section of this group for the correct battery hold down fastener tightness specifications.

## DIAGNOSIS AND TESTING

## BATTERY

## DIAGNOSIS

The battery, starting, and charging systems operate with one another, and must be tested as a complete system. In order for the vehicle to start and charge properly, all of the components involved in these systems must perform within specifications.

Group 8A covers the Battery, Group 8B covers the Starting Systems, and Group 8C covers the Charging System. We have separated these systems to make it easier to locate the information you are seeking within this Service Manual. However, when attempting to diagnose any of these systems, it is important that you keep their interdependency in mind.

The diagnostic procedures used in these groups include the most basic conventional diagnostic methods, to the more sophisticated On-Board Diagnostics (OBD) built into the Powertrain Control Module (PCM). Use of an induction-type milliammeter, volt/ohmmeter, battery charger, carbon pile rheostat (load tester), and 12-volt test lamp may be required.

All OBD-sensed systems are monitored by the PCM. Each monitored circuit is assigned a Diagnostic Trouble Code (DTC). The PCM will store a DTC in electronic memory for any failure it detects. Refer to **On-Board Diagnostic Test For Charging System** in the Diagnosis and Testing section of Group 8C - Charging System for more information.

The battery must be completely charged and the top, posts, and terminal clamps should be properly cleaned and inspected before diagnostic procedures are performed. Refer to **Battery** in the Removal and Installation section of this group for the proper battery cleaning and inspection procedures. Refer to **Battery Charging** in the Service Procedures section of this group for the proper charging procedures.

## DIAGNOSIS AND TESTING (Continued)

**WARNING:**

- IF THE BATTERY SHOWS SIGNS OF FREEZING, LEAKING, LOOSE POSTS, OR LOW ELECTROLYTE LEVEL, DO NOT TEST, ASSIST-BOOST, OR CHARGE. THE BATTERY MAY ARC INTERNALLY AND EXPLODE. PERSONAL INJURY AND/OR VEHICLE DAMAGE MAY RESULT.

- EXPLOSIVE HYDROGEN GAS FORMS IN AND AROUND THE BATTERY. DO NOT SMOKE, USE FLAME, OR CREATE SPARKS NEAR THE BATTERY. PERSONAL INJURY AND/OR VEHICLE DAMAGE MAY RESULT.

- THE BATTERY CONTAINS SULFURIC ACID, WHICH IS POISONOUS AND CAUSTIC. AVOID CONTACT WITH THE SKIN, EYES, OR CLOTHING. IN THE EVENT OF CONTACT, FLUSH WITH WATER AND CALL A PHYSICIAN IMMEDIATELY. KEEP OUT OF THE REACH OF CHILDREN.

- IF THE BATTERY IS EQUIPPED WITH REMOVABLE CELL CAPS, BE CERTAIN THAT EACH OF THE CELL CAPS IS IN PLACE AND TIGHT BEFORE THE BATTERY IS RETURNED TO SERVICE. PERSONAL INJURY AND/OR VEHICLE DAMAGE MAY RESULT FROM LOOSE OR MISSING CELL CAPS.

The condition of a battery is determined by two criteria:

1. **State-Of-Charge** - This can be determined by checking the specific gravity of the battery electrolyte (built-in test indicator or hydrometer test), or by checking the battery voltage (open-circuit voltage test).

2. **Cranking Capacity** - This can be determined by performing a battery load test, which measures the ability of the battery to supply high-amperage current.

First, determine the battery state-of-charge. This can be done in one of three ways. If the battery has a

built-in test indicator, view the test indicator to determine the state-of-charge. If the battery has no test indicator, but has removable cell caps, perform the hydrometer test to determine the state-of-charge. If the cell caps are not removable, or a hydrometer is not available, perform the open-circuit voltage test to determine the state-of-charge.

The battery must be charged before proceeding with a load test if:

- The battery built-in test indicator has a black or dark color visible.
- The temperature corrected specific gravity of the battery electrolyte is less than 1.235.
- The battery open-circuit voltage is less than 12.4 volts.

A battery that will not accept a charge is faulty, and must be replaced. Further testing is not required. A fully-charged battery must be load tested to determine its cranking capacity. A battery that is fully-charged, but does not pass the load test, is faulty and must be replaced.

**NOTE: Completely discharged batteries may take several hours to accept a charge. Refer to Battery Charging - Charging A Completely Discharged Battery in the Service Procedures section of this group for more information.**

A battery is fully-charged when:

- All cells are gassing freely during charging.
- A green color is visible in the sight glass of the built-in test indicator.
- Three corrected specific gravity tests, taken at one-hour intervals, indicate no increase in the specific gravity.
- Open-circuit voltage is 12.4 volts or greater.



DIAGNOSIS AND TESTING (Continued)

Battery Diagnosis		
Condition	Possible Causes	Correction
The battery seems weak or dead when attempting to start the engine.	<ol style="list-style-type: none"> <li>1. The battery has an incorrect size or rating for this vehicle.</li> <li>2. The battery is physically damaged.</li> <li>3. The battery terminal connections are loose or corroded.</li> <li>4. The battery is discharged.</li> <li>5. The electrical system ignition-off draw is excessive.</li> <li>6. The battery is faulty.</li> <li>7. The starting system is faulty.</li> <li>8. The charging system is faulty.</li> </ol>	<ol style="list-style-type: none"> <li>1. Refer to Battery in the Specifications section of this group. Replace an incorrect battery with the correct battery.</li> <li>2. Inspect the battery for loose terminal posts or a cracked and leaking case. Replace the battery, if damaged.</li> <li>3. Refer to Voltage Drop Test in the Diagnosis and Testing section of this group. Clean and tighten the battery terminal connections, if required.</li> <li>4. Determine the battery state-of-charge. Refer to Built-In Test Indicator, Hydrometer Test, or Open-Circuit Voltage Test in the Diagnosis and Testing section of this group. Charge the battery, if required.</li> <li>5. Refer to Ignition-Off Draw Test in the Diagnosis and Testing section of this group. Repair the electrical system, if required.</li> <li>6. Determine the battery cranking capacity. Refer to Load Test in the Diagnosis and Testing section of this group. Replace the battery, if required.</li> <li>7. Determine if the starting system is performing to specifications. Refer to Starting System in the Diagnosis and Testing section of Group 8B - Starting Systems for more information. Repair the starting system, if required.</li> <li>8. Determine if the charging system is performing to specifications. Refer to Charging System in the Diagnosis and Testing section of Group 8C - Charging System for more information. Repair the charging system, if required.</li> </ol>
The battery state-of-charge cannot be maintained.	<ol style="list-style-type: none"> <li>1. The battery has an incorrect size or rating for this vehicle.</li> <li>2. The battery terminal connections are loose or corroded.</li> <li>3. The generator drive belt is slipping.</li> <li>4. The electrical system ignition-off draw is excessive.</li> <li>5. The battery is faulty.</li> <li>6. The starting system is faulty.</li> <li>7. The charging system is faulty.</li> <li>8. Electrical loads exceed the output of the charging system.</li> <li>9. Slow driving or prolonged idling with high-amperage draw systems in use.</li> </ol>	<ol style="list-style-type: none"> <li>1. Refer to Battery in the Specifications section of this group. Replace an incorrect battery with the correct battery.</li> <li>2. Refer to Voltage Drop Test in the Diagnosis and Testing section of this group. Clean and tighten the battery terminal connections, if required.</li> <li>3. Refer to Accessory Drive Belt Diagnosis in the Diagnosis and Testing section of Group 7 - Cooling System for more information. Replace or adjust the generator drive belt, if required.</li> <li>4. Refer to Ignition-Off Draw Test in the Diagnosis and Testing section of this group. Repair the electrical system, if required.</li> <li>5. Determine the battery cranking capacity. Refer to Load Test in the Diagnosis and Testing section of this group. Replace the battery, if required.</li> <li>6. Determine if the starting system is performing to specifications. Refer to Starting System in the Diagnosis and Testing section of Group 8B - Starting Systems for more information. Repair the starting system, if required.</li> <li>7. Determine if the charging system is performing to specifications. Refer to Charging System in the Diagnosis and Testing section of Group 8C - Charging System for more information. Repair the charging system, if required.</li> <li>8. Inspect the vehicle for aftermarket electrical equipment which might cause excessive electrical loads.</li> <li>9. Advise the vehicle operator, as required.</li> </ol>
The battery will not accept a charge.	<ol style="list-style-type: none"> <li>1. The battery is faulty.</li> </ol>	<ol style="list-style-type: none"> <li>1. Refer to Battery Charging in the Service Procedures section of this group. Replace the faulty battery, if required.</li> </ol>

## DIAGNOSIS AND TESTING (Continued)

## ABNORMAL BATTERY DISCHARGING

Any of the following conditions can result in abnormal battery discharging:

1. Corroded or loose battery posts and terminal clamps.
2. A loose or worn generator drive belt.
3. Electrical loads that exceed the output of the charging system. This can be due to equipment installed after manufacture, or repeated short trip use.
4. Slow driving speeds (heavy traffic conditions) or prolonged idling, with high-amperage draw systems in use.
5. A faulty circuit or component causing excessive ignition-off draw. Refer to **Ignition-Off Draw Test** in the Diagnosis and Testing section of this group for more information.
6. A faulty or incorrect charging system component. Refer to **Charging System** in the Diagnosis and Testing section of Group 8C - Charging System for more information.
7. A faulty or incorrect battery.

## TESTING

## BUILT-IN TEST INDICATOR

A test indicator (hydrometer) built into the top of the battery case provides visual information for battery testing (Fig. 2). Like a hydrometer, the built-in test indicator measures the specific gravity of the electrolyte. The test indicator reveals the battery state-of-charge; however, it will not reveal the cranking capacity of the battery. A load test must be performed to determine the battery cranking capacity. Refer to **Load Test** in the Diagnosis and Testing section of this group for more information.

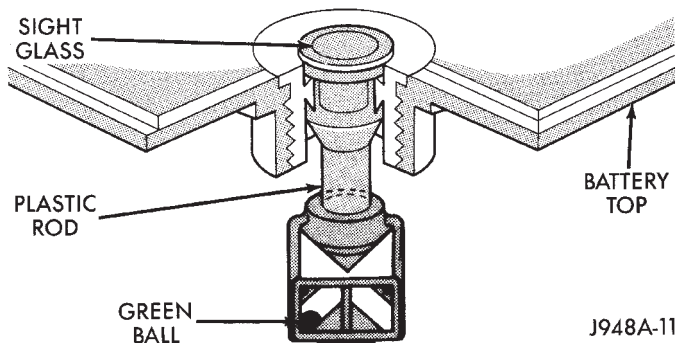

Fig. 2 Built-In Test Indicator

## WARNING:

• IF THE BATTERY SHOWS SIGNS OF FREEZING, LEAKING, LOOSE POSTS, OR LOW ELECTROLYTE LEVEL, DO NOT TEST, ASSIST-BOOST, OR CHARGE. THE BATTERY MAY ARC INTERNALLY AND EXPLODE. PERSONAL INJURY AND/OR VEHICLE DAMAGE MAY RESULT.

• EXPLOSIVE HYDROGEN GAS FORMS IN AND AROUND THE BATTERY. DO NOT SMOKE, USE FLAME, OR CREATE SPARKS NEAR THE BATTERY. PERSONAL INJURY AND/OR VEHICLE DAMAGE MAY RESULT.

• THE BATTERY CONTAINS SULFURIC ACID, WHICH IS POISONOUS AND CAUSTIC. AVOID CONTACT WITH THE SKIN, EYES, OR CLOTHING. IN THE EVENT OF CONTACT, FLUSH WITH WATER AND CALL A PHYSICIAN IMMEDIATELY. KEEP OUT OF THE REACH OF CHILDREN.

• IF THE BATTERY IS EQUIPPED WITH REMOVABLE CELL CAPS, BE CERTAIN THAT EACH OF THE CELL CAPS IS IN PLACE AND TIGHT BEFORE THE BATTERY IS RETURNED TO SERVICE. PERSONAL INJURY AND/OR VEHICLE DAMAGE MAY RESULT FROM LOOSE OR MISSING CELL CAPS.

Before testing, visually inspect the battery for any damage (a cracked case or cover, loose posts, etc.) that would cause the battery to be faulty. In order to obtain correct indications from the built-in test indicator, it is important that the battery be level and have a clean sight glass. Additional light may be required to view the indicator. **Do not use open flame as a source of additional light.**

To read the built-in test indicator, look into the sight glass and note the color of the indicator (Fig. 3). The battery condition that each color indicates is described in the following list:

• **Green** - indicates 75% to 100% state-of-charge. The battery is adequately charged for further testing or return to use. If the starter will not crank for a minimum of fifteen seconds with a fully-charged battery, the battery must be load tested. Refer to **Load Test** in the Diagnosis and Testing section of this group for more information.

• **Black or Dark** - indicates 0% to 75% state-of-charge. The battery is inadequately charged and must be charged until a green indication is visible in the sight glass (12.4 volts or more), before the battery is tested further or returned to service. Refer to **Battery Charging** in the Service Procedures section of this group for more information. Also refer to **Abnormal Battery Discharging** in the Diagnosis and Testing section of this group for possible causes of the discharged condition.

• **Clear or Bright** - indicates a low electrolyte level. The electrolyte level in the battery is below the test indicator. A maintenance-free battery with non-removable cell caps must be replaced if the electrolyte level is low. Water must be added to a low-maintenance battery with removable cell caps before it is charged. Refer to **Battery Charging** in the Service Procedures section of this group for more information. A low electrolyte level may be caused by an overcharging condition. Refer to **Charging System**

DIAGNOSIS AND TESTING (Continued)

in the Diagnosis and Testing section of Group 8C - Charging System to diagnose an overcharging condition.

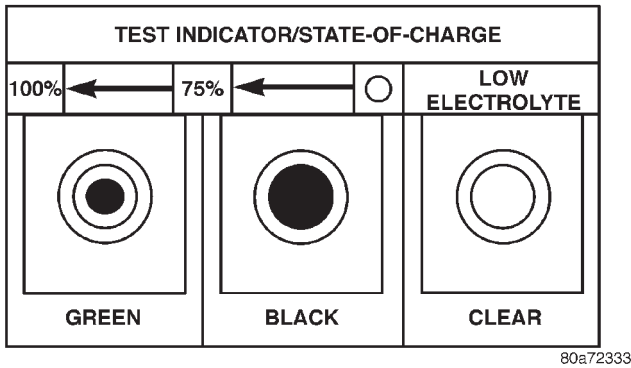

**Fig. 3 Built-In Test Indicator Sight Glass**

**HYDROMETER TEST**

The hydrometer test reveals the battery state-of-charge by measuring the specific gravity of the electrolyte. **This test cannot be performed on maintenance-free batteries with non-removable cell caps.** If the battery has non-removable cell caps, refer to **Built-In Test Indicator** or **Open-Circuit Voltage Test** in the Diagnosis and Testing section of this group.

Specific gravity is a comparison of the density of the electrolyte to the density of pure water. Pure water has a specific gravity of 1.000, and sulfuric acid has a specific gravity of 1.835. Sulfuric acid makes up approximately 35% of the electrolyte by weight, or 24% by volume.

In a fully-charged battery the electrolyte will have a temperature-corrected specific gravity of 1.260 to 1.290. However, a specific gravity of 1.235 or above is satisfactory for battery load testing and/or return to service.

**WARNING:**

- IF THE BATTERY SHOWS SIGNS OF FREEZING, LEAKING, LOOSE POSTS, OR LOW ELECTROLYTE LEVEL, DO NOT TEST, ASSIST-BOOST, OR CHARGE. THE BATTERY MAY ARC INTERNALLY AND EXPLODE. PERSONAL INJURY AND/OR VEHICLE DAMAGE MAY RESULT.

- EXPLOSIVE HYDROGEN GAS FORMS IN AND AROUND THE BATTERY. DO NOT SMOKE, USE FLAME, OR CREATE SPARKS NEAR THE BATTERY. PERSONAL INJURY AND/OR VEHICLE DAMAGE MAY RESULT.

- THE BATTERY CONTAINS SULFURIC ACID, WHICH IS POISONOUS AND CAUSTIC. AVOID CONTACT WITH THE SKIN, EYES, OR CLOTHING. IN THE EVENT OF CONTACT, FLUSH WITH WATER AND CALL A PHYSICIAN IMMEDIATELY. KEEP OUT OF THE REACH OF CHILDREN.

- IF THE BATTERY IS EQUIPPED WITH REMOVABLE CELL CAPS, BE CERTAIN THAT EACH OF THE CELL CAPS IS IN PLACE AND TIGHT BEFORE THE BATTERY IS RETURNED TO SERVICE. PERSONAL INJURY AND/OR VEHICLE DAMAGE MAY RESULT FROM LOOSE OR MISSING CELL CAPS.

Before testing, visually inspect the battery for any damage (a cracked case or cover, loose posts, etc.) that would cause the battery to be faulty. Then remove the cell caps and check the electrolyte level. Add distilled water if the electrolyte level is below the top of the battery plates.

See the instructions provided by the manufacturer of the hydrometer for recommendations on the correct use of the hydrometer that you are using. Remove only enough electrolyte from the battery cell so that the float is off the bottom of the hydrometer barrel with pressure on the bulb released.

**CAUTION:** Exercise care when inserting the tip of the hydrometer into a cell to avoid damaging the plate separators. Damaged plate separators can cause early battery failure.

To read the hydrometer correctly, hold it with the top surface of the electrolyte at eye level (Fig. 4). Hydrometer floats are generally calibrated to indicate the specific gravity correctly only at 26.7° C (80° F). When testing the specific gravity at any other temperature, a correction factor is required.

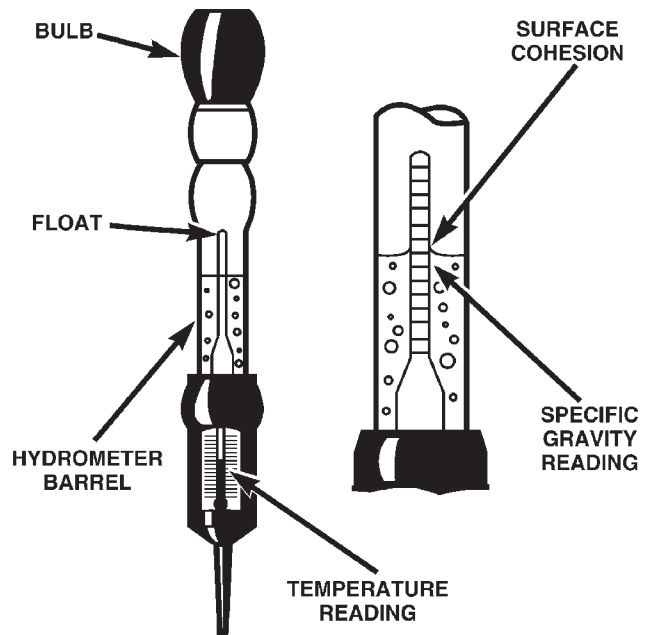

**Fig. 4 Hydrometer - Typical**

The correction factor is approximately a specific gravity value of 0.004, which may also be identified

## DIAGNOSIS AND TESTING (Continued)

as four points of specific gravity. For each 5.5° C above 26.7° C (10° F above 80° F), add four points. For each 5.5° C below 26.7° C (10° F below 80° F), subtract four points. Always correct the specific gravity for temperature variation. Test the specific gravity of the electrolyte in each battery cell.

**EXAMPLE:** A battery is tested at -12.2° C (10° F) and has a specific gravity of 1.240. Determine the actual specific gravity as follows:

(1) Determine the number of degrees above or below 26.7° C (80° F):  $26.6^{\circ}\text{C} - -12.2^{\circ}\text{C} = 38.8^{\circ}\text{C}$  ( $80^{\circ}\text{F} - 10^{\circ}\text{F} = 70^{\circ}\text{F}$ )

(2) Divide the result from Step 1 by 5.5 (10):  $38.8^{\circ}\text{C} \div 5.5 = 7$  ( $70^{\circ}\text{F} \div 10 = 7$ )

(3) Multiply the result from Step 2 by the temperature correction factor (0.004):  $7 \times 0.004 = 0.028$

(4) The temperature at testing was below 26.7° C (80° F); therefore, the temperature correction factor is subtracted:  $1.240 - 0.028 = 1.212$

The corrected specific gravity of the battery cell in this example is 1.212.

If the specific gravity of all cells is above 1.235, but the variation between cells is more than fifty points (0.050), the battery should be replaced. If the specific gravity of one or more cells is less than 1.235, charge the battery at a rate of approximately five amperes.

Continue charging the battery until three consecutive specific gravity tests, taken at one-hour intervals, are constant. If the cell specific gravity variation is more than fifty points (0.050) at the end of the charge period, replace the battery.

When the specific gravity of all cells is above 1.235, and the cell variation is less than fifty points (0.050), the battery may be load tested to determine its cranking capacity. Refer to **Load Test** in the Diagnosis and Testing section of this group for more information.

## OPEN-CIRCUIT VOLTAGE TEST

A battery open-circuit voltage (no load) test will show the state-of-charge of a battery. This test can be used in place of the hydrometer test when a hydrometer is not available, or for maintenance-free batteries with non-removable cell caps.

## WARNING:

- IF THE BATTERY SHOWS SIGNS OF FREEZING, LEAKING, LOOSE POSTS, OR LOW ELECTROLYTE LEVEL, DO NOT TEST, ASSIST-BOOST, OR CHARGE. THE BATTERY MAY ARC INTERNALLY AND EXPLODE. PERSONAL INJURY AND/OR VEHICLE DAMAGE MAY RESULT.

- EXPLOSIVE HYDROGEN GAS FORMS IN AND AROUND THE BATTERY. DO NOT SMOKE, USE FLAME, OR CREATE SPARKS NEAR THE BATTERY. PERSONAL INJURY AND/OR VEHICLE DAMAGE MAY RESULT.

- THE BATTERY CONTAINS SULFURIC ACID, WHICH IS POISONOUS AND CAUSTIC. AVOID CONTACT WITH THE SKIN, EYES, OR CLOTHING. IN THE EVENT OF CONTACT, FLUSH WITH WATER AND CALL A PHYSICIAN IMMEDIATELY. KEEP OUT OF THE REACH OF CHILDREN.

- IF THE BATTERY IS EQUIPPED WITH REMOVABLE CELL CAPS, BE CERTAIN THAT EACH OF THE CELL CAPS IS IN PLACE AND TIGHT BEFORE THE BATTERY IS RETURNED TO SERVICE. PERSONAL INJURY AND/OR VEHICLE DAMAGE MAY RESULT FROM LOOSE OR MISSING CELL CAPS.

Before proceeding with this test, completely charge the battery. Refer to **Battery Charging** in the Service Procedures section of this group for the proper battery charging procedures.

(1) Before measuring the open-circuit voltage, the surface charge must be removed from the battery. Turn on the head lamps for fifteen seconds, then allow up to five minutes for the battery voltage to stabilize.

(2) Disconnect and isolate both battery cables, negative cable first.

(3) Using a voltmeter connected to the battery posts (see the instructions provided by the manufacturer of the voltmeter), measure the open-circuit voltage (Fig. 5).

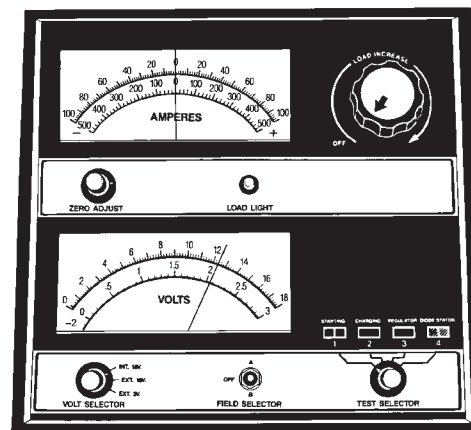

898A-7

Fig. 5 Testing Open-Circuit Voltage - Typical

See the Open-Circuit Voltage chart. This voltage reading will indicate the battery state-of-charge, but will not reveal its cranking capacity. If a battery has an open-circuit voltage reading of 12.4 volts or greater, it may be load tested to reveal its cranking capacity. Refer to **Load Test** in the Diagnosis and Testing section of this group for more information.

## LOAD TEST

A battery load test will verify the battery cranking capacity. The test is based on the Cold Cranking Amperage (CCA) rating of the battery. See the label



DIAGNOSIS AND TESTING (Continued)

Open Circuit Voltage	
Open Circuit Volts	Charge Percentage
11.7 volts or less	0%
12.0 volts	25%
12.2 volts	50%
12.4 volts	75%
12.6 volts or more	100%

affixed to the battery case, or refer to **Battery Classifications and Ratings** in the Specifications section of this group for the CCA rating of the factory-installed battery.

**WARNING:**

- IF THE BATTERY SHOWS SIGNS OF FREEZING, LEAKING, LOOSE POSTS, OR LOW ELECTROLYTE LEVEL, DO NOT TEST, ASSIST-BOOST, OR CHARGE. THE BATTERY MAY ARC INTERNALLY AND EXPLODE. PERSONAL INJURY AND/OR VEHICLE DAMAGE MAY RESULT.

- EXPLOSIVE HYDROGEN GAS FORMS IN AND AROUND THE BATTERY. DO NOT SMOKE, USE FLAME, OR CREATE SPARKS NEAR THE BATTERY. PERSONAL INJURY AND/OR VEHICLE DAMAGE MAY RESULT.

- THE BATTERY CONTAINS SULFURIC ACID, WHICH IS POISONOUS AND CAUSTIC. AVOID CONTACT WITH THE SKIN, EYES, OR CLOTHING. IN THE EVENT OF CONTACT, FLUSH WITH WATER AND CALL A PHYSICIAN IMMEDIATELY. KEEP OUT OF THE REACH OF CHILDREN.

- IF THE BATTERY IS EQUIPPED WITH REMOVABLE CELL CAPS, BE CERTAIN THAT EACH OF THE CELL CAPS IS IN PLACE AND TIGHT BEFORE THE BATTERY IS RETURNED TO SERVICE. PERSONAL INJURY AND/OR VEHICLE DAMAGE MAY RESULT FROM LOOSE OR MISSING CELL CAPS.

Before proceeding with this test, completely charge the battery. Refer to **Battery Charging** in the Service Procedures section of this group for the proper battery charging procedures.

(1) Disconnect and isolate both battery cables, negative cable first. The battery top and posts should be clean.

(2) Connect a suitable volt-ammeter-load tester (Fig. 6) to the battery posts (Fig. 7). See the instructions provided by the manufacturer of the tester you are using. Check the open-circuit voltage (no load) of the battery. Refer to **Open-Circuit Voltage Test** in the Diagnosis and Testing section of this group for the test procedures. The battery open-circuit voltage must be 12.4 volts or greater.

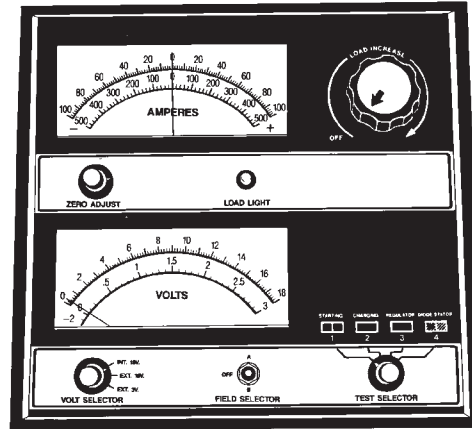

898A-8

*Fig. 6 Volt-Ammeter-Load Tester - Typical*

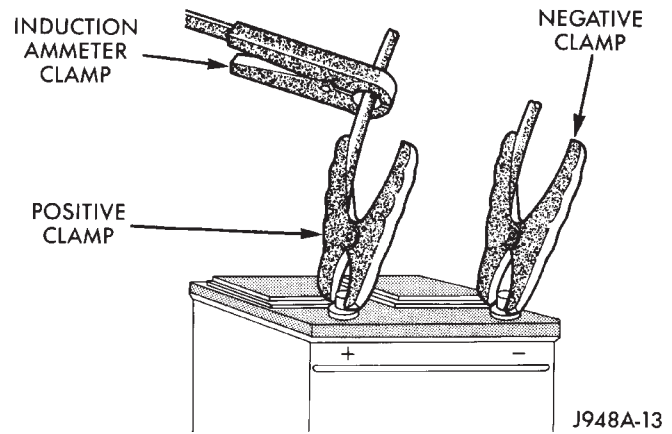

J948A-13

*Fig. 7 Volt-Ammeter-Load Tester Connections - Typical*

(3) Rotate the load control knob (carbon pile rheostat) to apply a 300 ampere load to the battery for fifteen seconds, then return the control knob to the Off position (Fig. 8). This will remove the surface charge from the battery.

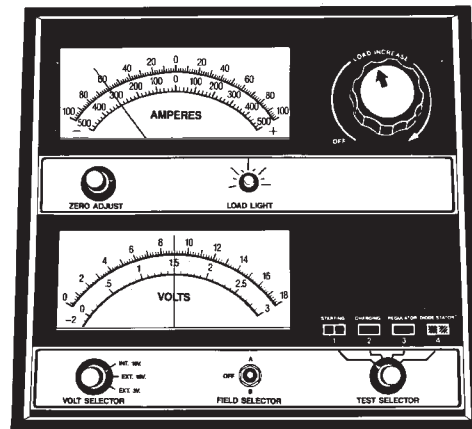

898A-10

*Fig. 8 Remove Surface Charge from Battery - Typical*

## DIAGNOSIS AND TESTING (Continued)

(4) Allow the battery to stabilize to open-circuit voltage. It may take up to five minutes for the battery voltage to stabilize.

(5) Rotate the load control knob to maintain a load equal to 50% of the CCA rating of the battery (Fig. 9). After fifteen seconds, record the loaded voltage reading, then return the load control knob to the Off position.

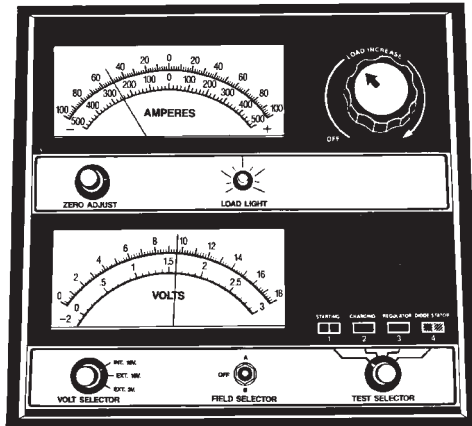

898A-11

**Fig. 9 Load 50% CCA Rating - Note Voltage - Typical**

(6) The voltage drop will vary with the battery temperature at the time of the load test. The battery temperature can be estimated by using the ambient temperature during the past several hours. If the battery has been charged, boosted, or loaded a few minutes prior to the test, the battery will be somewhat warmer. See the Load Test Temperature chart for the proper loaded voltage reading.

Load Test Temperature		
Minimum Voltage	Temperature	
	°F	°C
9.6 volts	70° and above	21° and above
9.5 volts	60°	16°
9.4 volts	50°	10°
9.3 volts	40°	4°
9.1 volts	30°	-1°
8.9 volts	20°	-7°
8.7 volts	10°	-12°
8.5 volts	0°	-18°

(7) If the voltmeter reading falls below 9.6 volts, at a minimum battery temperature of 21° C (70° F), the battery is faulty and must be replaced.

#### VOLTAGE DROP TEST

The voltage drop test will determine if there is excessive resistance in the battery terminal connections or the battery cables. When performing these

tests, it is important to remember that the voltage drop is giving an indication of the resistance between the two points at which the voltmeter probes are attached.

**Example:** When testing the resistance of the battery positive cable, touch the voltmeter leads to the battery positive cable clamp and the cable connector at the starter solenoid. If you probe the battery positive terminal post and the cable connector at the starter solenoid, you are reading the combined voltage drop in the battery positive cable clamp-to-terminal post connection and the battery positive cable.

#### WARNING:

- IF THE BATTERY SHOWS SIGNS OF FREEZING, LEAKING, LOOSE POSTS, OR LOW ELECTROLYTE LEVEL, DO NOT TEST, ASSIST-BOOST, OR CHARGE. THE BATTERY MAY ARC INTERNALLY AND EXPLODE. PERSONAL INJURY AND/OR VEHICLE DAMAGE MAY RESULT.

- EXPLOSIVE HYDROGEN GAS FORMS IN AND AROUND THE BATTERY. DO NOT SMOKE, USE FLAME, OR CREATE SPARKS NEAR THE BATTERY. PERSONAL INJURY AND/OR VEHICLE DAMAGE MAY RESULT.

- THE BATTERY CONTAINS SULFURIC ACID, WHICH IS POISONOUS AND CAUSTIC. AVOID CONTACT WITH THE SKIN, EYES, OR CLOTHING. IN THE EVENT OF CONTACT, FLUSH WITH WATER AND CALL A PHYSICIAN IMMEDIATELY. KEEP OUT OF THE REACH OF CHILDREN.

- IF THE BATTERY IS EQUIPPED WITH REMOVABLE CELL CAPS, BE CERTAIN THAT EACH OF THE CELL CAPS IS IN PLACE AND TIGHT BEFORE THE BATTERY IS RETURNED TO SERVICE. PERSONAL INJURY AND/OR VEHICLE DAMAGE MAY RESULT FROM LOOSE OR MISSING CELL CAPS.

The following operation will require a voltmeter accurate to 1/10 (0.10) volt. Before performing the tests, be certain the following procedures are accomplished:

- The battery is fully-charged. Refer to **Battery Charging** in the Service Procedures section of this group for more information.

- Fully engage the parking brake.

- If the vehicle is equipped with an automatic transmission, place the gearshift selector lever in the Park position. If the vehicle is equipped with a manual transmission, place the gearshift selector lever in the Neutral position and fully depress the clutch pedal.

- Unplug the Automatic ShutDown (ASD) relay to prevent the engine from starting. The ASD relay is located in the Power Distribution Center (PDC). Refer to the PDC label for ASD relay identification and location.

## DIAGNOSIS AND TESTING (Continued)

(1) Connect the positive lead of the voltmeter to the battery negative terminal post. Connect the negative lead of the voltmeter to the battery negative cable clamp (Fig. 10). Rotate and hold the ignition switch in the Start position. Observe the voltmeter. If voltage is detected, correct the poor contact between the cable clamp and the terminal post.

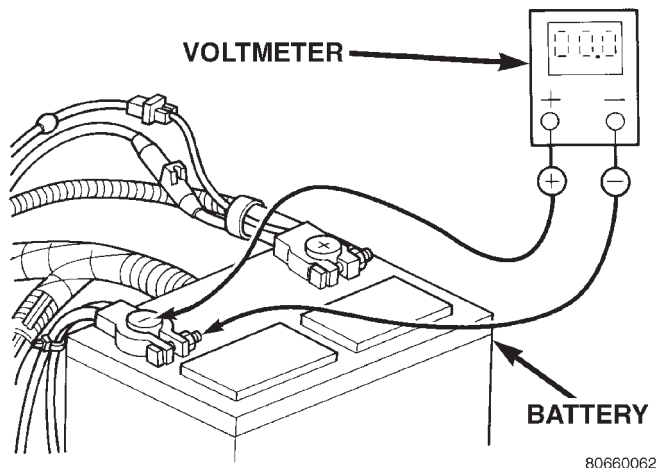

**Fig. 10 Test Battery Negative Connection Resistance - Typical**

(2) Connect the positive lead of the voltmeter to the battery positive terminal post. Connect the negative lead of the voltmeter to the battery positive cable clamp (Fig. 11). Rotate and hold the ignition switch in the Start position. Observe the voltmeter. If voltage is detected, correct the poor contact between the cable clamp and the terminal post.

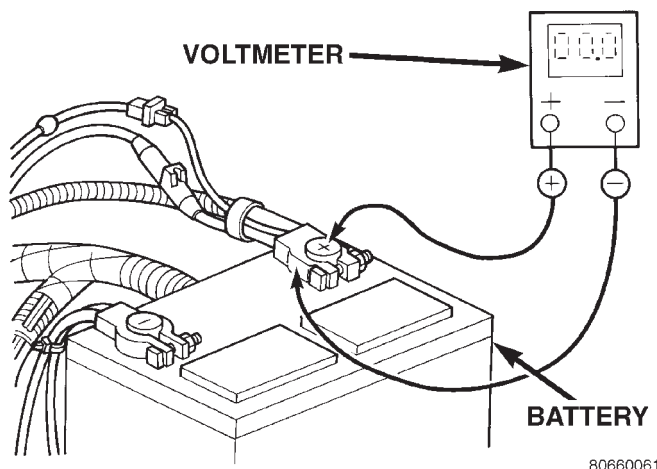

**Fig. 11 Test Battery Positive Connection Resistance - Typical**

(3) Connect the voltmeter to measure between the battery positive terminal post and the starter solenoid battery terminal stud (Fig. 12). Rotate and hold the ignition switch in the Start position. Observe the voltmeter. If the reading is above 0.2 volt, clean and

tighten the battery cable connection at the solenoid. Repeat the test. If the reading is still above 0.2 volt, replace the faulty battery positive cable.

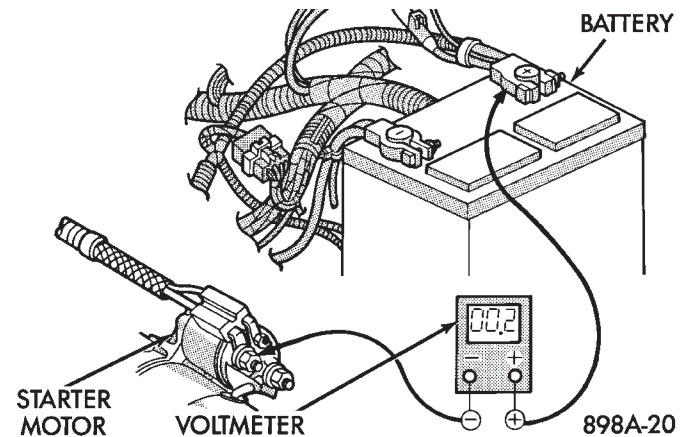

**Fig. 12 Test Battery Positive Cable Resistance - Typical**

(4) Connect the voltmeter to measure between the battery negative terminal post and a good clean ground on the engine block (Fig. 13). Rotate and hold the ignition switch in the Start position. Observe the voltmeter. If the reading is above 0.2 volt, clean and tighten the battery negative cable attachment on the engine block. Repeat the test. If the reading is still above 0.2 volt, replace the faulty battery negative cable.

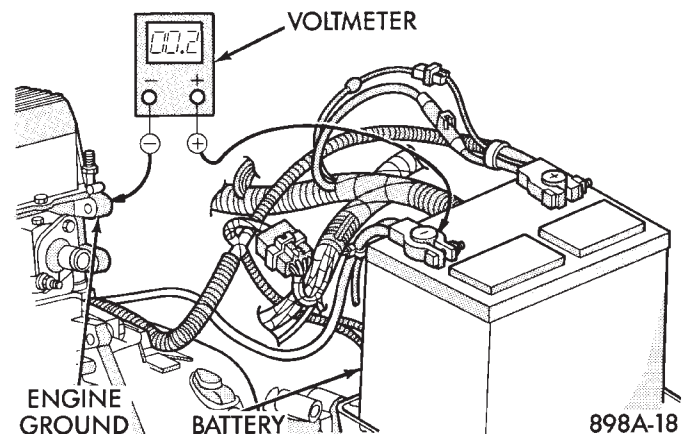

**Fig. 13 Test Ground Circuit Resistance - Typical**

## IGNITION-OFF DRAW TEST

The term Ignition-Off Draw (IOD) identifies a normal condition where power is being drained from the battery with the ignition switch in the Off position. A normal vehicle electrical system will draw from five to thirty milliamperes (0.005 to 0.030 ampere) with the ignition switch in the Off position, and all non-ignition controlled circuits in proper working order. The thirty milliamperes are needed to enable the memory functions for the Powertrain Control Module (PCM), digital clock, electronically tuned radio, and

## DIAGNOSIS AND TESTING (Continued)

other electronic modules which may vary with the vehicle equipment.

A vehicle that has not been operated for approximately twenty days, may discharge the battery to an inadequate level. When a vehicle will not be used for twenty days or more (stored), remove the IOD fuse from the junction block. This will reduce battery discharging.

Excessive IOD can be caused by:

- Electrical items left on
- Faulty or improperly adjusted switches
- Faulty or shorted electronic modules and components
- An internally shorted generator
- Intermittent shorts in the wiring.

If the IOD is over thirty milliamperes, the problem must be found and corrected before replacing a battery. In most cases, the battery can be charged and returned to service after the excessive IOD condition has been corrected.

(1) Verify that all electrical accessories are off. Turn off all lamps, remove the ignition key, and close all doors. If the vehicle is equipped with an illuminated entry system or an electronically tuned radio, allow the electronic timer function of these systems to automatically shut off (time out). This may take up to three minutes. If the vehicle is equipped with a 4.7L engine combined with a 45RFE electronic transmission, either remove the transmission fuse from the Power Distribution Center (PDC) or allow the electronic timer function of the Transmission Control Module (TCM) to automatically shut off (time out). This may take up to twenty minutes.

(2) Determine that the under-hood lamp is operating properly, then disconnect the lamp wire harness connector or remove the lamp bulb.

(3) Disconnect the battery negative cable.

(4) Set an electronic digital multi-meter to its highest amperage scale. Connect the multi-meter between the disconnected battery negative cable clamp and the battery negative terminal post. Make sure that the doors remain closed so that the illuminated entry system is not activated. The multi-meter amperage reading may remain high for up to three minutes (twenty minutes with the 45RFE transmission), or may not give any reading at all while set in the highest amperage scale, depending upon the electrical equipment on the vehicle. The multi-meter leads must be securely clamped to the battery negative cable clamp and the battery negative terminal post. If continuity between the battery negative terminal post and the negative cable clamp is lost during any part of the IOD test, the electronic timer function will be activated and all of the tests will have to be repeated.

(5) After about three minutes (twenty minutes with the 45RFE transmission), the high-amperage IOD reading on the multi-meter should become very low or nonexistent, depending upon the electrical equipment on the vehicle. If the amperage reading remains high, remove and replace each fuse or circuit breaker in the Power Distribution Center (PDC) and then in the junction block (refer to **Power Distribution Center** and **Junction Block** in the Component Index of Group 8W - Wiring Diagrams for fuse and circuit breaker identification) one at a time until the amperage reading becomes very low, or nonexistent. This will isolate each circuit and identify the source of the high-amperage IOD. If the amperage reading remains high after removing and replacing each fuse and circuit breaker, disconnect the wire harness from the generator. If the amperage reading now becomes very low or nonexistent, refer to **Charging System** in the Diagnosis and Testing section of Group 8C - Charging System to diagnose the condition. After the high-amperage IOD has been corrected, switch the multi-meter to progressively lower amperage scales and, if necessary, repeat the fuse and circuit breaker remove-and-replace process to identify and correct all sources of excessive IOD. It is now safe to select the lowest milliamperage scale of the multi-meter to check the low-amperage IOD.

**CAUTION: Do not open any doors, or turn on any electrical accessories with the lowest milliamperage scale selected, or the multi-meter may be damaged.**

(6) Observe the multi-meter reading. The low-amperage IOD should not exceed thirty milliamperes (0.030 ampere). If the draw exceeds thirty milliamperes, isolate each circuit using the fuse and circuit breaker remove-and-replace process. The multi-meter reading will drop to within the acceptable limit when the source of the excessive draw is disconnected. Repair this circuit as required; whether a wiring short, incorrect switch adjustment, or a component failure is at fault.

## SERVICE PROCEDURES

### BATTERY CHARGING

A battery is fully-charged when:

- All cells are gassing freely during battery charging.
- A green color is visible in the sight glass of the built-in test indicator.
- Three hydrometer tests, taken at one-hour intervals, indicate no increase in the temperature-corrected specific gravity.
- Open-circuit voltage is 12.4 volts or above.



## SERVICE PROCEDURES (Continued)

**WARNING:**

- IF THE BATTERY SHOWS SIGNS OF FREEZING, LEAKING, LOOSE POSTS, OR LOW ELECTROLYTE LEVEL, DO NOT TEST, ASSIST-BOOST, OR CHARGE. THE BATTERY MAY ARC INTERNALLY AND EXPLODE. PERSONAL INJURY AND/OR VEHICLE DAMAGE MAY RESULT.

- EXPLOSIVE HYDROGEN GAS FORMS IN AND AROUND THE BATTERY. DO NOT SMOKE, USE FLAME, OR CREATE SPARKS NEAR THE BATTERY. PERSONAL INJURY AND/OR VEHICLE DAMAGE MAY RESULT.

- THE BATTERY CONTAINS SULFURIC ACID, WHICH IS POISONOUS AND CAUSTIC. AVOID CONTACT WITH THE SKIN, EYES, OR CLOTHING. IN THE EVENT OF CONTACT, FLUSH WITH WATER AND CALL A PHYSICIAN IMMEDIATELY. KEEP OUT OF THE REACH OF CHILDREN.

- IF THE BATTERY IS EQUIPPED WITH REMOVABLE CELL CAPS, BE CERTAIN THAT EACH OF THE CELL CAPS IS IN PLACE AND TIGHT BEFORE THE BATTERY IS RETURNED TO SERVICE. PERSONAL INJURY AND/OR VEHICLE DAMAGE MAY RESULT FROM LOOSE OR MISSING CELL CAPS.

**CAUTION:**

- Always disconnect and isolate the battery negative cable before charging a battery. Do not exceed sixteen volts while charging a battery. Damage to the vehicle electrical system components may result.

- Battery electrolyte will bubble inside the battery case during normal battery charging. Electrolyte boiling or being discharged from the battery vents indicates a battery overcharging condition. Immediately reduce the charging rate or turn off the charger to evaluate the battery condition. Damage to the battery may result from overcharging.

- The battery should not be hot to the touch. If the battery feels hot to the touch, turn off the charger and let the battery cool before continuing the charging operation. Damage to the battery may result.

Some battery chargers are equipped with polarity-sensing circuitry. This circuitry protects the charger and/or the battery from being damaged if they are improperly connected. If the battery state-of-charge is too low for the polarity-sensing circuitry to detect, the charger will not operate. This makes it appear that the battery will not accept charging current. See the instructions provided by the manufacturer of the battery charger for details on how to bypass the polarity-sensing circuitry.

After the battery has been charged to 12.4 volts or greater, perform a load test to determine the battery

cranking capacity. Refer to **Load Test** in the Diagnosis and Testing section of this group for the procedures. If the battery will endure a load test, return the battery to use. If the battery will not endure a load test, it is faulty and must be replaced.

Clean and inspect the battery hold downs, tray, terminals, posts, and top before completing service. Refer to **Battery** in the Removal and Installation section of this group for the proper cleaning and inspection procedures.

**CHARGING A COMPLETELY DISCHARGED BATTERY**

The following procedure should be used to recharge a completely discharged battery. Unless this procedure is properly followed, a good battery may be needlessly replaced.

(1) Measure the voltage at the battery posts with a voltmeter, accurate to 1/10 (0.10) volt (Fig. 14). If the reading is below ten volts, the charge current will be low. It could take some time before the battery accepts a current greater than a few milliamperes. Such low current may not be detectable on the ammeters built into many battery chargers.

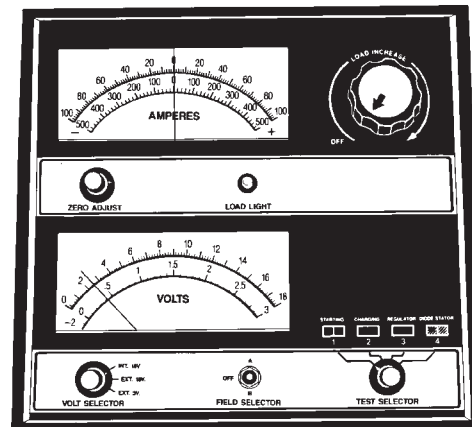

898A-12

**Fig. 14 Voltmeter Accurate to 1/10 Volt Connected - Typical**

(2) Disconnect and isolate the battery negative cable. Connect the battery charger leads. Some battery chargers are equipped with polarity-sensing circuitry. This circuitry protects the charger and/or the battery from being damaged if they are improperly connected. If the battery state-of-charge is too low for the polarity-sensing circuitry to detect, the charger will not operate. This makes it appear that the battery will not accept charging current. See the instructions provided by the manufacturer of the battery charger for details on how to bypass the polarity-sensing circuitry.

(3) Battery chargers vary in the amount of voltage and current they provide. The amount of time required for a battery to accept measurable charger

## SERVICE PROCEDURES (Continued)

current at various voltages is shown in the Charge Rate chart. If the charge current is still not measurable at the end of the charging time, the battery is faulty and must be replaced. If the charge current is measurable during the charging time, the battery may be good and the charging should be completed in the normal manner.

Charge Rate	
Voltage	Hours
16.0 volts maximum	up to 4 hours
14.0 to 15.9 volts	up to 8 hours
13.9 volts or less	up to 16 hours

## CHARGING TIME REQUIRED

The time required to charge a battery will vary, depending upon the following factors:

- **Battery Capacity** - A completely discharged heavy-duty battery requires twice the charging time of a small capacity battery.
- **Temperature** - A longer time will be needed to charge a battery at  $-18^{\circ}\text{C}$  ( $0^{\circ}\text{F}$ ) than at  $27^{\circ}\text{C}$  ( $80^{\circ}\text{F}$ ). When a fast charger is connected to a cold battery, the current accepted by the battery will be very low at first. As the battery warms, it will accept a higher charging current rate (amperage).
- **Charger Capacity** - A battery charger that supplies only five amperes will require a longer charging time. A battery charger that supplies twenty amperes or more will require a shorter charging time.
- **State-Of-Charge** - A completely discharged battery requires more charging time than a partially discharged battery. Electrolyte is nearly pure water in a completely discharged battery. At first, the charging current (amperage) will be low. As the battery charges, the specific gravity of the electrolyte will gradually rise.

**WARNING: NEVER EXCEED TWENTY AMPERES WHEN CHARGING A COLD ( $-1^{\circ}\text{C}$  or  $30^{\circ}\text{F}$ ) BATTERY. THE BATTERY MAY ARC INTERNALLY AND EXPLODE. PERSONAL INJURY AND/OR VEHICLE DAMAGE MAY RESULT.**

## REMOVAL AND INSTALLATION

## BATTERY

## REMOVAL

(1) Turn the ignition switch to the Off position. Be certain that all electrical accessories are turned off.

Battery Charging Timetable			
Charging Amperage	5 Amperes	10 Amperes	20 Amperes
Open Circuit Voltage	Hours Charging at $21^{\circ}\text{C}$ ( $70^{\circ}\text{F}$ )		
12.25 to 12.49	6 hours	3 hours	1.5 hours
12.00 to 12.24	10 hours	5 hours	2.5 hours
10.00 to 11.99	14 hours	7 hours	3.5 hours
*Below 10.00	18 hours	9 hours	4.5 hours
*Refer to Charging A Completely Discharged Battery			

(2) Loosen the battery cable terminal clamp nuts and disconnect both battery cables, negative cable first. If necessary, use a puller to remove the terminal clamps from the battery posts (Fig. 15).

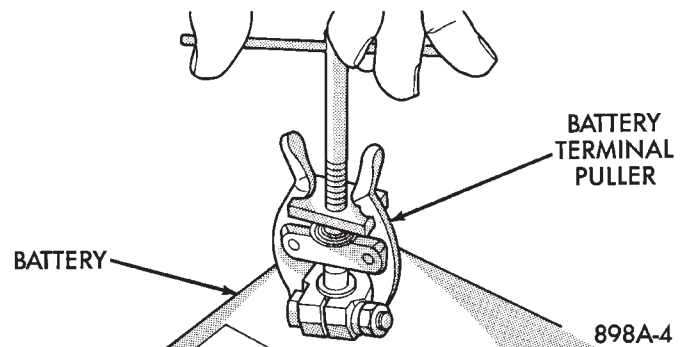

**Fig. 15 Remove Battery Cable Terminal Clamp - Typical**

(3) Inspect the battery cable terminal clamps for corrosion and damage. Remove any corrosion using a wire brush or a post and terminal cleaning tool, and a sodium bicarbonate (baking soda) and warm water cleaning solution (Fig. 16). Replace any battery cable that has damaged or deformed terminal clamps.

**WARNING: WEAR A SUITABLE PAIR OF RUBBER GLOVES (NOT THE HOUSEHOLD TYPE) WHEN REMOVING A BATTERY BY HAND. SAFETY GLASSES SHOULD ALSO BE WORN. IF THE BATTERY IS CRACKED OR LEAKING, THE ELECTROLYTE CAN BURN THE SKIN AND EYES.**

(4) Remove the battery hold down bracket screw (Fig. 17) and remove the bracket from the battery support.

(5) Remove the battery and thermoguard unit from the battery support.

REMOVAL AND INSTALLATION (Continued)

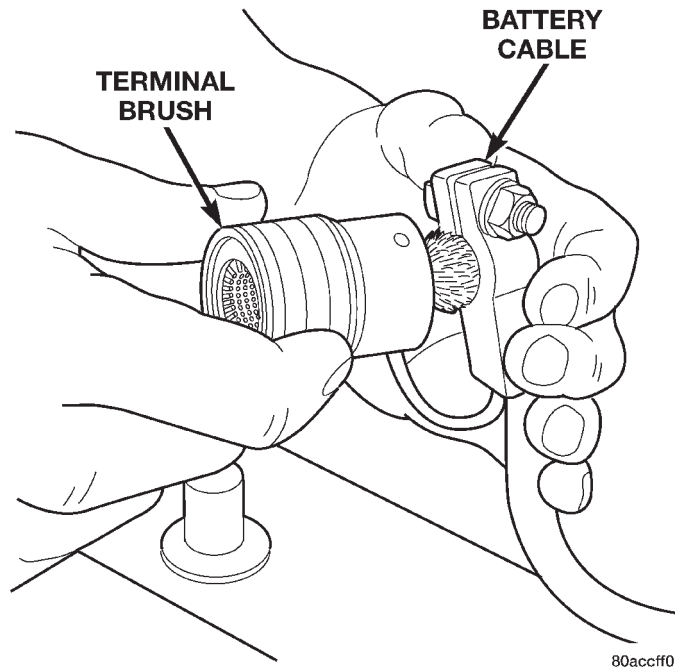

**Fig. 16 Clean Battery Cable Terminal Clamp - Typical**

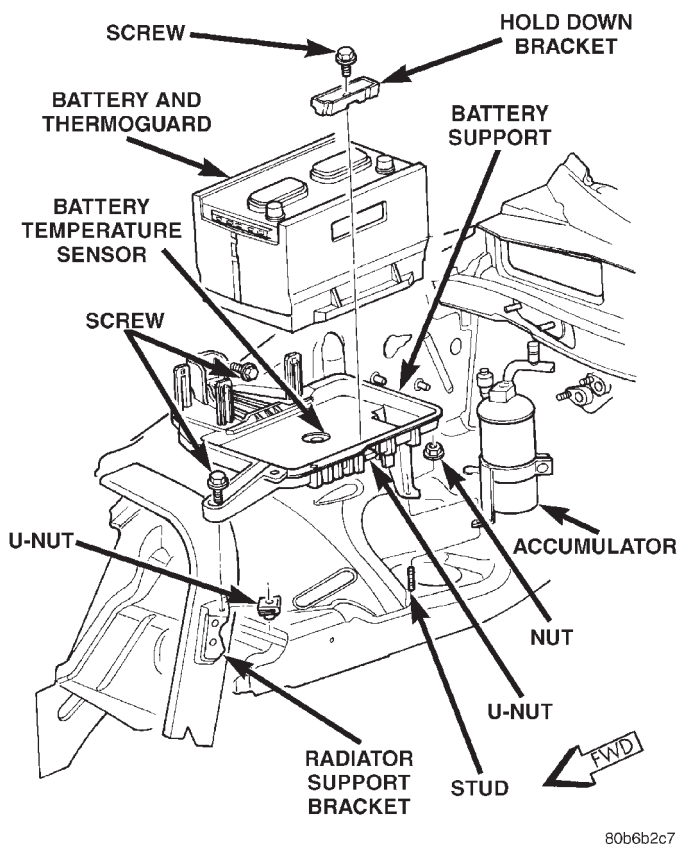
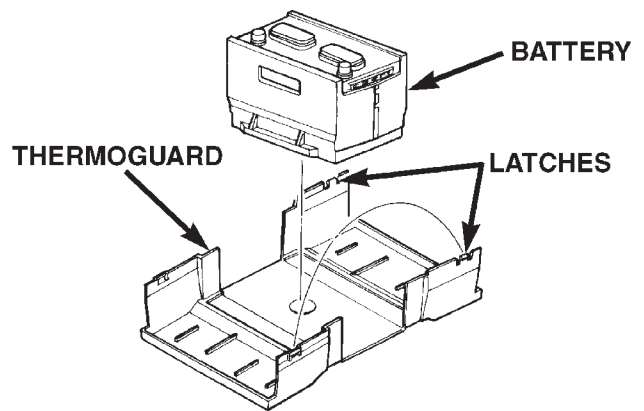

**Fig. 17 Battery Remove/Install**

(6) Inspect the battery support and the hold down bracket for damage. Clean the battery support and the hold down bracket with a sodium bicarbonate

(baking soda) and warm water cleaning solution to remove any acid film. Replace any damaged parts.

(7) Release the latch on each end of the battery thermoguard (Fig. 18) and remove the thermoguard from the battery.



80b6b2c8

**Fig. 18 Battery Thermoguard Remove/Install**

(8) Inspect the battery thermoguard for damage. Clean the thermoguard using a sodium bicarbonate (baking soda) and warm water cleaning solution to remove any acid film. Replace any damaged parts.

(9) Inspect the battery case for cracks or other damage that could result in electrolyte leaks. Also, check the battery terminal posts for looseness. Batteries with damaged cases or loose posts must be replaced.

(10) Check the electrolyte level in the battery. Use a putty knife or another suitable wide flat-bladed tool to pry the cell caps off (Fig. 19). Do not use a screwdriver. Add distilled water to each cell until the liquid reaches the bottom of the vent well. **DO NOT OVERFILL.**

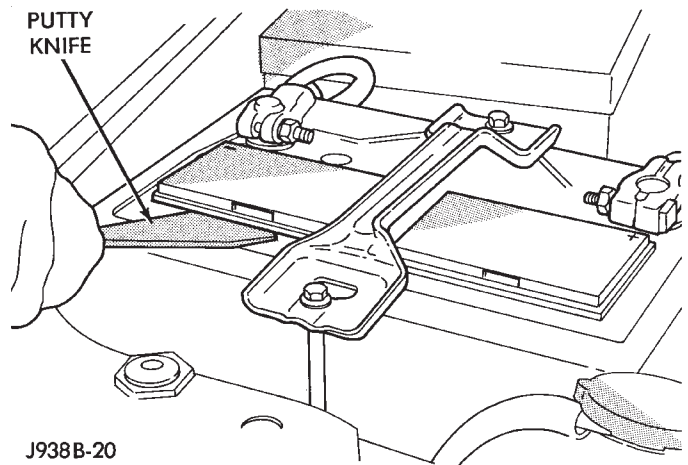
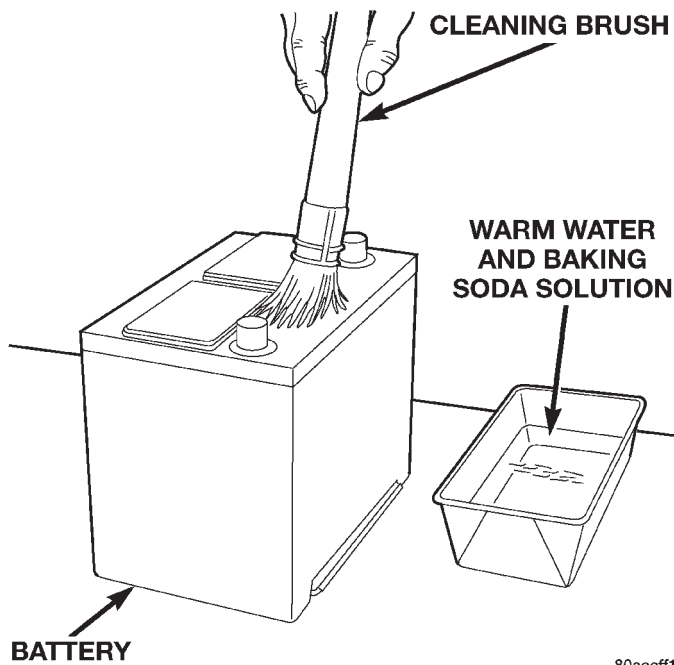

**Fig. 19 Removing Battery Cell Caps - Typical**

## REMOVAL AND INSTALLATION (Continued)

(11) Inspect the battery built-in test indicator sight glass for an indication of the battery condition. If the battery is discharged, charge as required. Refer to **Built-In Test Indicator** in the Diagnosis and Testing section of this group for more information. Also refer to **Battery Charging** in the Service Procedures section of this group for more information.

(12) If the battery is to be reinstalled, clean the outside of the battery case and the top cover with a sodium bicarbonate (baking soda) and warm water cleaning solution to remove any acid film (Fig. 20). Rinse the battery with clean water. Ensure that the cleaning solution does not enter the battery cells through the vent holes. If the battery is being replaced, refer to **Battery Ratings and Classifications** in the Specifications section of this group. Confirm that the replacement battery is the correct size and has the correct ratings for the vehicle.



80accff1

**Fig. 20 Clean Battery - Typical**

(13) Clean any corrosion from the battery terminal posts with a wire brush or a post and terminal cleaner, and a sodium bicarbonate (baking soda) and warm water cleaning solution (Fig. 21).

## INSTALLATION

(1) Install the thermoguard over the battery case. Be certain that the latch on each end of the thermoguard is fully engaged.

(2) Position the battery and thermoguard unit in the battery support. Ensure that the positive and negative terminal posts are correctly positioned. The cable terminal clamps must reach the correct battery terminal post without stretching the cables (Fig. 22) or (Fig. 23).

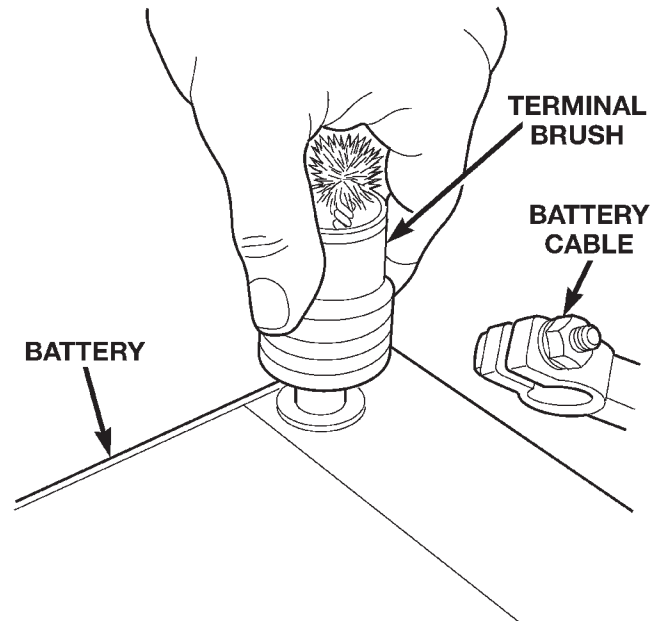

80accff2

**Fig. 21 Clean Battery Terminal Post - Typical**

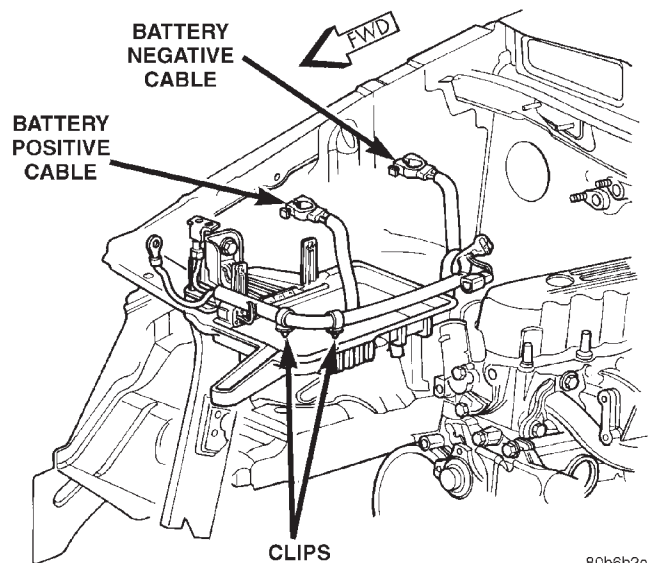

80b6b2c9

**Fig. 22 Battery Cables - 4.0L Engine**

(3) Be certain that the ledge on the outboard side of the battery case is engaged under the lip on the outboard side of the battery support, then loosely install the battery hold down bracket and screw. Be certain that the ledge on the bottom of the hold down bracket is oriented towards the inboard side of the battery case. Proper hold down bracket orientation can also be determined by noting the direction of the arrow-like formations of the molded reinforcing ribs on the top of the hold down bracket. These arrows should be pointed towards the battery.



REMOVAL AND INSTALLATION (Continued)

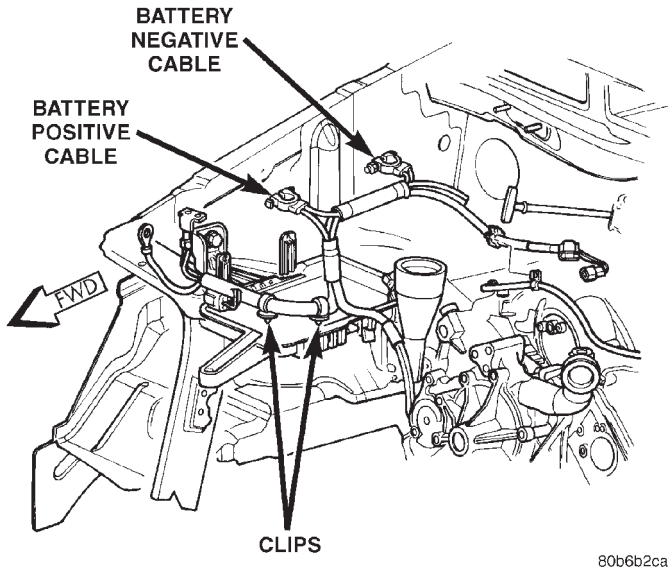

**Fig. 23 Battery Cables - 4.7L Engine**

(4) Once it is certain that the battery and the hold down bracket are properly positioned, tighten the

hold down bracket screw to 3.3 N·m (30 in. lbs.). Improper hold down fastener tightness, whether too loose or too tight, can result in damage to the battery, the hold down bracket, and/or the battery support.

**CAUTION:** Be certain that the battery cables are connected to the correct battery terminals. Reverse polarity may damage electrical components.

(5) Connect and tighten the battery positive cable terminal clamp. Then connect and tighten the battery negative cable terminal clamp. Tighten both battery cable terminal clamp nuts to 8.5 N·m (75 in. lbs.).

(6) Apply a thin coating of petroleum jelly or chassis grease to the exposed surfaces of the battery cable terminal clamps and battery terminal posts.

SPECIFICATIONS

BATTERY

Battery Classifications and Ratings					
Part Number	BCI Group Size Classification	Cold Cranking Amperage	Reserve Capacity	Ampere-Hours	Load Test Amperage
56041113	65	625	120 Minutes	69	300

