

BODY

CONTENTS

	page		page
BODY COMPONENTS	22	SEATS	14
PAINT	1	STATIONARY GLASS	4
POWER SUNROOF	7		

PAINT

INDEX

	page		page
DESCRIPTION AND OPERATION		WET SANDING, BUFFING, AND POLISHING	1
BASE COAT/CLEAR COAT FINISH	1	SPECIFICATIONS	
PAINT CODE	1	AFTER MARKET PAINT REPAIR PRODUCTS . . .	3
PAINTED SURFACE TOUCH-UP	1		

DESCRIPTION AND OPERATION

PAINT CODE

Exterior vehicle body colors are identified on the Body Code plate. The plate is located on the in the engine compartment and attached to the top of the right frame rail. Refer to the Introduction section at the front of this manual for body code plate description. The paint code is also identified on the Vehicle Safety Certification Label which is located on the drivers door shut face. The first digit of the paint code listed on the vehicle indicates the sequence of application, ie: P= primary coat, Q= secondary coat. The codes listed in the Aftermarket Paint Repair Products chart are used for manufacturing purposes. The first digit may vary from the Body Code Plate. The color names provided in the Aftermarket Paint Repair Products chart are the color names used on most repair product containers.

BASE COAT/CLEAR COAT FINISH

On most vehicles a two-part paint application (base coat/clear coat) is used. Color paint that is applied to primer is called base coat. The clear coat protects the base coat from ultraviolet light and provides a durable high-gloss finish.

CAUTION: Do not use abrasive chemicals or compounds on painted surfaces. Damage to finish can result.

Do not use harsh alkaline based cleaning solvents on painted surfaces. Damage to finish or color can result.

WET SANDING, BUFFING, AND POLISHING

Minor acid etching, orange peel, or smudging in clear coat or single-stage finishes can be reduced with light wet sanding, hand buffing, and polishing. **If the finish has been wet sanded in the past, it cannot be repeated. Wet sanding operation should be performed by a trained automotive paint technician.**

CAUTION: Do not remove clear coat finish, if equipped. Base coat paint must retain clear coat for durability.

PAINTED SURFACE TOUCH-UP

When a painted metal surface has been scratched or chipped, it should be touched-up as soon as possible to avoid corrosion. For best results, use Mopar® Scratch Filler/Primer, Touch-Up Paints and Clear Top Coat. Refer to Introduction group of this manual for Body Code Plate information.

DESCRIPTION AND OPERATION (Continued)

CAUTION: USE A OSHA APPROVED BREATHING FILTER WHEN SPRAYING PAINT OR SOLVENTS IN A CONFINED AREA. PERSONAL INJURY CAN RESULT.

TOUCH-UP PROCEDURE

(1) Scrape loose paint and corrosion from inside scratch or chip.

(2) Clean affected area with Mopar® Tar/Road Oil Remover, and allow to dry.

(3) Fill the inside of the scratch or chip with a coat of filler/primer. Do not overlap primer onto good surface finish. The applicator brush should be wet enough to puddle-fill the defect without running. Do not stroke brush applicator on body surface. Allow the filler/primer to dry hard.

(4) Cover the filler/primer with color touch-up paint. Do not overlap touch-up color onto the original color coat around the scratch or chip. Butt the new color to the original color, if possible. Do not stroke applicator brush on body surface. Allow touch-up paint to dry hard.

(5) On vehicles without clear coat, the touch-up color can be lightly wet sanded (1500 grit) and polished with rubbing compound.

(6) On vehicles with clear coat, apply clear top coat to touch-up paint with the same technique as described in Step 4. Allow clear top coat to dry hard. If desired, Step 5 can be performed on clear top coat.

CAUTION: AVOID PROLONGED SKIN CONTACT WITH PETROLEUM OR ALCOHOL – BASED CLEANING SOLVENTS. PERSONAL INJURY CAN RESULT.

SPECIFICATIONS

AFTER MARKET PAINT REPAIR PRODUCTS

EXTERIOR COLOR

EXTERIOR COLOR	CHRY CODE *	PPG	DuPONT	S-W** M-S**	AKZO NOBEL SIKKENS	ICI**
Sienna Tinted Pearl Coat	WUL	5477	F7938	56687/ 56688	CHA99:WUL	LFF5B
Sienna Pearl Coat	WUR	5510	N/A	56369	CHA99:WUR	LFF7B
Flame Red Clear Coat	PR4	4679	B9326	46916	CHA93:PR4	2NN6B
Deep Slate Pearl Coat	VAW	5292	B9774	54118	CHA97:VAW	HMRB
Champagne Pearl Meallic Clear Coat	VTE	5360	B9825	55700	CHA98:VTE	JAF2B
Champagne Pearl Coat	WTH	5475	B9882	57056	CHA99:WTH	LLY7B
Everglade Pearl Coat	WPT	5472	F8200	56686	CHA99:WPT	LEC8B
Deep Amethyst Pearl Coat	TCN	5246	B9736	52026	CHA97:TCN	FNE4B
Bright Metallic Clear Coat	MS4	4820	B9642	48823	CHA94:MS4	6GG7B
Black Clear Coat	DX8	9700	99	34858 90-5950	CHA85:DX8	TC60B
Taupe Frost Pearl Coat	TTK	5244	B9750	52567	CHA97:TTK	FNE5B
Stone White Clear Coat	SW1	83542	B9622	51540	CHA96:SW1	8KY5B
Bright White Clear Coat	GW7	4037	B8833	37298	CHA88:GW7	TA45B

INTERIOR COLOR

INTERIOR COLOR	CHRY CODE	PPG	DuPONT	S-W** M-S**	AKZO NOBEL SIKKENS	ICI**
Agate	AZ	9856/2-1461	C9208	45994	CHALAZI	7WCB
Camel	K5	27731/2-1584	C9603	51541	CHARK5I	7VX6
Taupe	L5	28653/2-1652	C9873	54420	CHARL5I	KXE6

NOTE: *Herberts Standox, Spies Hecker, and BASF use the Chrysler paint code as listed on the Body Code Plate and the Vehicle Safety Certification

label. ** S-W = Sherwin-Williams, M-S = Martin Senour, ICI = ICI Autocolor.

STATIONARY GLASS

INDEX

	page		page
DESCRIPTION AND OPERATION		WINDSHIELD	4
SAFETY PRECAUTIONS	4		
REMOVAL AND INSTALLATION			
QUARTER WINDOW GLASS	6		

DESCRIPTION AND OPERATION

SAFETY PRECAUTIONS

WARNING: DO NOT OPERATE THE VEHICLE WITHIN 24 HOURS OF WINDSHIELD INSTALLATION. IT TAKES AT LEAST 24 HOURS FOR URETHANE ADHESIVE TO CURE. IF IT IS NOT CURED, THE WINDSHIELD MAY NOT PERFORM PROPERLY IN AN ACCIDENT.

URETHANE ADHESIVES ARE APPLIED AS A SYSTEM. USE GLASS CLEANER, GLASS PREP SOLVENT, GLASS PRIMER, PVC (VINYL) PRIMER AND PINCH WELD (FENCE) PRIMER PROVIDED BY THE ADHESIVE MANUFACTURER. IF NOT, STRUCTURAL INTEGRITY COULD BE COMPROMISED.

CHRYSLER DOES NOT RECOMMEND GLASS ADHESIVE BY BRAND. TECHNICIANS SHOULD REVIEW PRODUCT LABELS AND TECHNICAL DATA SHEETS, AND USE ONLY ADHESIVES THAT THEIR MANUFACTURERS WARRANT WILL RESTORE A VEHICLE TO THE REQUIREMENTS OF FMVSS 212. TECHNICIANS SHOULD ALSO INSURE THAT PRIMERS AND CLEANERS ARE COMPATIBLE WITH THE PARTICULAR ADHESIVE USED.

BE SURE TO REFER TO THE URETHANE MANUFACTURER'S DIRECTIONS FOR CURING TIME SPECIFICATIONS, AND DO NOT USE ADHESIVE AFTER ITS EXPIRATION DATE.

VAPORS THAT ARE EMITTED FROM THE URETHANE ADHESIVE OR PRIMER COULD CAUSE PERSONAL INJURY. USE THEM IN A WELL-VENTILATED AREA.

SKIN CONTACT WITH URETHANE ADHESIVE SHOULD BE AVOIDED. PERSONAL INJURY MAY RESULT.

ALWAYS WEAR EYE AND HAND PROTECTION WHEN WORKING WITH GLASS.

CAUTION: Protect all painted and trimmed surfaces from coming in contact with urethane or primers.

Be careful not to damage painted surfaces when removing moldings or cutting urethane around windshield.

It is difficult to salvage a windshield during the removal operation. The windshield is part of the structural support for the roof. The urethane bonding used to secure the windshield to the fence is difficult to cut or clean from any surface. If the moldings are set in urethane, it would also be unlikely they could be salvaged. Before removing the windshield, check the availability of the windshield and moldings from the parts supplier.

REMOVAL AND INSTALLATION

WINDSHIELD

REMOVAL

- (1) Remove inside rear view mirror.
- (2) Remove cowl cover.
- (3) Remove screws attaching windshield side molding to A-pillar (Fig. 1).
- (4) Remove upper windshield molding.
- (5) Cut urethane bonding from around windshield using a suitable sharp cold knife. A pneumatic cutting device can be used if available (Fig. 2).
- (6) Separate windshield from vehicle.

INSTALLATION

WARNING: REVIEW ALL WARNINGS AND CAUTIONS IN THIS GROUP BEFORE PRECEDING WITH INSTALLATION.

CAUTION: Open a window before installing windshield. This will avoid pressurizing the passenger compartment. If a door or liftgate is slammed before urethane is cured, water leaks can result.

The windshield fence should be cleaned of old urethane bonding material. Support spacers should be

REMOVAL AND INSTALLATION (Continued)

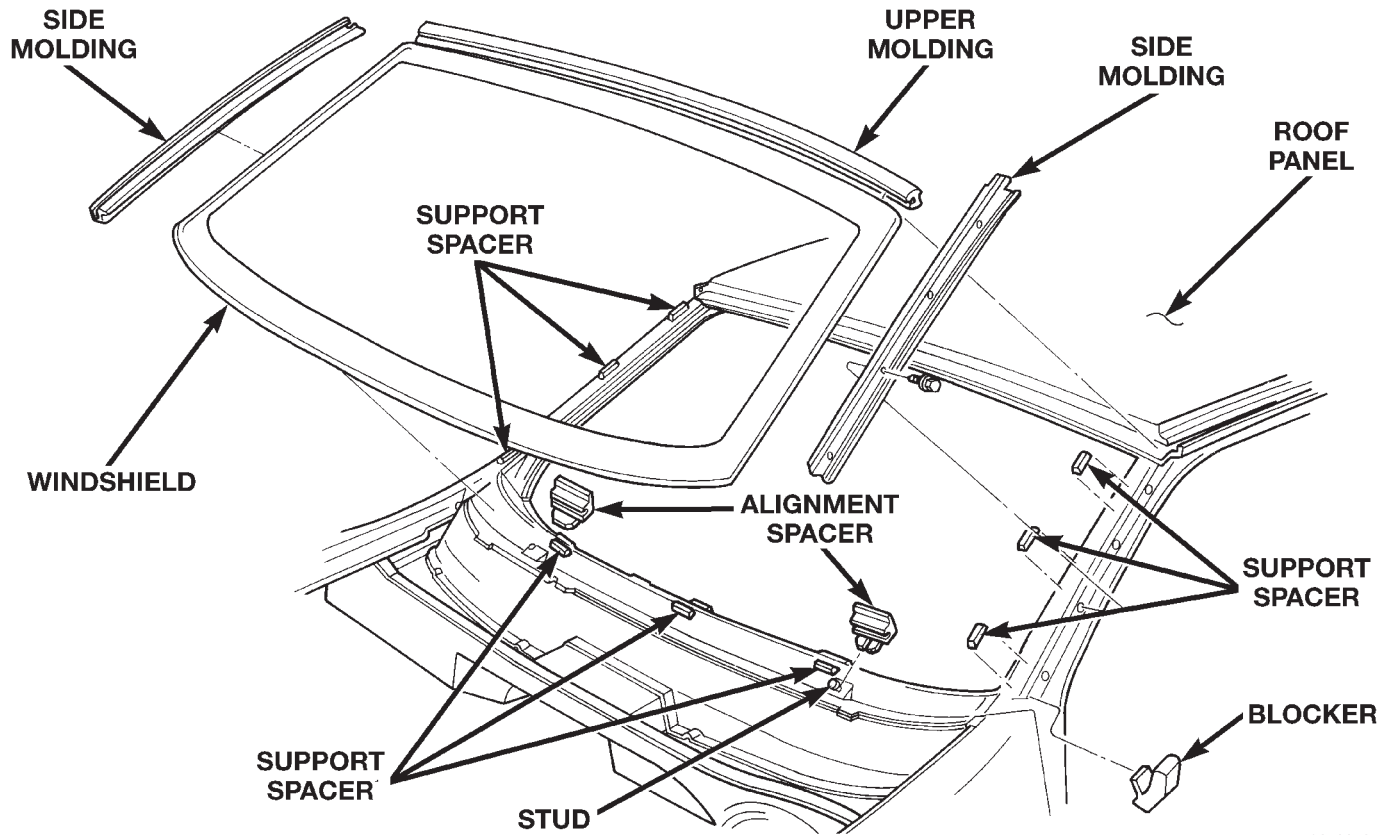

80500535

Fig. 1 Windshield

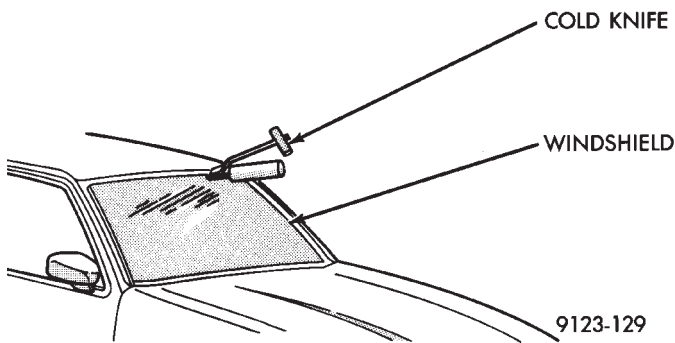

9123-129

Fig. 2 Cut Urethane Around Windshield—Typical

cleaned and properly installed on weld studs or repair screws at bottom of windshield opening.

(1) Place replacement windshield into windshield opening. Position glass in the center of the opening against the support spacers. Mark the glass at the support spacers with a grease pencil or masking tape and ink pen to use as a reference for installation. Remove replacement windshield from windshield opening (Fig. 3).

(2) Position the windshield inside up on a suitable work surface with two padded, wood 10 cm by 10 cm by 50 cm (4 in. by 4 in. by 20 in.) blocks, placed parallel 75 cm (2.5 ft.) apart (Fig. 4).

(3) Clean inside of windshield with Mopar Glass Cleaner and lint-free cloth.

(4) Apply clear glass primer 25 mm (1 in.) wide around edge of windshield. Wipe with clean/dry lint-free cloth.

(5) Apply black-out primer 15 mm (.75 in.) wide on top and sides of windshield and 25 mm (1 in.) on bottom of windshield. Allow at least three minutes drying time.

(6) Position windshield spacers on lower fence above support spacers at the edge of the windshield opening (Fig. 1).

(7) Apply a 10 mm (0.4 in.) bead of urethane around perimeter of windshield along the inside of the moldings. Apply two beads along the bottom edge.

(8) Install upper molding onto windshield.

(9) Apply fence primer around the perimeter of the windshield opening fence. Allow at least 18 minutes drying time.

(10) With aid of a helper, position windshield over windshield opening. Align reference marks at bottom of windshield to support spacers.

(11) Slowly lower windshield glass to windshield opening fence. Guide top molding into proper position if necessary. Push windshield inward to fence spacers at bottom and until top molding is flush to roof line.

REMOVAL AND INSTALLATION (Continued)

- (12) Clean excess urethane from exterior with Mopar Super Clean or equivalent.
- (13) Install windshield side moldings.
- (14) Install cowl cover and wipers.
- (15) Install inside rear view mirror.
- (16) After urethane has cured, water test windshield to verify repair.

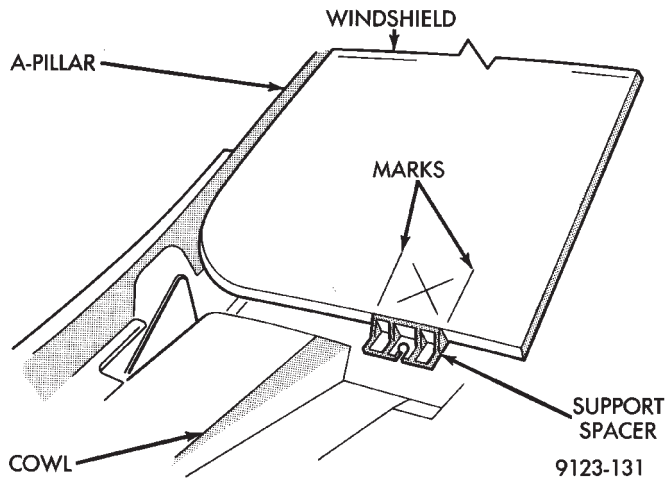

Fig. 3 Center Windshield and Mark at Support Spacers

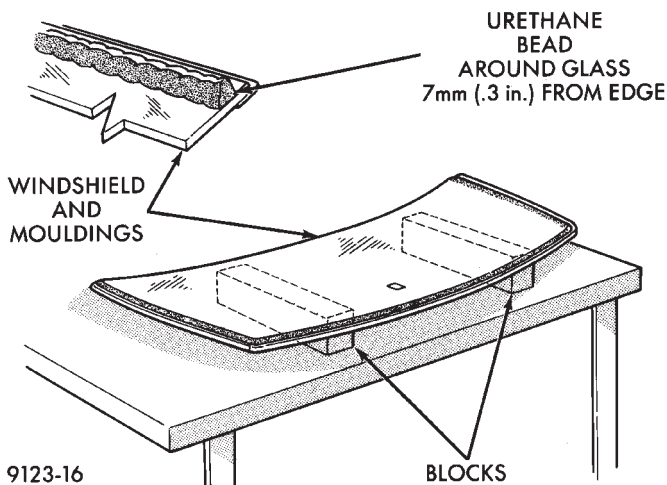

Fig. 4 Work Surface Set up and Molding Installation

QUARTER WINDOW GLASS

REMOVAL

- (1) Cut urethane bonding from around quarter window glass using a suitable sharp cold knife. A pneumatic cutting device can be used if available.

- (2) Separate glass from vehicle.

INSTALLATION

CAUTION: Open a window before installing glass. This will avoid pressurizing the passenger compartment. If a door or liftgate is slammed before urethane is cured, water leaks can result.

The window opening fence should be cleaned of old urethane bonding material.

- (1) Clean inside of glass with Mopar Glass Cleaner and lint-free cloth.

- (2) Apply PVC (vinyl) primer 25 mm (1 in.) wide around edge of glass. Wipe with clean/dry lint-free cloth.

- (3) Apply fence primer around edge of fence. Allow at least eighteen minutes drying time.

- (4) Apply a 10 mm (0.4 in.) bead of urethane around window vinyl border location.

Position glass into window opening and lock clips into place (Fig. 5).

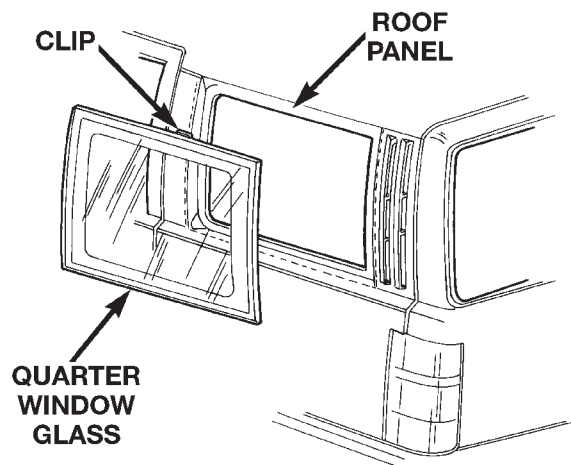

804d8ede

Fig. 5 Quarter Window Glass

POWER SUNROOF

INDEX

	page		page
DESCRIPTION AND OPERATION		SUNROOF GLASS PANEL	10
SUNROOF OPERATION	7	SUNROOF GLASS PANEL TIMING	12
SERVICE PROCEDURES		SUNROOF HOUSING ASSEMBLY	13
DIAGNOSTIC PROCEDURES	7	SUNROOF SUNSHADE	12
REMOVAL AND INSTALLATION		SUNROOF WIND DEFLECTOR	10
DRAIN TUBE	10	ADJUSTMENTS	
SUNROOF DRIVE MOTOR	11	SUNROOF GLASS PANEL ADJUSTMENT	13
SUNROOF EXPRESS MODULE	11		

DESCRIPTION AND OPERATION

SUNROOF OPERATION

WARNING: Keep fingers and other body parts out of sunroof opening at all times.

The sunroof features a power sliding glass panel and a sunshade which can be manually positioned anywhere along its travel, rearward of glass panel front edge.

The sunroof is electrically operated from a switch located on the mini overhead console. To operate the sunroof the ignition switch must be in the On/Run position. The sunroof has both manual and Express Open modes of operation when opening. To open the sunroof in the Express Open mode, the switch is pressed rearward for less than **1 second**. This causes the sunroof glass to automatically retract and stop at the "Comfort Stop" position, a position approximately four inches forward of full open that reduces low speed wind buffeting. If desired, the sunroof glass can then be fully opened in Express Open mode by again pressing the switch rearward for less than **1 second**. The sunroof can also be opened manually by pressing and holding the switch rearward. Once the switch is held rearward for more than **1 second**, the glass will retract in the manual mode. Releasing the switch at any time during travel will cause the sunroof to stop at the current position.

To close the sunroof from an open position, the switch must be pushed forward and held until the sunroof reaches the fully closed position. Releasing the switch at any time in this mode will cause the sunroof to stop at the current position.

To vent the sunroof from the closed position, the switch is pushed forward and held. Releasing the switch at any time during travel will cause the sunroof to stop at the current vent position. To reach the fully vented position, continue to hold the switch forward until vent

motion stops. To close the sunroof from the vent position, push and hold the switch rearward until the glass reaches the fully closed position.

SERVICE PROCEDURES

DIAGNOSTIC PROCEDURES

Before beginning sunroof diagnostics verify that all other power accessories are in proper operating condition. Refer to Sunroof Diagnostic Chart for possible causes. If not, a common electrical problem may exist. Refer to Group 8W, Wiring Diagrams, of this publication for circuit, splice and component descriptions. Check the condition of the circuit protection (20 amp high current fuse (battery feed) located in the Power Distribution Center (PDC). Check the cover of the PDC for location of the fuse. The ten amp fuse (ignition feed) located in cavity 14 of the Junction Block). Inspect all wiring connector pins for proper engagement and continuity. Check for battery voltage at battery and ignition pins of the power sunroof express module wiring connector. Refer to Group 8W, Wiring Diagrams, for circuit information. The controller will not operate at less than 10 volts. Check the ground at the sunroof express module.

Before beginning diagnosis for wind noise or water leaks, verify that the problem was not caused by releasing the control switch before the sunroof was fully closed. The sunroof module has a water-management system. During washing high-pressure water may be forced between the glass panel seal and the roof opening. Normally this water will drain. However, when some type of drying blower system is used, like those found in automatic car washes, the water may not have a chance to drain before the blower forces air between the seal and the roof opening. This causes the water to blow over the edge of the module and onto the headlining.

Refer to (Fig. 1) Sunroof Assembly for exploded view of the sunroof.

SERVICE PROCEDURES (Continued)

SUNROOF DIAGNOSIS CHART

SYMPTOM	POSSIBLE CAUSE
Sunroof motor inoperative.	Faulty control switch. Faulty circuit ground between sunroof express module, drive motor, control switch, and body harness. Faulty power circuit between sunroof express module, drive motor, switch, and body harness. Faulty sunroof drive motor. Faulty sunroof express module. Faulty sunroof drive motor connector.
Audible whine when switch is depressed, sunroof does not operate.	Faulty sunroof drive motor. Binding cable.
Audible clicking or ratcheting when switch is pressed, sunroof does not operate.	Broken or worn drive cable. Worn drive motor gear. Mechanisms not synchronized.
Sunroof vents and opens, but does not close.	Binding cable. Faulty circuit. Faulty control switch. Faulty sunroof express module. Faulty drive motor.
Sunroof vents, but does not open.	Binding linkage. Faulty circuit. Faulty switch. Faulty sunroof controller. Faulty drive motor.
Sunroof does not vent	Binding cable. Faulty circuit. Faulty control switch. Faulty sunroof express module.
Sunroof water leak.	Drain tubes cut, disconnected, clogged or kinked. Drain tube grommet loose at floorpan. Glass panel improperly adjusted. Faulty glass panel seal.
Wind noise from sunroof.	Front of glass panel too high or rear too low. Glass panel not centered in opening. Faulty glass panel seal. Roof rack crossbar too close to rear of sunroof opening.
Rattles from open sunroof while driving	Loose or broken attaching hardware. Worn or broken mechanism.
Rattles from closed sunroof while driving	Loose or broken attaching hardware. Worn or broken mechanism. Loose wiring or wiring components.

SERVICE PROCEDURES (Continued)

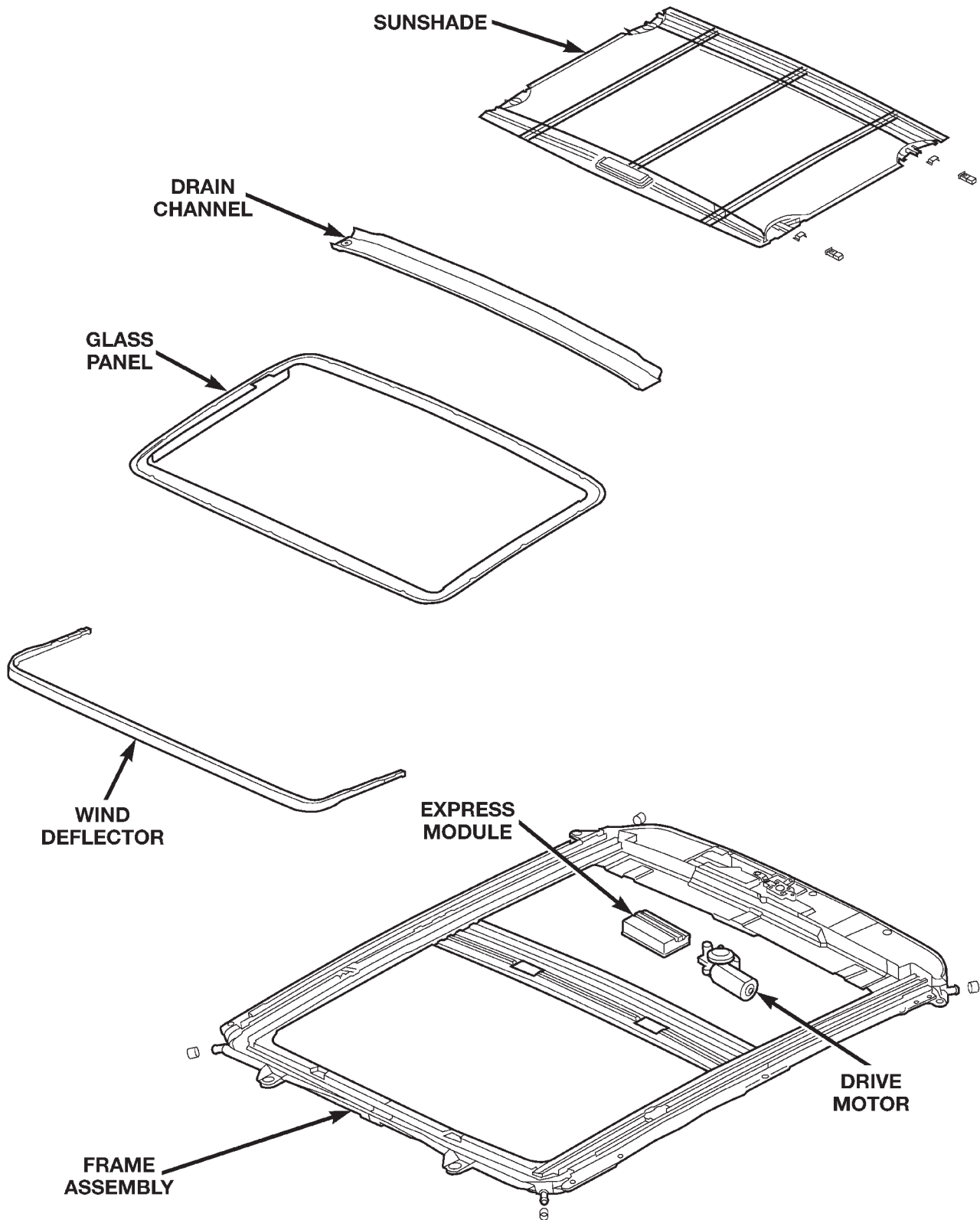

Fig. 1 Sunroof Assembly

REMOVAL AND INSTALLATION

SUNROOF WIND DEFLECTOR

REMOVAL

- (1) Open sunroof glass panel.
- (2) Push down one corner of the wind deflector and let the other corner rise up (Fig. 2).
- (3) Push the low corner towards the opposite side of the vehicle until tab on sunshade clears the body. Then raise the corner up.
- (4) Repeat the procedure to the other corner.
- (5) Lift wind deflector to 90% of the way.
- (6) Push the attaching ends of the deflector to the rear of the vehicle to disengage the deflector.

INSTALLATION

- (1) Place wind deflector at 90% in the vertical position to the sunroof. With the sunroof open.
- (2) Push ends of the deflector towards the front of the vehicle to engage ends.
- (3) Lower wind deflector to normal position.
- (4) Push one corner to the opposite side of the vehicle until tab clears vehicle body and lower deflector for that corner.
- (5) Push the side that was just installed completely down.
- (6) Push the opposite corner cross vehicle until tab clears the body. Then lower deflector to position.
- (7) Test sunroof operation.

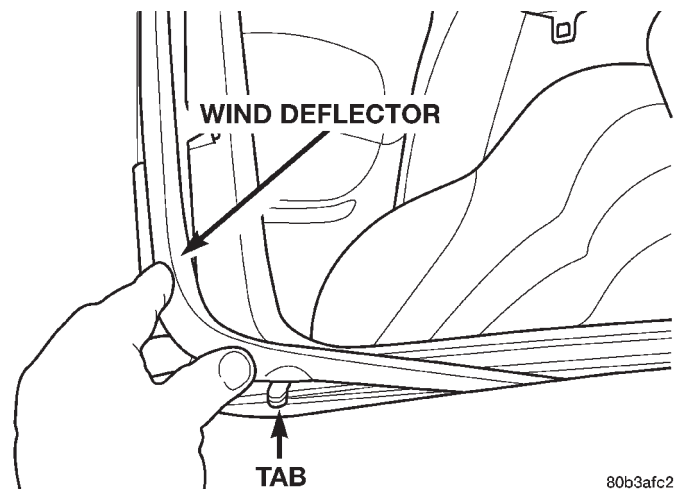

Fig. 2 Wind Deflector

SUNROOF GLASS PANEL

REMOVAL

- (1) Slide sunshade rearward to the open position.
- (2) Move the glass panel to the fully closed position.
- (3) Remove the four attaching screws (Fig. 3).
- (4) Lift off glass panel and remove from vehicle.

INSTALLATION

NOTE: Sunroof glass must be set in place and attached as close as possible to flush with the roof surface. For wind noise reasons, care must be taken to ensure that the glass is not remounted either a) Overflush to the roof surface at the front edge of the glass, or b) Underflush to the roof surface at the rear edge of the glass.

- (1) Position glass panel in to opening.
- (2) Start the four attaching screws.
- (3) Tighten screws.
- (4) Verify sunroof operation and alignment. Check fit and adjust as necessary, refer to Sunroof Glass Panel Adjustment for proper procedures.

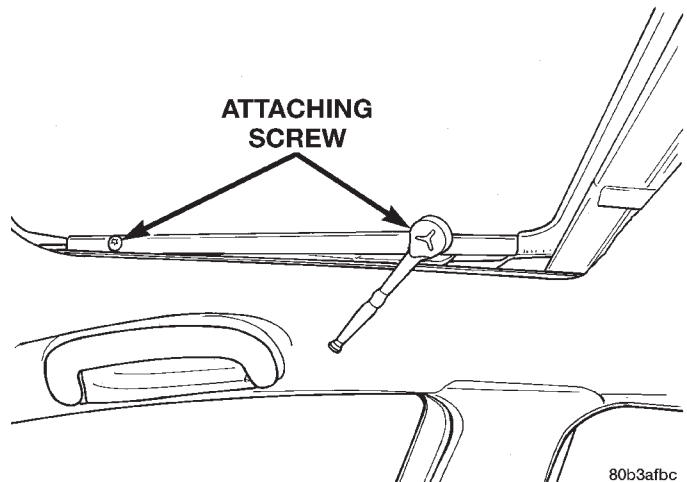

Fig. 3 Sunroof Glass Panel Removal

DRAIN TUBE

REMOVAL

- (1) Remove the headliner to access clamps attaching drain tube to sunroof (Fig. 4).
- (2) Disengage clamps attaching drain tube to sunroof .
- (3) Tape the end of the old drain tube to the new drain tube. Ensure that the tape build up on the tube ends is not excessive.
- (4) Remove front/rear trim panels as necessary to disengage clamps securing drain tube to body .
- (5) Remove the drain tube plug from the underside of the vehicle.
- (6) From the underside of the vehicle carefully, pull/route the drain tube through the body panel. Applying a soapy water solution to the new tube may aid in this procedure.

INSTALLATION

- (1) Install the plug adapter to the bottom of the drain tube.

REMOVAL AND INSTALLATION (Continued)

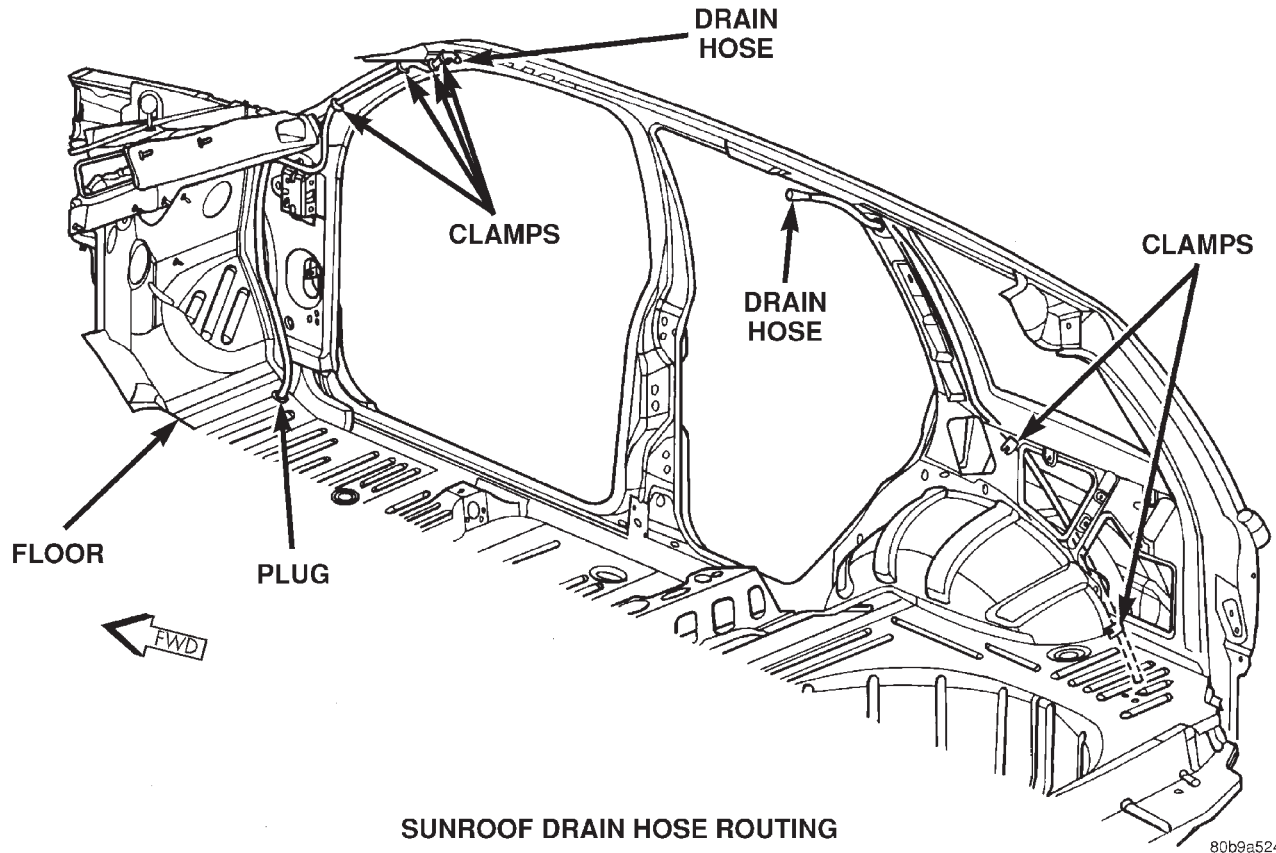

SUNROOF DRAIN HOSE ROUTING

80b9a524

Fig. 4 Sunroof Drain Hose Routing

- (2) Engage clamps securing drain tube to body (Fig. 4).
- (3) Install front/rear trim panels as necessary.
- (4) Install drain tube to sunroof and engage clamp.
- (5) Install the headliner.
- (3) Connect the wire connectors to the sunroof express module.
- (4) Install the headliner into position.
- (5) Install the A-pillar trim, sun visors, and map lamp/mini console.
- (6) Test sunroof operation, adjust if necessary.

SUNROOF EXPRESS MODULE**REMOVAL**

- (1) Move the glass panel to the fully closed position.
- (2) Remove A-pillar trim, sun visors, and map lamp/mini console.
- (3) Lower headliner as necessary to gain access to the sunroof express module.
- (4) Disconnect the express module wire harness connectors.
- (5) Remove express module screw.
- (6) Remove express module from the keyway by sliding module towards the center of the vehicle.

INSTALLATION

- (1) Insert sunroof express module in the keyway located in the sunroof module and slide the module outward to lock it into position.
- (2) Install the sunroof express module screw.

SUNROOF DRIVE MOTOR**REMOVAL**

NOTE: The sunroof system is timed from the factory so that the motor shuts off automatically when the sunroof window reaches a certain position. Extreme care must be taken when removing the motor, timing may be thrown off causing possible damage to the sunroof system. Anytime the motor is removed from the sunroof assembly the sunroof glass panel must be in the **FULLY CLOSED POSITION** or the unit will be out of timing. The drive motor cannot be reset to the park position after being removed.

- (1) Move glass panel to the fully closed position.
- (2) Remove A,B,C, and D-pillar trim, sun visors, and map lamps/mini console.
- (3) Disconnect the control switch wire connector.

REMOVAL AND INSTALLATION (Continued)

(4) Remove headliner as necessary to gain access to sunroof drive motor. Refer to Headliner Removal and Installation for proper procedures.

(5) Disconnect the drive motor wire harness connectors (Fig. 5).

(6) Remove drive motor fasteners and remove motor from the sunroof housing .

INSTALLATION

(1) Ensure that the window is in the fully closed position before mounting the motor. If motor fails with the window in the open position the sunroof glass panel timing will have to be timed. The new motor comes in the fully closed position and with a gage for setting cable timing. Refer to Sunroof Glass Panel Timing.

(2) Place drive motor into position on the sunroof housing and install fasteners.

(3) Connect express module, drive motor, and control switch wire connectors.

(4) Set headliner into position.

(5) Test sunroof operation, adjust as necessary.

(6) Finish installing the headliner.

(7) Connect the control switch wire connector.

(8) Install A,B, C, and D-pillar trim, sun visors, and map lamps/mini console.

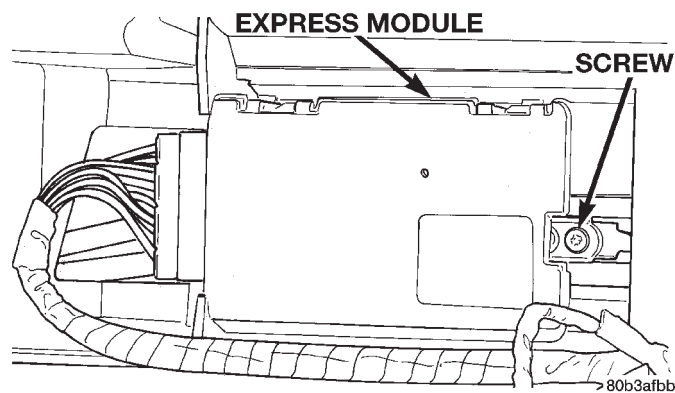

Fig. 5 Sunroof Drive Motor and Express Module

SUNROOF GLASS PANEL TIMING

Sunroof Drive Cable Timing

NOTE: A gage comes with the new motor.

(1) If the glass panel was not in the fully closed position, when the motor was removed, the sunroof glass panel needs to be timed, before the new motor is installed.

(2) Remove sunroof glass panel.

(3) Set gage into the track near the rear of the opening between the driver slide and the bracket (Fig. 6).

(4) Move the driver slide forward or aft to get proper setting.

(5) Repeat the operation on the other side.

(6) Install drive motor.

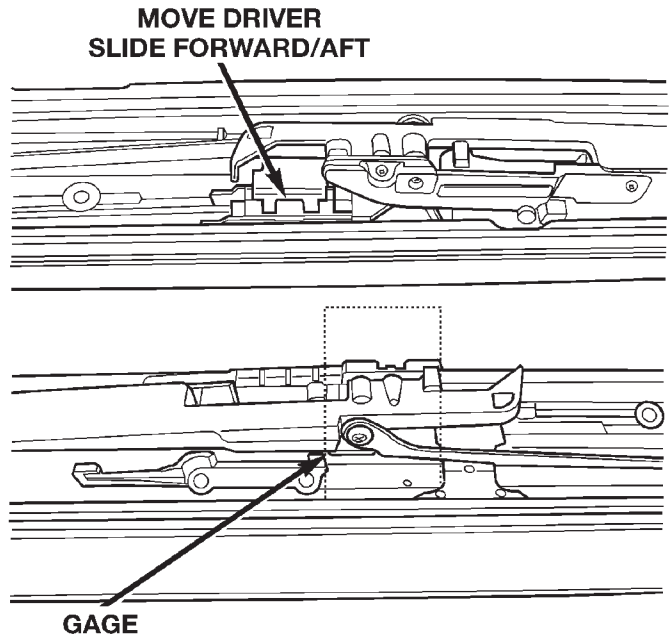

Fig. 6 Sunroof Drive Cable Timing

SUNROOF SUNSHADE

REMOVAL

- (1) Open sunroof approximately 50% of the way.
- (2) Push sunshade down until tabs clear glass.
- (3) Move sunshade forward of glass panel.
- (4) Compress the spring loaded plungers holding the guide blocks in the track.
- (5) Slide the sunshade forward while lifting the front through the opening until the rear guide blocks are accessible.

CAUTION: Use care not to crease the sunshade when removing or installing.

- (6) Disengage rear guide blocks from track.

INSTALLATION

(1) Install the sunshade from outside of the vehicle with the sunroof fully open.

(2) Put rear guide blocks into sunshade guide track .

(3) Push sunshade back and down through the sunroof opening.

(4) Using a flat blade tool, put front guide blocks into the sunshade track. By pushing the block towards the center of the vehicle.

(5) Move the glass panel to approximately halfway to the fully closed position.

REMOVAL AND INSTALLATION (Continued)

(6) Push sunshade down until the sunshade clears the glass then move sunshade rearward behind the glass panel.

SUNROOF HOUSING ASSEMBLY

REMOVAL

- (1) Move glass panel to the fully closed position.
- (2) Disconnect battery negative cable.
- (3) Recline both front seats.
- (4) Remove overhead console.
- (5) Remove headliner
- (6) Disconnect the drain tubes from sunroof housing (Fig. 7).
- (7) Loosen fasteners attaching sunroof housing assembly.
- (8) With the aid of a helper, remove fasteners attaching sunroof housing assembly to roof panel.

INSTALLATION

- (1) Raise the sunroof housing assembly and guide into position and start fasteners (Fig. 7).
- (2) Tighten the fasteners, front to rear, attaching the sunroof module to roof panel. Tighten the fasteners, front to rear, to 11 N·m (97 in. lbs.) torque.
- (3) Connect the drain tubes to the sunroof housing.
- (4) Set headliner into position.
- (5) Connect express module, drive motor, and control switch wire connectors.
- (6) Test sunroof operation, adjust as necessary.
- (7) Finish installing the headliner.
- (8) Connect battery negative cable.

ADJUSTMENTS

SUNROOF GLASS PANEL ADJUSTMENT

- (1) Move the sunshade rearward to the open position.
- (2) Move the sunroof glass panel to the fully closed position.

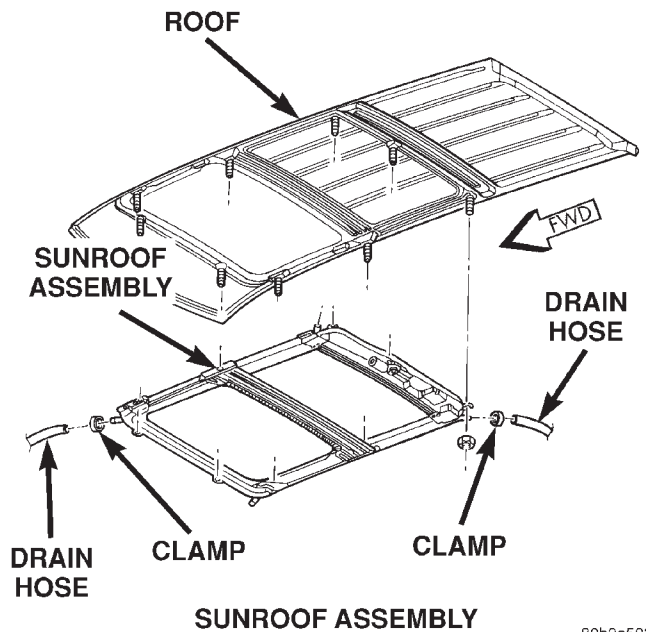

Fig. 7

- (3) Loosen the forward screws on each side enough to make the front adjustment.
- (4) Adjust the front of the sunroof glass panel 1 mm (1/32 inch) below the top surface of the roof panel.
- (5) Tighten the front two screws.
- (6) Loosen the rear screws on each side enough to make the rear adjustment.
- (7) Adjust the rear of the sunroof glass panel 1 mm (1/32 inch) above the top surface of the roof panel.
- (8) Tighten the rear two screws.
- (9) Check for proper fit. If not OK, repeat glass panel adjustment.

SEATS

INDEX

	page		page
REMOVAL AND INSTALLATION			
BUCKET SEAT BACK	16	REAR SEAT BACK LATCH/HINGE	19
BUCKET SEAT BACK COVER	17	REAR SEAT CUSHION	18
BUCKET SEAT CUSHION COVER	17	REAR SEAT CUSHION COVER	18
BUCKET SEAT HEAD RESTRAINT	16	REAR SEAT CUSHION RELEASE LATCH	18
BUCKET SEAT HEAD RESTRAINT SLEEVE	16	REAR SEAT FOLDING HEAD REST RELEASE KNOB	20
BUCKET SEAT RECLINER	15	REAR SEAT HEAD REST	20
BUCKET SEAT SIDE SHIELD	14	REAR SEAT HEAD REST FOLDING MECHANISM	21
BUCKET SEAT TRACK ADJUSTER	15	REAR SEAT HEAD REST SLEEVE	20
FRONT BUCKET SEAT	14	REAR SEATBACK	19
REAR SEAT BACK COVER	20		
REAR SEAT BACK LATCH RELEASE HANDLE	18		

REMOVAL AND INSTALLATION

FRONT BUCKET SEAT

REMOVAL

- (1) Move seat to full rearward position.
- (2) Remove front bolts attaching seat to floor pan (Fig. 1).
- (3) Move seat to full forward position.
- (4) Using a trim stick, pry cover from seat track (power seat only).
- (5) Remove rear bolts attaching seat to floor pan.
- (6) If equipped, disconnect power seat wire harness connector or belt buckle chime switch.
- (7) Remove seat from vehicle.

INSTALLATION

- (1) Position seat on floor pan.
- (2) If equipped, connect power seat wire harness connector or belt buckle chime switch.
- (3) Install rear bolts attaching seat to floor pan. Tighten bolts to 40 N·m (30 ft. lbs.) torque.
- (4) If equipped, install cover on seat track.
- (5) Move seat to full rearward position.
- (6) Install front bolts attaching seat to floor pan. Tighten bolts to 40 N·m (30 ft. lbs.) torque.

BUCKET SEAT SIDE SHIELD

REMOVAL

- (1) Remove screws attaching side shield to seat frame.
- (2) Disconnect wire harness connectors from power seat and power lumbar switches, if equipped.

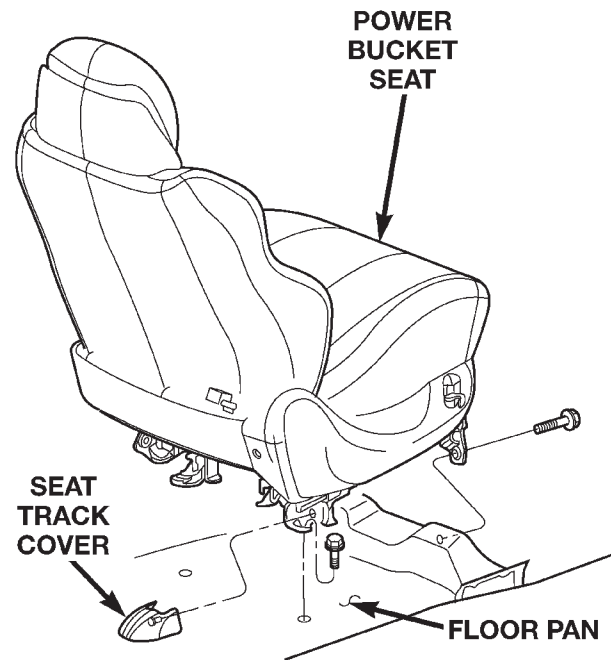

80b5cb24

Fig. 1 Front Bucket Seat

- (3) Separate side shield from seat.

INSTALLATION

- (1) Position side shield on seat.
- (2) Connect wire harness connectors to power seat and power lumbar switches, if equipped.
- (3) Install screws attaching side shield to seat frame.

REMOVAL AND INSTALLATION (Continued)

BUCKET SEAT TRACK ADJUSTER

REMOVAL

- (1) Remove seat.
- (2) Remove nuts attaching seat track adjuster to seat cushion frame (Fig. 2) and (Fig. 3).
- (3) Disengage clips attaching wire harness to adjuster.
- (4) Disengage seat memory module connector, if equipped.
- (5) Separate seat track from seat cushion frame.

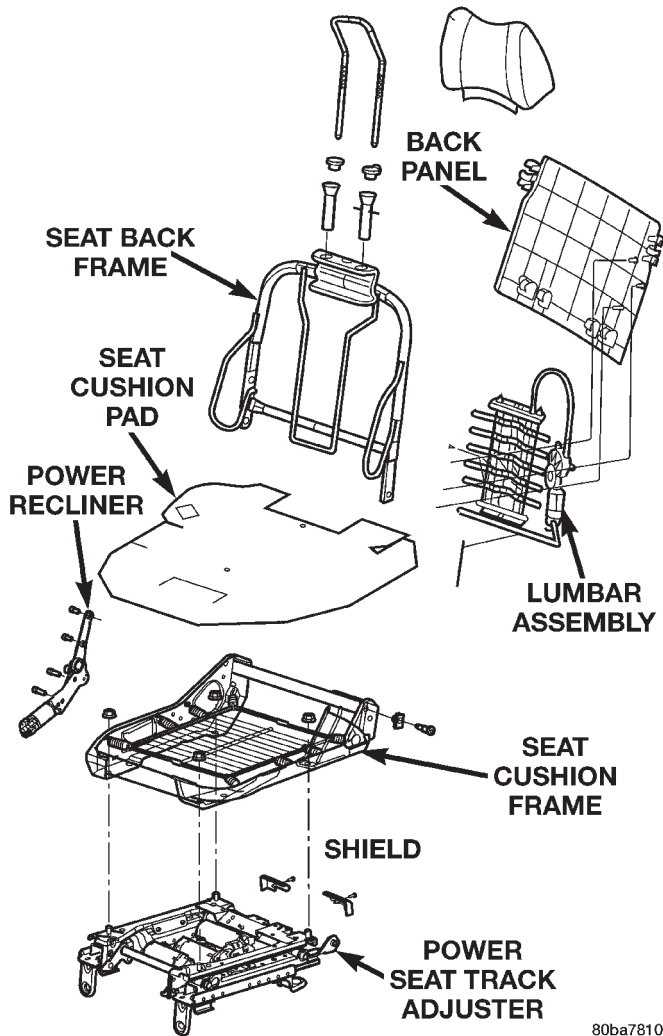
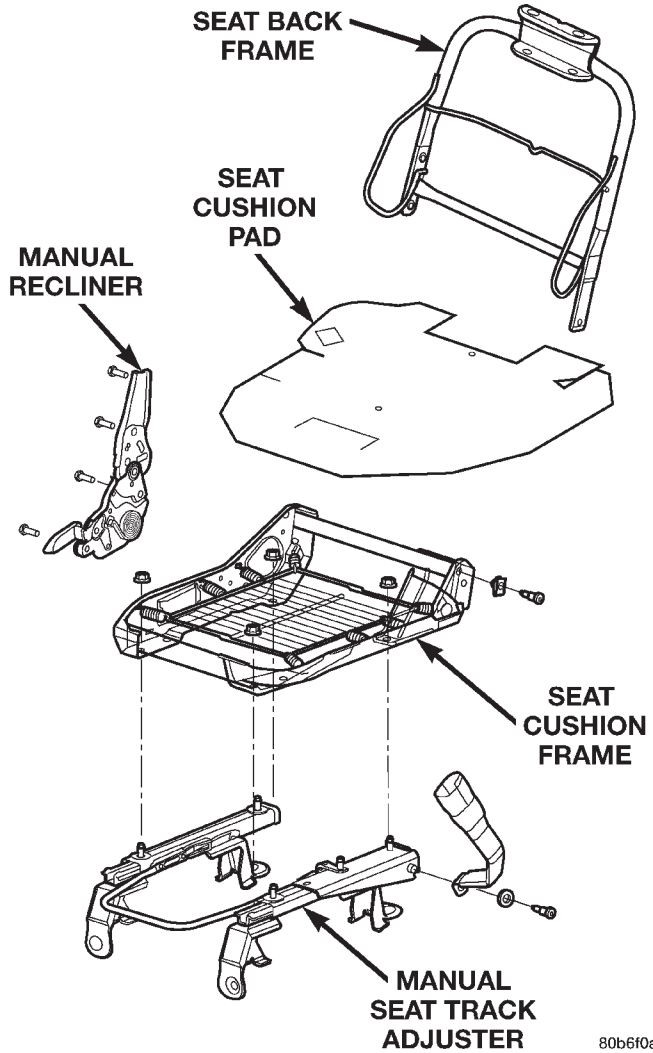

Fig. 2 Seat Track Adjuster—Power

80ba7810

INSTALLATION

- (1) Transfer seat memory module, if equipped.
- (2) Position seat track on seat cushion frame.
- (3) Route harness through frame and engage clips attaching wire harness to adjuster.
- (4) Engage seat memory module connector, if equipped.
- (5) Install nuts attaching seat track adjuster to seat cushion frame. Tighten nuts to 28 N-m (20 ft. lbs.) torque.



80b6f0aa

Fig. 3 Seat Track Adjuster — Manual

- (6) Install seat.

BUCKET SEAT RECLINER

REMOVAL

- (1) Remove seat back.
- (2) Disengage J-strap at base of seat back.
- (3) Roll seat back cover upward to access bolts attaching recliner to seat back frame.
- (4) Remove bolts attaching recliner to seat back frame.
- (5) Separate recliner from seat back.

INSTALLATION

- (1) Position recliner on seat back.
- (2) Install bolts attaching recliner to seat back frame. Tighten bolts to 28 N-m (20 ft. lbs.) torque.
- (3) Roll seat back cover downward.
- (4) Engage J-strap at base of seat back.
- (5) Install seat back.

REMOVAL AND INSTALLATION (Continued)

BUCKET SEAT BACK

REMOVAL

- (1) Move seat to full rearward position.
- (2) Remove inboard bolt attaching seat back frame to seat cushion frame.
- (3) Move seat to full forward position.
- (4) Move seat back to full recline position.
- (5) Remove screws attaching seat side shield to seat frame.
- (6) Disconnect wire harness connector from recliner motor, if equipped.
- (7) From the underside of the seat, disconnect the wire harness connector for the power lumbar and/or heated seat, if equipped.
- (8) Remove outboard bolts attaching recliner to seat cushion frame.
- (9) Route the power lumbar and/or heated seat harness through the seat cushion cover, if equipped.
- (10) Separate seat back from seat cushion.

INSTALLATION

- (1) Position seat back on seat cushion.
- (2) Route the power lumbar and heater harness through the seat cushion cover, if equipped.
- (3) Install recliner bolts attaching seat back frame to seat cushion frame. Tighten bolts to 28 N·m (20 ft. lbs.) torque.
- (4) Install the inboard bolt attaching seat back frame to seat cushion frame. Tighten bolt to 47N·m (35 ft.lbs.).
- (5) Connect wire harness connector to recliner motor and/or heated seat, if equipped.
- (6) From the underside of the seat, connect the power lumbar and/or heated seat wire harness connector to the seat harness, if equipped.
- (7) Install screws attaching seat side shield to seat frame.

BUCKET SEAT HEAD RESTRAINT

REMOVAL

- (1) Depress head restraint release button and lift head restraint to full up position.
- (2) Using a small flat blade, depress tab on right side head restraint release button and using your hand, simultaneously press tab on left side head restraint release button (Fig. 4) and pull head restraint up to separate from seat back.

INSTALLATION

- (1) Position head restraint in seat back, press tab on left side head restraint release button and push down to secure.

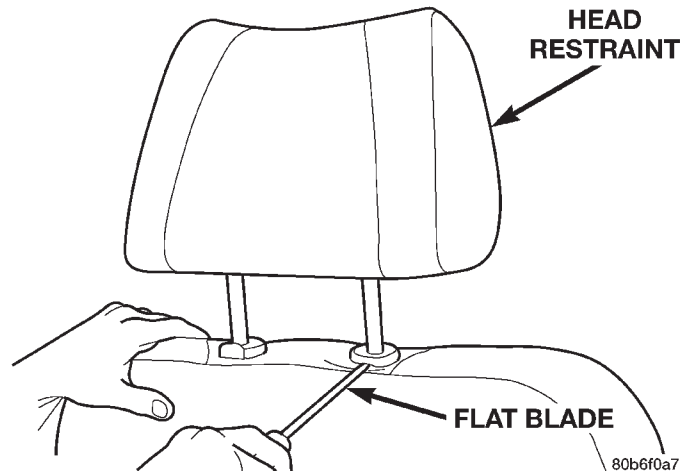

Fig. 4 Head Restraint

BUCKET SEAT HEAD RESTRAINT SLEEVE

REMOVAL

- (1) Remove head restraint.
- (2) Remove seat back.
- (3) Remove seat back cover.
- (4) Remove hog rings attaching cushion pad to seat back frame (Fig. 5).
- (5) Remove cushion pad from seat back frame.
- (6) Rotate head restraint sleeve 1/4 turn counter-clockwise to release retaining tab.
- (7) Pull sleeve from seat back frame (Fig. 6).

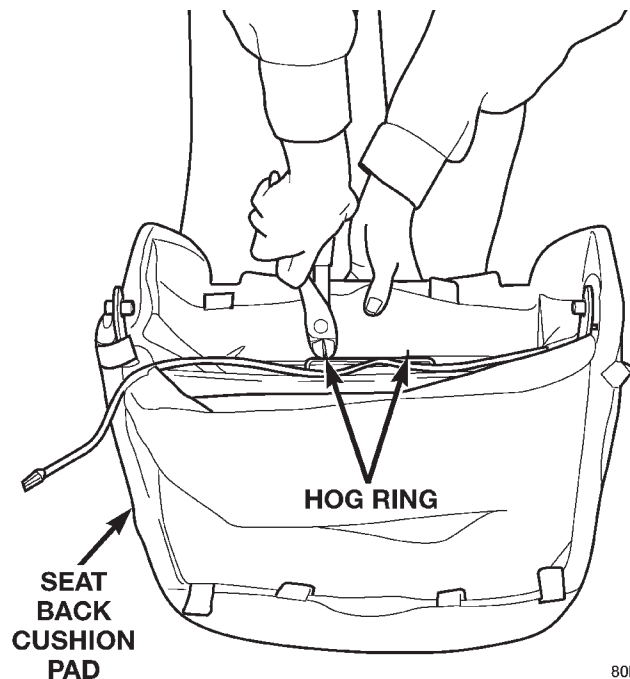

Fig. 5 Cushion Pad

INSTALLATION

- (1) Position sleeve in seat back frame.

REMOVAL AND INSTALLATION (Continued)

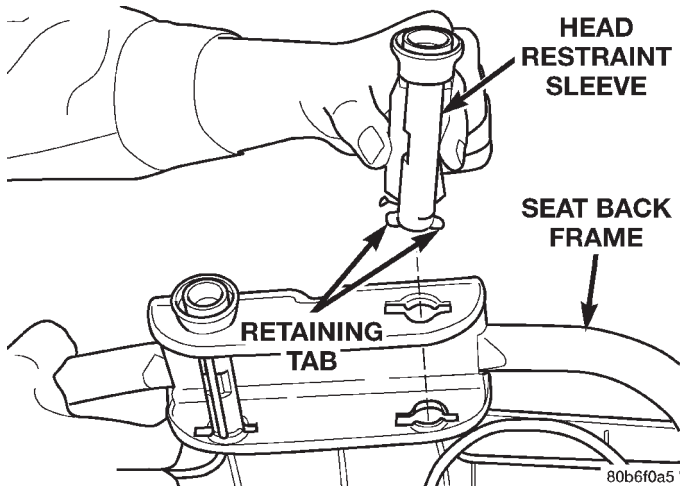

Fig. 6 Head Restraint Sleeve

- (2) Rotate head restraint sleeve 1/4 turn clockwise to engage retaining tab.
- (3) Install cushion pad onto seat back frame.
- (4) Install hog rings attaching cushion pad to seat back frame.
- (5) Install seat back cover.
- (6) Install seat back.
- (7) Install head restraint.

BUCKET SEAT BACK COVER

REMOVAL

- (1) Remove head restraint.
- (2) Using a trim stick, carefully pry head restraint release button caps from the top of seat back.
- (3) Remove seat back.
- (4) Disengage J-strap at base of seat back.
- (5) Slide hand between the face of the seat back pad and the cushion cover and carefully separate hook and loop fastener (Fig. 7).
- (6) Roll cover upward and disengage hog rings.
- (7) Roll cover upward to top of seat back.
- (8) Separate cover from seat back.

INSTALLATION

- (1) Position cover inside-out at the top of seat back.
- (2) Roll cover downward.
- (3) Engage hog rings.
- (4) Align seat back cover with hook and loop fasteners and secure.
- (5) Roll cover downward.
- (6) Engage J-strap at base of seat back.
- (7) Install seat back.

NOTE: The taller head restraint release button cap is positioned on the left hand side and the head restraint button cap with the hidden button is positioned on the right hand side.

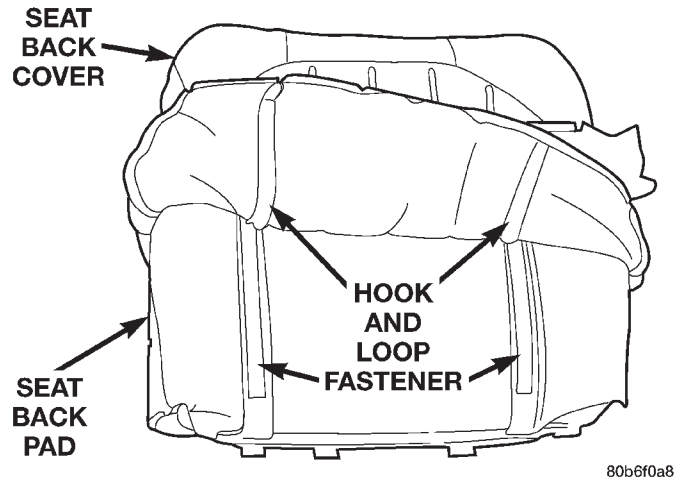

Fig. 7 Seat Back Cover

- (8) Position head restraint release button caps on head restraint sleeves and press to secure.
- (9) Install head restraint.

BUCKET SEAT CUSHION COVER

REMOVAL

- (1) Remove seat from vehicle.
- (2) Remove seat back.
- (3) Disengage J-straps attaching cushion cover to seat cushion frame.
- (4) Disengage hog rings attaching cushion cover to cushion frame (Fig. 8).
- (5) Route seat function switches through access hole on outboard side of seat cushion, if equipped.
- (6) Disengage seat cushion heater element connector, if equipped.
- (7) Separate seat cushion cover from seat cushion.

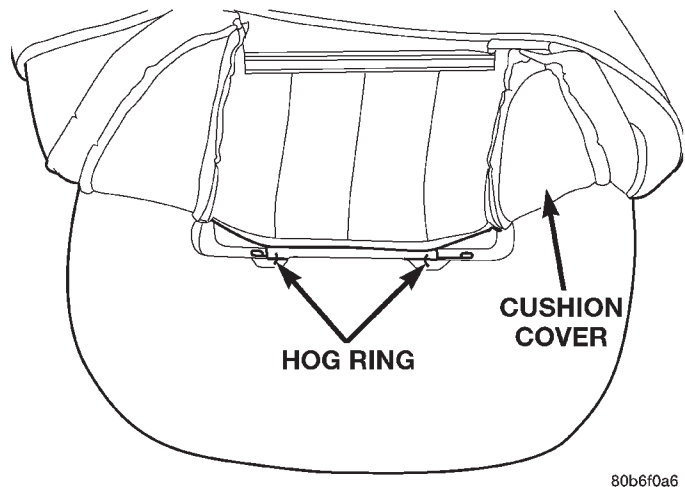

Fig. 8 Seat Cushion Cover

INSTALLATION

- (1) Position seat cover on cushion.

REMOVAL AND INSTALLATION (Continued)

- (2) Engage seat cushion heater element connector, if equipped.
- (3) Route seat function switches through access hole on outboard side of seat cushion, if equipped.
- (4) Engage J-straps attaching cushion cover to seat cushion frame.
- (5) Engage hog rings attaching cushion cover to cushion frame.
- (6) Install seat back.
- (7) Install seat.

REAR SEAT CUSHION RELEASE LATCH

REMOVAL

- (1) Unlatch seat and pivot seat upward.
- (2) Disengage J-strap at seat cushion base panel.
- (3) Roll back cushion cover.
- (4) Remove screws attaching latch to base panel.
- (5) Separate latch from base panel.

INSTALLATION

- (1) Position latch on base panel.
- (2) Install screws attaching latch to base panel. Tighten screws to 8 N·m (75 in. lbs.) torque.
- (3) Route the cushion release strap from the loop on the latch through the slot in the trim cover.
- (4) Engage J-strap at seat cushion base panel.
- (5) Latch seat.

REAR SEAT CUSHION

REMOVAL

- (1) Disengage seat cushion at rear by pulling upward on release strap.
- (2) Remove bolts attaching seat cushion to floor pan (Fig. 9).
- (3) Remove seat cushion from vehicle.

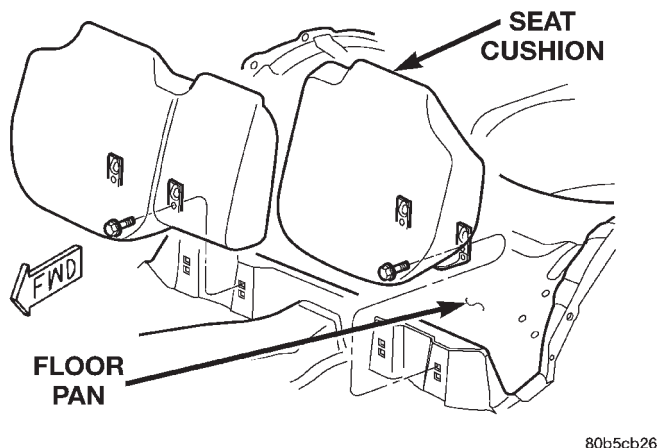

Fig. 9 Rear Seat Cushion

INSTALLATION

- (1) Position seat cushion in vehicle.
- (2) Install bolts attaching seat cushion to floor pan. Tighten bolts to 11 N·m (8 ft. lbs.) torque.
- (3) Lock seat cushion down by pressing firmly on center of cushion until latch engages.

REAR SEAT CUSHION COVER

REMOVAL

- (1) Remove rear seat cushion.
- (2) From the underside of the seat, disengage J-straps attaching cover to seat cushion base panel.
- (3) Remove push-in fasteners attaching cushion cover to seat cushion base panel (Fig. 10).
- (4) Roll back cover.
- (5) Disengage hog rings attaching cushion cover to seat cushion foam pad.
- (6) Separate cushion cover from seat cushion base panel.

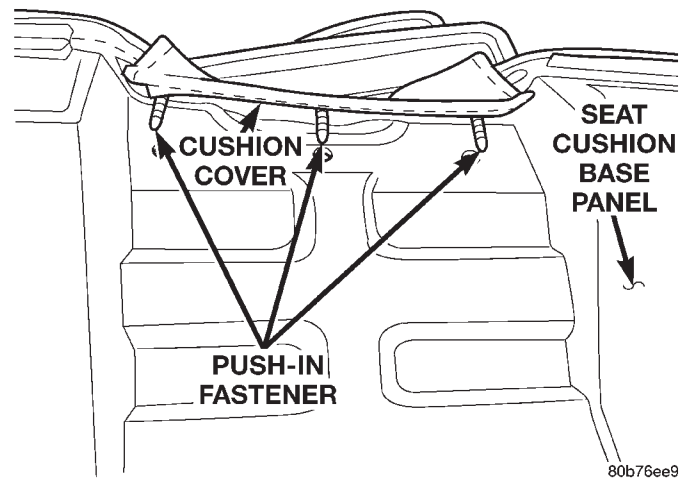

Fig. 10 Push-in Fasteners

INSTALLATION

- (1) Position cushion cover on seat cushion base panel.
- (2) Engage hog rings attaching cushion cover to seat cushion foam pad.
- (3) Align cushion cover and engage J-straps attaching cushion cover to seat cushion base panel.
- (4) Install push-in fasteners attaching cushion cover to seat cushion base panel.
- (5) Install rear seat cushion.

REAR SEAT BACK LATCH RELEASE HANDLE

REMOVAL

- (1) Pull handle to release latch.
- (2) Remove screws attaching release handle to seat back frame.

REMOVAL AND INSTALLATION (Continued)

- (3) Using a small flat blade, disengage retainers securing latch release cable housing to latch release handle.
- (4) Rotate cable end until barrel end aligns with key hole slot in latch release handle.
- (5) Disengage cable barrel end from release handle.
- (6) Separate latch release handle from seat back (Fig. 11).

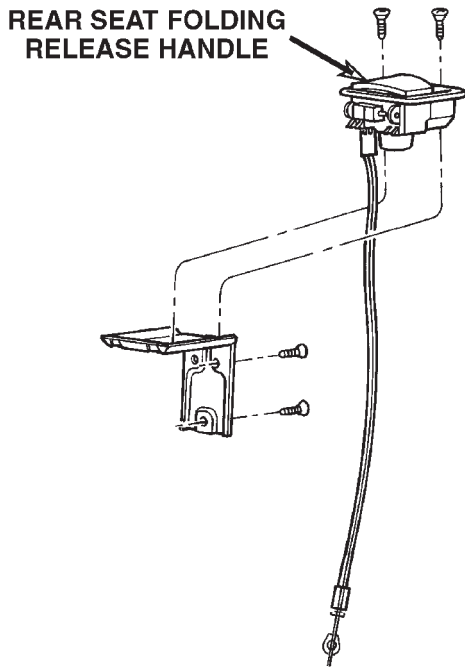

Fig. 11 Rear Seat Release Handle

INSTALLATION

- (1) Route cable end into latch release handle.
- (2) Rotate cable end until barrel end aligns with key hole slot in latch release handle and insert into handle.
- (3) Engage retainers securing latch release cable housing to latch release handle.
- (4) Position latch release handle in seat back. Ensure seat back cover is properly aligned.
- (5) Install screws attaching release handle to seat back frame.

REAR SEATBACK

REMOVAL

- (1) Move rear seat cushions to forward cargo position.
- (2) Remove bolts attaching seatback side support bracket to floor pan (right side) (Fig. 12).
- (3) Tilt seatback forward, and slide it outboard to detach it from pin on center pivot bracket.
- (4) Remove right side (60%) seatback from vehicle.

- (5) Remove bolts attaching seatback side support bracket and center pivot bracket to floor pan (left side).
- (6) Remove left side (40%) seatback from vehicle.

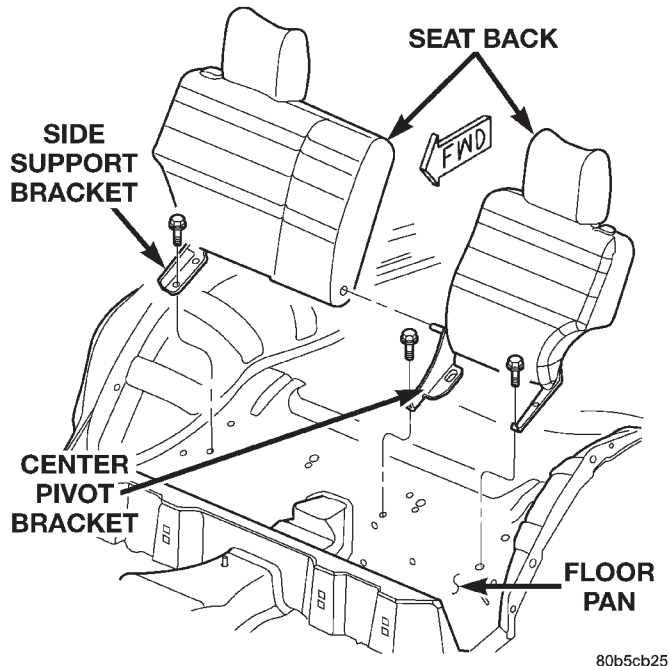

Fig. 12 Rear Seat Back

INSTALLATION

- (1) Position left side (40%) seatback in vehicle.
- (2) Position left side support bracket and center pivot bracket with bolt holes aligned and install bolts. Tighten bolts to 28 N·m (20 ft. lbs.) torque.
- (3) Position right side (60%) seatback in vehicle.
- (4) Install seatback onto center pivot bracket pin. Ensure seat back is properly engaged on the center pivot pin.
- (5) Position right side support bracket with bolt holes aligned and install bolts. Tighten bolts to 28 N·m (20 ft. lbs.) torque.
- (6) Return seat cushions to seating position.

REAR SEAT BACK LATCH/HINGE

REMOVAL

- (1) Remove seat back.
- (2) Disengage J-straps on outboard side of seat back.
- (3) Disengage latch release cable.
- (4) Remove bolts attaching latch/hinge to seat back frame.
- (5) Separate latch/hinge from seat back frame.

INSTALLATION

- (1) Position latch/hinge on seat back frame.

80ba780a

80b5cb25

REMOVAL AND INSTALLATION (Continued)

- (2) Install bolts attaching latch/hinge to seat back frame. Tighten bolts to 28 N·m (20 ft. lbs.) torque.
- (3) Engage latch release cable.
- (4) Engage J-straps on outboard side of seat back.
- (5) Install seat back.

REAR SEAT BACK COVER

REMOVAL

- (1) Remove seat back.
- (2) Remove head restraint.
- (3) Remove head restraint caps.
- (4) Disengage J-straps on outboard side of seat back.
- (5) Disengage J-straps at base of seat back.
- (6) Remove screws attaching latch release handle to seat back frame.
- (7) Roll seat back cover upward.
- (8) Disengage hook and loop fasteners attaching seat back cover to seat back pad (Fig. 13).
- (9) Roll seat back cover upward and route latch release handle through seat back cover.
- (10) Separate seat back cover from seat back.
- (11) Separate seat back pad from seat back frame.

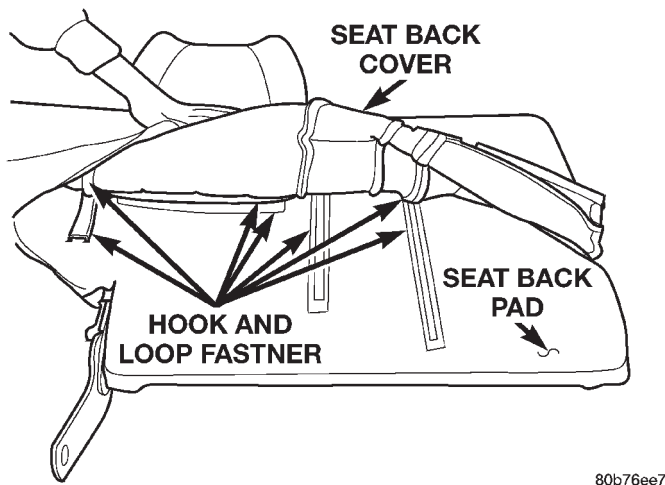

Fig. 13 Rear Seat Back Cover

INSTALLATION

- (1) Position seat back cover on seat back.
- (2) Route latch release handle through seat back cover.
- (3) Roll seat back cover partially downward aligning holes in seat back cover for head restraint and latch release handle.
- (4) Roll seat back cover downward align and engage hook and loop fasteners to seat back pad.
- (5) Engage J-straps at base of seat back.
- (6) Engage J-straps on outboard side of seat back.
- (7) Install screws attaching latch release handle to seat back frame.
- (8) Install head restraint.

- (9) Install seat back.

REAR SEAT HEAD REST

REMOVAL

- (1) Depress head rest release button and lift head rest to full up position.
- (2) Using a small flat blade, depress tab on outboard side head rest release button and using your hand, simultaneously press tab on inboard side head rest release button (Fig. 14) and pull head rest up to separate from seat back.

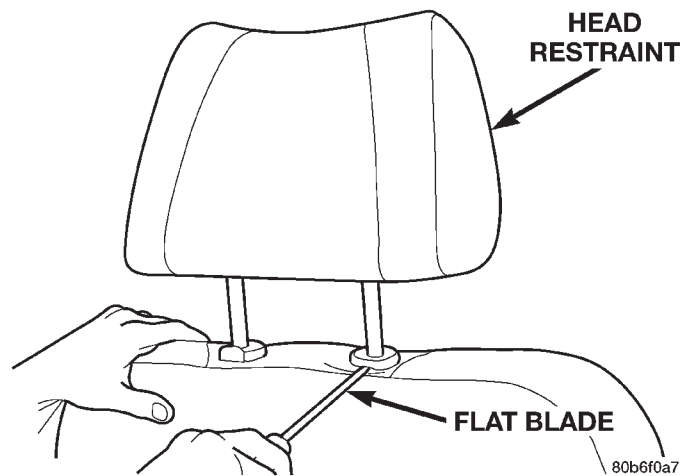

Fig. 14 Head Rest

INSTALLATION

- (1) Position head rest in seat back, press tab on inboard side head rest release button cap and push down to secure.

REAR SEAT FOLDING HEAD REST RELEASE KNOB

The release knob is not salvageable during the removal process. The knob should only be replaced if damaged or broken. Check availability before servicing.

REMOVAL

- (1) Using a E-XACTO knife or equivalent, cut the release knob from the release lever.
- (2) Pull the release knob from the lever (Fig. 15).

INSTALLATION

- (1) Position the release knob on the lever and press to snap in place.

REAR SEAT HEAD REST SLEEVE

REMOVAL

- (1) Remove seat back.
- (2) Remove head rest.

REMOVAL AND INSTALLATION (Continued)

- (3) Remove head rest caps.
- (4) Remove seat back cover.
- (5) Rotate head rest sleeve 1/4 turn counter-clockwise to release retaining tab.
- (6) Pull sleeve from seat back frame.

INSTALLATION

- (1) Position sleeve in seat back frame.
- (2) Rotate head rest sleeve 1/4 turn clockwise to engage retaining tab.
- (3) Install seat back cover.
- (4) Install head rest caps.

NOTE: The head rest cap with the taller button is always on the inboard side of the seat back.

- (5) Install the head rest.

NOTE: The folding head rest release knob is always on the outboard side.

- (6) Install the seat back.

REAR SEAT HEAD REST FOLDING MECHANISM

REMOVAL

- (1) Remove the head rest.
- (2) Remove folding mechanism cover (Fig. 15).
- (3) Remove the screws that secure the head rest bun to the folding mechanism.

NOTE: The folding release knob is always located on the outboard side.

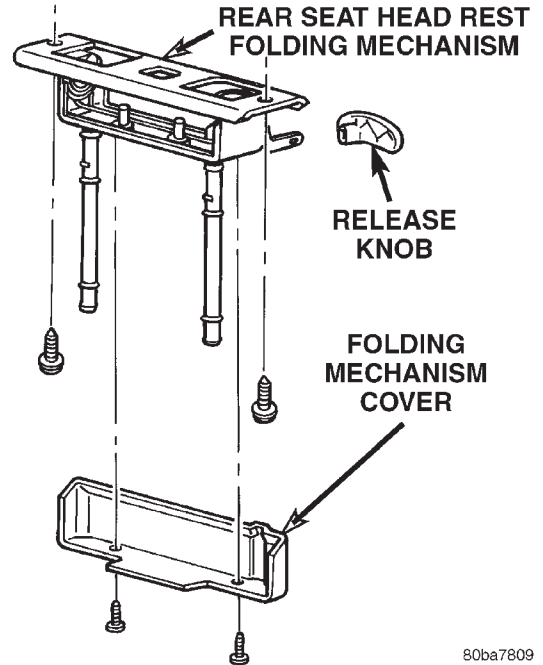

80ba7809

Fig. 15 Rear Seat Head Rest Folding Mechanism

INSTALLATION

- (1) Position the head rest bun on the folding mechanism and install the screws.
- (2) Install the folding mechanism cover.
- (3) Install the head restraint.

BODY COMPONENTS

INDEX

	page		page
DESCRIPTION AND OPERATION		FRONT DOOR WATERDAM	32
COMPONENT FASTENERS	23	FRONT DOOR WINDOW REGULATOR	37
DIAGNOSIS AND TESTING		FRONT FENDER	30
UNIVERSAL TRANSMITTER	24	FRONT SHOULDER BELT	50
WATER LEAKS	23	FRONT SHOULDER BELT BUCKLE	50
WIND NOISE	24	FUEL FILL DOOR	44
SERVICE PROCEDURES		GRILLE	25
BODY LUBRICATION	25	HEADLAMP MOUNTING MODULE (HMM)	26
DRILLING AND WELDING PROCEDURES	25	HEADLINER	53
REMOVAL AND INSTALLATION		HOOD	26
A-PILLAR TRIM	46	HOOD HINGE	27
B-PILLAR LOWER TRIM	47	HOOD INSULATION PANEL	26
B-PILLAR UPPER TRIM	47	HOOD LATCH	27
BODY SIDE CLADDING	45	HOOD RELEASE CABLE	28
C-PILLAR UPPER TRIM	48	HOOD SEAL	26
CARGO AREA CARPET	52	HOOD SUPPORT PROP	26
COWL COVER	29	LICENSE PLATE LAMP HOUSING	60
COWL LOWER TRIM	47	LIFTGATE	56
COWL PLENUM SEAL	28	LIFTGATE HINGE	56
D-PILLAR AIR EXHAUSTER	60	LIFTGATE INSULATOR	55
D-PILLAR APPLIQUE	60	LIFTGATE LATCH	57
D-PILLAR TRIM	50	LIFTGATE LATCH STRIKER	57
EXTERIOR NAMEPLATES	29	LIFTGATE OPENING WEATHERSTRIP	57
FLIP UP GLASS	58	LIFTGATE OUTSIDE HANDLE	56
FLIP UP GLASS LATCH	59	LIFTGATE TRIM PANEL	54
FLIP UP GLASS LATCH STRIKER	59	LOWER LIFTGATE OPENING TRIM PANEL	54
FLIP UP GLASS SWITCH	59	LUGGAGE RACK	60
FLIP UP GLASS WEATHERSTRIP	59	OVERHEAD ASSIST HANDLE	47
FLOOR CONSOLE	51	QUARTER PANEL TRIM	49
FRONT CARPET	51	REAR DOOR	39
FRONT DOOR	32	REAR DOOR B-PILLAR SEAL	38
FRONT DOOR CHECK	32	REAR DOOR CHECK	39
FRONT DOOR GLASS	37	REAR DOOR HINGE	40
FRONT DOOR GLASS RUN CHANNEL	36	REAR DOOR INNER BELT WEATHERSTRIP	42
FRONT DOOR GLASS RUN CHANNEL WEATHERSTRIP	35	REAR DOOR INSIDE HANDLE ACTUATOR	41
FRONT DOOR HINGE	33	REAR DOOR LATCH	41
FRONT DOOR INNER BELT SEAL	35	REAR DOOR LATCH STRIKER	41
FRONT DOOR INSIDE HANDLE ACTUATOR	34	REAR DOOR OPENING WEATHERSTRIP	42
FRONT DOOR LATCH	34	REAR DOOR OUTER BELT WEATHERSTRIP	42
FRONT DOOR LATCH STRIKER	34	REAR DOOR OUTSIDE HANDLE	40
FRONT DOOR LOCK CYLINDER	34	REAR DOOR SCUFF PLATE	48
FRONT DOOR OPENING WEATHERSTRIP	36	REAR DOOR SECONDARY WEATHERSTRIP	42
FRONT DOOR OUTER BELT SEAL	35	REAR DOOR STATIONARY GLASS	44
FRONT DOOR OUTSIDE HANDLE	33	REAR DOOR TRIM PANEL	38
FRONT DOOR SCUFF PLATE	47	REAR DOOR WATERDAM	39
FRONT DOOR SECONDARY WEATHERSTRIP	36	REAR DOOR WINDOW GLASS	43
FRONT DOOR TRIM PANEL	30	REAR DOOR WINDOW REGULATOR	43
		REAR SEAT BELT BUCKLE	50
		REARVIEW MIRROR	52

REARVIEW MIRROR SUPPORT BRACKET 52
 ROOF RAIL WEATHERSTRIP W/RETAINER 44
 SIDE VIEW MIRROR 29
 SIDE VIEW MIRROR GLASS 29
 SILL MOLDING 45
 STORAGE BIN 50
 SUNVISOR 53
 TAIL LAMP AIR EXHAUSTER 60
 UPPER LIFTGATE OPENING TRIM PANEL 55
ADJUSTMENTS
 DOOR ADJUSTMENT 61
 DOOR LATCH 61

HOOD ADJUSTMENT 61
 LIFTGATE ADJUSTMENT 61
SPECIFICATIONS
 BODY GAP AND FLUSH MEASUREMENTS 168
 BODY LUBRICANTS 62
 BODY OPENING DIMENSIONS 170
 SEALER LOCATIONS 125
 STRUCTURAL ADHESIVE LOCATIONS 147
 TORQUE SPECIFICATIONS 173
 WELD LOCATIONS 63
SPECIAL TOOLS
 BODY 173

DESCRIPTION AND OPERATION

COMPONENT FASTENERS

Chrysler Corporation uses many different types of push-in fasteners to secure the interior and exterior trim to the body. Most of these fasteners can be reused to assemble the trim during various repair procedures. At times, a push-in fastener cannot be removed without damaging the fastener or the component it is holding. If it is not possible to remove a fastener without damaging a component or body, cut or break the fastener and use a new one when installing the component. Never pry or pound on a plastic or pressed-board trim component. Using a suitable fork-type prying device, pry the fastener from the retaining hole behind the component being removed. When installing, verify fastener alignment with the retaining hole by hand. Push directly on or over the fastener until it seats. Apply a low-force pull to the panel to verify that it is secure.

When it is necessary to remove components to service another, it should not be necessary to apply excessive force or bend a component to remove it. Before damaging a trim component, verify hidden fasteners or captured edges holding the component in place.

DIAGNOSIS AND TESTING

WATER LEAKS

Water leaks can be caused by poor sealing, improper body component alignment, body seam porosity, missing plugs, or blocked drain holes. Centrifugal and gravitational force can cause water to drip from a location away from the actual leak point, making leak detection difficult. All body sealing points should be water tight in normal wet-driving conditions. Water flowing downward from the front of the vehicle should not enter the passenger or luggage compartment. Moving sealing surfaces will not always seal water tight under all conditions. At times, side glass or door seals will allow water to

enter the passenger compartment during high pressure washing or hard driving rain (severe) conditions. Overcompensating on door or glass adjustments to stop a water leak that occurs under severe conditions can cause premature seal wear and excessive closing or latching effort. After completing a repair, water test vehicle to verify leak has stopped before returning vehicle to use.

VISUAL INSPECTION BEFORE WATER LEAK TESTS

Verify that floor and body plugs are in place, body drains are clear, and body components are properly aligned and sealed. If component alignment or sealing is necessary, refer to the appropriate section of this group for proper procedures.

WATER LEAK TESTS

WARNING: DO NOT USE ELECTRIC SHOP LIGHTS OR TOOLS IN WATER TEST AREA. PERSONAL INJURY CAN RESULT.

When the conditions causing a water leak have been determined, simulate the conditions as closely as possible.

- If a leak occurs with the vehicle parked in a steady light rain, flood the leak area with an open-ended garden hose.
- If a leak occurs while driving at highway speeds in a steady rain, test the leak area with a reasonable velocity stream or fan spray of water. Direct the spray in a direction comparable to actual conditions.
- If a leak occurs when the vehicle is parked on an incline, hoist the end or side of the vehicle to simulate this condition. This method can be used when the leak occurs when the vehicle accelerates, stops or turns. If the leak occurs on acceleration, hoist the front of the vehicle. If the leak occurs when braking, hoist the back of the vehicle. If the leak occurs on left turns, hoist the left side of the vehicle. If the leak occurs on right turns, hoist the right side of the vehicle. For hoisting recommendations refer to Group 0, Lubrication and Maintenance, General Information section.

DIAGNOSIS AND TESTING (Continued)

WATER LEAK DETECTION

To detect a water leak point-of-entry, do a water test and watch for water tracks or droplets forming on the inside of the vehicle. If necessary, remove interior trim covers or panels to gain visual access to the leak area. If the hose cannot be positioned without being held, have someone help do the water test.

Some water leaks must be tested for a considerable length of time to become apparent. When a leak appears, find the highest point of the water track or drop. The highest point usually will show the point of entry. After leak point has been found, repair the leak and water test to verify that the leak has stopped.

Locating the entry point of water that is leaking into a cavity between panels can be difficult. The trapped water may splash or run from the cavity, often at a distance from the entry point. Most water leaks of this type become apparent after accelerating, stopping, turning, or when on an incline.

MIRROR INSPECTION METHOD

When a leak point area is visually obstructed, use a suitable mirror to gain visual access. A mirror can also be used to deflect light to a limited-access area to assist in locating a leak point.

BRIGHT LIGHT LEAK TEST METHOD

Some water leaks in the luggage compartment can be detected without water testing. Position the vehicle in a brightly lit area. From inside the darkened luggage compartment inspect around seals and body seams. If necessary, have a helper direct a drop light over the suspected leak areas around the luggage compartment. If light is visible through a normally sealed location, water could enter through the opening.

PRESSURIZED LEAK TEST METHOD

When a water leak into the passenger compartment cannot be detected by water testing, pressurize the passenger compartment and soap test exterior of the vehicle. To pressurize the passenger compartment, close all doors and windows, start engine, and set heater control to high blower in HEAT position. If engine can not be started, connect a charger to the battery to ensure adequate voltage to the blower. With interior pressurized, apply dish detergent solution to suspected leak area on the exterior of the vehicle. Apply detergent solution with spray device or soft bristle brush. If soap bubbles occur at a body seam, joint, seal or gasket, the leak entry point could be at that location.

WIND NOISE

Wind noise is the result of most air leaks. Air leaks can be caused by poor sealing, improper body component alignment, body seam porosity, or missing plugs in the engine compartment or door hinge pillar areas. All body sealing points should be airtight in normal driving conditions. Moving sealing surfaces will not always seal airtight under all conditions. At times, side glass or door seals will allow wind noise to be noticed in the passenger compartment during high cross winds. Over compensating on door or glass adjustments to stop wind noise that occurs under severe conditions can cause premature seal wear and excessive closing or latching effort. After a repair procedure has been performed, test vehicle to verify noise has stopped before returning vehicle to use.

Wind noise can also be caused by improperly fitted exterior moldings or body ornamentation. Loose moldings can flutter, creating a buzzing or chattering noise. An open cavity or protruding edge can create a whistling or howling noise. Inspect the exterior of the vehicle to verify that these conditions do not exist.

VISUAL INSPECTION BEFORE TESTS

Verify that floor and body plugs are in place and body components are aligned and sealed. If component alignment or sealing is necessary, refer to the appropriate section of this group for proper procedures.

ROAD TESTING WIND NOISE

(1) Drive the vehicle to verify the general location of the wind noise.

(2) Apply 50 mm (2 in.) masking tape in 150 mm (6 in.) lengths along weatherstrips, weld seams or moldings. After each length is applied, drive the vehicle. If noise goes away after a piece of tape is applied, remove tape, locate, and repair defect.

POSSIBLE CAUSE OF WIND NOISE

- Moldings standing away from body surface can catch wind and whistle.
- Gaps in sealed areas behind overhanging body flanges can cause wind-rushing sounds.
- Misaligned movable components.
- Missing or improperly installed plugs in pillars.
- Weld burn through holes.

UNIVERSAL TRANSMITTER

Universal Transmitter will operate most:

- Garage door opener
- Gate opener
- Home/Office lighting and/or security system(s)

The transmitter is powered by the M1 circuit that supplies voltage to the driver side visor/vanity lamp.

DIAGNOSIS AND TESTING (Continued)

TRAINING THE UNIVERSAL TRANSMITTER

To train the transmitter refer to the Owner's Manual.

TESTING TRANSMITTER

(1) Check for battery voltage at the Universal Transmitter by pressing a button and seeing if a red lamp comes on. If OK, go to Step 6. If not OK, go to Step 2.

(2) Check if visor/vanity lamp lights. If lamp lights, replace visor. If lamp does not light go to Step 3.

(3) Check fuse. If OK, go to Step 4. If not OK, repair as necessary.

(4) Remove visor and test M1 wire for battery voltage at the visor connector. If voltage is OK, go to Step 5. If no voltage repair wire as necessary. Refer to Group 8W, Wiring Diagrams for proper terminals.

(5) Test Z1 wire for ground at the visor connector. If ground is OK, replace visor. If no ground repair wire as necessary.

(6) Check the instructions in the Owner's Manual and retrain the transmitter. If the transmitter can not be trained replace visor.

SERVICE PROCEDURES**BODY LUBRICATION**

All mechanisms and linkages should be lubricated when necessary. This will maintain ease of operation and provide protection against rust and excessive wear. The weatherstrip seals should be lubricated to prolong their life as well as to improve door sealing.

All applicable exterior and interior vehicle operating mechanisms should be inspected and cleaned. Pivot/sliding contact areas on the mechanisms should then be lubricated.

(1) When necessary, lubricate the operating mechanisms with the specified lubricants.

(2) Apply silicone lubricant to a cloth and wipe it on door seals to avoid over-spray that can soil passenger's clothing.

(3) Before applying lubricant, the component should be wiped clean. After lubrication, any excess lubricant should be removed.

(4) The hood latch, latch release mechanism, latch striker, and safety latch should be lubricated periodically.

(5) The door lock cylinders should be lubricated twice each year (preferably autumn and spring).

- Spray a small amount of lock cylinder lubricant directly into the lock cylinder.

- Apply a small amount to the key and insert it into the lock cylinder.

- Rotate it to the locked position and then back to the unlocked position several times.
- Remove the key. Wipe the lubricant from it with a clean cloth to avoid soiling of clothing.

DRILLING AND WELDING PROCEDURES

When holes must be drilled or punched in an inner body panel, verify depth of space to the outer body panel, electrical wiring, or other components. Damage to vehicle can result.

Do not weld exterior panels unless combustible material on the interior of vehicle is removed from the repair area. Fire or hazardous conditions, can result.

Always have a fire extinguisher ready for use when welding.

REMOVAL AND INSTALLATION**GRILLE**

The grille is incorporated into the fascia. To replace or service the grille, the fascia must be removed. The grille is equipped with an insert which can be serviced.

REMOVAL

- (1) Remove fascia.
- (2) Disengage retainers attaching grille insert to grille/fascia.
- (3) Separate grille insert from grille/fascia (Fig. 1).

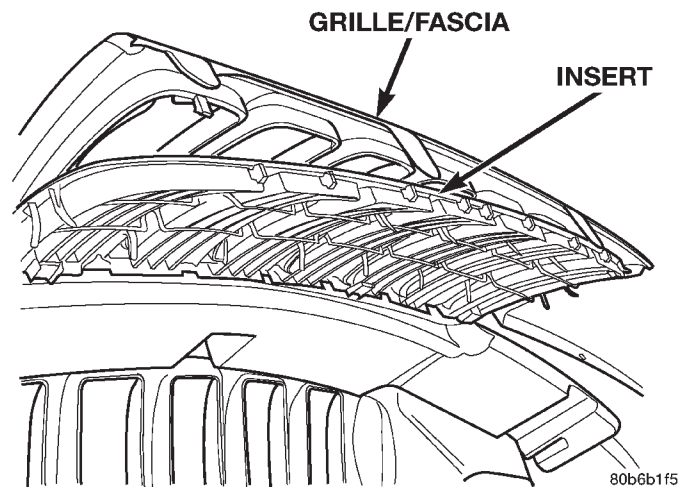

Fig. 1 Grille Insert

INSTALLATION

- (1) Position grille insert in grille/fascia.
- (2) Engage retainers attaching grille insert to grille/fascia.
- (3) Install fascia.

REMOVAL AND INSTALLATION (Continued)

HOOD SEAL

REMOVAL

- (1) Raise hood.
- (2) Pull hood seal from upper radiator crossmember.
- (3) Separate seal from upper radiator crossmember (Fig. 2).

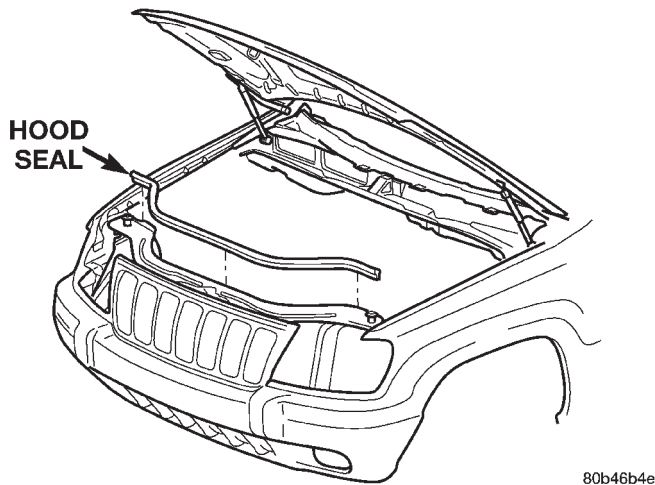

Fig. 2 Hood Seal

INSTALLATION

- (1) Position seal on upper radiator crossmember.
- (2) Press seal onto upper radiator crossmember to seat.

HEADLAMP MOUNTING MODULE (HMM)

REMOVAL

CAUTION: Take special care when handling the HMM not to damage the upper mounting tabs. Step #3 must be performed prior to removing HMM from the vehicle to prevent damage to HMM.

- (1) Remove front fascia.
- (2) Remove front wheelhouse splash shields.
- (3) Reach into the wheelhouse opening and disengage the retainer attaching the HMM to each side of the body.
- (4) Remove bolts attaching headlamp mounting module to body (Fig. 3).
- (5) Disconnect headlamp wire harness connectors.
- (6) Separate headlamp mounting module from vehicle.

INSTALLATION

- (1) Position headlamp mounting module at vehicle.
- (2) Connect headlamp wire harness connectors.
- (3) Engage the retainer attaching the HMM to each side of the body.

- (4) Install bolts attaching headlamp mounting module to body (Fig. 3).
- (5) Install front wheelhouse splash shields.
- (6) Install front fascia.

HOOD

REMOVAL

- (1) Raise hood.
- (2) If equipped, disconnect underhood lamp harness connector. (Connector is located under cowl cover).
- (3) Using a wax crayon or equivalent, mark location of hood hinges on hood for installation alignment.
- (4) Support hood in the open position.
- (5) Remove hood support prop rods.
- (6) Remove bolts attaching hinges to hood.
- (7) With the aid of a helper, remove hood from vehicle.

INSTALLATION

- (1) Position hood on hinges.
- (2) Install bolts finger-tight.
- (3) Align hinges with installation reference marks and tighten bolts.
- (4) Install hood support prop rods.
- (5) Connect underhood lamp connector.
- (6) Inspect hood for proper alignment and adjust as necessary.

HOOD INSULATION PANEL

REMOVAL

- (1) Raise the hood.
- (2) Remove the insulation panel fasteners.
- (3) Remove the hood insulation panel.

INSTALLATION

- (1) Position the insulation panel on the underside of the hood.
- (2) Install the insulation panel fasteners.
- (3) Close the hood.

HOOD SUPPORT PROP

REMOVAL

- (1) Raise and support hood.
- (2) Using a small flat blade, pry the retainer attaching hood support prop to lower ball stud.
- (3) Slide retainer attaching hood support prop upper ball stud downward.
- (4) Disconnect hood support prop from lower ball stud and rotate support prop upward and disconnect from upper ball stud (Fig. 4).

REMOVAL AND INSTALLATION (Continued)

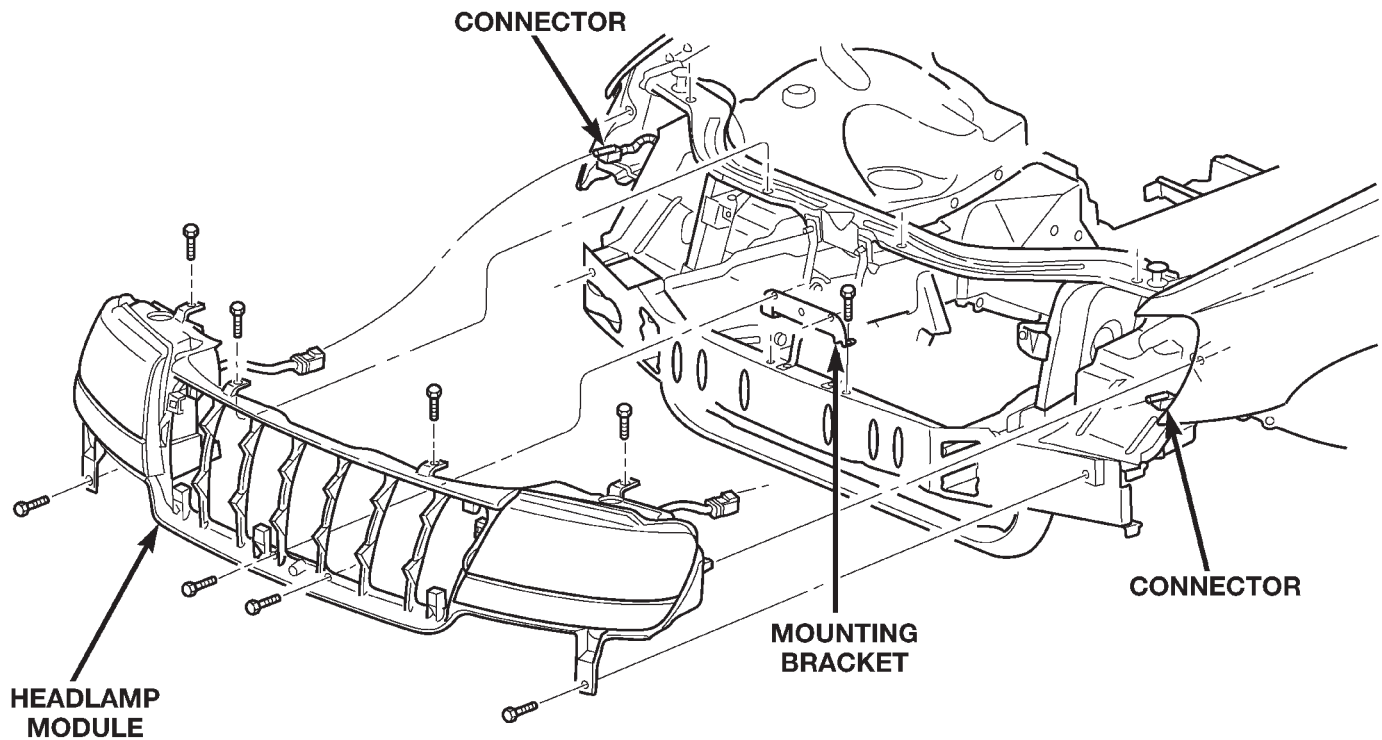

80b46cd0

Fig. 3 Headlamp Mounting Module

HOOD HINGE

REMOVAL

- (1) Raise and support hood.
- (2) Using a wax crayon or equivalent, mark position of hinge.
- (3) Remove hood hinge prop rod.
- (4) Remove nuts attaching hinge to hood (Fig. 4).
- (5) Remove bolts attaching hinge to body.
- (6) Separate hinge from vehicle.

INSTALLATION

- (1) Position hinge on vehicle and align reference marks.
- (2) Install bolts attaching hinge to body.
- (3) Install nuts attaching hinge to hood.
- (4) Install hood hinge prop rod.

HOOD LATCH

REMOVAL

- (1) Remove nuts attaching latch to radiator cross-member support (Fig. 5).
- (2) Disconnect hood release cable from latch.
- (3) Separate latch from vehicle.

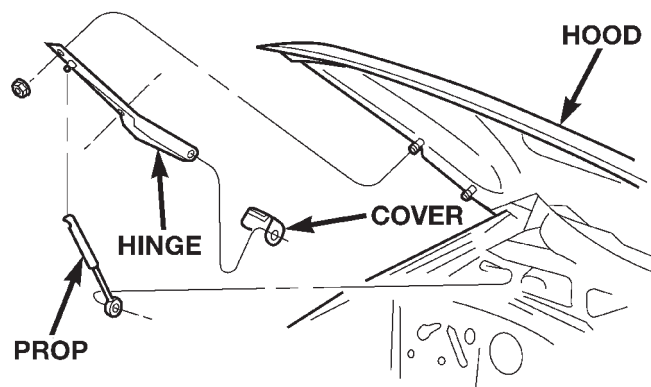

80b3c6fc

Fig. 4 Hood Support Prop

INSTALLATION

- (1) Position hood support prop on upper ball stud.
- (2) Slide retainer upward to secure support prop to upper ball stud.
- (3) Position support prop on lower ball stud and press retainer inward to secure.

REMOVAL AND INSTALLATION (Continued)

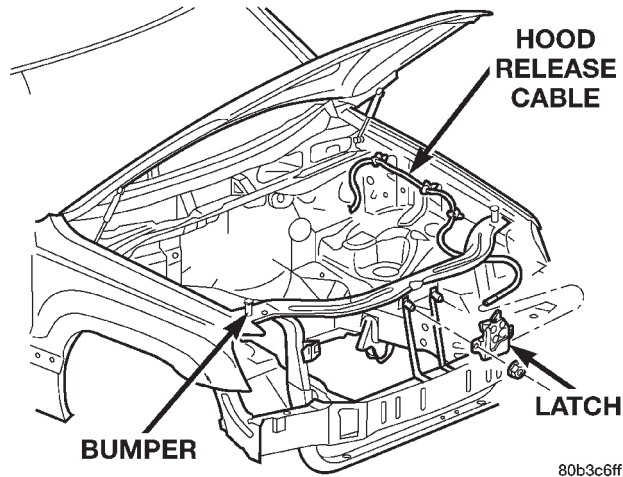

80b3c6ff

Fig. 5 Hood Latch**INSTALLATION**

- (1) Connect latch release cable to latch.
- (2) Position latch on radiator crossmember support.
- (3) Install nuts attaching latch to radiator crossmember support. Tighten nuts to 11 N·m (8 ft. lbs.) torque.

HOOD RELEASE CABLE**REMOVAL**

- (1) Disconnect cable from hood latch (Fig. 6).
- (2) Disconnect cable from retaining clips on left inner fender panel.
- (3) Remove left cowl side trim panel.
- (4) Remove fasteners attaching cable bracket to cowl side panel (Fig. 7).
- (5) Route cable through dash panel and remove it from under instrument panel.

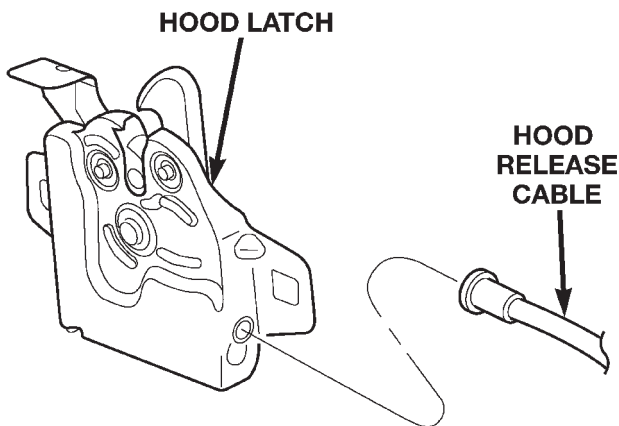

80b3c70a

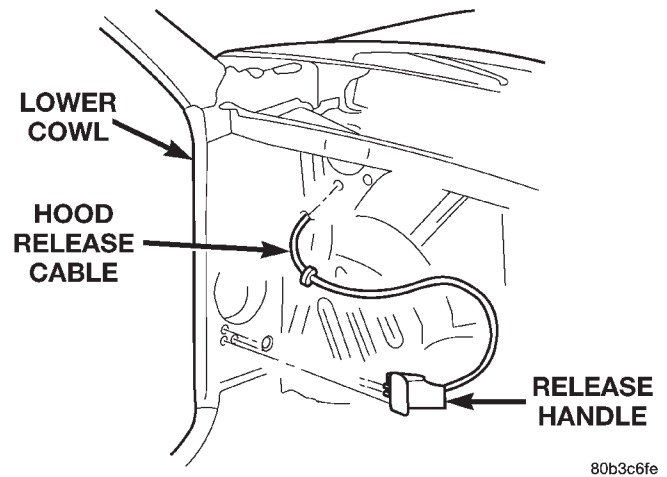
Fig. 6 Hood Latch

80b3c6fe

Fig. 7 Hood Release Cable**INSTALLATION**

- (1) Route cable through hole in dash panel into engine compartment.
- (2) Pull cable forward and seat grommet in dash panel.
- (3) Position cable bracket on cowl side panel and install fasteners.
- (4) Install left cowl side trim panel.
- (5) Route and install cable in retaining clips on left inner fender panel.
- (6) Connect cable to hood latch.

COWL PLENUM SEAL**REMOVAL**

- (1) Raise hood.
- (2) Pull cowl plenum seal from cowl.
- (3) Separate cowl plenum seal from cowl (Fig. 8).

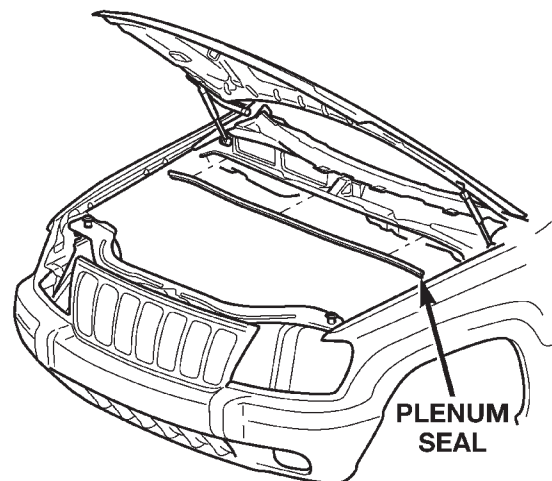

80b46b4d

Fig. 8 Cowl Plenum Seal**INSTALLATION**

- (1) Position cowl plenum seal on cowl.
- (2) Press cowl plenum seal to seat.

REMOVAL AND INSTALLATION (Continued)

COWL COVER

REMOVAL

- (1) Remove wiper arms.
- (2) Remove plenum seal.
- (3) Remove plastic push nuts attaching cowl cover to cowl (Fig. 9).
- (4) Remove windshield washer tubes at connector.
- (5) Remove cowl cover from cowl.

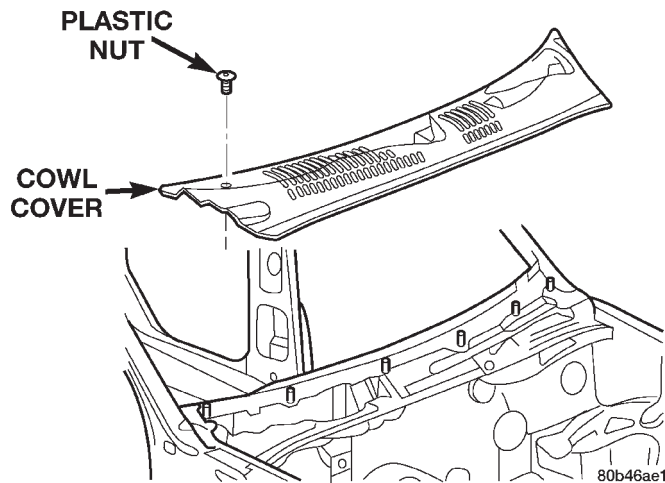

Fig. 9 Cowl Cover

INSTALLATION

- (1) Position cowl cover on cowl.
- (2) Install windshield washer tubes at connector.
- (3) Install plastic push nuts attaching cowl cover to cowl.
- (4) Install plenum seal.
- (5) Install windshield wiper arms.

EXTERIOR NAMEPLATES

REMOVAL

NOTE: Exterior nameplates are attached to body panels with adhesive tape.

- (1) Apply a length of masking tape on the body, parallel to the top edge of the nameplate to use as a guide, if necessary.
- (2) If temperature is below 21°C (70°F) warm emblem with a heat lamp or gun. Do not exceed 52°C (120°F) when heating emblem.
- (3) Insert a plastic trim stick or a hard wood wedge behind the emblem to separate the adhesive backing from the body.
- (4) Clean adhesive residue from body with MOPAR Super Clean solvent or equivalent.

INSTALLATION

- (1) Remove protective cover from adhesive tape on back of emblem.
- (2) Position emblem properly on body (Fig. 10).
- (3) Press emblem firmly to body with palm of hand.
- (4) If temperature is below 21°C (70°F) warm emblem with a heat lamp or gun to assure adhesion. Do not exceed 52°C (120°F) when heating emblem.

SIDE VIEW MIRROR

REMOVAL

- (1) Remove door trim panel.
- (2) Disengage power mirror harness connector, if equipped.
- (3) Remove mirror flag seal.
- (4) Remove nuts attaching mirror to door (Fig. 11).
- (5) Separate mirror from door.

INSTALLATION

- (1) Position mirror on door. Verify that gasket seal is properly positioned.
- (2) Install nuts attaching mirror to door.
- (3) Install mirror retaining nuts.
- (4) Install mirror flag seal.
- (5) Engage power mirror harness connector, if equipped.
- (6) Install door trim panel.

SIDE VIEW MIRROR GLASS

REMOVAL

- (1) With damaged mirror still on vehicle, position mirror glass down and centered.
- (2) Position a wide leverage device between the bottom edge of the glass and the mirror shell.
- (3) Firmly apply pressure in an upward direction until glass assembly disengages from adapter plate.
- (4) Disconnect the heater wire terminal, if equipped, or the EC plug, if equipped.

INSTALLATION

- (1) Connect the heater wire terminal or the EC plug, if equipped.
- (2) Position the replacement glass in the mirror shell and align the four snap tabs with the four cavities in the shell.
- (3) Apply firm pressure inward until the replacement glass assembly engages with the adapter plate. Correct assembly will result in a firm click. Glass assembly should exhibit even gaps to the shell when complete.
- (4) Pull lightly on corners of glass assembly to ensure all four snaps are engaged and there is no free play.

REMOVAL AND INSTALLATION (Continued)

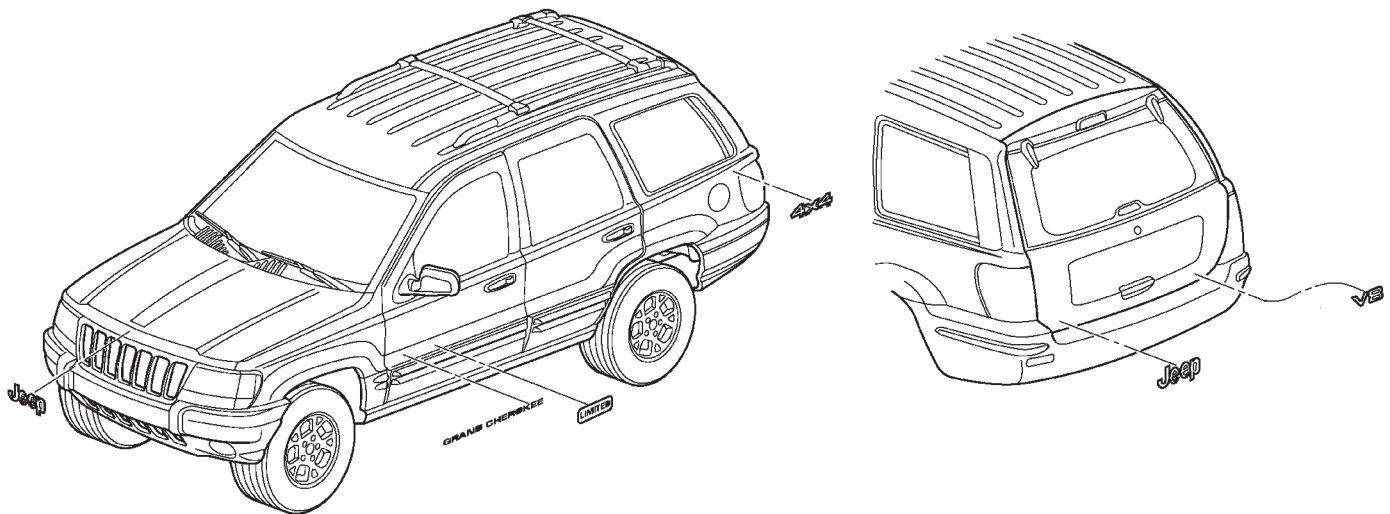

80b34e9b

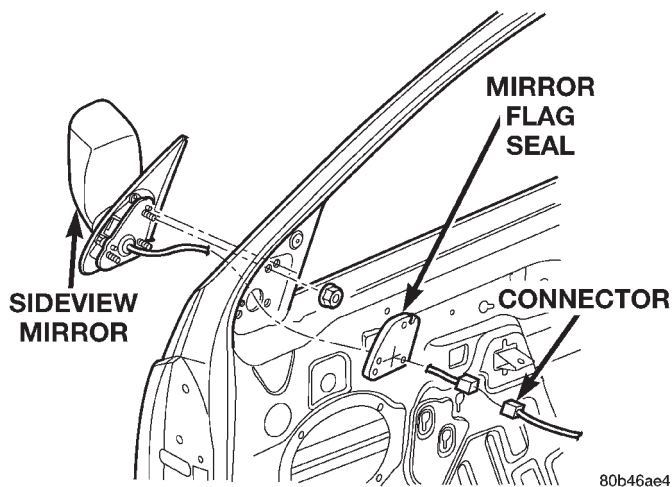
Fig. 10 Exterior Nameplates

80b46ae4

Fig. 11 Side View Mirror**FRONT FENDER****REMOVAL**

- (1) Using a wax crayon or equivalent, mark position of fender.
- (2) Remove front fender liner.
- (3) Pull back fascia and remove screws attaching fender to fascia.
- (4) Remove screws attaching lower fender bracket located behind fascia.
- (5) Remove screws attaching fender to rocker panel (Fig. 12).
- (6) Remove screws attaching rear of fender to A-pillar brackets.
- (7) Open hood.

- (8) Loosen screw under hood hinge, attaching fender to engine compartment rail .
- (9) Remove screws attaching fender to engine compartment rail (Fig. 13).
- (10) Right fender only:
 - (a) If equipped, remove radio antenna.
- (11) Separate fender from body.

INSTALLATION

- (1) Position fender on body.
- (2) Right fender only:
 - (a) If equipped, install radio antenna.
- (3) Install all screws finger-tight.
- (4) Align fender with adjacent body panels and wax crayon reference marks.
- (5) Tighten all screws.
- (6) Install inner fender liner.

FRONT DOOR TRIM PANEL**REMOVAL**

- (1) Remove trim plug from mirror flag bezel.
- (2) Remove screws attaching trim panel to door (Fig. 14).
- (3) Using trim remover (C-4829 or equivalent), detach trim panel perimeter push-in fasteners from door inner panel.
- (4) Lift trim panel upward and separate from door.
- (5) If equipped, disconnect harness connectors for power accessories.
- (6) Disconnect latch rods from inside handle actuator.
- (7) Separate trim panel from vehicle.

REMOVAL AND INSTALLATION (Continued)

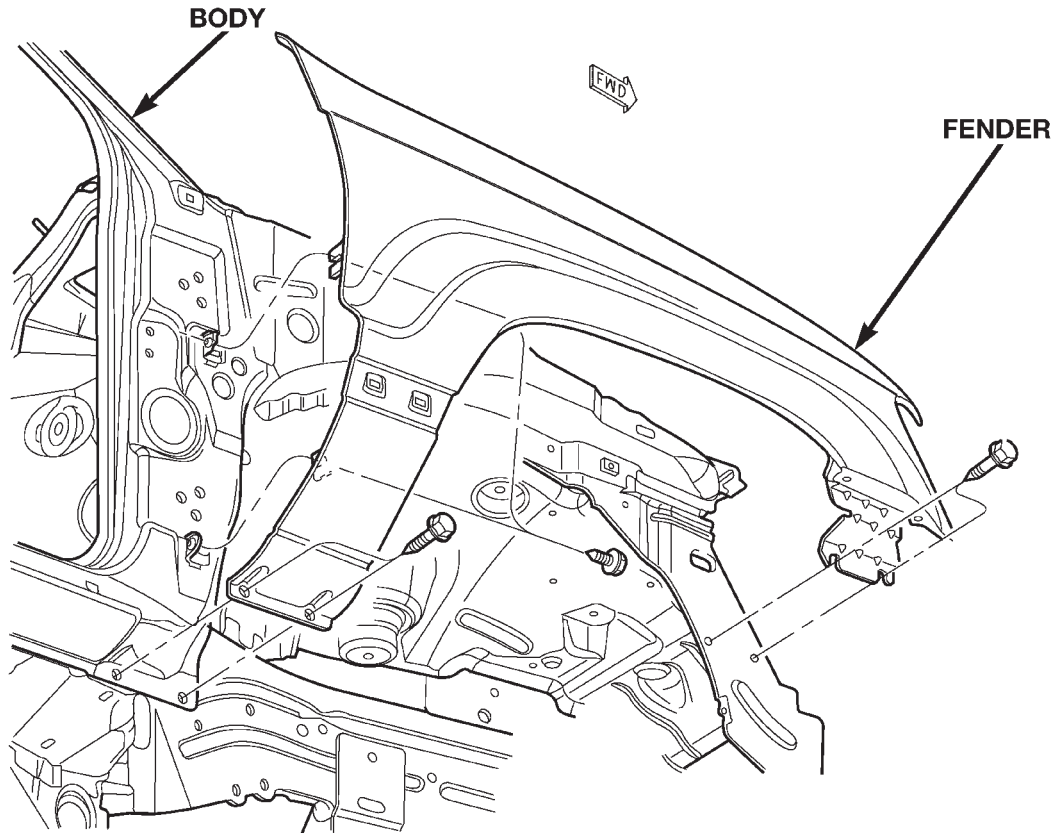

80b34e99

Fig. 12 Fender Mounting

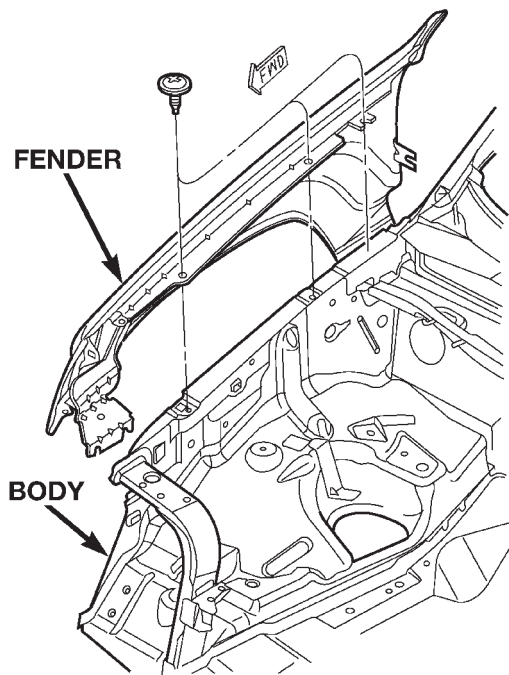

80b3c70d

Fig. 13 Upper Fender Mounting

INSTALLATION

- (1) Connect latch rods to inside handle actuator.

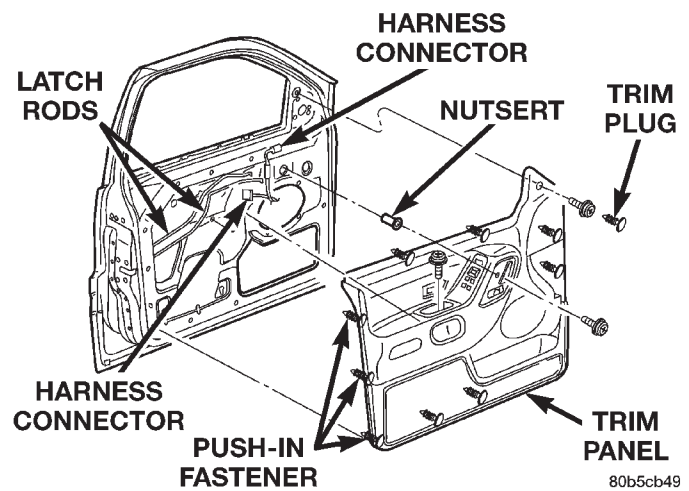

80b5cb49

Fig. 14 Front Door Trim Panel

- (2) If equipped, connect harness connectors to power accessories.
- (3) Position trim panel on door inner panel.
- (4) Press trim panel push-in fasteners inward around perimeter of door.
- (5) Install screws attaching trim panel to door.
- (6) Install trim plug in mirror flag bezel.

REMOVAL AND INSTALLATION (Continued)

FRONT DOOR WATERDAM

REMOVAL

- (1) Remove door trim panel.
- (2) Peel the waterdam from door.
- (3) Route all harnesses and linkage rods through waterdam as necessary.
- (4) Separate waterdam from door (Fig. 15).

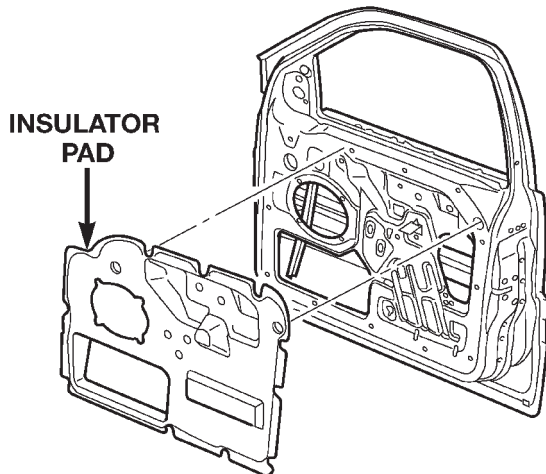

80b46b2f

Fig. 15 Front Door Waterdam

INSTALLATION

- (1) Waterdam contact surface must be free of contaminants. Clean as necessary.
- (2) Route all harnesses and linkage rods through waterdam as necessary.
- (3) Position waterdam on door and align all holes.
- (4) Press waterdam on door.
- (5) Install door trim panel.

FRONT DOOR CHECK

REMOVAL

- (1) Remove trim panel.
- (2) Remove waterdam.
- (3) Remove speaker.
- (4) Remove screws attaching door check to A-pillar.
- (5) Remove nuts attaching door check to door (Fig. 16).
- (6) Remove door check through speaker location hole.

INSTALLATION

- (1) Position door check on door through speaker location hole.
- (2) Install nuts attaching door check to door.
- (3) Install screws attaching door check to A-pillar.
- (4) Install speaker.
- (5) Install waterdam.
- (6) Install trim panel.

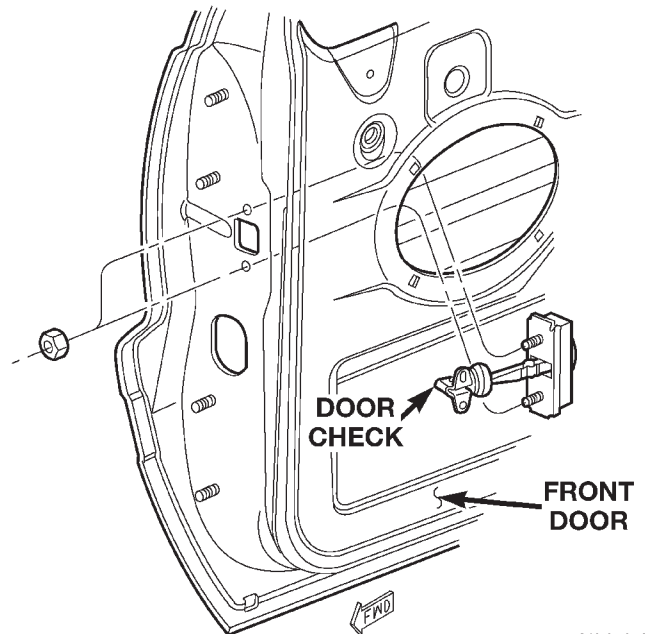

80b3c6ef

Fig. 16 Door Check

FRONT DOOR

REMOVAL

- (1) Disconnect front door harness connector (Fig. 17).
- (2) Support door with padded floor jack.
- (3) Remove retaining clips from hinge pins.
- (4) Tap out hinge pins.
- (5) Separate door from vehicle.

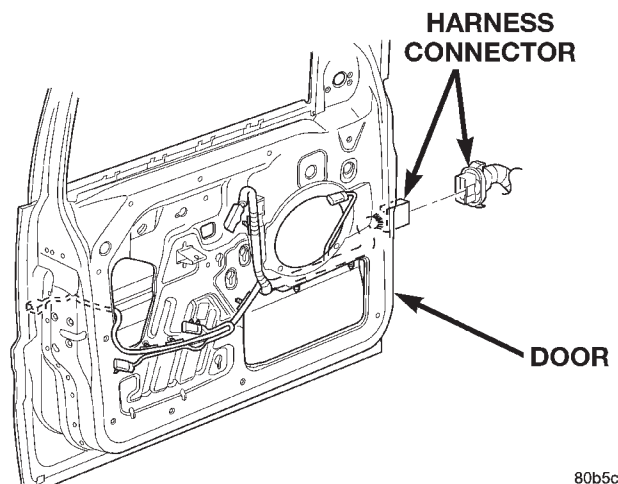

80b5cb4b

Fig. 17 Front Door Harness Connector

INSTALLATION

- (1) Position door at vehicle and align hinges.
- (2) Install hinge pins.
- (3) Install retaining clips for hinge pins.
- (4) Connect front door harness connector.

REMOVAL AND INSTALLATION (Continued)

FRONT DOOR HINGE

REMOVAL

- (1) Open and support door.
- (2) Using a wax pencil, or other suitable device, reference mark the hinge placement
- (3) Disconnect the door wire harness.
- (4) Remove the door check from the "A" pillar (Fig. 18).
- (5) Remove the fasteners retaining the door hinge to the door (Fig. 19).
- (6) Remove the door.
- (7) Remove the hinge from the "A" pillar.

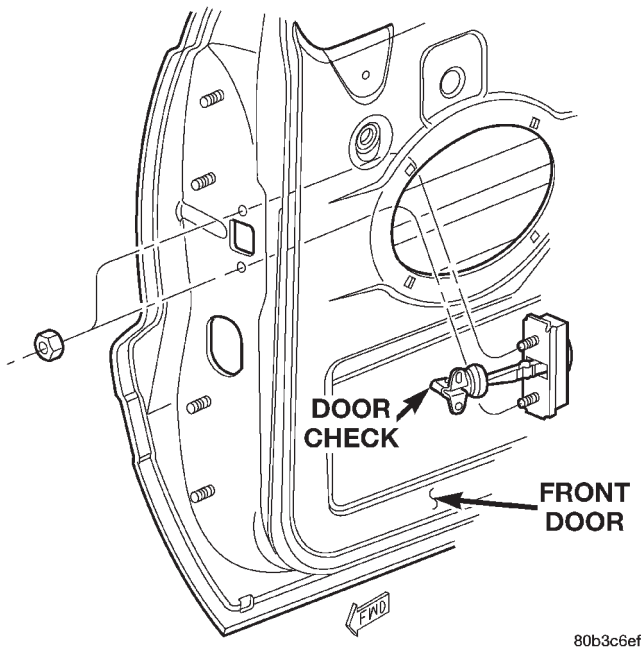

Fig. 18 Front Door Check

INSTALLATION

- (1) Position hinge on "A" pillar. (Use 3M™ Fast and Firm or equivalent on the hinge to body mating surface as a sealant.)
- (2) Install hinge to body bolts, but do not tighten.
- (3) Align the hinge to the reference marks and torque the bolts to 35N·m (26 ft. lbs.).
- (4) Install the door on the hinge and align with the reference marks.
- (5) Tighten the door to hinge fasteners.
- (6) For adjustment see door adjustment procedure.

FRONT DOOR OUTSIDE HANDLE

REMOVAL

- (1) Remove door trim panel and waterdam.
- (2) Locate glass to full up position.
- (3) Remove glass run channel.
- (4) Disconnect lock cylinder to latch rod.

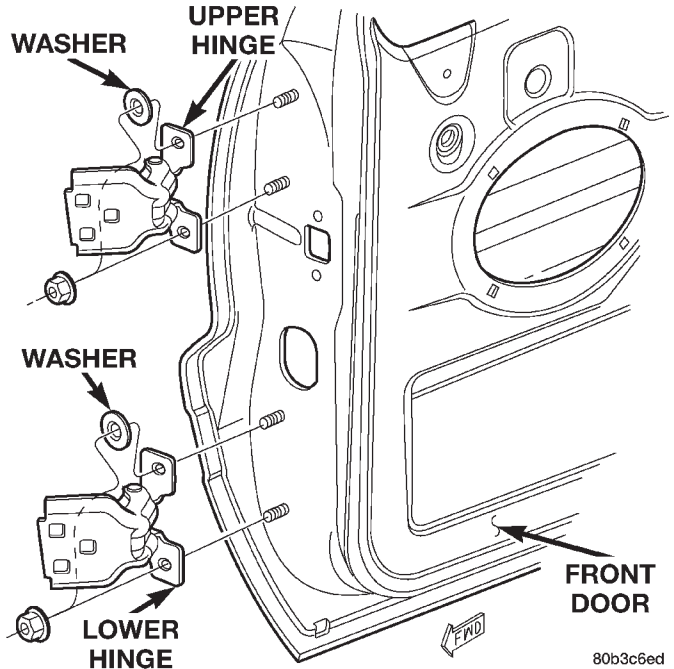

Fig. 19 Front Door Hinges

- (5) Disconnect outside handle to latch rod
- (6) Remove fasteners attaching outside handle to door (Fig. 20).
- (7) Remove outside handle from door.
- (8) Disconnect anti-theft harness connector, if equipped.
- (9) Separate outside handle from vehicle.

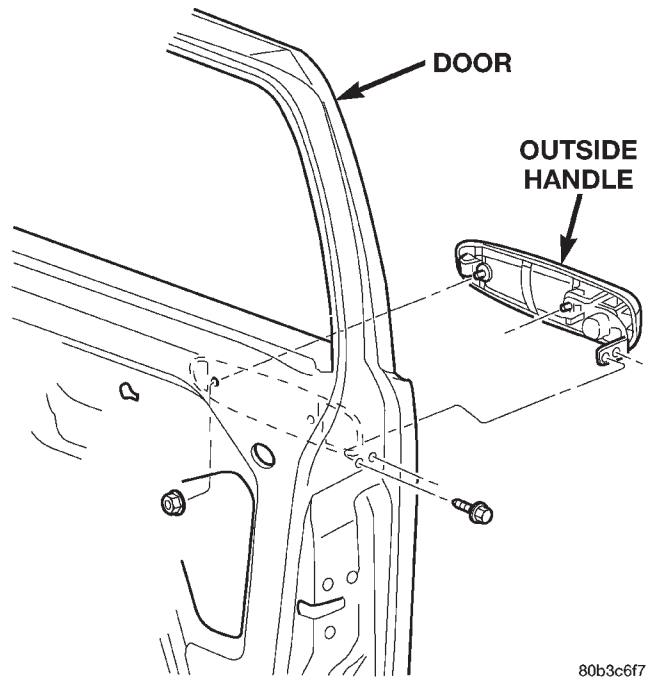

Fig. 20 Front Door Outside Handle

INSTALLATION

- (1) Position outside handle at door.

REMOVAL AND INSTALLATION (Continued)

- (2) Connect anti-theft harness connector, if equipped.
- (3) Position outside handle in door.
- (4) Install fasteners attaching outside handle to door.
- (5) Connect outside handle to latch rod
- (6) Connect lock cylinder to latch rod.
- (7) Install glass run channel.
- (8) Locate glass to full down position.
- (9) Install waterdam and door trim panel.

FRONT DOOR LOCK CYLINDER

REMOVAL

- (1) Remove door trim panel and insulator.
- (2) Remove outside door handle.
- (3) Remove screw securing lock cylinder retainer to outside door handle (Fig. 21).
- (4) Separate lock cylinder from door handle.
- (5) Disconnect lock cylinder switch, if equipped.

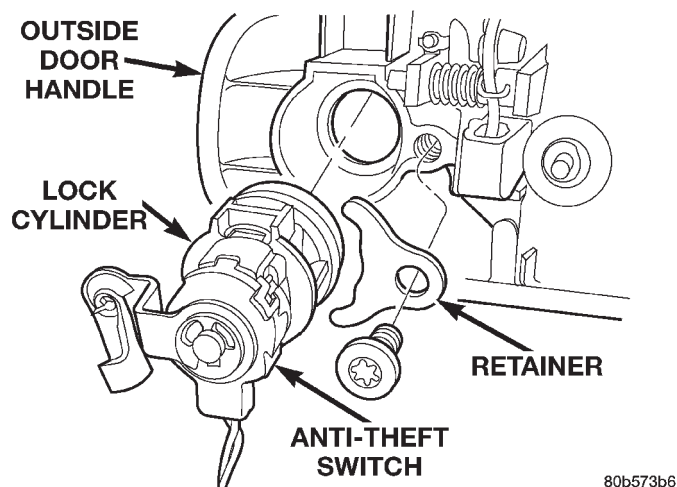

Fig. 21 Front Door Lock Cylinder

INSTALLATION

- (1) Connect lock cylinder switch, if equipped.
- (2) Position lock cylinder in door handle.
- (3) Position lock cylinder retainer and install screw.
- (4) Install outside door handle.
- (5) Install insulator and trim panel.

FRONT DOOR LATCH

REMOVAL

- (1) Locate glass in full up position.
- (2) Remove door trim panel and isolator.
- (3) Remove glass run channel.
- (4) Remove screws attaching door latch to door (Fig. 22).
- (5) Disconnect all rods from door latch.
- (6) Disconnect wire harness connector, if equipped.

- (7) Separate door latch from door.

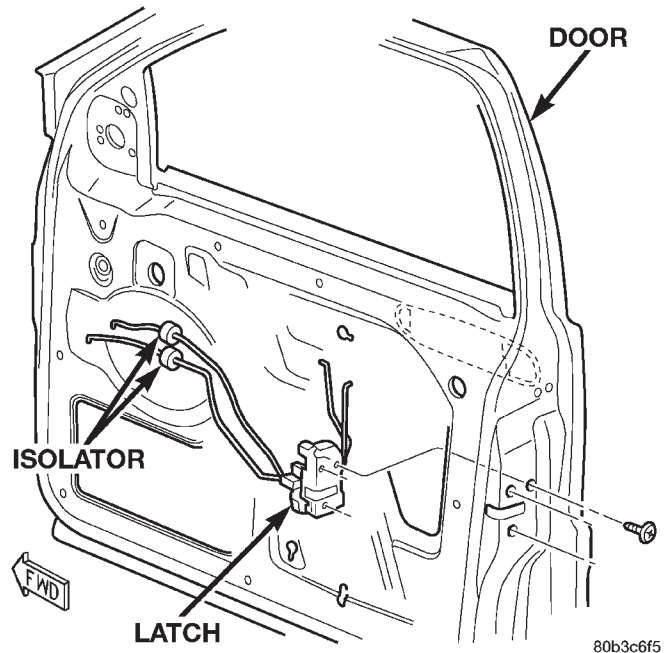

Fig. 22 Door Latch

INSTALLATION

- (1) Position door latch at door.
- (2) Connect wire harness connector, if equipped.
- (3) Connect all rods to door latch.
- (4) Install screws attaching door latch to door. Tighten screws to 10 N·m (7 ft. lbs.) torque.
- (5) Install glass run channel.
- (6) Install isolator and door trim panel.

FRONT DOOR LATCH STRIKER

REMOVAL

- (1) Remove screws attaching striker to B-pillar.
- (2) Separate striker and spacer from B-pillar (Fig. 23).

INSTALLATION

- (1) Position striker and spacer on B-pillar.
- (2) Install screws attaching striker to B-pillar. Tighten screws to 28 N·m (20 ft. lbs.) torque.

FRONT DOOR INSIDE HANDLE ACTUATOR

REMOVAL

- (1) Remove door trim panel.
- (2) Disconnect latch and lock rods from inside handle actuator.
- (3) Remove screws attaching inside handle actuator to trim panel (Fig. 24).
- (4) Separate inside handle actuator from trim panel.

REMOVAL AND INSTALLATION (Continued)

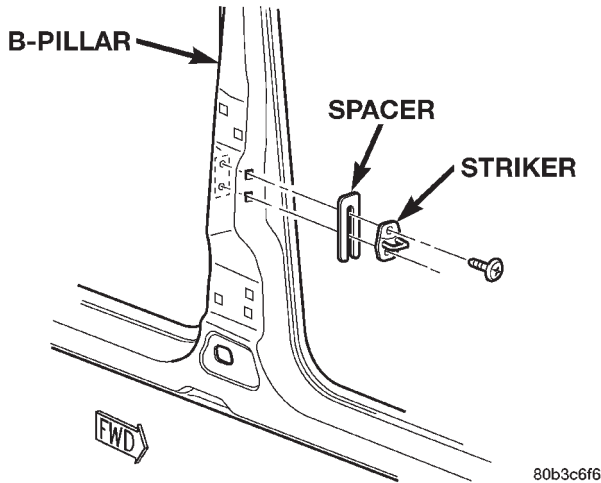

Fig. 23 Front Door Latch Striker

80b3c6f6

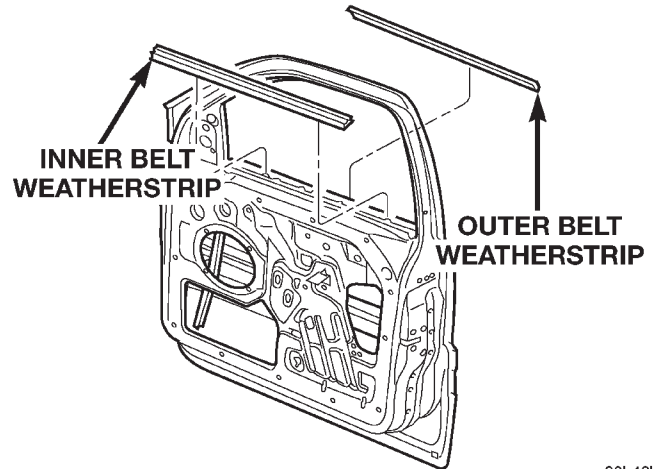

Fig. 25 Inner/Outer Belt Weather Strip

80b46b2d

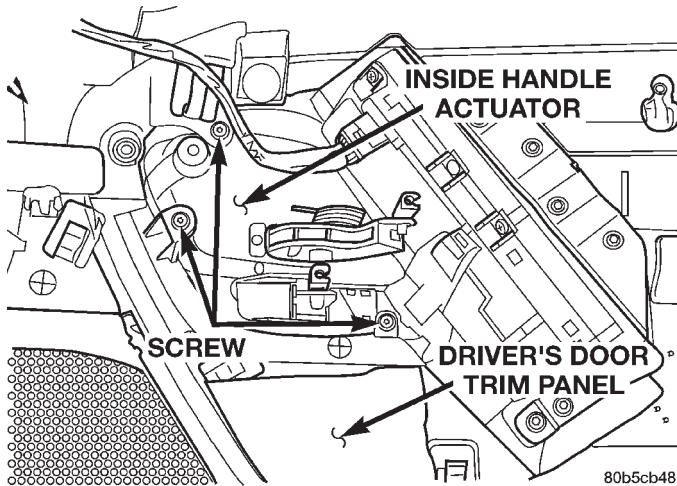

Fig. 24 Front Door Inside Handle Actuator

80b5cb48

INSTALLATION

- (1) Position inside handle actuator in trim panel.
- (2) Install screws attaching inside handle actuator to trim panel.
- (3) Connect latch and lock rods to inside handle actuator.
- (4) Install door trim panel.

FRONT DOOR INNER BELT SEAL

REMOVAL

- (1) Remove door trim panel.
- (2) Using a trim stick or other suitable device, carefully pry up inner edge of seal (Fig. 25).
- (3) Grasp the edge of the seal and pull upward to remove seal from door flange.

INSTALLATION

- (1) Position the seal on the door flange.
- (2) Firmly press downward to seat seal on the door flange.

- (3) Install the door trim panel.

FRONT DOOR OUTER BELT SEAL

REMOVAL

- (1) Lower the door glass.
- (2) Remove the screw from the inner door panel attaching the seal to outer door panel (Fig. 25).
- (3) Pull the seal rearward to release from the side view mirror bezel.
- (4) Lift seal and separate from door panel.

INSTALLATION

- (1) Position seal on the door panel.
- (2) Push the seal forward to install under the side view mirror bezel.
- (3) Install the screw from the inner door panel attaching the seal to outer door panel.
- (4) Raise the door glass.

FRONT DOOR GLASS RUN CHANNEL WEATHERSTRIP

REMOVAL

- (1) Remove trim panel.
- (2) Remove inner belt weatherstrip.
- (3) Remove outer belt weatherstrip.
- (4) Grasp seal from upper run channel corner and firmly pull weatherstrip from flange and run channel (Fig. 26).

INSTALLATION

NOTE: Soapy water may be used to aid in installation.

- (1) Remove front door speaker.
- (2) Position weatherstrip on flange aligning each corner.

REMOVAL AND INSTALLATION (Continued)

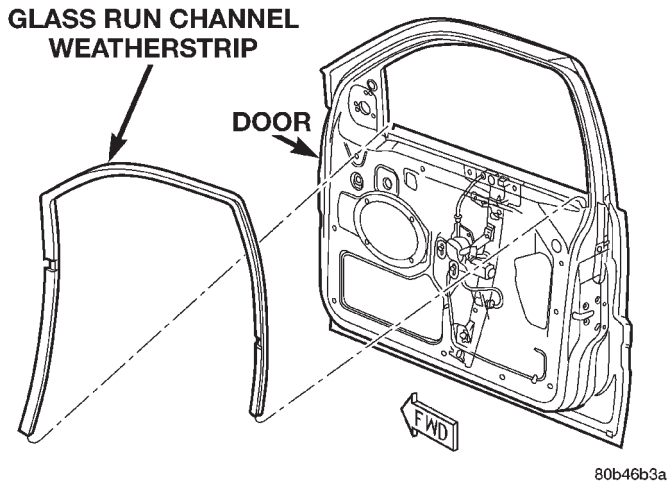

80b46b3a

Fig. 26 Front Door Glass Run Channel Weatherstrip

- (3) Press weatherstrip into position.
- (4) Carefully move door glass for and aft and press weatherstrip into glass run channels.
- (5) Install front door speaker.
- (6) Install outer belt weatherstrip.
- (7) Install inner belt weatherstrip.
- (8) Install trim panel.

FRONT DOOR GLASS RUN CHANNEL**REMOVAL**

NOTE: Only the rearward glass run channel is serviceable.

- (1) Remove door trim panel.
- (2) Remove isolator.
- (3) Remove inner and outer belt weatherstrip.
- (4) Remove bolt attaching run channel to inner door panel (Fig. 27).
- (5) Peel back glass run channel weatherstrip on rear run channel.
- (6) Pull glass run channel downward to separate from door.
- (7) Remove glass run channel from door.

INSTALLATION

- (1) Position glass run channel in door.
- (2) Align glass run channel with door frame run channel and slide channel upward to secure door.
- (3) Press glass run channel weatherstrip into rear run channel.
- (4) Install bolt attaching run channel to inner door panel.
- (5) Install inner and outer belt weatherstrip.
- (6) Install isolator.
- (7) Install door trim panel.

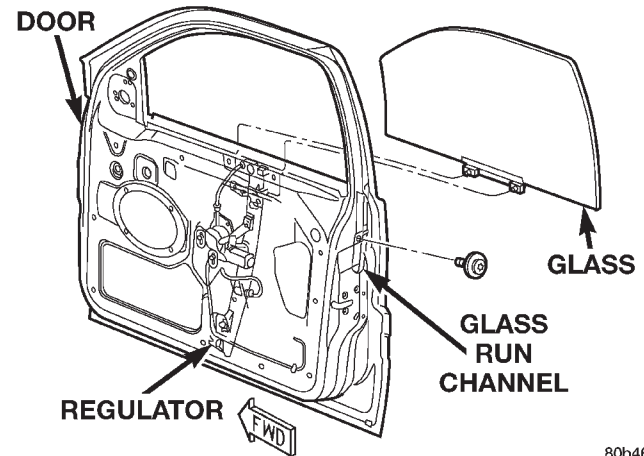

80b46b3b

Fig. 27**FRONT DOOR OPENING WEATHERSTRIP****REMOVAL**

- (1) Remove A-pillar trim.
- (2) Remove B-pillar upper trim.
- (3) Remove B-pillar lower trim.
- (4) Pull weatherstrip from door opening flange.

INSTALLATION

- (1) Position weatherstrip at corners.
- (2) Move upward and around edge of door opening seating weatherstrip onto flange (Fig. 28).
- (3) Engage connector plug with each end of weatherstrip at bottom of door opening.
- (4) Install B-pillar lower trim.
- (5) Install B-pillar upper trim.
- (6) Install A-pillar trim.

FRONT DOOR SECONDARY WEATHERSTRIP**REMOVAL**

The front door secondary weatherstrip is attached to the door shutface with push-in fasteners.

- (1) Open door.
- (2) Using a trim panel removal tool, remove push-in fasteners attaching secondary weatherstrip to door shutface (Fig. 29).
- (3) Separate secondary weatherstrip from door.

INSTALLATION

- (1) Clean contact area as necessary.
- (2) Position secondary weatherstrip on door shutface.
- (3) Install push-in fasteners attaching secondary weatherstrip to door shutface.

REMOVAL AND INSTALLATION (Continued)

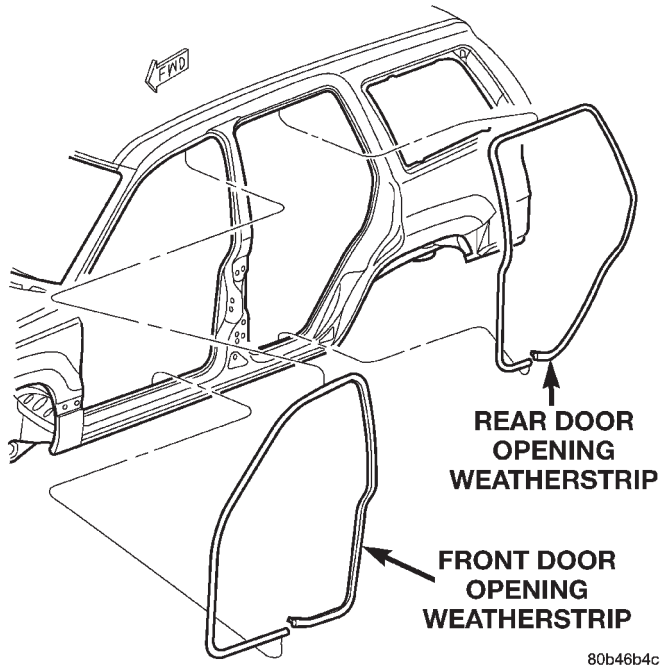

80b46b4c

Fig. 28 Door Opening Weatherstrip

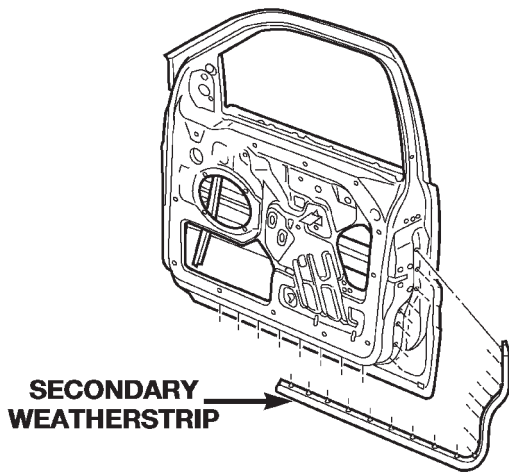

80b46b2e

Fig. 29 Front Door Secondary Weatherstrip

FRONT DOOR WINDOW REGULATOR

REMOVAL

- (1) Remove door trim panel.
- (2) Remove isolator.
- (3) Remove front door glass.
- (4) Loosen bolts attaching regulator to inner door panel (Fig. 30).
- (5) Remove bolt attaching regulator to inner door panel (Fig. 31).
- (6) Lift regulator upward to disengage bolts from door inner panel.
- (7) Disengage power window regulator harness connector, if equipped.
- (8) Remove regulator through access hole in door.

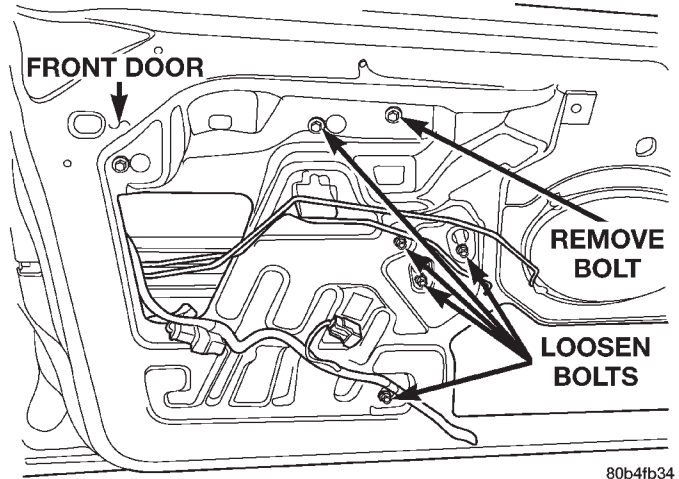

80b4fb34

Fig. 30 Front Door Regulator Bolts

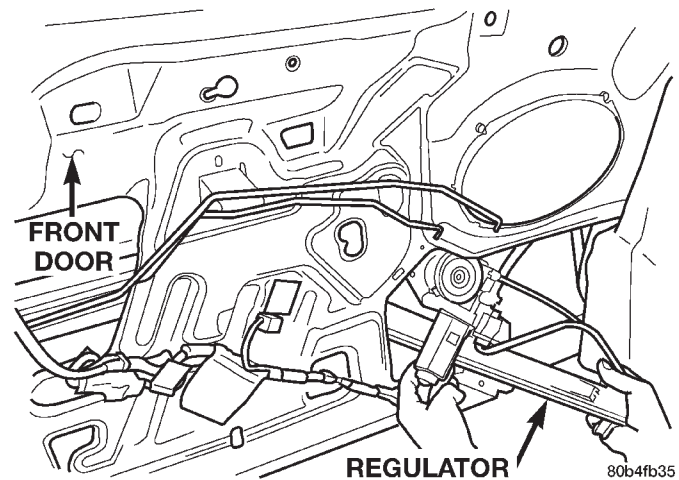

80b4fb35

Fig. 31 Front Door Window Regulator

INSTALLATION

- (1) Position regulator in door through access hole.
- (2) Engage power window regulator harness connector, if equipped.
- (3) Lift regulator upward and engage bolts in door inner panel key hole slots.
- (4) Install bolt attaching regulator to inner door panel.
- (5) Tighten bolts attaching regulator to inner door panel.
- (6) Install front door glass.
- (7) Install isolator.
- (8) Install door trim panel.

FRONT DOOR GLASS

REMOVAL

- (1) Locate glass to full down position.
- (2) Remove trim panel.
- (3) Remove inner belt weatherstrip.
- (4) Remove outer belt weatherstrip.

REMOVAL AND INSTALLATION (Continued)

- (5) Locate glass to 3/4 up position.
- (6) Remove front door insulator.
- (7) Using a long flat blade or hook type tool, disengage clips (Fig. 32) attaching glass retainer to glass lift plate.
- (8) Carefully push bottom of glass panel outward to disengage glass retainer studs from lift plate (Fig. 33).
- (9) Lift glass upward and out of door.

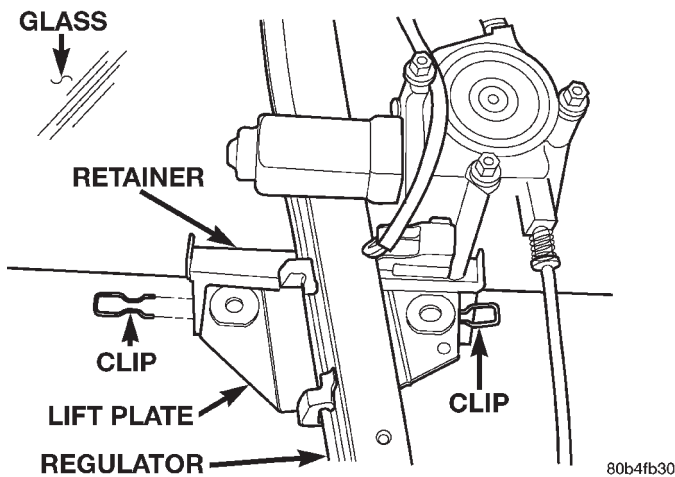

Fig. 32 Front Door Glass Clips

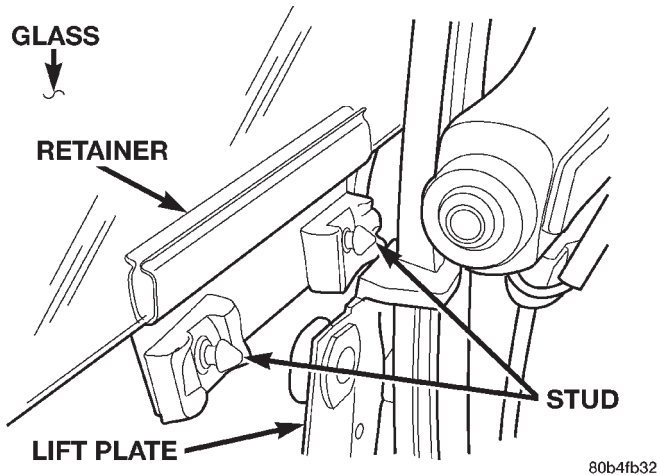

Fig. 33 Front Door Glass Retainer Studs

INSTALLATION

- (1) Lower glass into position.
- (2) Carefully align glass retainer studs with lift plate and insert studs into lift plate.
- (3) Engage clips attaching glass retainer to glass lift plate.
- (4) Install front door insulator.
- (5) Locate glass to full down position.
- (6) Install outer belt weatherstrip.
- (7) Install inner belt weatherstrip.
- (8) Install trim panel.

REAR DOOR B-PILLAR SEAL

REMOVAL

The B-pillar seal is attached to the rear door with adhesive tape.

- (1) Peel seal from the door (Fig. 34).

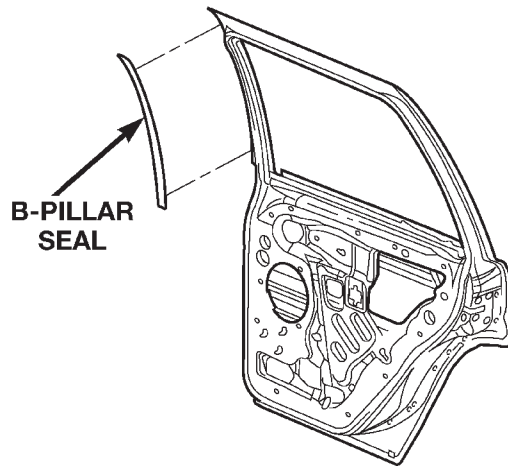

Fig. 34 B-Pillar Seal

INSTALLATION

- (1) Clean contact area with Mopar Super Kleen or equivalent.
- (2) Remove carrier from seal.
- (3) Align seal on door and press into place.

REAR DOOR TRIM PANEL

REMOVAL

- (1) Remove screws attaching trim panel to door (Fig. 35).
- (2) Using trim remover (C-4829 or equivalent), detach trim panel perimeter push-in fasteners from door inner panel.
- (3) Lift trim panel upward and separate from door.
- (4) If equipped, disconnect harness connectors for power accessories.
- (5) Disconnect latch rods from inside handle actuator.
- (6) Separate trim panel from vehicle.

INSTALLATION

- (1) Connect latch rods to inside handle actuator.
- (2) If equipped, connect harness connectors to power accessories.
- (3) Position trim panel on door inner panel.
- (4) Press trim panel push-in fasteners inward around perimeter of door.
- (5) Install screws attaching trim panel to door.

REMOVAL AND INSTALLATION (Continued)

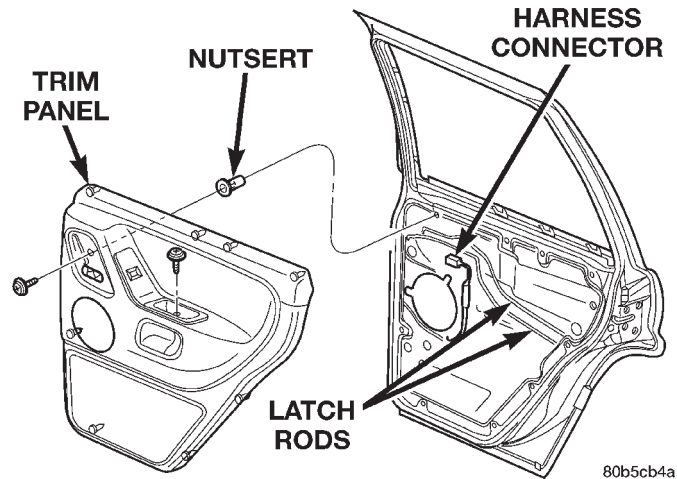

Fig. 35 Rear Door Trim Panel

REAR DOOR WATERDAM

REMOVAL

- (1) Remove door trim panel.
- (2) Peel the waterdam from door.
- (3) Route all harnesses and linkage rods through waterdam as necessary.
- (4) Separate waterdam from door (Fig. 36).

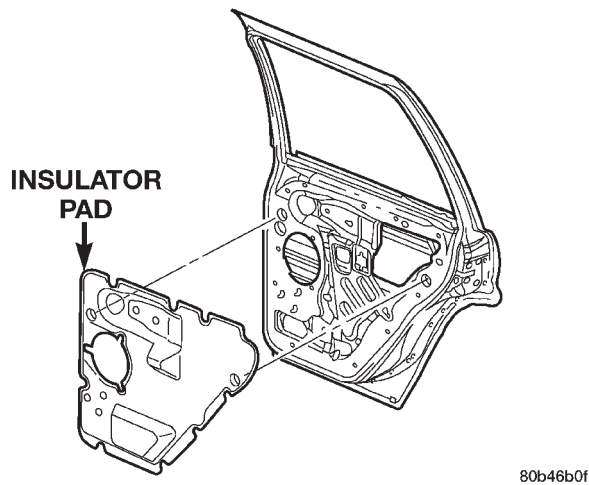

Fig. 36 Rear Door Waterdam

INSTALLATION

- (1) Waterdam contact surface must be free of contaminants. Clean as necessary.
- (2) Route all harnesses and linkage rods through waterdam as necessary.
- (3) Position waterdam on door and align all holes.
- (4) Press waterdam on door.
- (5) Install door trim panel.

REAR DOOR CHECK

REMOVAL

- (1) Remove trim panel.
- (2) Remove waterdam.
- (3) Remove speaker.
- (4) Remove screws attaching door check to B-pillar.
- (5) Remove nuts attaching door check to door (Fig. 37).
- (6) Remove door check through speaker location hole.

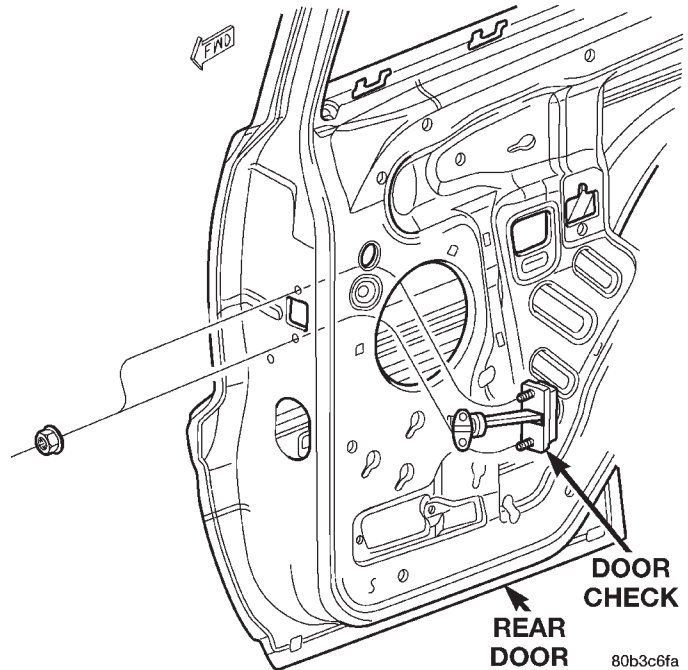

Fig. 37 Door Check

INSTALLATION

- (1) Position door check on door through speaker location hole.
- (2) Install nuts attaching door check to door.
- (3) Install screws attaching door check to B-pillar.
- (4) Install speaker.
- (5) Install waterdam.
- (6) Install trim panel.

REAR DOOR

REMOVAL

- (1) Disconnect rear door harness connector (Fig. 38).
- (2) Support door with padded floor jack.
- (3) Remove retaining clips from hinge pins.
- (4) Tap out hinge pins.
- (5) Separate door from vehicle.

REMOVAL AND INSTALLATION (Continued)

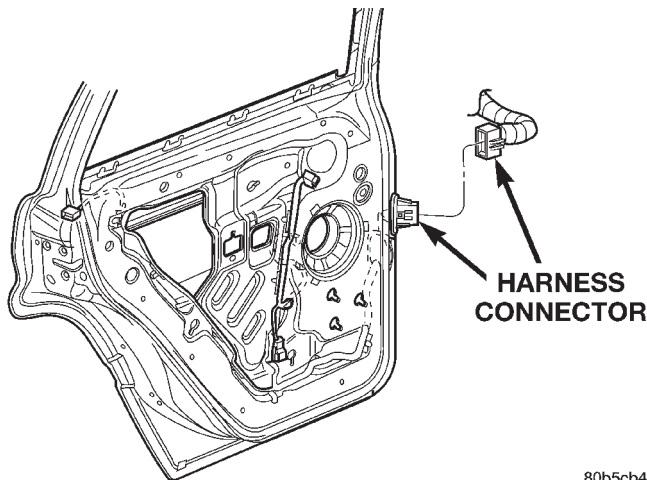

Fig. 38 Rear Door Harness Connector

80b5cb4c

INSTALLATION

- (1) Position door at vehicle and align hinges.
- (2) Install hinge pins.
- (3) Install retaining clips for hinge pins.
- (4) Connect rear door harness connector.

REAR DOOR HINGE**REMOVAL**

- (1) Open front door and rear door.
- (2) Reference mark hinges for installation (Fig. 39).
- (3) Support rear door for removal of hinges.
- (4) Remove B pillar trim.
- (5) Remove nuts holding door to hinge.
- (6) Remove door.
- (7) Remove bolts holding hinge to B pillar.

INSTALLATION

- (1) Install hinge on B pillar and align reference marks.
- (2) Install bolts holding hinge to B pillar. Tighten bolts to 35N·m (23 ft. lbs.).
- (3) Install door on hinge and align reference marks. Install bolts and tighten to 35N·m (26 ft. lbs.).
- (4) Check door for fit and ease of operation. Adjust as necessary. See adjustment section.
- (5) Install B pillar trim.

REAR DOOR OUTSIDE HANDLE**REMOVAL**

- (1) Remove door trim panel and waterdam.
- (2) Locate glass to full up position.
- (3) Disconnect lock knob to latch rod.
- (4) Disconnect outside handle to latch rod.
- (5) Remove fasteners attaching outside handle to door (Fig. 40).

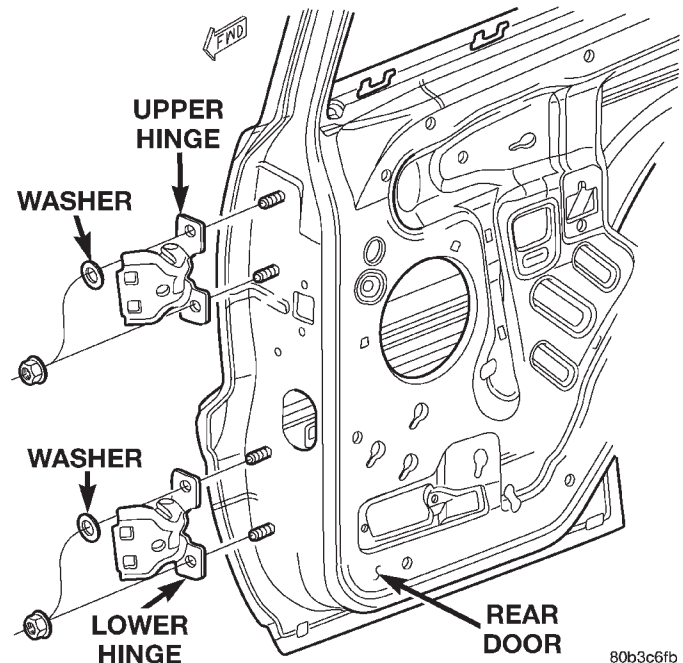
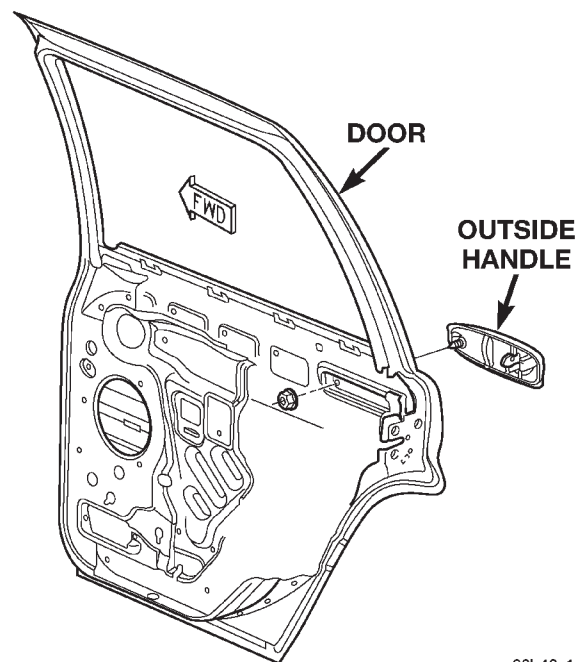

Fig. 39 Rear Door Hinge

80b3c6fb

- (6) Remove outside handle from door.
- (7) Separate outside handle from vehicle.



80b46a1c

Fig. 40 Front Door Outside Handle

INSTALLATION

- (1) Position outside handle at door.
- (2) Position outside handle in door.
- (3) Install fasteners attaching outside handle to door.
- (4) Connect outside handle to latch rod.
- (5) Connect lock knob to latch rod.

REMOVAL AND INSTALLATION (Continued)

- (6) Locate glass to full down position.
- (7) Install waterdam and door trim panel.

REAR DOOR LATCH

REMOVAL

- (1) Remove door trim panel and waterdam.
- (2) Remove screws attaching latch to door (Fig. 41).
- (3) Disconnect rods from door latch.
- (4) Separate door latch from door.

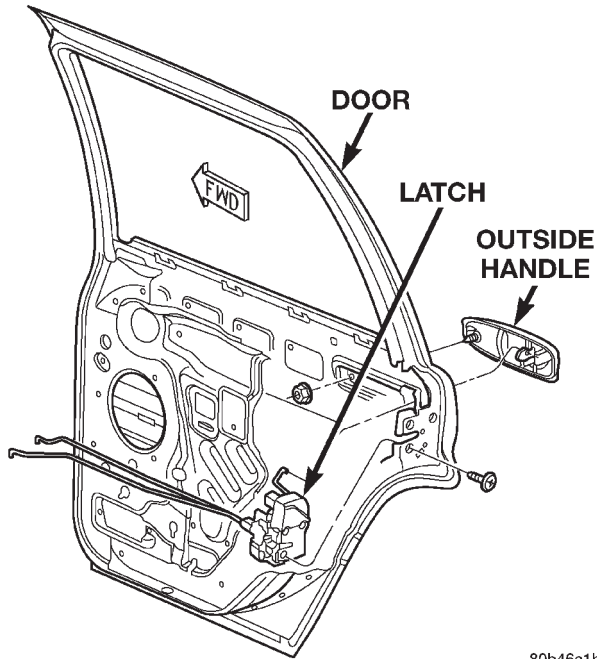

80b46a1b

Fig. 41 Rear Door Latch

INSTALLATION

- (1) position latch in door.
- (2) Connect rods to door latch.
- (3) Install screws attaching latch to door. Tighten screws to 10 N·m (95 in. lbs.) torque.
- (4) Install waterdam and door trim panel.

REAR DOOR LATCH STRIKER

REMOVAL

- (1) Open door.
- (2) Remove screws attaching striker to C-pillar (Fig. 42).
- (3) Separate striker and spacer from vehicle.

INSTALLATION

- (1) Position striker and spacer on C-pillar.
- (2) Install screws. Tighten to 28 N·m (250 in. lbs.) torque.

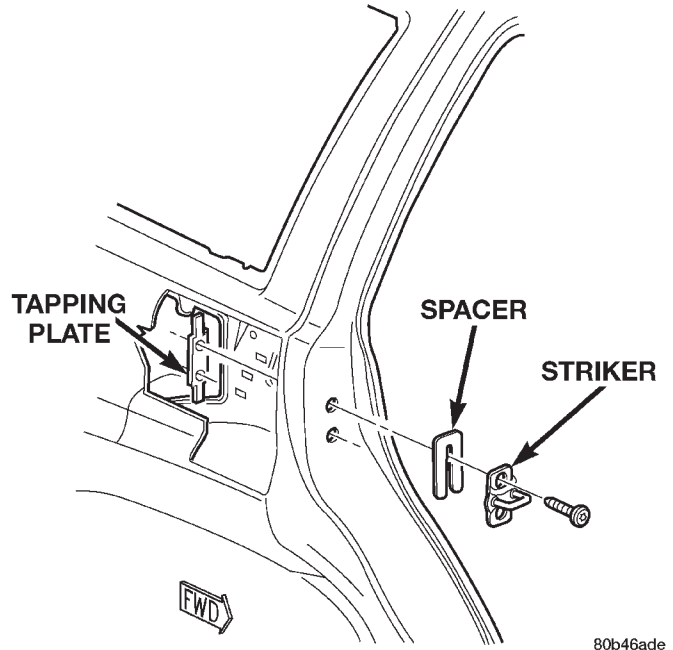

80b46ade

Fig. 42 Rear Door Latch Striker

REAR DOOR INSIDE HANDLE ACTUATOR

REMOVAL

- (1) Remove door trim panel.
- (2) Disconnect latch and lock rods from inside handle actuator.
- (3) Remove screws attaching inside handle actuator to trim panel (Fig. 43).
- (4) Separate inside handle actuator from trim panel.

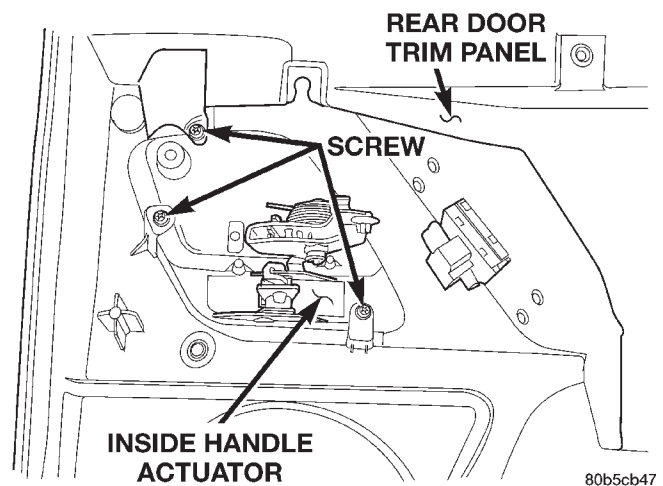

80b5cb47

Fig. 43 Rear Door Inside Handle Actuator

INSTALLATION

- (1) Position inside handle actuator in trim panel.
- (2) Install screws attaching inside handle actuator to trim panel.

REMOVAL AND INSTALLATION (Continued)

- (3) Connect latch and lock rods to inside handle actuator.
- (4) Install door trim panel.

REAR DOOR INNER BELT WEATHERSTRIP**REMOVAL**

- (1) Remove door trim panel.
- (2) Using a trim stick, carefully pry rear inner edge of inner belt weatherstrip upward.
- (3) Grasp weatherstrip and pull upward to separate from door flange (Fig. 44).

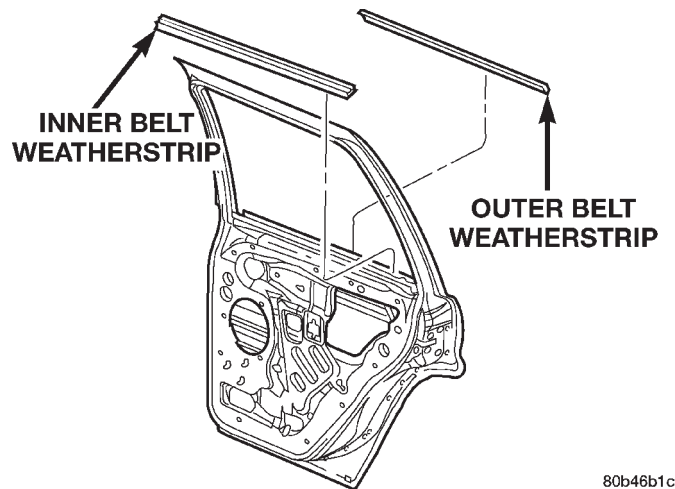
**Fig. 44 Rear Door Inner/Outer Belt Weatherstrip****INSTALLATION**

- (1) Position weatherstrip on door flange.
- (2) Firmly press downward to seat weatherstrip on flange.
- (3) Install trim panel.

REAR DOOR OUTER BELT WEATHERSTRIP**REMOVAL**

- (1) Remove trim panel.
- (2) Using a small flat blade, disengage tangs attaching outer belt weatherstrip to inner door panel.
- (3) Lift weatherstrip upward and separate from door (Fig. 44).

INSTALLATION

- (1) Position the weatherstrip onto the door flange.
- (2) Force the weatherstrip onto door flange and engage tangs. Continue rearward until it is seated on flange.
- (3) Install trim panel.

REAR DOOR OPENING WEATHERSTRIP**REMOVAL**

- (1) Remove C-pillar trim.
- (2) Remove B-pillar upper trim.
- (3) Remove B-pillar lower trim.
- (4) Remove screws at front of quarter trim panel.
- (5) Pull weatherstrip from door opening flange.

INSTALLATION

- (1) Position weatherstrip at corners.
- (2) Move upward and around edge of door opening seating weatherstrip onto flange (Fig. 28).
- (3) Engage connector plug with each end of weatherstrip at bottom of door opening.
- (4) Install screws at front of quarter trim panel.
- (5) Install B-pillar lower trim.
- (6) Install B-pillar upper trim.
- (7) Install C-pillar trim.

REAR DOOR SECONDARY WEATHERSTRIP**REMOVAL**

The rear door secondary weatherstrip is attached to the door shutface with push-in fasteners.

- (1) Open door.
- (2) Using a trim panel removal tool, remove push-in fasteners attaching secondary weatherstrip to door shutface.
- (3) Separate secondary weatherstrip from door (Fig. 45).

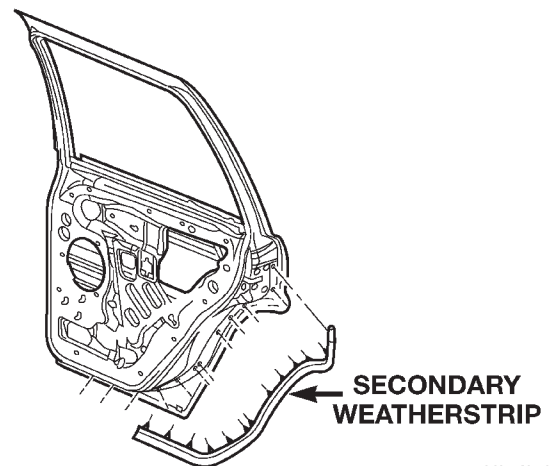
**Fig. 45 Rear Door Secondary Weatherstrip****INSTALLATION**

- (1) Clean contact area as necessary.
- (2) Position secondary weatherstrip on door shutface.
- (3) Install push-in fasteners attaching secondary weatherstrip to door shutface.

REMOVAL AND INSTALLATION (Continued)

REAR DOOR WINDOW REGULATOR

REMOVAL

- (1) Remove door trim panel and waterdam. Disconnect the speaker harness and power window harness, if equipped. If necessary, refer to removal procedure.
- (2) Lower window glass.
- (3) Pull run weatherstrip from fixed glass.
- (4) Remove fasteners retaining fixed glass module.
- (5) Remove the fixed glass module.
- (6) Raise the door glass and support.
- (7) Remove the window clips retaining regulator (Fig. 46).
- (8) Remove the door glass.
- (9) Remove the fasteners retaining the regulator (Fig. 47).
- (10) Remove the regulator.

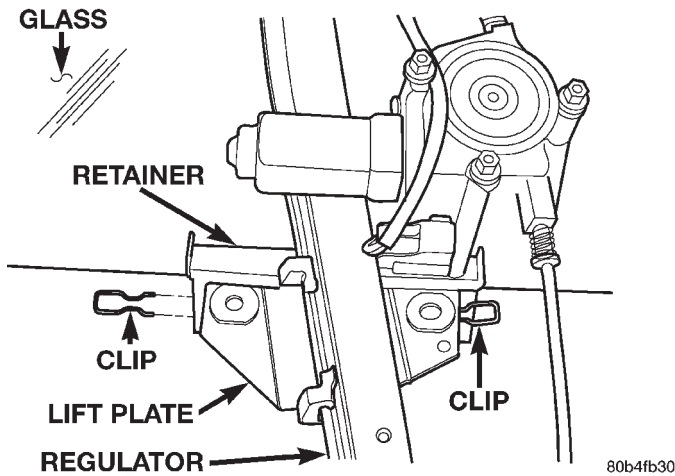

Fig. 46 Window Regulator Retainer Clips

INSTALLATION

- (1) Position the window regulator in the door.
- (2) Install the fasteners retaining the regulator.
- (3) Install the door glass.
- (4) Install the window clips retaining regulator.
- (5) Lower the door glass.
- (6) Install the fixed glass module. Tighten the fasteners.
- (7) Install the run weatherstrip.
- (8) Install the waterdam, door panel, and connect the power window and speaker harness if equipped.
- (9) Cycle the glass and check for proper operation.

REAR DOOR WINDOW GLASS

REMOVAL

- (1) Lower window glass.
- (2) Remove trim panel.
- (3) Remove waterdam.
- (4) Remove inner belt weatherstrip.
- (5) Remove stationary glass.

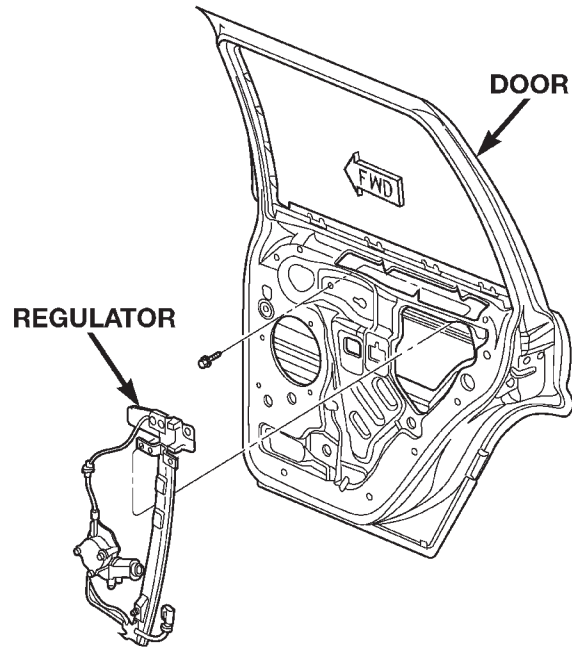

80b3c6f8

Fig. 47 Rear Door Window Regulator

- (6) Disengage clips attaching window glass to lift plate.
- (7) Press studs out of lift plate.
- (8) Lift window glass from door (Fig. 48).

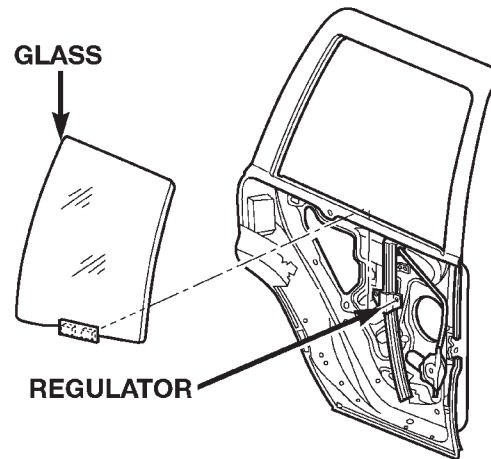

80b46b1f

Fig. 48 Glass Channel

INSTALLATION

- (1) Position window glass in door.
- (2) Engage studs into lift plate.
- (3) Engage clips attaching window glass to lift plate.
- (4) Install stationary glass.
- (5) Install inner belt weatherstrip.
- (6) Install waterdam.
- (7) Install trim panel.

REMOVAL AND INSTALLATION (Continued)

REAR DOOR STATIONARY GLASS

REMOVAL

- (1) Remove door trim panel.
- (2) Remove waterdam.
- (3) Remove inner belt weatherstrip.
- (4) Remove bolt attaching bottom of rear glass run channel to door.
- (5) Pull run channel downward and separate from door.
- (6) Remove screws attaching stationary door glass frame to door (Fig. 49) and (Fig. 50).
- (7) Separate stationary door glass from door.

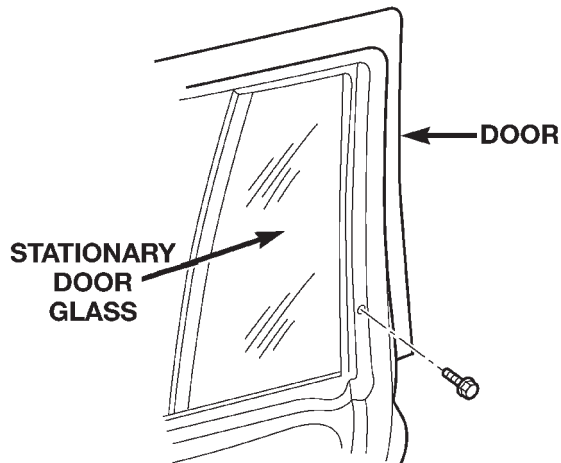

Fig. 49 Stationary Door Glass

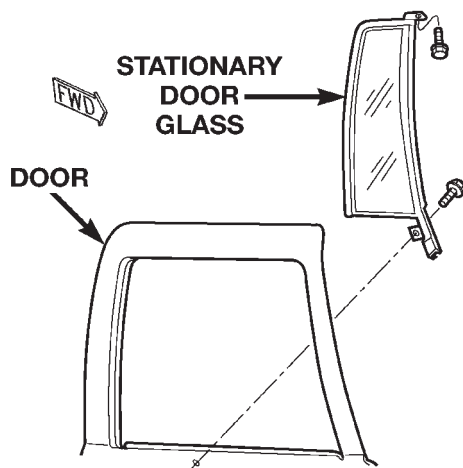

Fig. 50 Stationary Door Glass

INSTALLATION

- (1) Position stationary door glass in door.
- (2) Install screws attaching stationary door glass frame to door.
- (3) Install glass run channel.
- (4) Install inner belt weatherstrip.
- (5) Install waterdam.
- (6) Install door trim panel.

ROOF RAIL WEATHERSTRIP W/RETAINER

REMOVAL

- (1) Open front and rear doors.
- (2) Remove secondary seal from retainer to access the screws holding the retainer to the A pillar and roof panel.
- (3) Remove the screws holding the retainer in place (Fig. 51).
- (4) Remove the retainer.

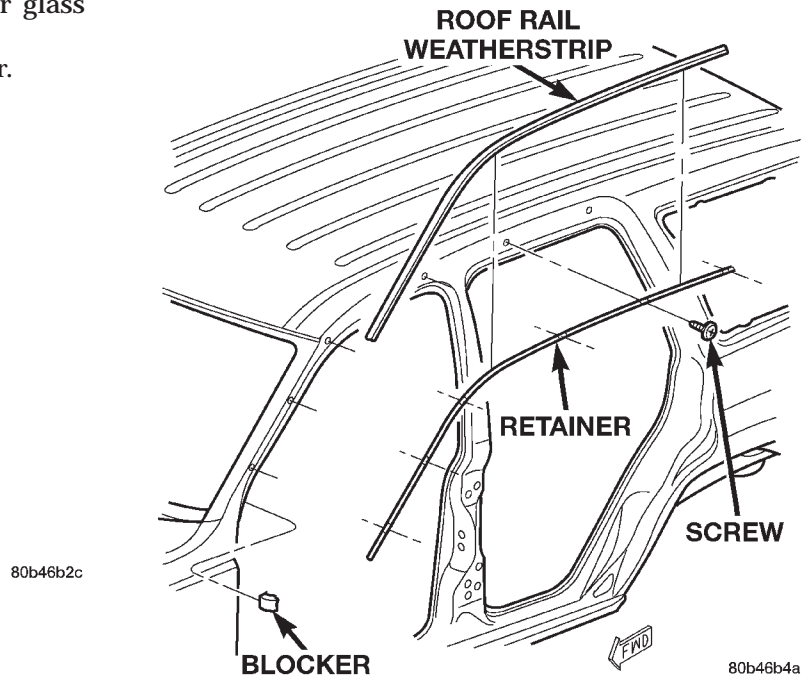

Fig. 51 Upper Body Seal With Retainer

INSTALLATION

- (1) Position the retainer on the A pillar and roof panel.
- (2) Align the screw holes and install the screws.
- (3) Install secondary seal.

FUEL FILL DOOR

REMOVAL

- (1) Open the fuel filler door.
- (2) Remove the screws attaching the door to the quarter panel (Fig. 52).
- (3) Remove the door from the panel.

INSTALLATION

- (1) Position the fuel filler door on the quarter panel with the screw holes aligned.
- (2) Install the screws attaching the fuel filler door to the quarter panel.

REMOVAL AND INSTALLATION (Continued)

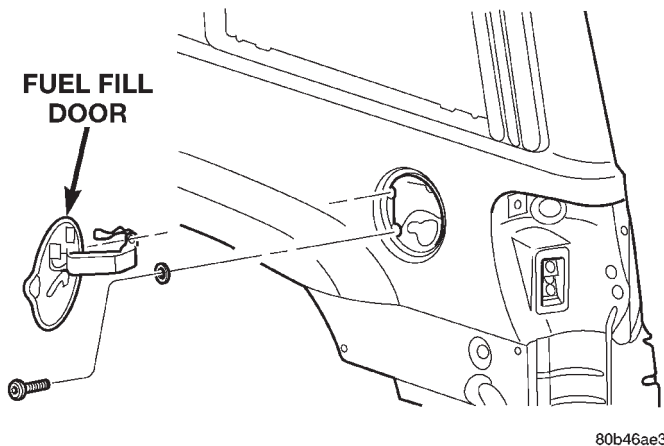

Fig. 52 Fuel Filler Door

BODY SIDE CLADDING

REMOVAL-FENDER/QUARTER PANEL

- (1) Remove the screws at wheel opening (Fig. 53).
- (2) Using a trim stick, gently pry bottom of cladding up.
- (3) Lift upwards and remove cladding.

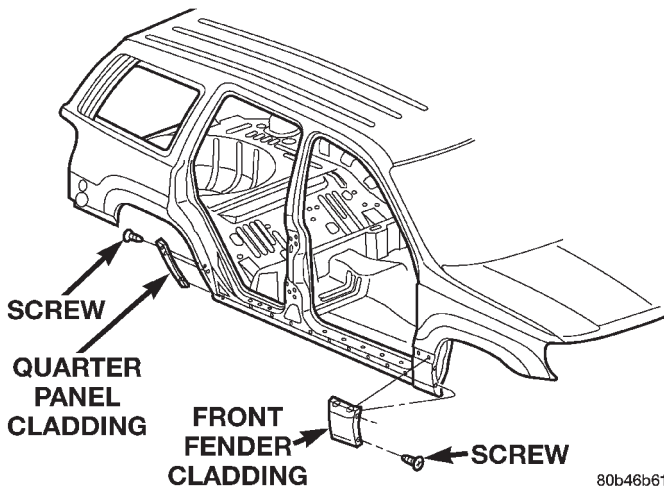

Fig. 53 Front Fender/ Quarter Panel

INSTALLATION-FENDER/QUARTER PANEL

- (1) Thoroughly clean the area with Mopar Super Kleen or equivalent.
- (2) Align the cladding with the screw holes in the fender.
- (3) Press the cladding in place.
- (4) Install the screws at the wheel opening.

REMOVAL-REAR DOOR

- (1) Open the rear door.
- (2) Using a trim stick, pry the upper rear edge off the door. Continue towards the front edge of the rear door (Fig. 54).

- (3) Using a heat gun, warm the adhesive tape on the bottom of the cladding and remove the cladding.

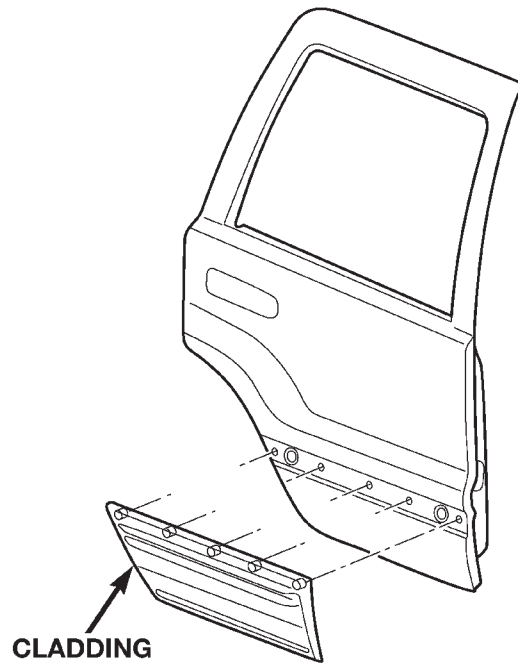

Fig. 54 Rear Door Cladding

INSTALLATION-REAR DOOR

- (1) Clean the area thoroughly with Mopar Super Kleen, or equivalent.
- (2) Align the body side cladding with the slots in the door. Press the adhesive pad to the door and snap the retainers into the slots.

REMOVAL-FRONT DOOR

- (1) Open the front door.
- (2) Using a trim stick, pry the upper rear edge off the door. Continue to the front edge of the front door (Fig. 55).
- (3) Using a heat gun, warm the adhesive tape on the lower edge of the cladding and pull the cladding from the door.

INSTALLATION-FRONT DOOR

- (1) Clean the area thoroughly with Mopar Super Kleen, or equivalent.
- (2) Align the body side cladding with the slots in the door. Press the adhesive pad to the door and snap the retainers into the slots.

SILL MOLDING

REMOVAL

- The sill trim molding is held in place with molded in snap retainers (Fig. 56).
- (1) Using a trim stick or other suitable device, carefully pry up one corner of the sill trim.

REMOVAL AND INSTALLATION (Continued)

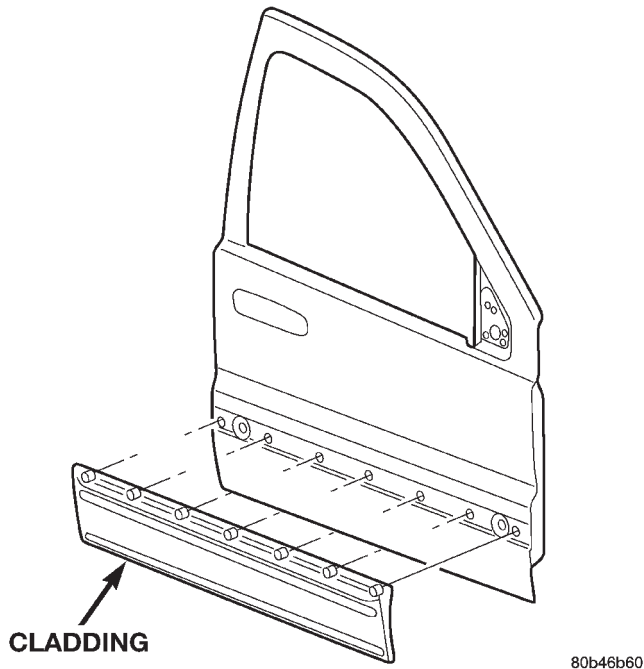

- (2) Grasp the edge of the trim and pull up gently to release the snap retainers.

INSTALLATION

- (1) Position the sill molding on the door sill.
- (2) Press the snap retainers into place.

A-PILLAR TRIM**REMOVAL**

The A-pillar trim is attached to the A-pillar with spring clips.

- (1) Grasp A-pillar trim and pull trim outward from A-pillar (Fig. 57).
- (2) Separate A-pillar trim from A-pillar.

INSTALLATION

- (1) Position A-pillar trim on A-pillar and, starting at the bottom, press into place.
- (2) Using a trim stick or other suitable tool, carefully cover the edge of the trim with weatherstrip.

80b46b60

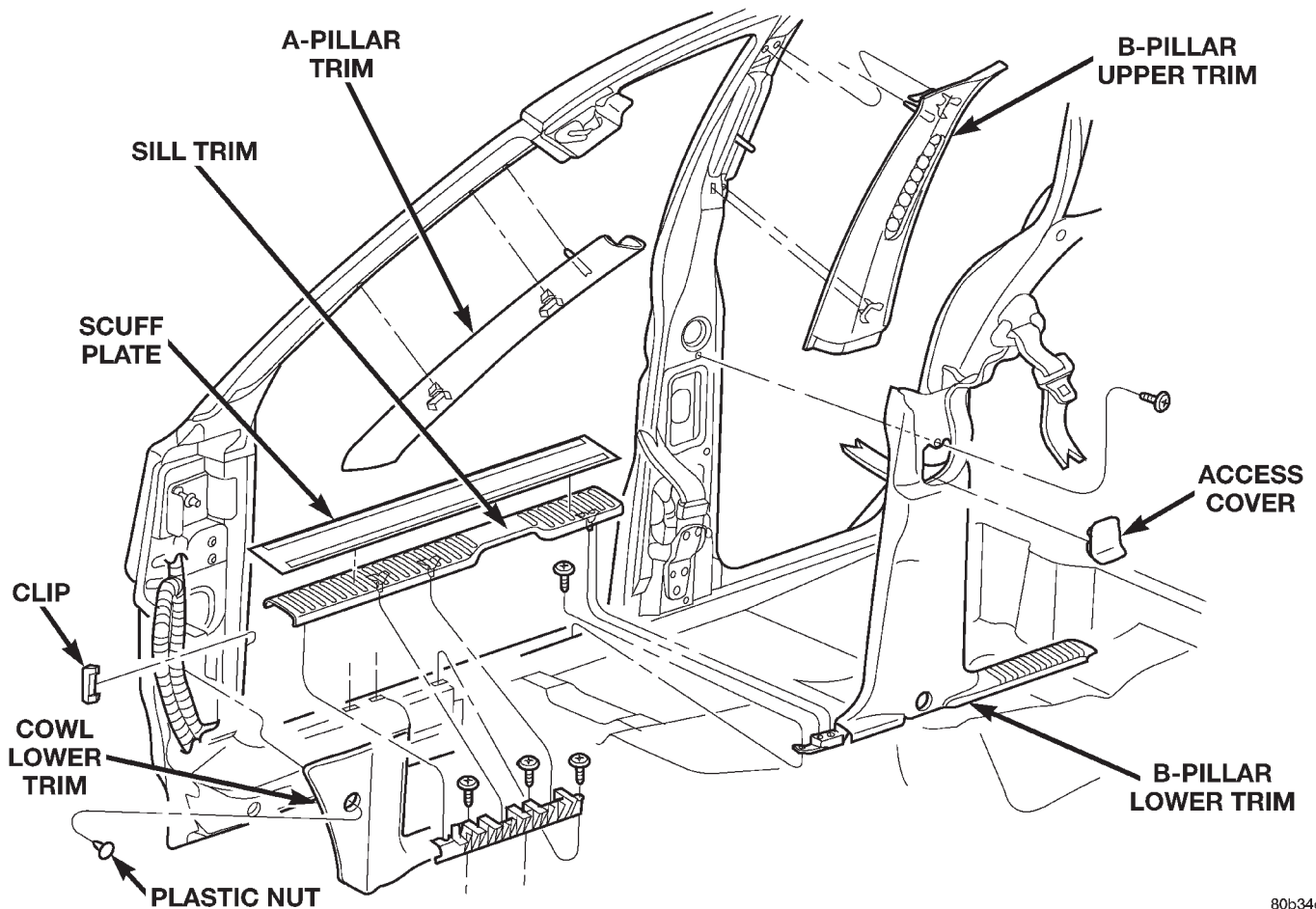
Fig. 55 Front Door Cladding*Fig. 56 Sill Trim Molding*

80b34ee7

REMOVAL AND INSTALLATION (Continued)

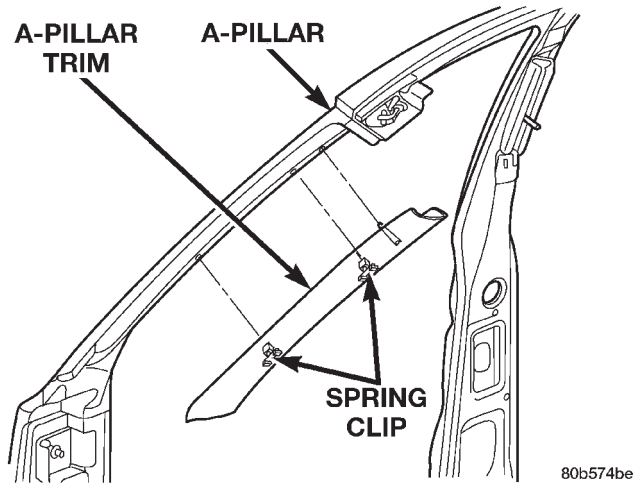

Fig. 57 A-Pillar Trim

COWL LOWER TRIM

REMOVAL

- (1) Remove front door sill trim.
- (2) Remove screws attaching cowl trim to floor.
- (3) Remove plastic nut.
- (4) Grasp cowl trim and pull outward to separate from clip.
- (5) Separate cowl trim from vehicle.

INSTALLATION

- (1) Position cowl trim and press into place.
- (2) Install screws attaching cowl trim to floor.
- (3) Install plastic nut.
- (4) Install front door sill trim.

OVERHEAD ASSIST HANDLE

REMOVAL

- (1) Remove the screws holding the assist handle to the roof panel.
- (2) Remove the assist handle from the roof panel.

INSTALLATION

- (1) Align the assist handle with the screw holes in the roof panel.
- (2) Install the screws holding the assist handle to the roof panel.

FRONT DOOR SCUFF PLATE

REMOVAL

- (1) Using a trim stick or other suitable tool, carefully pry up the scuff plate from the door sill (Fig. 58).
- (2) Remove the scuff plate.

INSTALLATION

- (1) Install the scuff plate on the door sill.

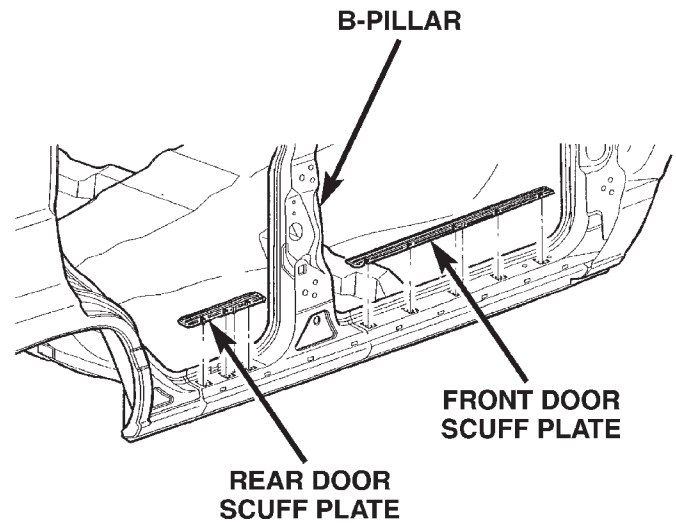

Fig. 58 Door Sill Scuff Plates

- (2) Press the molded in snap retainers into the door sill.

B-PILLAR UPPER TRIM

REMOVAL

- (1) Remove shoulder belt height adjustment knob.
- (2) Remove front seat belt turning loop.
- (3) Remove the screw attaching lower B pillar trim.
- (4) Pull lower B pillar trim out far enough to remove upper trim panel.
- (5) Grasp upper B-pillar trim and pull outward to detach from B-pillar (Fig. 59).

INSTALLATION

- (1) Position trim panel on B-pillar.
- (2) Ensure trim panel covers inner edge of door opening weatherstrip and press inward to seat.
- (3) Install screw attaching lower B pillar trim panel.
- (4) Install front seat belt turning loop.
- (5) Install shoulder belt height adjustment knob.

B-PILLAR LOWER TRIM

REMOVAL

- (1) Remove front door sill trim.
- (2) Remove front seat shoulder belt anchor bolt.
- (3) Remove front seat shoulder belt height adjustment knob and turning loop.
- (4) Remove screw attaching front of quarter panel trim to floor.

REMOVAL AND INSTALLATION (Continued)

- (5) Remove screws attaching front and rear of B-pillar lower trim to floor.
- (6) Remove screw attaching B-pillar lower trim to B-pillar (Fig. 59).
- (7) Grasp B-pillar lower trim and pull outward to separate from B-pillar.
- (8) Route seat/shoulder belt through access slot in B-pillar lower trim.
- (9) Separate B-pillar lower trim from B-pillar.

INSTALLATION

- (1) Position B-pillar lower trim panel at B-pillar.
- (2) Route seat/shoulder belt through access slot in B-pillar lower trim.
- (3) Press B-pillar lower trim onto B-pillar.
- (4) Install screw attaching B-pillar lower trim to B-pillar.
- (5) Install screw attaching front of B-pillar lower trim to floor.
- (6) Install screw attaching front of quarter panel trim to floor.
- (7) Install front seat shoulder belt anchor bolt.
- (8) Install front seat shoulder belt height adjustment knob and turning loop.

- (9) Install front door sill trim.

REAR DOOR SCUFF PLATE

REMOVAL

- (1) The rear door scuff plate is attached with mold-in snap retainers.
- (2) Using a trim stick or other suitable tool, carefully pry the scuff plate from the sill (Fig. 58).

INSTALLATION

- (1) Position the scuff plate on the sill and snap into place.

C-PILLAR UPPER TRIM

REMOVAL

- (1) Remove rear shoulder belt turning loop.
- (2) Remove rear shoulder belt height adjustment knob.
- (3) Remove screws attaching quarter panel trim.
- (4) Pull quarter panel trim outward as necessary.
- (5) Grasp C-pillar upper trim and pull outward to disengage from C-pillar (Fig. 60).

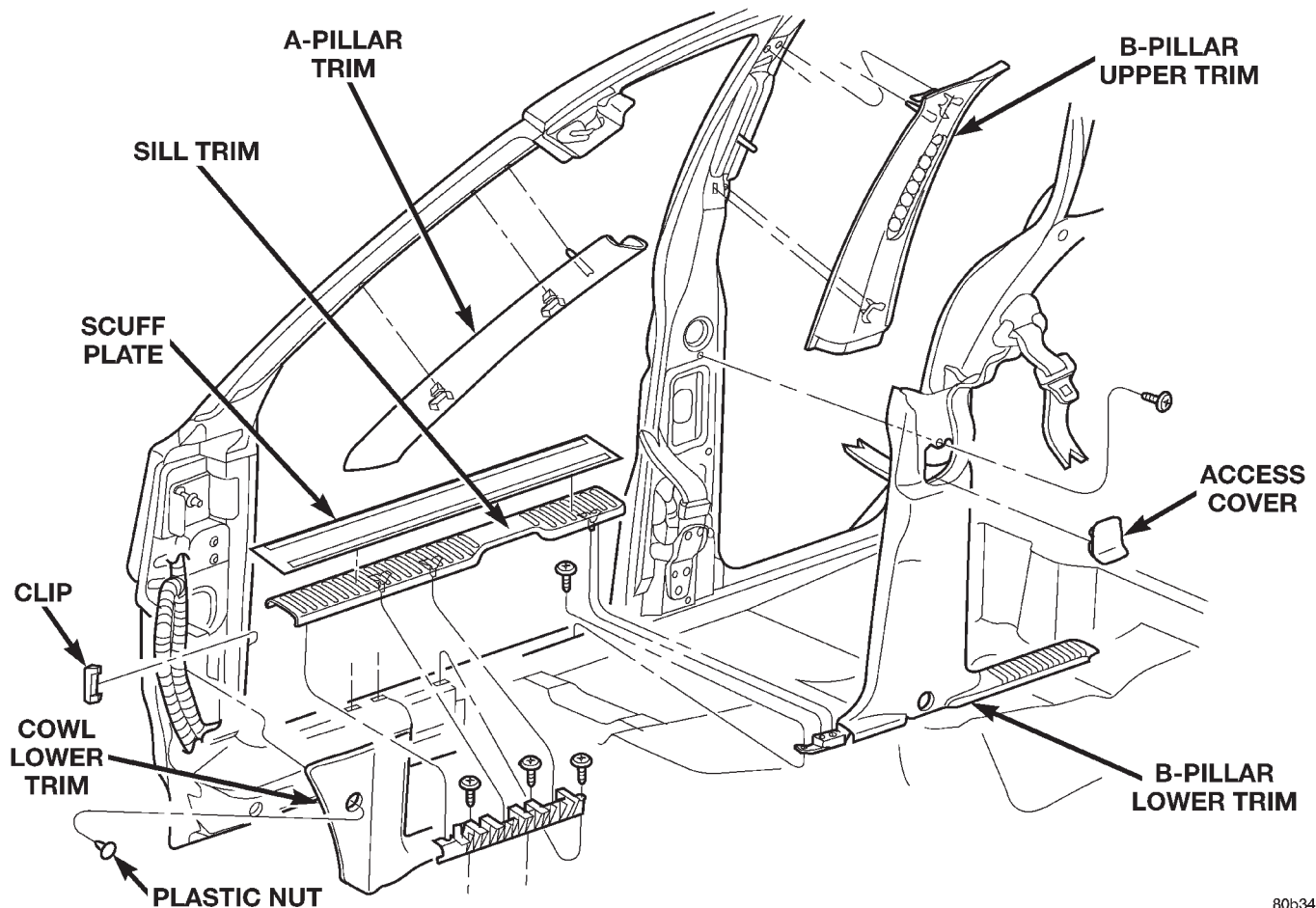

Fig. 59 B-Pillar Trim Panel

REMOVAL AND INSTALLATION (Continued)

- (6) Route rear shoulder belt through access hole.
- (7) Separate C-pillar upper trim from vehicle.

INSTALLATION

- (1) Position C-pillar upper trim at C-pillar.
- (2) Route rear shoulder belt through access hole.
- (3) Press C-pillar upper trim onto C-pillar.
- (4) Press quarter panel trim into place as necessary.
- (5) Ensure front edge of trim is covered by weatherstrip.
- (6) Install screws attaching quarter panel trim.
- (7) Install rear shoulder belt height adjustment knob.
- (8) Install rear shoulder belt turning loop.

QUARTER PANEL TRIM

REMOVAL

- (1) Move rear seat to cargo position.
- (2) If equipped, remove sunshade cover.
- (3) Remove screw attaching quarter panel trim to lower B pillar trim (Fig. 60).
- (4) Open liftgate.

- (5) Remove upper and lower liftgate opening trim panels.
- (6) Remove D-pillar upper trim.
- (7) Remove storage bin (right side only).
- (8) Remove C-pillar upper trim panel.
- (9) Remove mounting screws.
- (10) Pull quarter trim panel forward and disengage connectors for CD player and power outlet, if equipped.
- (11) Pull quarter trim panel extension in the rear door opening upward.
- (12) Remove rear quarter trim panel.

INSTALLATION

- (1) Position quarter trim panel, engage connectors for CD player and power outlet, if equipped, and align screw holes.
- (2) Install quarter trim panel.
- (3) Install C-pillar upper trim panel.
- (4) Install storage bin.
- (5) Install D-pillar upper trim panel.
- (6) Install upper and lower liftgate opening trim panels.
- (7) Install screw at lower B pillar.

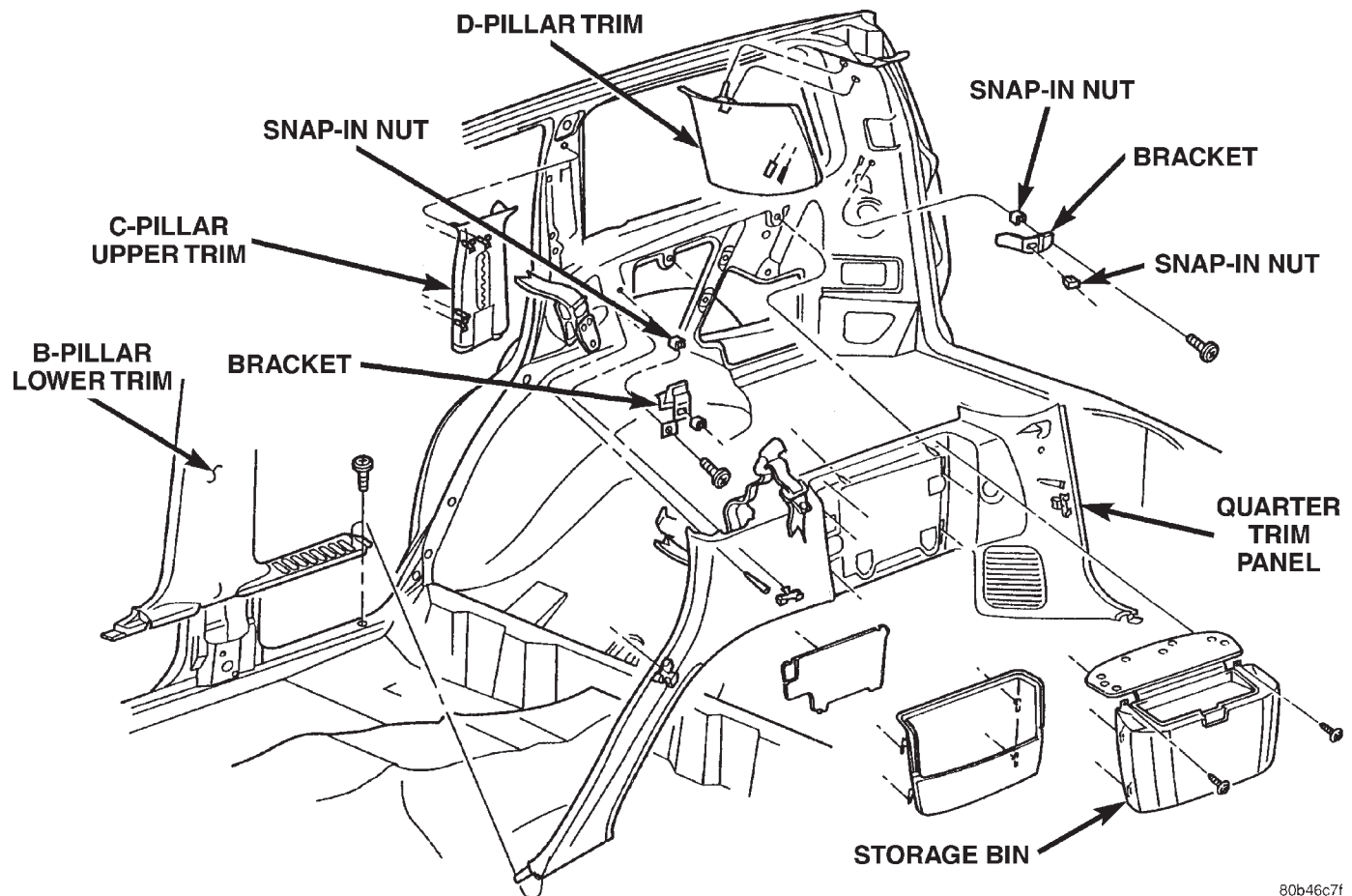

Fig. 60 Right Side Trim Panel

REMOVAL AND INSTALLATION (Continued)

- (8) If equipped, install sunshade cover.
- (9) Install cargo loops.
- (10) Move the rear seat to the upright position.

STORAGE BIN

REMOVAL

- (1) Open the storage bin lid and remove screws on each side of the lid hinge.
- (2) Pull upward sharply on the bottom of the bin to disengage hooks.
- (3) Raise bin and move inboard to disengage the quarter trim panel.

INSTALLATION

- (1) Position the bin hooks high in the slots on the quarter trim panel.
- (2) Push downward until the bin snaps into place.
- (3) Install the hinge screws.

D-PILLAR TRIM

REMOVAL

The D-pillar trim is attached to the D-pillar with spring clips.

- (1) Remove liftgate opening upper trim panel.
- (2) Grasp D-pillar trim and pull outward from D-pillar (Fig. 61).
- (3) Separate D-pillar trim from D-pillar.

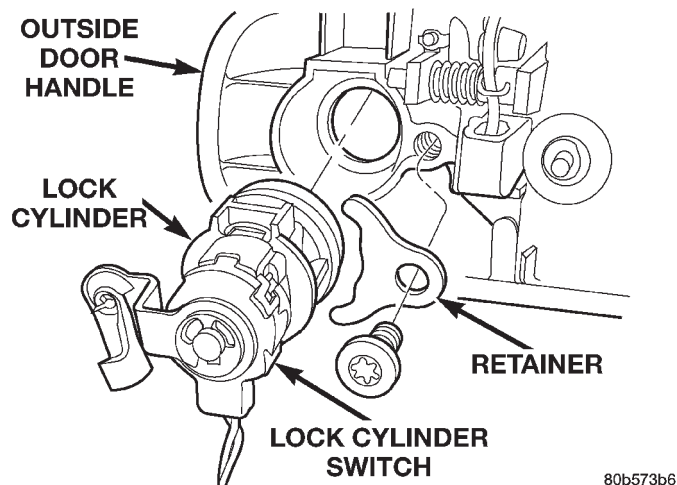

Fig. 61 D-Pillar Trim

INSTALLATION

- (1) Position D-pillar trim panel at D-pillar and press into place.
- (2) Install upper liftgate opening trim panel.

FRONT SHOULDER BELT

REMOVAL

- (1) Move the seat to the fully forward position.
- (2) Unsnap turning loop cover.
- (3) Remove upper anchor bolt.
- (4) Remove the B pillar trim.
- (5) Remove the bolt attaching the retractor to the B pillar.
- (6) Remove the bolt attaching the belt anchor to the B pillar.
- (7) Disengage retractor wire harness.
- (8) Remove the belt and retractor assembly.

INSTALLATION

- (1) Position the belt and retractor assembly on the B pillar.
- (2) Install the bolt attaching the belt anchor to the B pillar.
- (3) Install the bolt attaching the retractor to the B pillar.
- (4) Tighten the anchor bolts to 37N·m (27ft. lbs.).
- (5) Install the B pillar trim.
- (6) Install the upper anchor bolt. Tighten the anchor bolt to 37N·m (27ft. lbs.).
- (7) Close the turning loop cover.

FRONT SHOULDER BELT BUCKLE

REMOVAL

NOTE: The shoulder belt buckle is fastened to the seat frame.

- (1) Move the seat to the fully rearward position.
- (2) Remove the bolt holding the seat belt buckle to the seat frame.
- (3) Separate the seat belt buckle from the vehicle.

INSTALLATION

- (1) Install the seat belt buckle on the seat frame.
- (2) Tighten the anchor bolt to 37N·m (27 ft. lbs.).

REAR SEAT BELT BUCKLE

The rear seat belt buckle is integral with the seat frame and not serviced as a separate part.

REMOVAL AND INSTALLATION (Continued)

FLOOR CONSOLE

CAUTION: The ACM should be depowered by disconnecting the negative battery cable in any operation requiring the key to be turned "ON", while working in the console area. E.G. console, carpet, or seat removal or installation; shifter linkage adjustment or replacement; parking brake cable replacement or adjustment. Failure to take proper precautions could result in accidental airbag deployment and possible personal injury.

REMOVAL

- (1) Set park brake.
- (2) Place transmission shift lever and transfer case lever in full rearward position.
- (3) Remove mat from front bin and remove screws attaching front of console to floor (Fig. 62).
- (4) Remove screws attaching rear bin to console.
- (5) Remove rear bin.
- (6) Pull rear passenger cupholder outward to access screws.
- (7) Remove screws attaching rear of console to floor.
- (8) Lift the console upward and rearward.
- (9) Remove console from vehicle.

INSTALLATION

- (1) Position console in vehicle. Ensure rear passenger HEVAC duct is engaged.
- (2) Install screws attaching rear of console to floor.
- (3) Position rear bin in console.
- (4) Install screws attaching rear bin to console.
- (5) Install screws attaching front of console to floor and place front bin mat in front bin.
- (6) Return transmission shift lever and transfer case lever to original position.
- (7) Release park brake.

FRONT CARPET

REMOVAL

- (1) Remove door sill trim and lower "B" pillar trim.
- (2) Remove front seats and lower cushions of rear seats.
- (3) Remove center floor console.
- (4) Remove any other interfering trim or molding.
- (5) Lift carpet and mat from floor panel.

INSTALLATION

- (1) Clean the floor panel area as necessary.
- (2) Carefully lay the carpet and mat on the floor panel. Align the carpet to allow installation of the components fastened to the floor panel.
- (3) Install the center console.
- (4) Install the front and rear seat units.

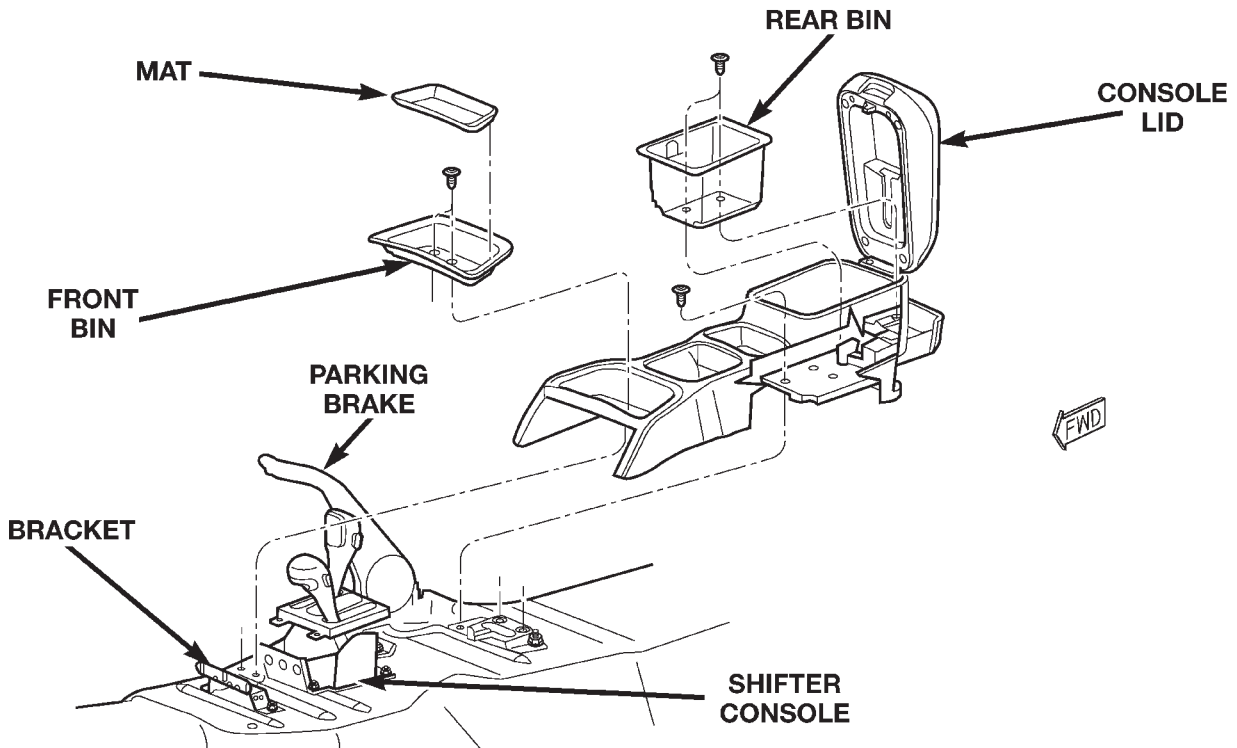

Fig. 62 Floor Console

REMOVAL AND INSTALLATION (Continued)

(5) Install the lower "B" pillar trim and the door sill trim.

(6) Install any other moldings or trim panels removed.

CARGO AREA CARPET

REMOVAL

- (1) Lift tailgate.
- (2) Fold rear seat cushions forward.
- (3) Remove rear seat backs, shoulder belts and buckles.
- (4) Remove the retractable security cargo cover assembly.
- (5) Remove the spare tire cover.
- (6) Remove the rear cargo tie down footman loops. The side mounted footman loops are retained by screws. The floor footman loops are riveted (Fig. 63).
- (7) Remove the "C" pillar trim and CD changer, if equipped.
- (8) Remove the Infinity amp, if equipped.
- (9) Lift the carpet.

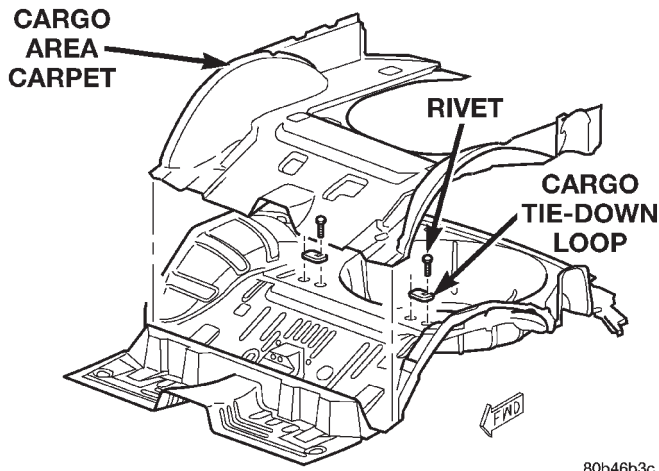

Fig. 63 Cargo Area Carpet

INSTALLATION

- (1) Thoroughly clean the area with Mopar Super Kleen, or equivalent.
- (2) Lay the new carpet in.
- (3) Install the "C" pillar trim and CD changer, if equipped.
- (4) Install the footman loops.
- (5) Install the seat backs, shoulder belts and buckles.
- (6) Install the Infinity amp, if equipped.
- (7) Install the spare tire cover.
- (8) Install the retractable security cover.

REARVIEW MIRROR

REMOVAL

- (1) If equipped, disconnect mirror harness connector.
- (2) Loosen the mirror base setscrew (Fig. 64).
- (3) Slide the mirror base upward and off the bracket.

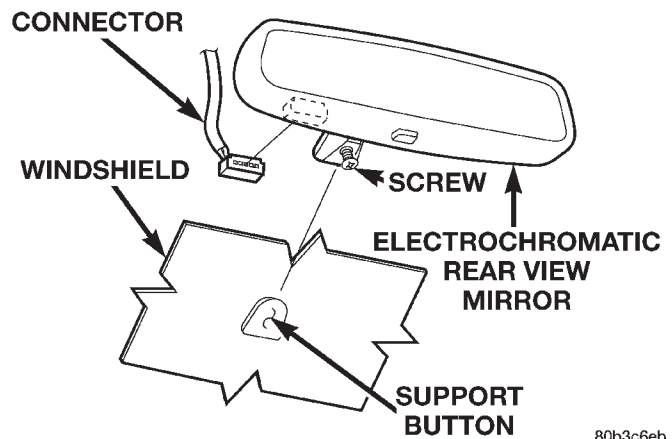

80b3c6eb

Fig. 64 Rearview Mirror

INSTALLATION

- (1) Position the mirror base at the bracket and slide it downward onto the support bracket.
- (2) Tighten the setscrew 1 N·m (15 in. lbs.) torque.
- (3) If equipped, connect mirror harness connector.

REARVIEW MIRROR SUPPORT BRACKET

INSTALLATION

- (1) Mark the position for the mirror bracket on the outside of the windshield glass with a wax pencil.
- (2) Clean the bracket contact area on the glass. Use a mild powdered cleanser on a cloth saturated with isopropyl (rubbing) alcohol. Finally, clean the glass with a paper towel dampened with alcohol.
- (3) Sand the surface on the support bracket with fine grit-sandpaper. Wipe the bracket surface clean with a paper towel.
- (4) Apply accelerator to the surface on the bracket according to the following instructions:
 - Crush the vial to saturate the felt applicator.
 - Remove the paper sleeve.
 - Apply accelerator to the contact surface on the bracket.
 - Allow the accelerator to dry for five minutes.
 - Do not touch the bracket contact surface after the accelerator has been applied.
- (5) Apply adhesive accelerator to the bracket contact surface on the windshield glass. Allow the accelerator to dry for one minute. Do not touch the glass

REMOVAL AND INSTALLATION (Continued)

contact surface after the accelerator has been applied.

(6) Install the bracket according to the following instructions:

- Apply one drop of adhesive at the center of the bracket contact-surface on the windshield glass.
- Apply an even coat of adhesive to the contact surface on the bracket.
- Align the bracket with the marked position on the windshield glass.
- Press and hold the bracket in place for at least one minute.

NOTE: Verify that the mirror support bracket is correctly aligned, because the adhesive will cure rapidly.

(7) Allow the adhesive to cure for 8-10 minutes. Remove any excess adhesive with an alcohol-dampened cloth.

(8) Allow the adhesive to cure for an additional 8-10 minutes before installing the mirror.

SUNVISOR

REMOVAL

- (1) Remove screws attaching sunvisor arm support bracket to headliner and roof panel.
- (2) Disengage electrical connections for vanity mirror, if equipped.
- (3) Detach sunvisor from support bracket.
- (4) Remove sunvisor from vehicle.
- (5) Remove retaining screw and support bracket.

INSTALLATION

- (1) Install the retaining screw and support bracket.
- (2) Position the sunvisor in the vehicle.
- (3) Connect the electrical harness for the lighted vanity mirror, if equipped.
- (4) Attach the sunvisor to the support bracket.
- (5) Install the support bracket w/sunvisor onto the headliner and roof panel.

HEADLINER

REMOVAL

CAUTION: The headliner is a one-piece, molded component. It has limited flexibility and must not be bent. Damage may possibly result.

- (1) Record radio presets and disconnect negative battery cable.
- (2) Remove "A", "B", "C", and "D" pillar trim moldings.

- (3) Remove the sun visors. Disconnect vanity lamp wiring.
- (4) Remove assist handles from roof rails.
- (5) Remove dome lamp and overhead console, if equipped.
- (6) Remove rear cargo/dome lamp.
- (7) Remove sun roof pinch welt, if equipped.
- (8) Disengage rear washer hose from liftgate (Fig. 65).
- (9) Disengage the wire harness connectors at rear of headliner.
- (10) Disconnect the rear washer hose at the left "A" pillar (Fig. 66).
- (11) Disengage the wire harness for the sunroof, if equipped.
- (12) Fold down the rear seats, move the front seats full forward, and lower the front seat backs.
- (13) Partially lower the headliner and disengage the sunroof drain hoses, if equipped (Fig. 67).
- (14) With the aid of an assistant, remove the headliner through the liftgate opening.

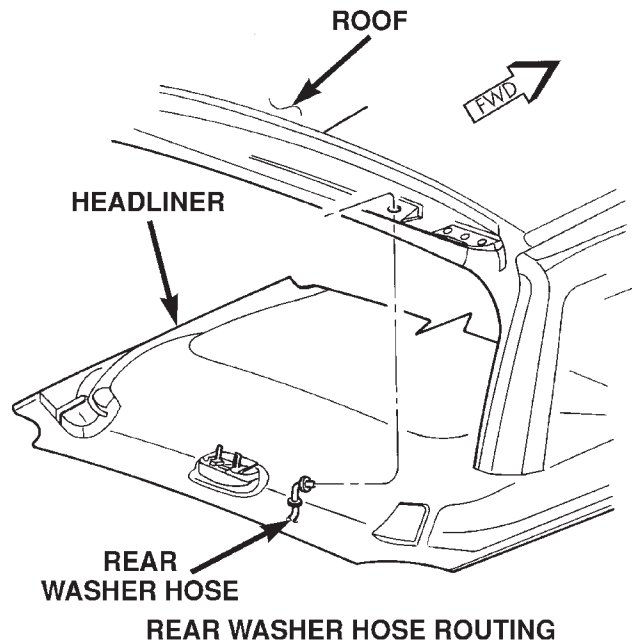

80b9a4cf

Fig. 65 Liftgate Washer Hose Routing at Rear of Headliner

INSTALLATION

- (1) With the aid of an assistant, position the headliner in the vehicle.
- (2) Connect the sunroof drain hoses, if equipped.
- (3) Connect the sunroof harness, the rear wire harnesses, and the washer hose at the "A" pillar and at the liftgate.
- (4) Install the sunroof pinch welt, if equipped.
- (5) Install the roof rail assist handles.
- (6) Install the sun visors and overhead console.

REMOVAL AND INSTALLATION (Continued)

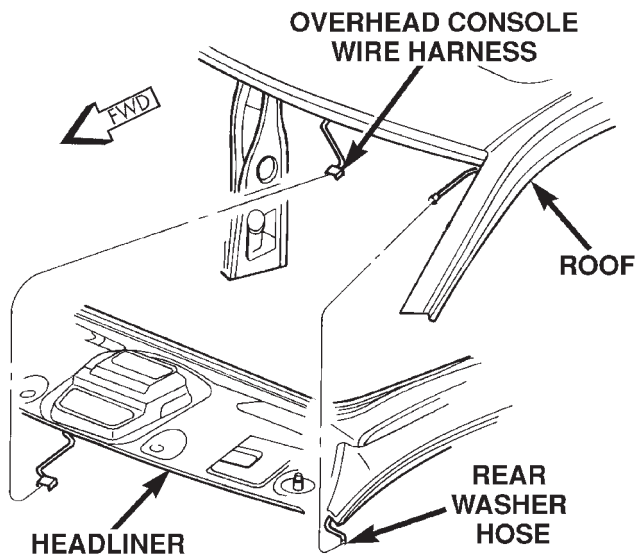

REAR WASHER HOSE ROUTING

80b9a4d0

Fig. 66 Rear Liftgate Washer Hose Routing at A Pillar

- (7) Install the rear cargo/dome lamp.
- (8) Install the "A", "B", "C", and "D" pillar trim.
- (9) Connect the negative battery cable.

LIFTGATE TRIM PANEL

NOTE: The liftgate trim panel is attached with screws and spring clips.

REMOVAL

- (1) Remove the screws securing the liftgate trim panel to the liftgate (Fig. 68).
- (2) Disconnect the rear window defroster wires.
- (3) Using a trim stick, or other suitable tool, pry the liftgate trim panel off the liftgate.

INSTALLATION

- (1) Align the liftgate trim panel spring clips and press the panel into the liftgate.
- (2) Install the trim panel screws.
- (3) Connect the rear defroster wires.

LOWER LIFTGATE OPENING TRIM PANEL

REMOVAL

- (1) Remove screws at outboard end of lower liftgate trim panel.
- (2) Open the spare tire cover and remove the screws near the center of the lower liftgate trim panel (Fig. 69).
- (3) Remove the lower liftgate trim panel.

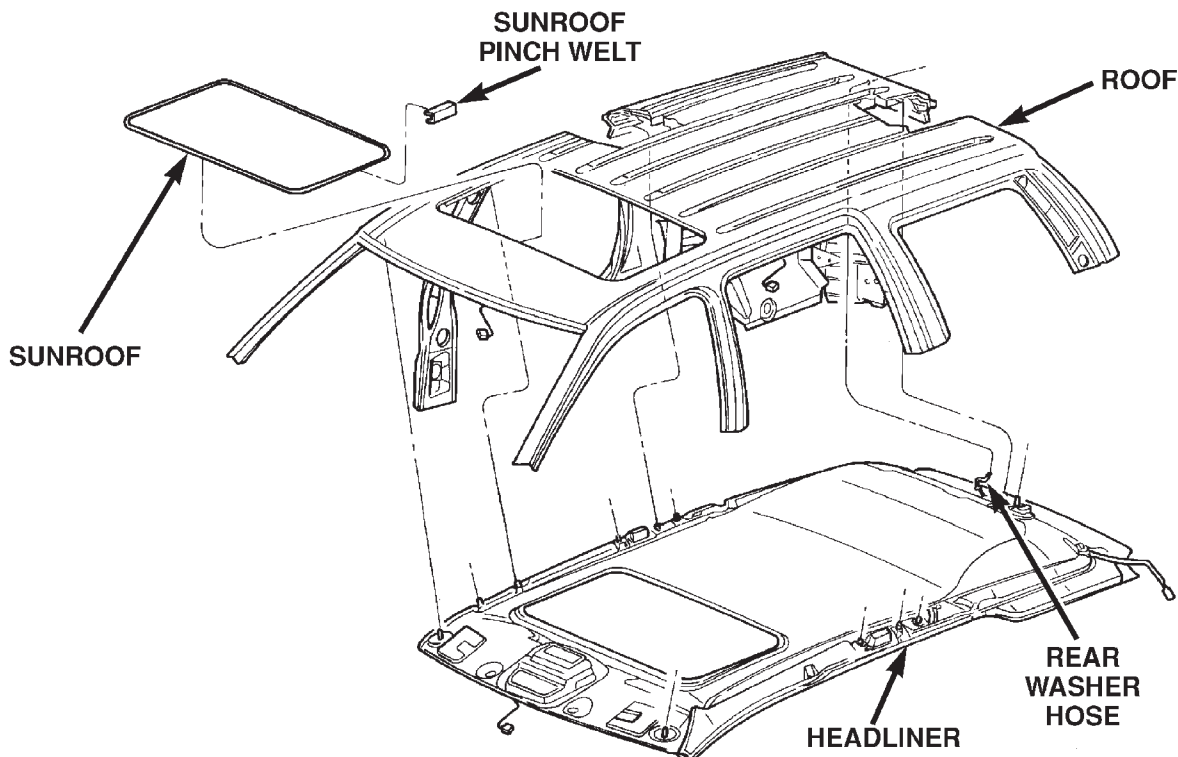

80b9a4ce

Fig. 67 Headliner

REMOVAL AND INSTALLATION (Continued)

- (2) Install the screws in the liftgate opening trim panel.
- (3) Install the spare tire cover.

UPPER LIFTGATE OPENING TRIM PANEL

REMOVAL

- (1) Grasp the forward edge of the upper liftgate opening trim panel and pull downward to disengage the spring clips.
- (2) Pull the upper liftgate opening trim panel rearward to disengage the hooks in the headliner (Fig. 69).

INSTALLATION

- (1) Align the upper liftgate opening trim panel with the slots in the headliner and engage the hooks.
- (2) Align the spring clips with the holes in the roof panel and press upward to engage the clips.

LIFTGATE INSULATOR

REMOVAL

- (1) Remove the liftgate trim panel.
- (2) Separate the liftgate insulator from the liftgate and trim panel (Fig. 70).

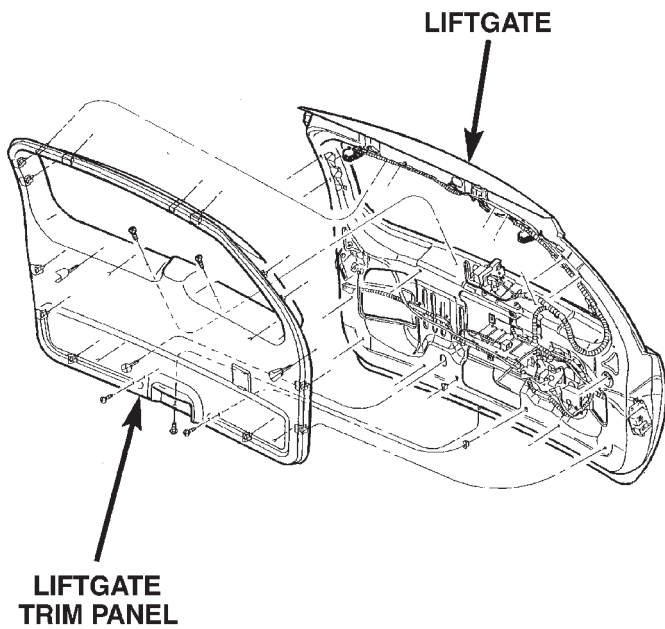

80ba7980

Fig. 68 Liftgate Trim Panel

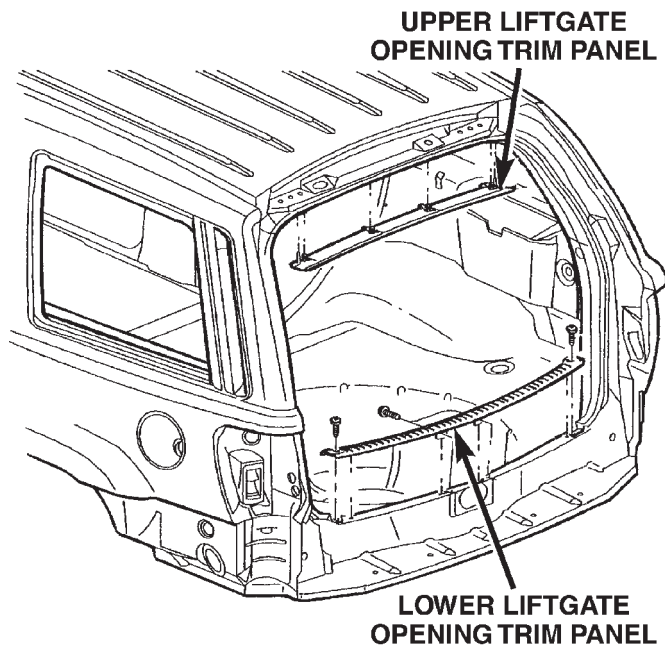

80ba7979

Fig. 69 Liftgate Opening Trim Panel

INSTALLATION

- (1) Align the screw holes and locators to the holes in the liftgate opening.

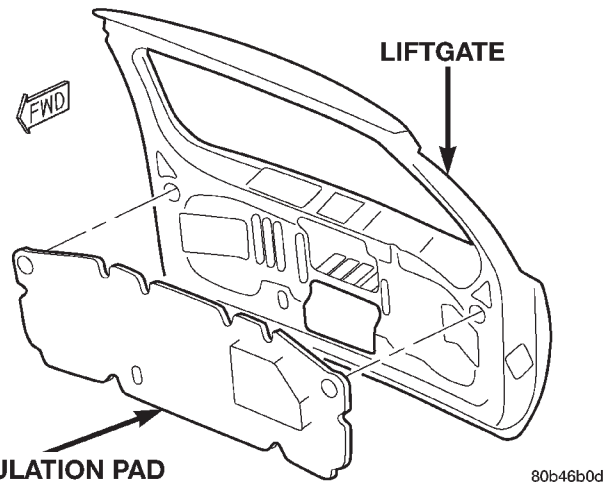

80b46b0d

Fig. 70 Liftgate Insulator Pad

INSTALLATION

- (1) Thoroughly clean the area of any adhesive or insulation material.
- (2) Install the insulator in the liftgate.
- (3) Install the liftgate trim panel.
- (4) Close the liftgate and check the operation of the liftgate latch and rear wiper/washer, if equipped.

REMOVAL AND INSTALLATION (Continued)

LIFTGATE

REMOVAL

CAUTION: DO NOT DISCONNECT THE SUPPORT ROD CYLINDERS WITH THE LIFTGATE CLOSED. THE SUPPORT ROD PISTONS ARE OPERATED BY HIGH PRESSURE GAS. THIS PRESSURE COULD CAUSE DAMAGE AND /OR PERSONAL INJURY IF THEY ARE REMOVED WHILE THE PISTONS ARE COMPRESSED.

- (1) Open the liftgate. Support the liftgate for ease of repair.
- (2) Remove the liftgate trim panel.
- (3) Remove the prop rods from the liftgate.
- (4) Unplug the wire harnesses and disconnect the washer hose.
- (5) Mark the hinge location with a wax pencil or other suitable device (Fig. 71).
- (6) Remove the hinge screws and remove liftgate from vehicle.

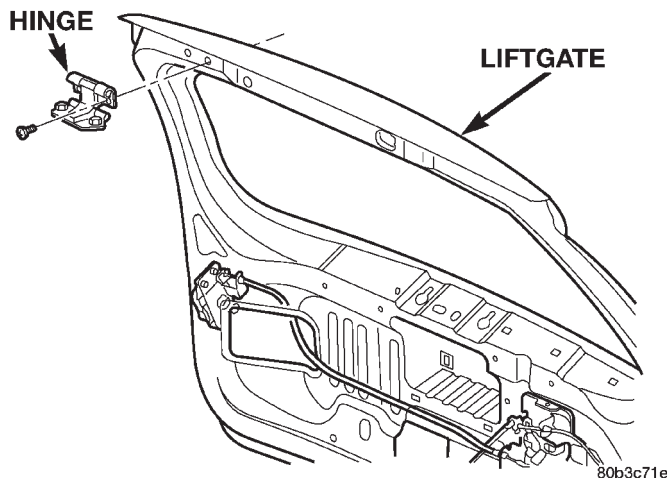

Fig. 71 Liftgate

INSTALLATION

- (1) Position the liftgate on the vehicle and align the witness marks.
- (2) Install the hinge screws at liftgate. Tighten hinge screws to 28N·m (21ft. lbs.).
- (3) Connect the wire harnesses and the washer hose.
- (4) Install the trim panel.
- (5) Install the prop rods.
- (6) Close the liftgate and check for proper latching and alignment.

LIFTGATE HINGE

NOTE: It is not necessary to remove the liftgate to replace one or both hinges. The hinges can be replaced one at a time.

REMOVAL

- (1) Open the liftgate. Support the liftgate for ease of repair.
- (2) Remove the liftgate header trim panel.
- (3) Mark the hinge location with a grease pencil or other suitable device.
- (4) Remove the hinge screws (Fig. 71).
- (5) Remove hinge.

INSTALLATION

- (1) Position the hinge on the roof panel and on the liftgate. (Use 3M™ Fast and Firm or equivalent on the hinge to body mating surfaces as a sealant.)
- (2) Install and tighten hinge screws at roof panel to 28N·m (21 ft. lbs.).
- (3) Install hinge screws at liftgate. Tighten screws to 28N·m (21 ft. lbs.).
- (4) Install liftgate header trim panel.
- (5) Check the liftgate for proper alignment and operation.

LIFTGATE OUTSIDE HANDLE

REMOVAL

- (1) Raise the liftgate.
- (2) Remove the liftgate trim panel (Fig. 72).
- (3) Remove the latch, outside handle linkage, and power lock connector.
- (4) Remove the fasteners attaching the outside handle to the liftgate.
- (5) Remove the outside handle from the liftgate.

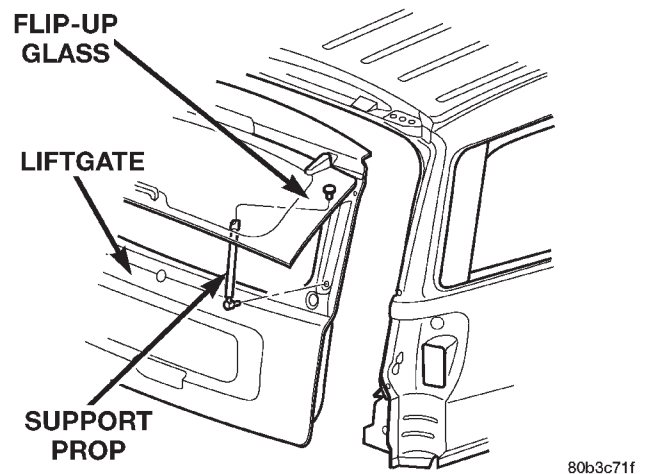
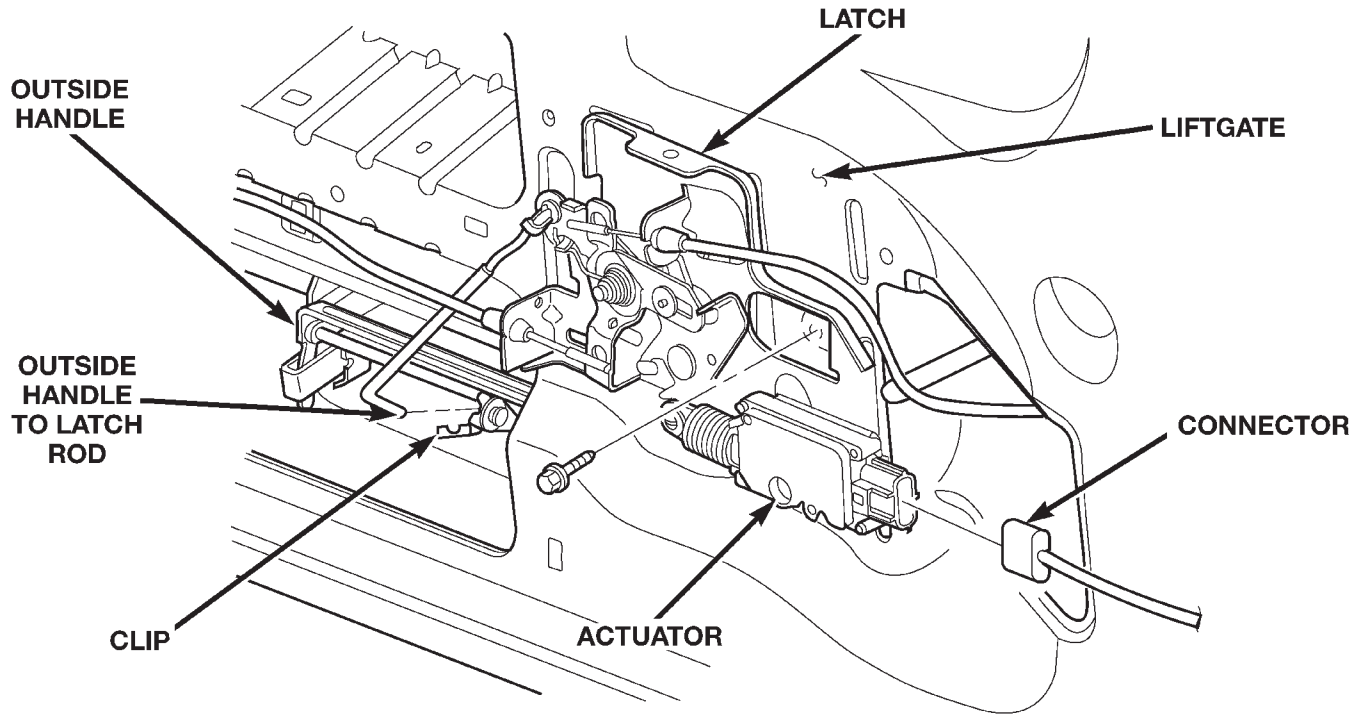

Fig. 72 Liftgate Outside Handle

INSTALLATION

- (1) Position the outside handle on the liftgate.
- (2) Install the fasteners attaching outside handle to liftgate.
- (3) Connect outside handle link and power lock connector.
- (4) Install liftgate trim panel.

REMOVAL AND INSTALLATION (Continued)



80b34e98

Fig. 73 Liftgate Latch

LIFTGATE LATCH

REMOVAL

- (1) Raise the liftgate.
- (2) Remove the liftgate trim panel (Fig. 73).
- (3) Disconnect the power connector.
- (4) Disconnect the outside handle link from the latch.
- (5) Remove the latch screws and remove latch.

INSTALLATION

- (1) Install the latch into the liftgate and tighten the screws to 7N·m (5 ft. lbs.).
- (2) Connect the outside handle to the liftgate latch.
- (3) Plug in the connector for the power .
- (4) Install the liftgate trim panel.

LIFTGATE LATCH STRIKER

REMOVAL

- (1) Raise liftgate.
- (2) Remove tail lamp.
- (3) Remove nuts attaching striker to D-pillar (Fig. 74).
- (4) Separate striker from D-pillar.

INSTALLATION

- (1) Position striker on D-pillar.

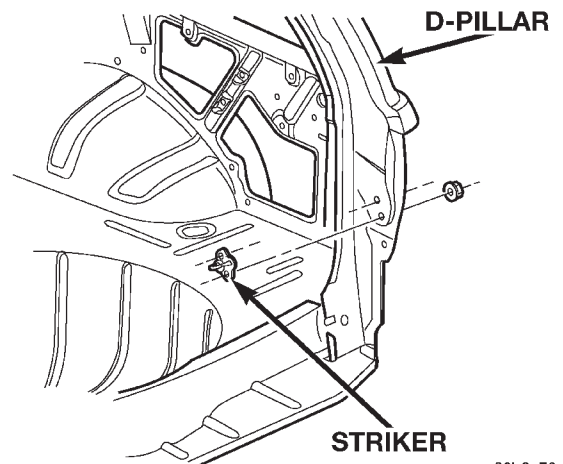

80b3c70e

Fig. 74 Liftgate Latch Striker

- (2) Install nuts attaching striker to D-pillar. Tighten nuts to 10 N·m (7 ft. lbs.) torque.
- (3) Install tail lamp.

LIFTGATE OPENING WEATHERSTRIP

REMOVAL

- (1) Pull seal away from flange around edge of liftgate opening.
- (2) Separate weatherstrip from opening (Fig. 75).
- (3) Clean weatherstrip flange as necessary.

REMOVAL AND INSTALLATION (Continued)

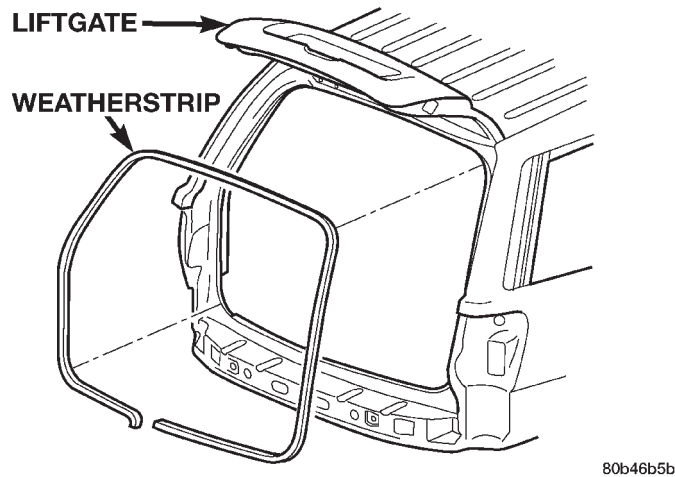
**Fig. 75 Liftgate Opening Weatherstrip****INSTALLATION**

- (1) Position weatherstrip in opening with left end of seal at opening centerline.
- (2) Press weatherstrip onto flange in a clockwise direction.
- (3) Center and butt weatherstrip ends together at centerline.
- (4) If necessary, cut surplus from weatherstrip (non-plug end only).

FLIP UP GLASS**REMOVAL**

CAUTION: DO NOT DISCONNECT THE PROP ROD CYLINDERS WITH THE LIFTGATE FLIP UP GLASS CLOSED. THE PROP ROD PISTONS ARE OPERATED BY HIGH PRESSURE GAS. THIS PRESSURE COULD CAUSE DAMAGE AND/OR PERSONAL INJURY IF THEY ARE REMOVED WHILE THE PISTONS ARE COMPRESSED.

- (1) Using a trim stick or other suitable device, separate the flip up glass hinge cover from the hinge on the liftgate (Fig. 76).
- (2) Open liftgate flip up glass. Support the glass for ease of repair.
- (3) Using a small flat blade or equivalent tool, gently pry open the locking caps on the end of the prop rods.
- (4) Remove prop rod cylinders from ball studs.
- (5) Lower the flip up glass.
- (6) Remove hinge fasteners from liftgate.
- (7) Separate flip up glass from liftgate.

INSTALLATION

- (1) Position flip up glass on liftgate.
- (2) Install hinge fasteners, hand tight only.
- (3) With the glass panel in the fully open position, fully raised position, push the glass forward to com-

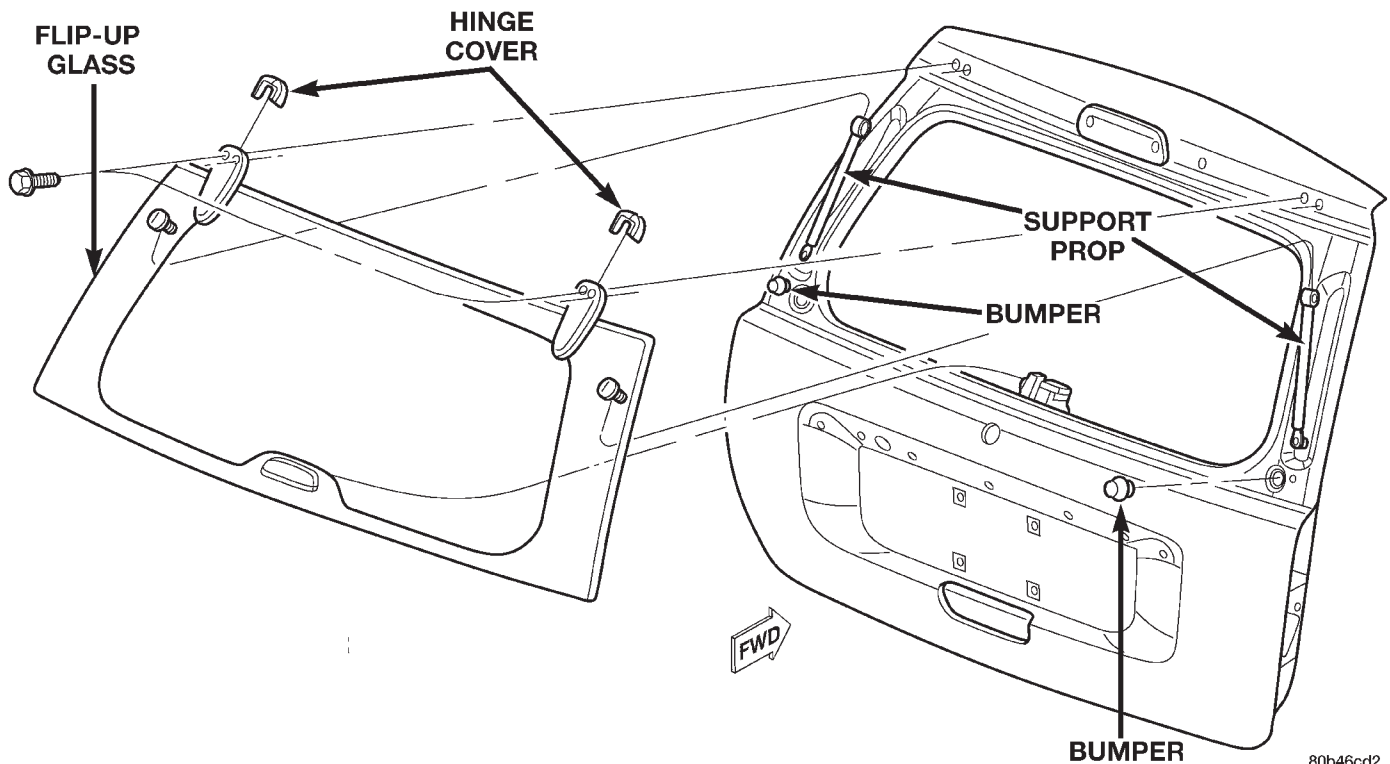
**Fig. 76 Flip-Up Glass**

REMOVAL AND INSTALLATION (Continued)

pletely seat the hinges. Tighten hinge fasteners to 6N·m (60 in. lbs.).

(4) Install prop rods on ball studs and compress locking caps to lock rods on ball studs.

(5) Lower the flip up glass and install the flip up glass hinge cover.

(6) Check the flip up glass for proper alignment and latching.

FLIP UP GLASS WEATHERSTRIP

REMOVAL

- (1) Raise flip up glass.
- (2) Carefully pull the seal away from the flange around the edge of the glass opening (Fig. 77).
- (3) Remove it from the vehicle.

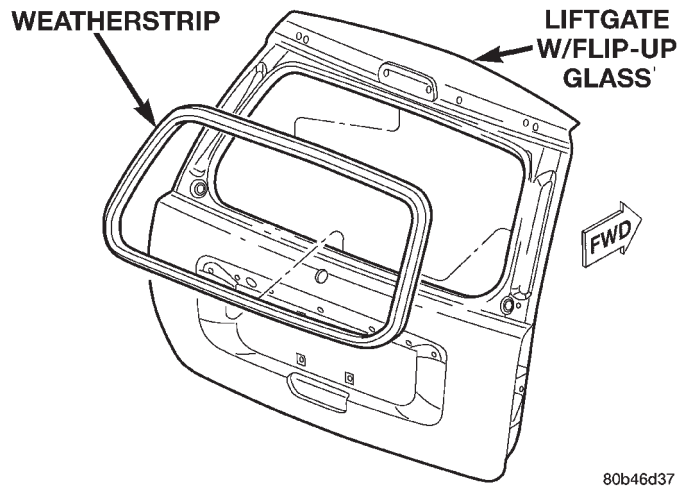

Fig. 77 Flip-up Glass Weatherstrip

INSTALLATION

(1) Thoroughly clean the surface of the flange as necessary.

(2) Align the weather strip seal with the window opening corners.

(3) Firmly seat the seal around the entire flange. But the seal ends together and smooth out any remaining length.

(4) Weatherstrip break should be 120mm left of latch opening. Cut any surplus from non-plug end only.

FLIP UP GLASS SWITCH

REMOVAL

(1) Remove license plate lamp housing/trim panel from liftgate.

(2) Squeeze the locking tabs inward to release the switch from the housing.

(3) Disconnect the switch harness connector, remove the switch from the housing.

INSTALLATION

- (1) Install switch harness connector.
- (2) Position switch in housing, snap switch into place.
- (3) Install license plate lamp housing/trim panel onto liftgate.

FLIP UP GLASS LATCH

REMOVAL

- (1) Open liftgate flip up glass.
- (2) Open liftgate and remove trim panel (Fig. 78).
- (3) Remove latch.
- (4) Disconnect switch connectors.
- (5) Remove latch from liftgate.

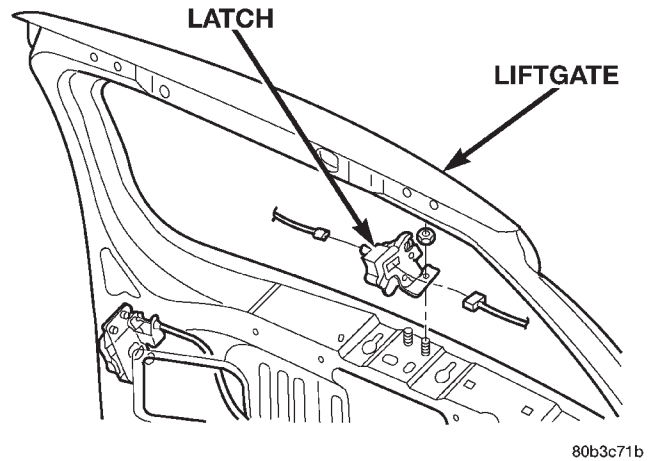

Fig. 78 Flip-up Glass Latch

INSTALLATION

- (1) Position the latch on the liftgate.
- (2) Connect switch connectors.
- (3) Adjust latch to the proper position, and tighten the fasteners to 11 N·m (100 in. lbs.).
- (4) Close flip up glass panel and verify proper operation.
- (5) Install liftgate trim panel.

FLIP UP GLASS LATCH STRIKER

REMOVAL

- (1) Raise flip up glass panel.
- (2) Mark the position of the handle/striker on the glass panel.
- (3) Remove the screws attaching the handle/striker to the glass.

INSTALLATION

(1) Position the handle/striker on the glass panel and align the reference marks.

REMOVAL AND INSTALLATION (Continued)

(2) Install the screws attaching the handle/striker to the glass panel. Tighten the fasteners to 6 N·m (60 in. lbs.).

LICENSE PLATE LAMP HOUSING

REMOVAL

- (1) Remove the screws retaining the lamp housing/trim panel to the liftgate (Fig. 79).
- (2) Disconnect the wire harness for the license plate lamps and the flip up glass switch, if equipped.
- (3) Remove the license plate lamps and the flip up glass switch, if equipped.
- (4) Remove the license plate lamp housing.

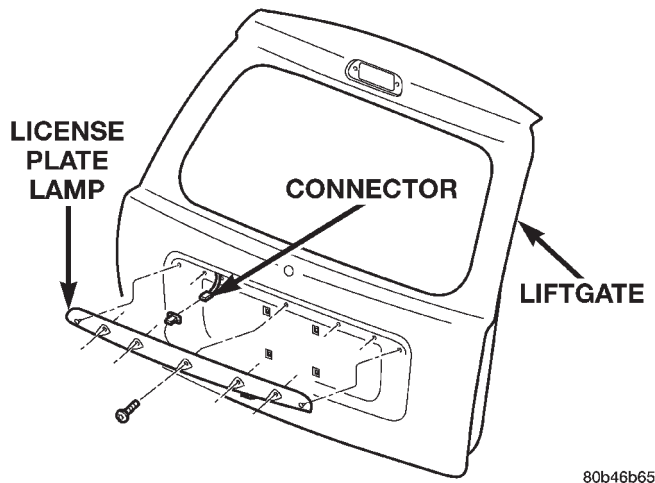

80b46b65

Fig. 79 License Plate Lamp Housing

INSTALLATION

- (1) Install the license plate lamps, and the flip up glass switch, if equipped.
- (2) Connect the wire harnesses for the license plate lamps and the flip up glass switch.
- (3) Install the lamp housing/trim panel on the liftgate.

D-PILLAR APPLIQUE

REMOVAL

- (1) Using a trim stick, carefully pry applique from panel (Fig. 80).

INSTALLATION

- (1) Position applique on panel with retainers aligned.
- (2) Press applique firmly in place.

D-PILLAR AIR EXHAUSTER

REMOVAL

- (1) Remove D-pillar applique.

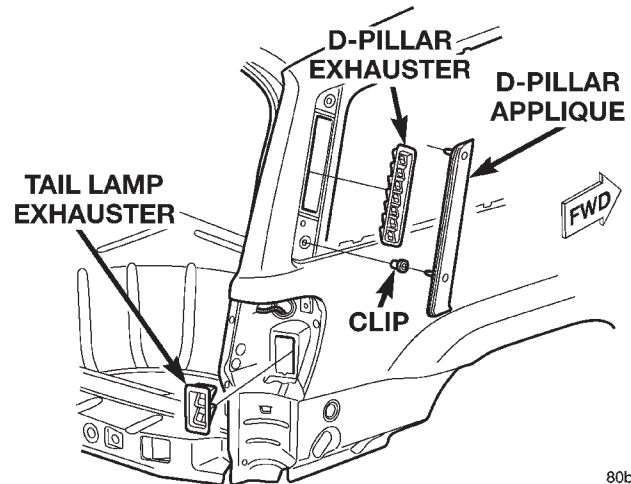

80b46ae0

Fig. 80 D-Pillar Applique & Air Exhauster

- (2) Carefully pry air exhauster from D-pillar using a flat blade screwdriver (Fig. 80).

INSTALLATION

- (1) Reseal air exhauster using foam tape.
- (2) Install air exhauster on D-pillar.
- (3) Install D-pillar applique.

TAIL LAMP AIR EXHAUSTER

REMOVAL

- (1) Remove tail lamp.
- (2) Using a trim stick, pry the top of the air exhauster downward to detach the retaining clips.
- (3) Separate air exhauster from vehicle (Fig. 80).

INSTALLATION

- (1) Position air exhauster in opening.
- (2) Press air exhauster inward to secure.
- (3) Install tail lamp.

LUGGAGE RACK

REMOVAL

NOTE: The skid strips are attached to the roof panel with adhesive.

- (1) Using a trim stick, or other suitable device, pry support cover off.
- (2) If necessary, slide the crossbars to expose the screws attaching the slide rails to the supports.
- (3) Remove the screws retaining the slide rails to the supports.
- (4) Remove the screws attaching the supports to the roof panel.
- (5) Separate the supports from the roof panel.

REMOVAL AND INSTALLATION (Continued)

NOTE: If a crossbar needs to be serviced, the forward or rearward supports will have to be removed.

INSTALLATION

(1) Position the supports on the roof panel and install the screw. Be sure that the gasket is properly seated.

(2) Position the luggage rack on the supports.

(3) Install the screws attaching the side rails to the supports.

(4) Position the supports covers on the supports and press into place.

ADJUSTMENTS**HOOD ADJUSTMENT**

The hood attaching holes are enlarged to aid front, back and side to side adjustment.

(1) If hood is low in relation to cowl panel, insert shims between hinge and hood.

(2) Adjust hood bumper in or out to adjust hood-to-fender height alignment.

(3) Adjust the hood latch as necessary. Tighten the nuts to 11N·m (8 ft. lbs.).

(4) Align the latch striker so that striker enters the latch squarely and without binding.

DOOR ADJUSTMENT

Minor adjustment for alignment of the door is made by moving the latch striker.

IN AND OUT

(1) Loosen the latch striker.

(2) Tap the latch striker inward if the door character line is outboard of the body character line or tap the latch striker outward if the door character line is inboard of the body character line.

(3) Inspect the alignment. If correct, tighten striker to 28 N·m (21 ft. lbs.) .

UP AND DOWN

(1) Loosen the latch striker.

(2) Tap the latch striker downward if the door character line is higher than the body character line or tap the latch striker upward if the door character line is lower than the body character line.

(3) Inspect the alignment. If correct, tighten to 28 N·m (21 ft. lbs.).

DOOR LATCH**DOOR LATCH ADJUSTMENT**

(1) Locate access hole (Fig. 81).

(2) Insert a 5/32-inch hex-wrench through hole and into adjustment screw. Loosen screw.

(3) Operate outside handle button several times to release any restriction because of mis-alignment.

(4) Tighten adjustment screw to 3 N·m (30 in-lbs) torque.

(5) Test handle button and lock cylinder for proper operation.

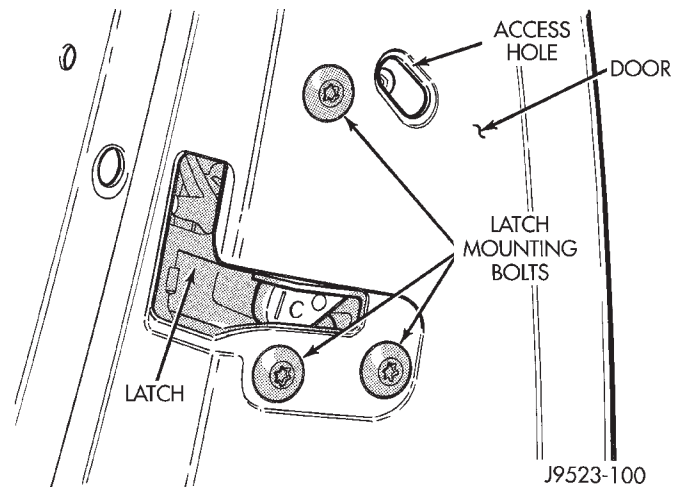

Fig. 81 Door Latch Adjustment

LIFTGATE ADJUSTMENT

The position of the liftgate can be adjusted upward or downward by the use of slots in the hinge. An inward or outward adjustment is achieved by use of slots in the body. If an inward or outward adjustment is needed, use 3M™ Fast and Firm or equivalent on the hinge to body mating surface as a sealant.

SPECIFICATIONS

BODY LUBRICANTS

COMPONENT	SERVICE INTERVAL	LUBRICANT
Door Hinges	As Required	Multi-Purpose Grease NLGI GC-LB (Water Resistant) (1)
Door Latches	As Required	Multi-Purpose Grease NLGI GC-LB (Water Resistant) (1)
Hood Latch, Release Mechanism and Safety Latch	As Required (When Performing Other Underhood Service)	Multi-Purpose Grease NLGI GC-LB 2 EP (2)
Hood Hinges	As Required	Engine Oil
Seat Track and Release Mechanism	As Required	Multi-Purpose Grease NLGI GC-LB 2 EP (2)
Liftgate Hinge	As Required	Multi-Purpose Grease NLGI GC-LB 2 EP (2)
Liftgate Support Arms	As Required	Engine Oil
Liftgate Latches	As Required	White Spray Lubricant (3)
Liftgate Release Handle (Pivot and Slide Contact Surfaces)	As Required	Multi-Purpose Grease NLGI GC-LB 2 EP (2)
Window System Components	As Required	White Spray Lubricant (3)
Lock Cylinders	Twice a Year	Lock-Cylinder Lubricant (4)
Parking Brake Mechanism	As Required	Multi-Purpose Grease NLGI GC-LB 2 EP (1)
1 = Mopar Wheel Bearing Grease (High Temp) 2 = Mopar Multi-Mileage Lubricant 3 = Mopar Spray White Lube 4 = Mopar Lock Cylinder Lubricant		

SPECIFICATIONS (Continued)

WELD LOCATIONS

RADIATOR SUPPORT BRACKETS

W2 - WELDING OF 2 PARTS
W3 - WELDING OF 3 PARTS
W4 - WELDING OF 4 PARTS

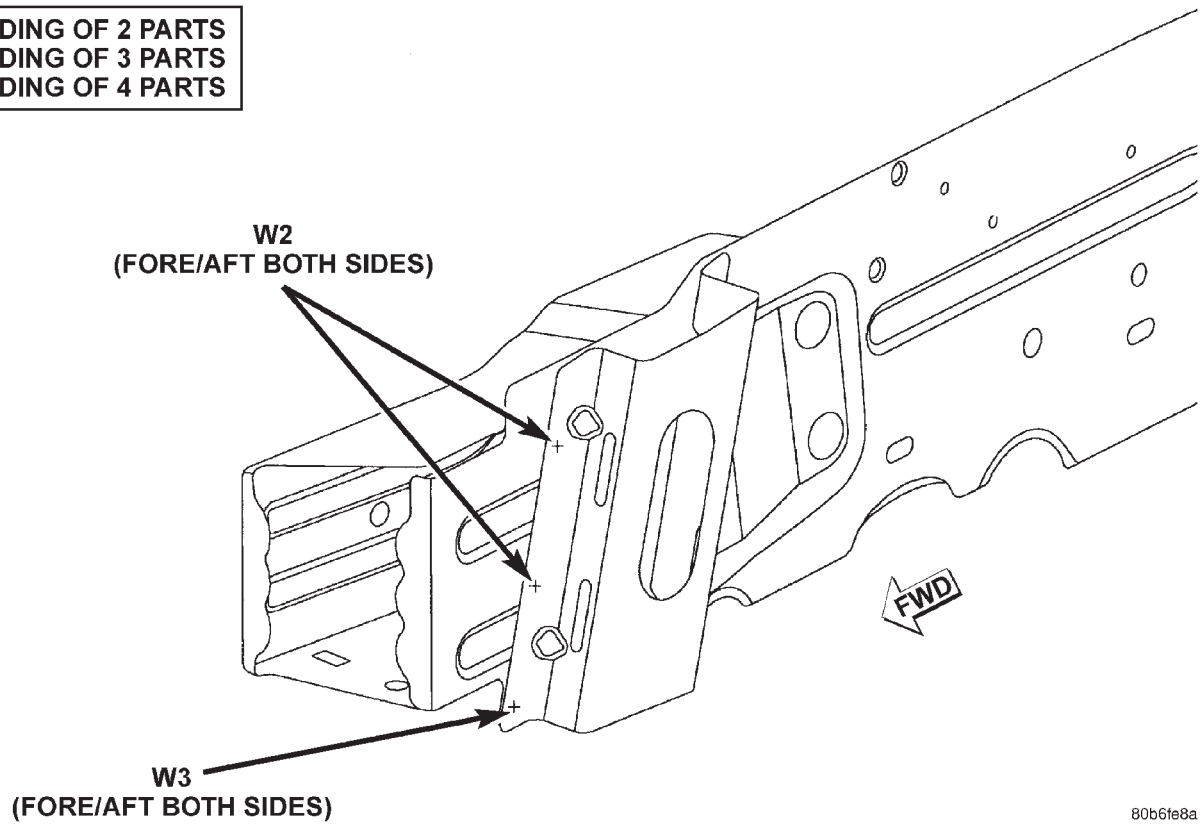

80b6fe8a

SPECIFICATIONS (Continued)

FRONT SUSPENSION SUPPORT REINFORCEMENT

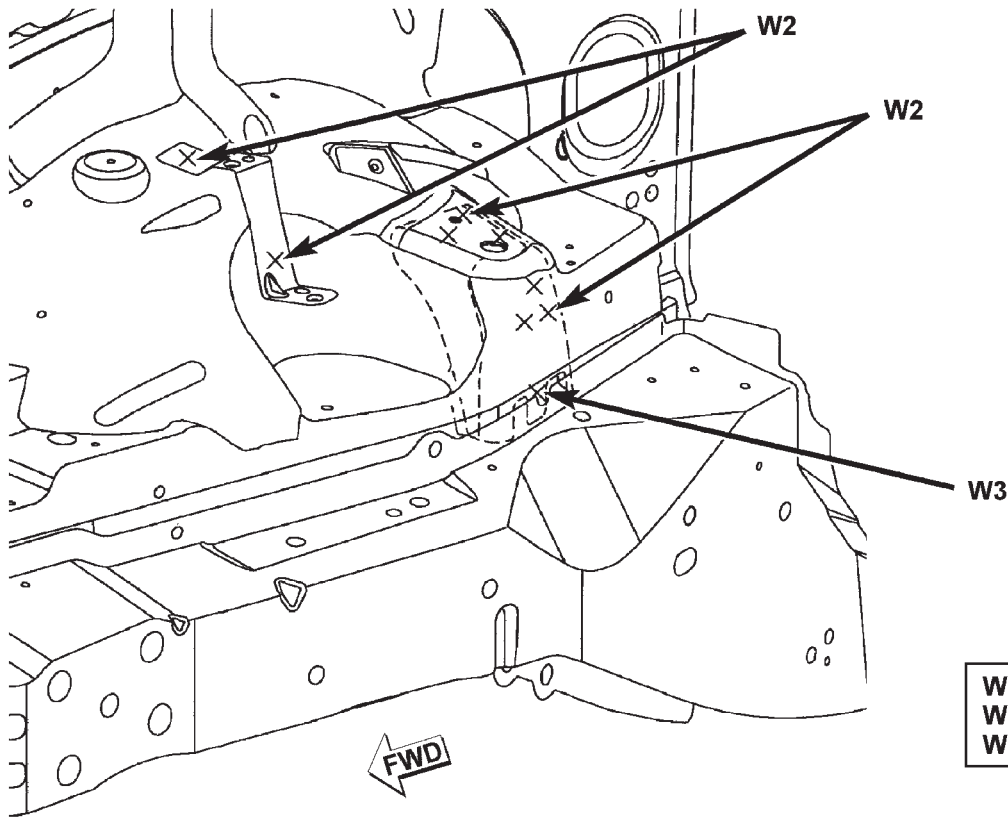

W2 - WELDING OF 2 PARTS
W3 - WELDING OF 3 PARTS
W4 - WELDING OF 4 PARTS

SPECIFICATIONS (Continued)

FRONT LOWER CROSSMEMBER TO COWL SIDE PANEL

W2 - WELDING OF 2 PARTS
W3 - WELDING OF 3 PARTS
W4 - WELDING OF 4 PARTS

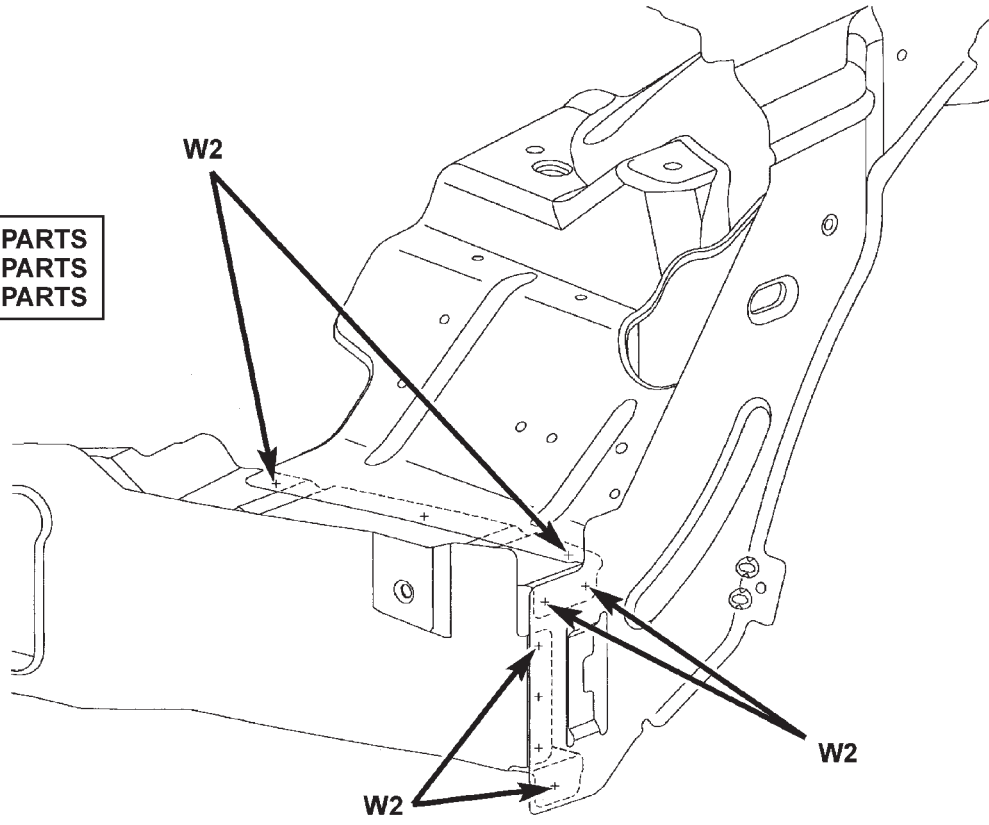

80b6fe8c

SPECIFICATIONS (Continued)

FRONT SILL TO LOWER CROSSMEMBER

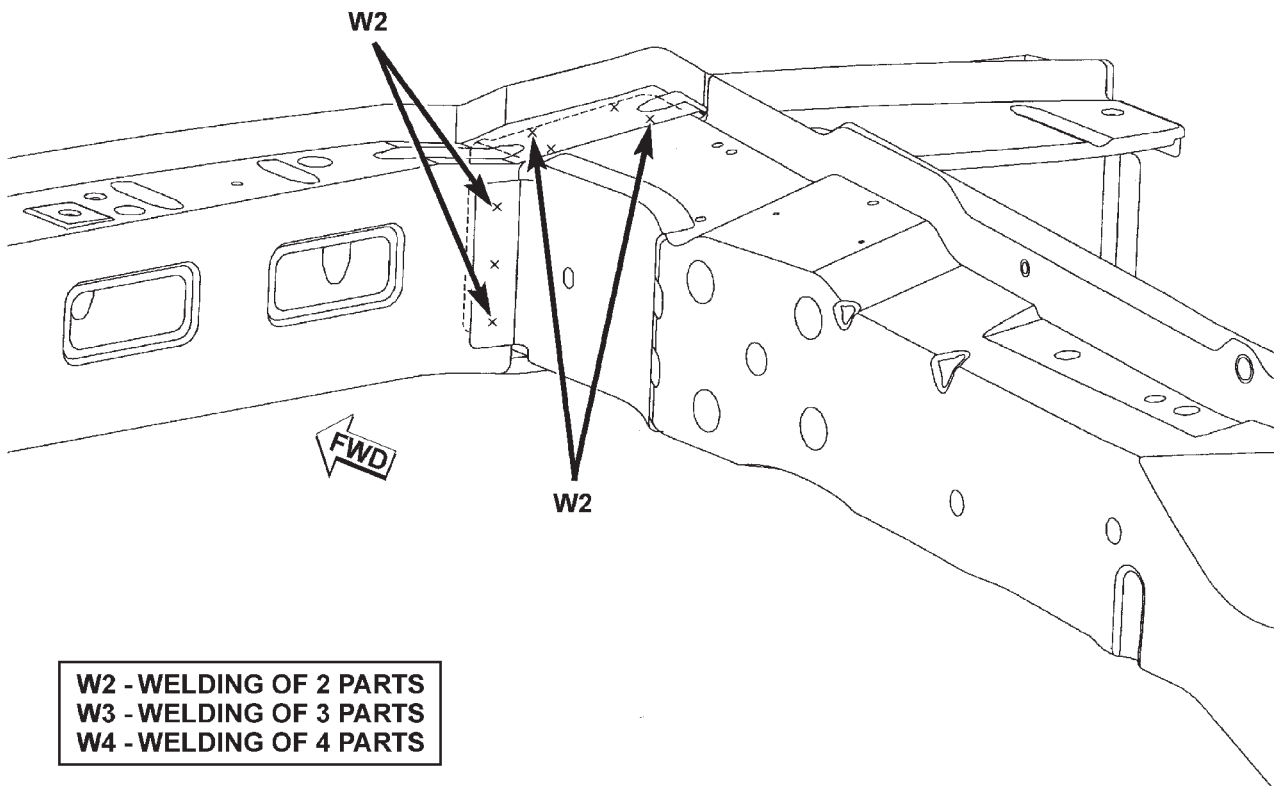
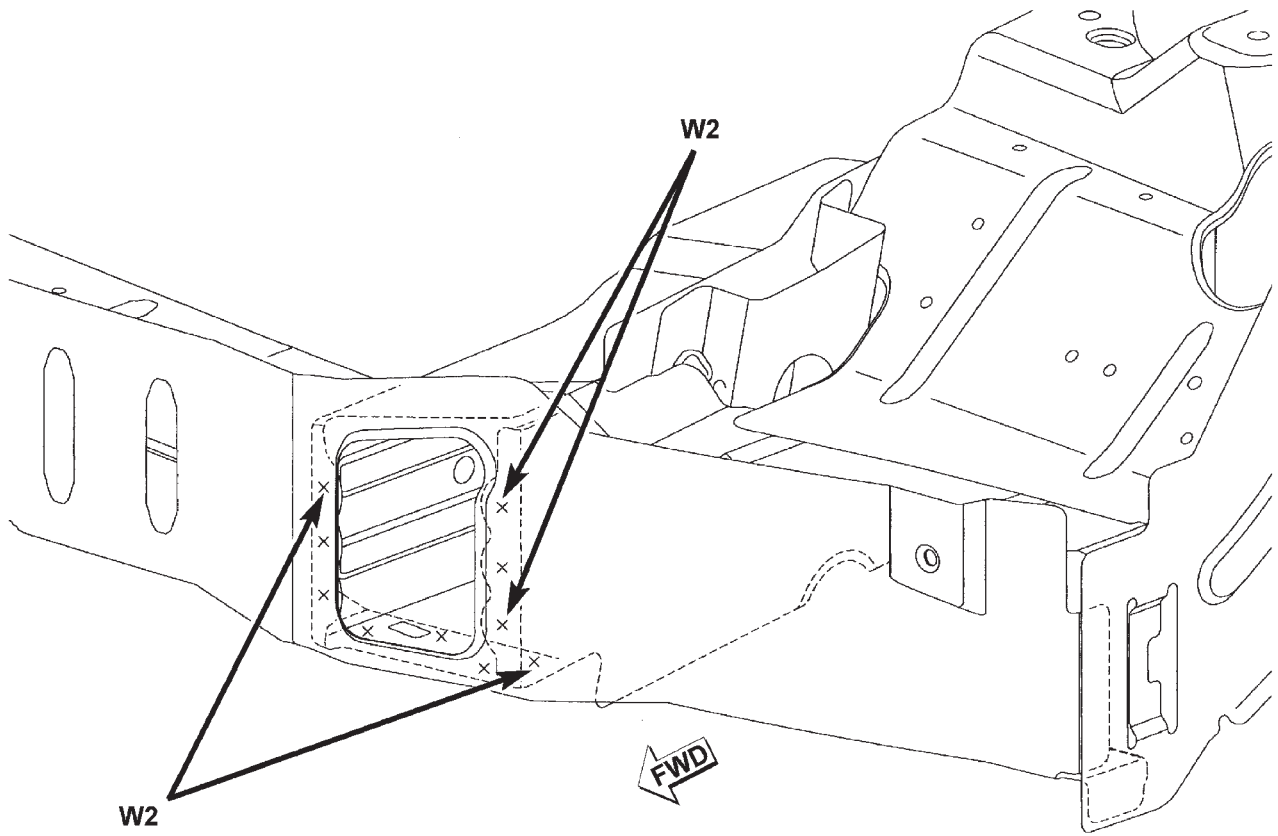

W2 - WELDING OF 2 PARTS
W3 - WELDING OF 3 PARTS
W4 - WELDING OF 4 PARTS

SPECIFICATIONS (Continued)

FRONT FENDER MOUNTING BRACKET AND REINFORCEMENT

W2 - WELDING OF 2 PARTS
W3 - WELDING OF 3 PARTS
W4 - WELDING OF 4 PARTS

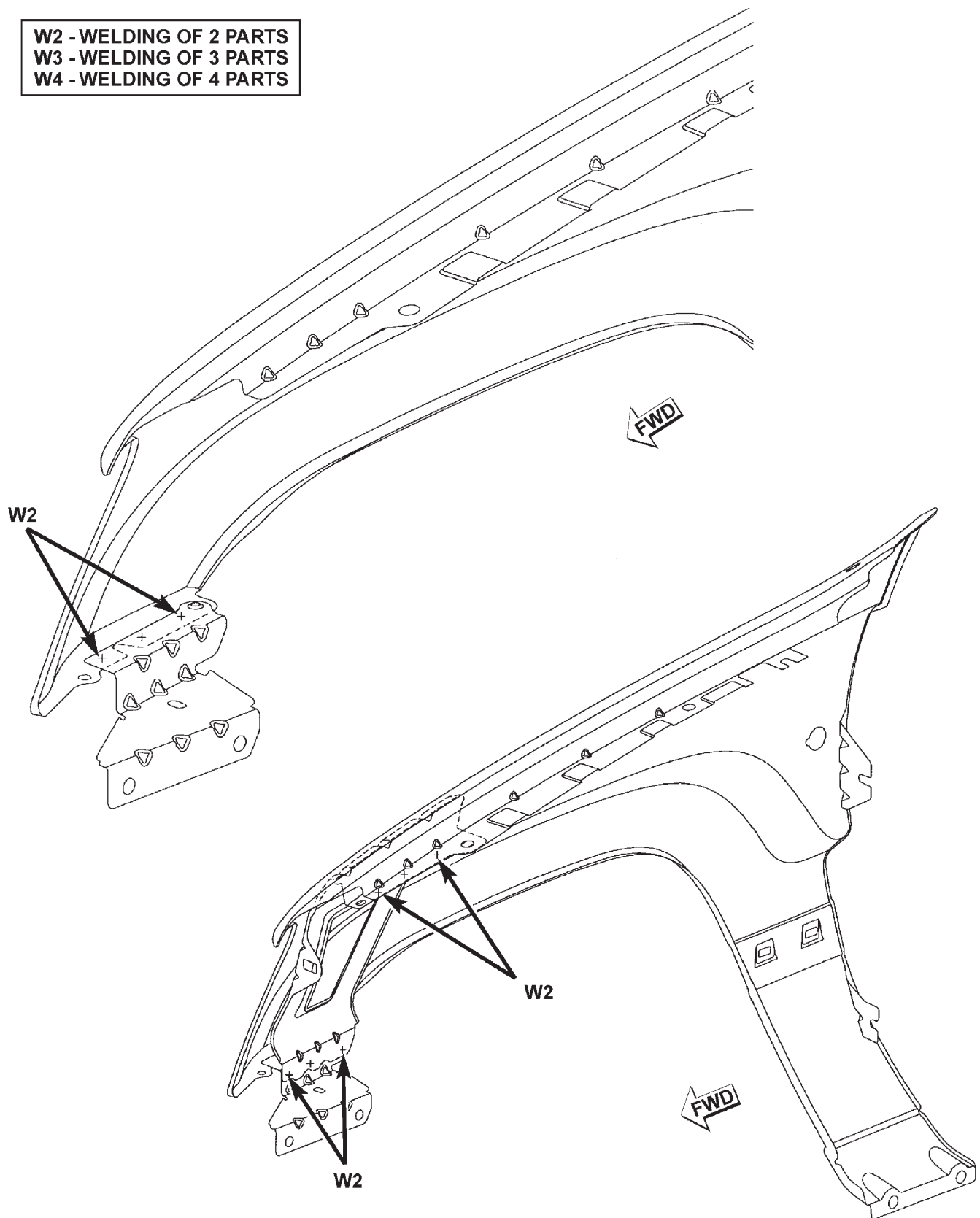

SPECIFICATIONS (Continued)

FRONT SUSPENSION SUPPORT TO SILLS AND COWL SIDE PANEL

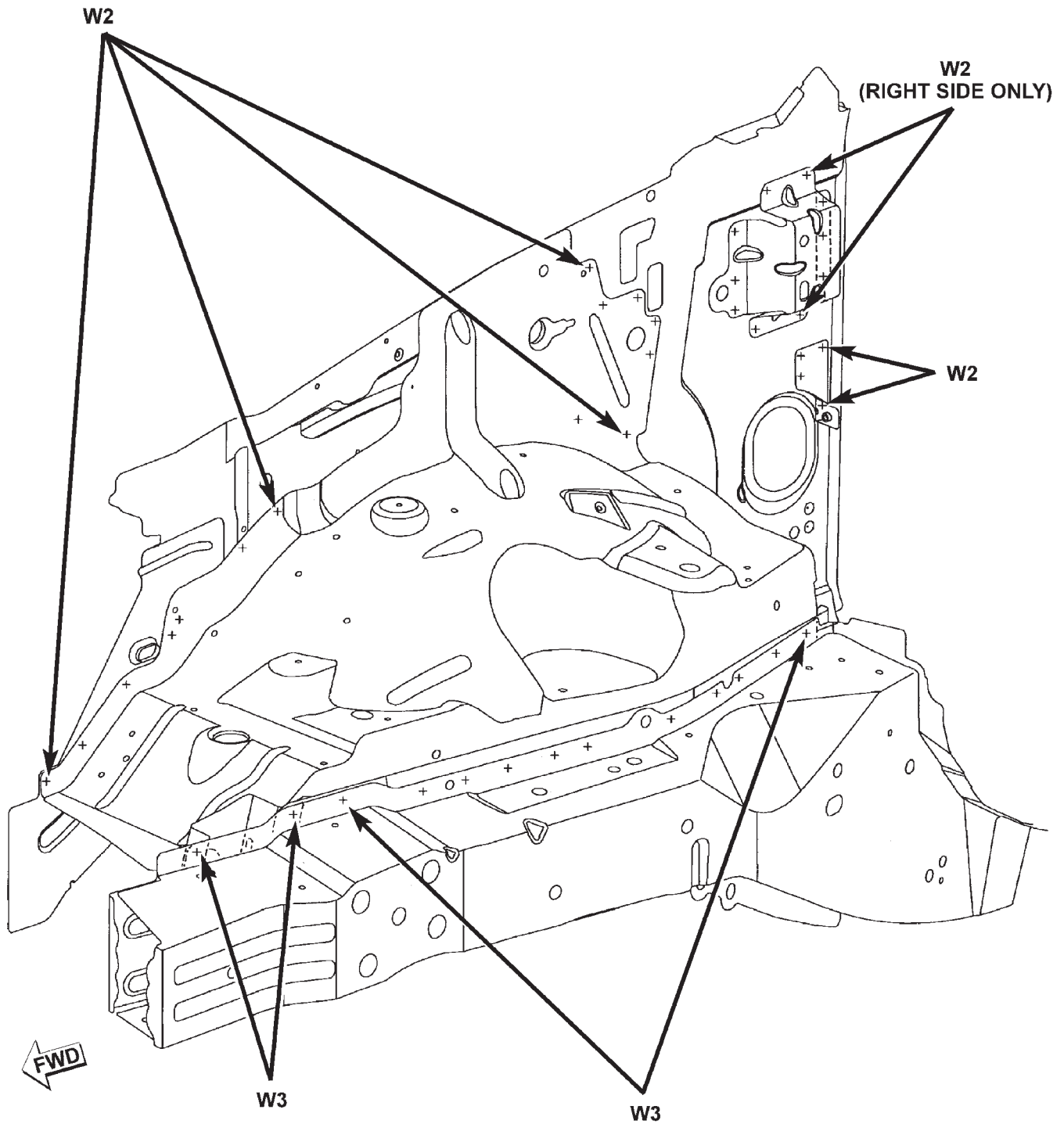

W2 - WELDING OF 2 PARTS
W3 - WELDING OF 3 PARTS
W4 - WELDING OF 4 PARTS

SPECIFICATIONS (Continued)

LEFT INSTRUMENT PANEL BRACKET TO COWL
SIDE PANEL

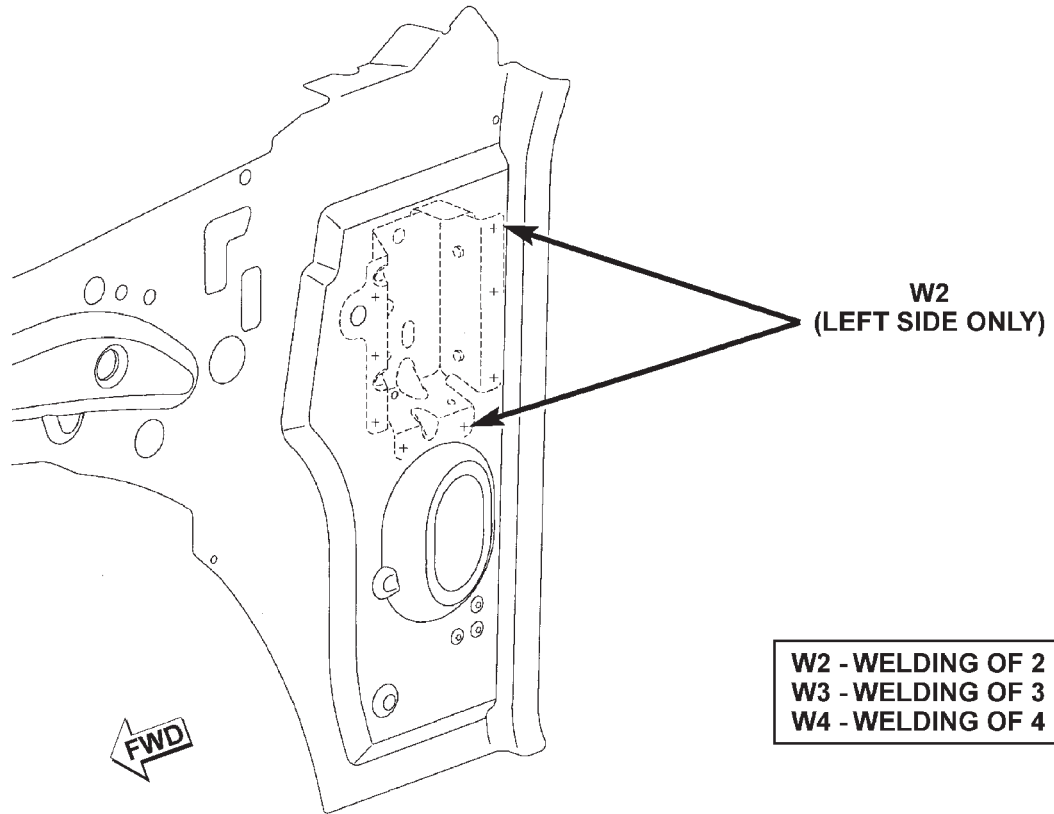

W2 - WELDING OF 2 PARTS
W3 - WELDING OF 3 PARTS
W4 - WELDING OF 4 PARTS

SPECIFICATIONS (Continued)

COWL SIDE UPPER REINFORCEMENT TO COWL SIDE AND FRONT SUSPENSION SUPPORT

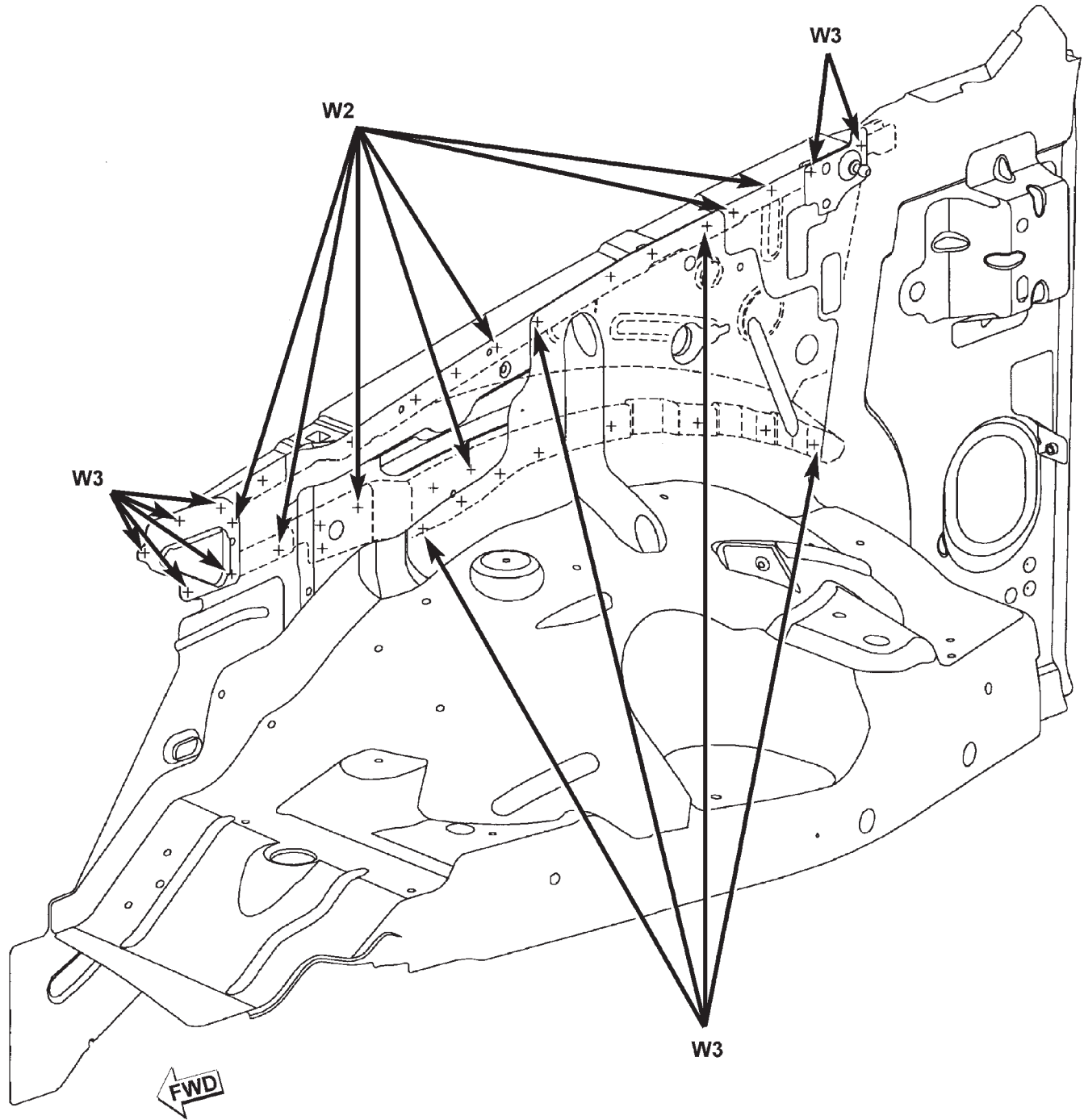

W2 - WELDING OF 2 PARTS
W3 - WELDING OF 3 PARTS
W4 - WELDING OF 4 PARTS

SPECIFICATIONS (Continued)

COWL SIDE PANEL TO DASH PANEL AND INNER BODYSIDE PANEL AND SILL

W2 - WELDING OF 2 PARTS
W3 - WELDING OF 3 PARTS
W4 - WELDING OF 4 PARTS

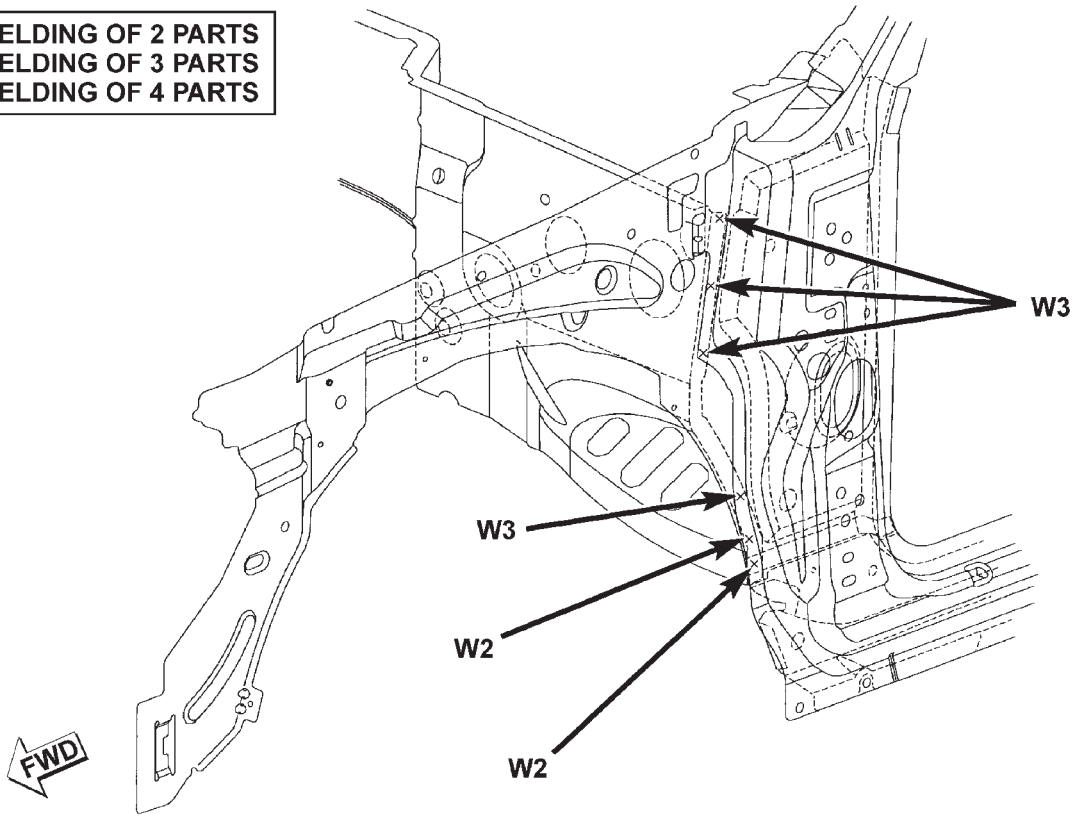

SPECIFICATIONS (Continued)

PLENUM ASSEMBLY TO COWL SIDE PANEL

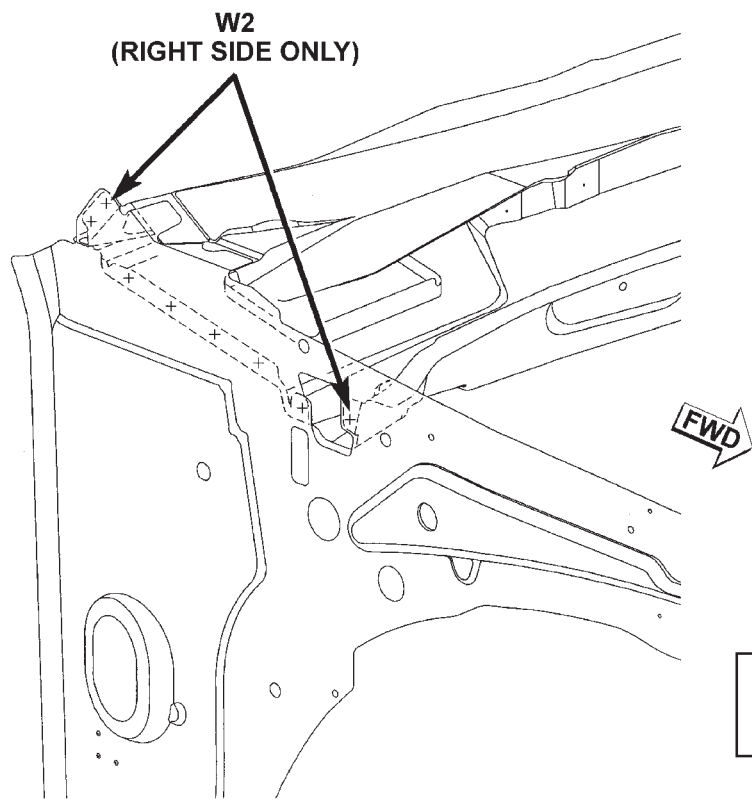

W2 - WELDING OF 2 PARTS
W3 - WELDING OF 3 PARTS
W4 - WELDING OF 4 PARTS

SPECIFICATIONS (Continued)

FRONT LOWER CROSSMEMBER

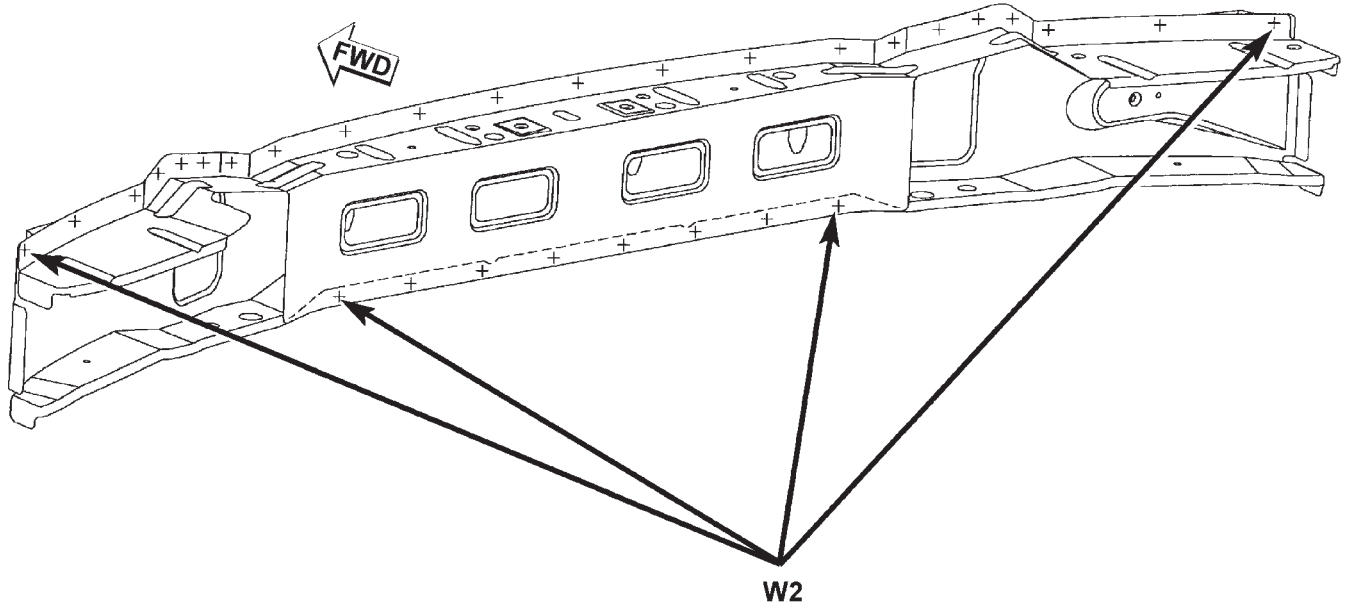

W2 - WELDING OF 2 PARTS
W3 - WELDING OF 3 PARTS
W4 - WELDING OF 4 PARTS

SPECIFICATIONS (Continued)

FRONT SUSPENSION SUPPORT TO DASH

W2 - WELDING OF 2 PARTS
W3 - WELDING OF 3 PARTS
W4 - WELDING OF 4 PARTS

RIGHT SIDE ONLY

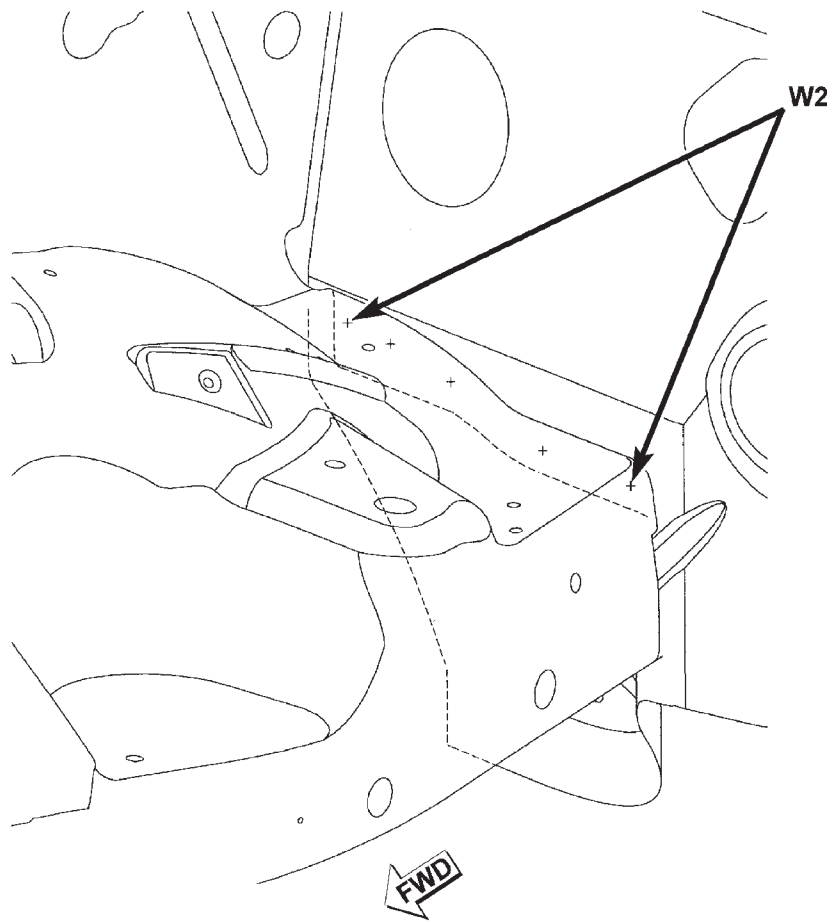

LEFT SIDE ONLY

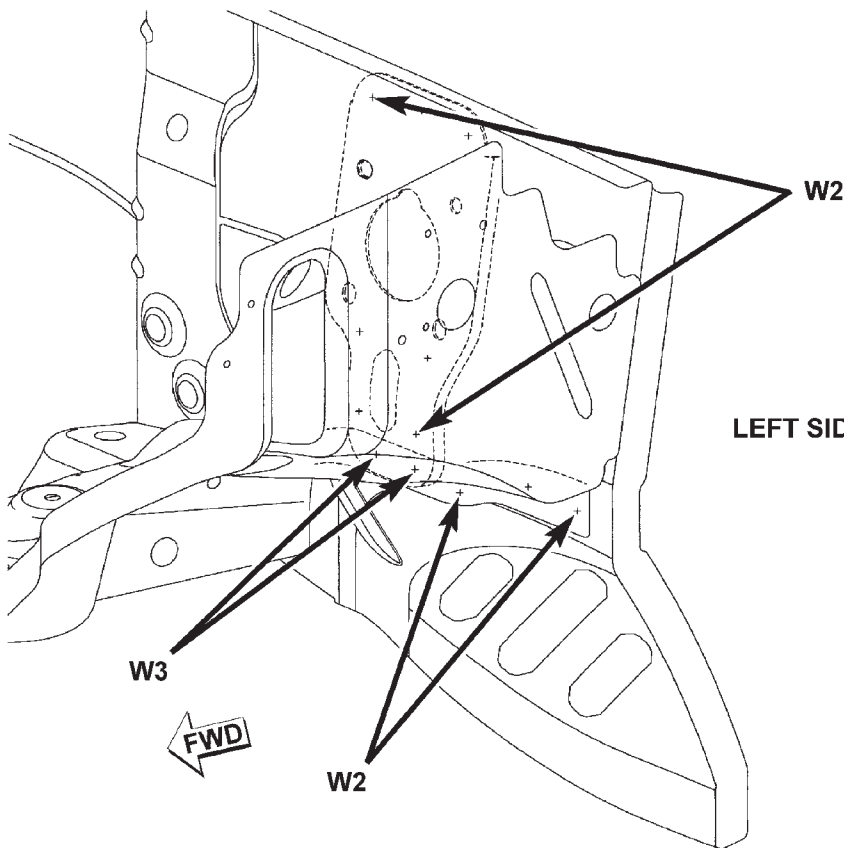

SPECIFICATIONS (Continued)

WIPER MOUNTING BRACKETS TO PLENUM ASSEMBLY

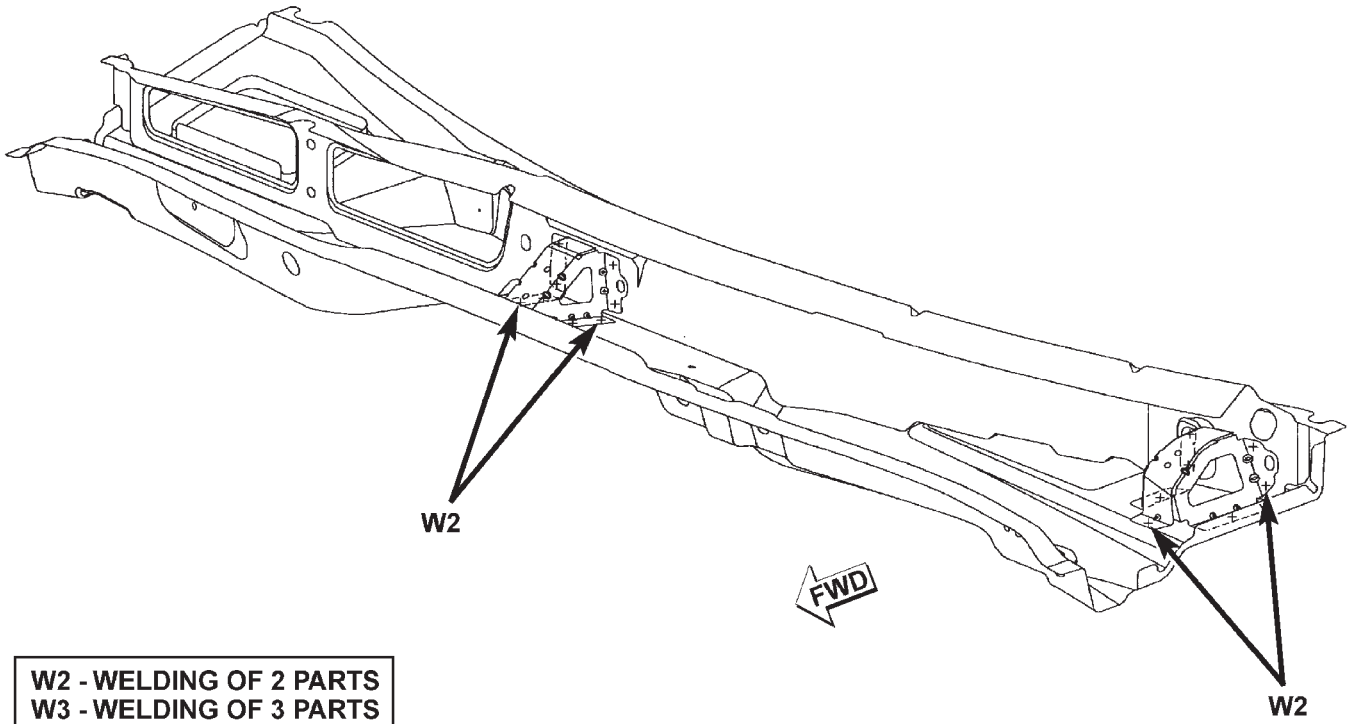

W2 - WELDING OF 2 PARTS
W3 - WELDING OF 3 PARTS
W4 - WELDING OF 4 PARTS

SPECIFICATIONS (Continued)

COWL TOP AND PLENUM ASSEMBLY

W2 - WELDING OF 2 PARTS
W3 - WELDING OF 3 PARTS
W4 - WELDING OF 4 PARTS

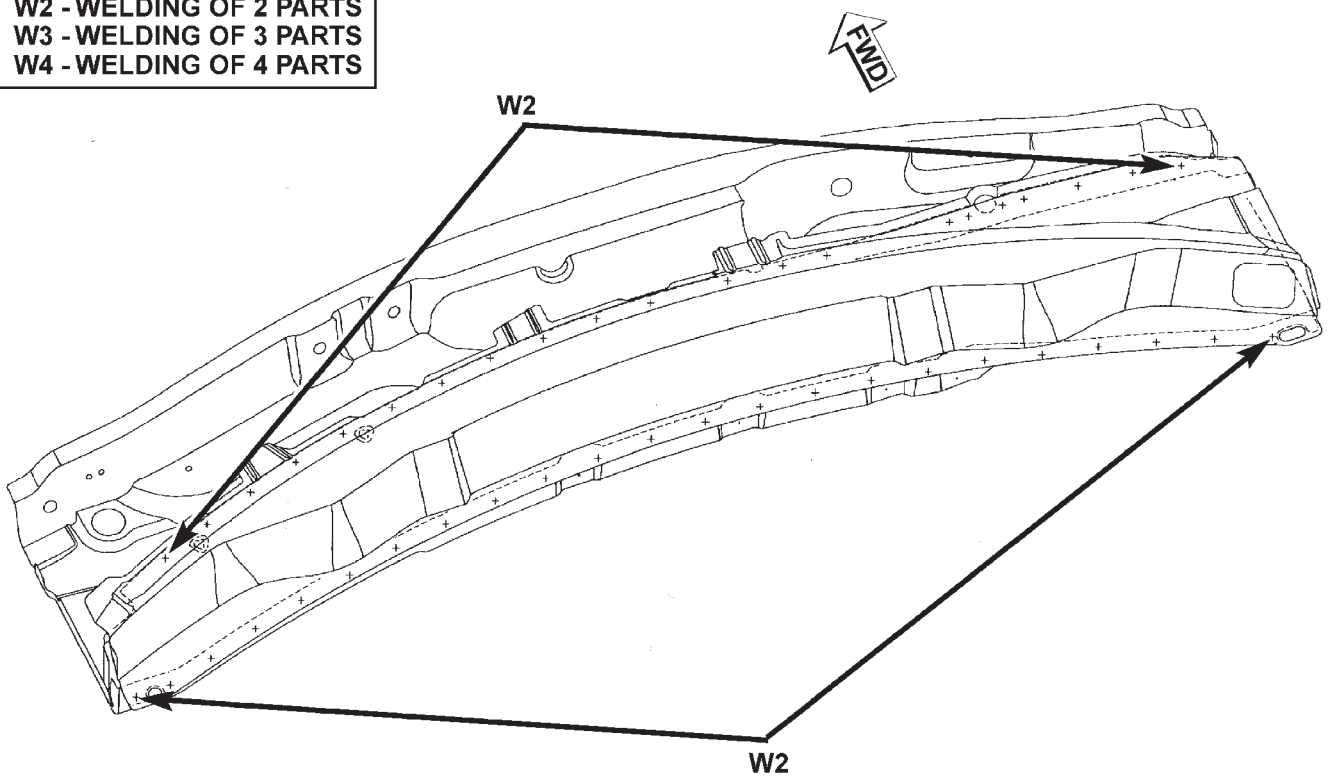

SPECIFICATIONS (Continued)

LOWER PLENUM REINFORCEMENT TO LOWER
PLENUM PANEL

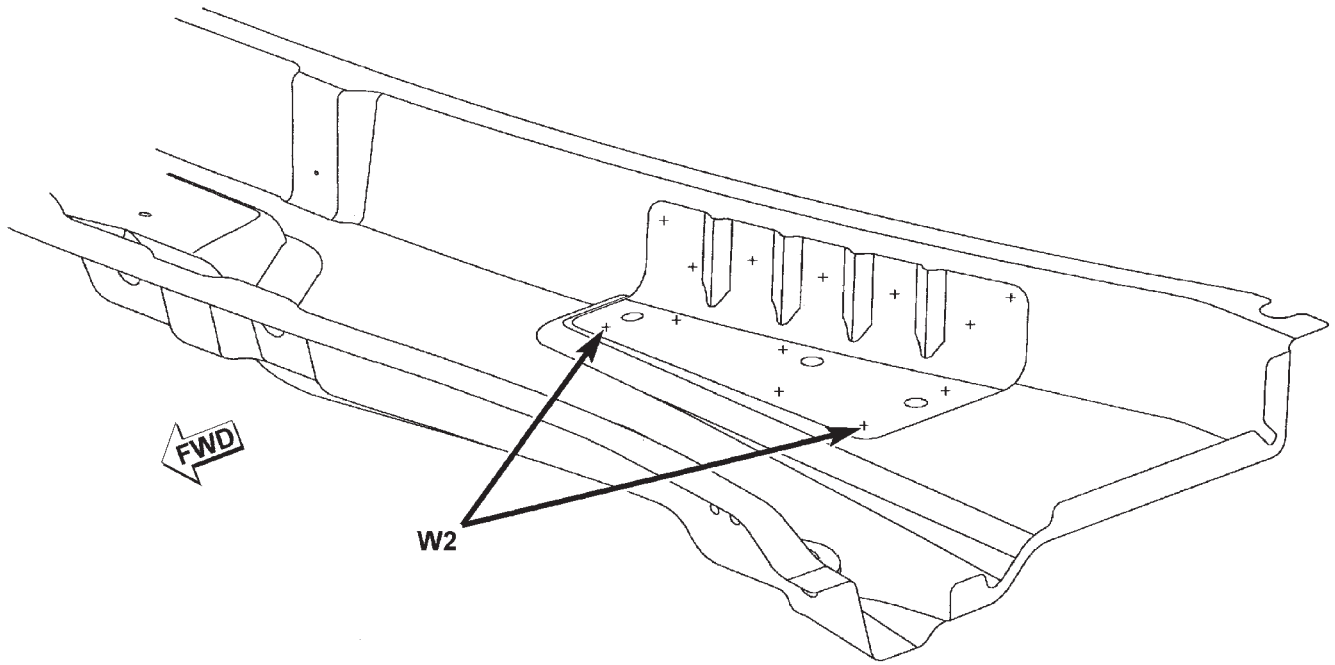

W2 - WELDING OF 2 PARTS
W3 - WELDING OF 3 PARTS
W4 - WELDING OF 4 PARTS

SPECIFICATIONS (Continued)

DASH PANEL TO LOWER PLENUM PANEL

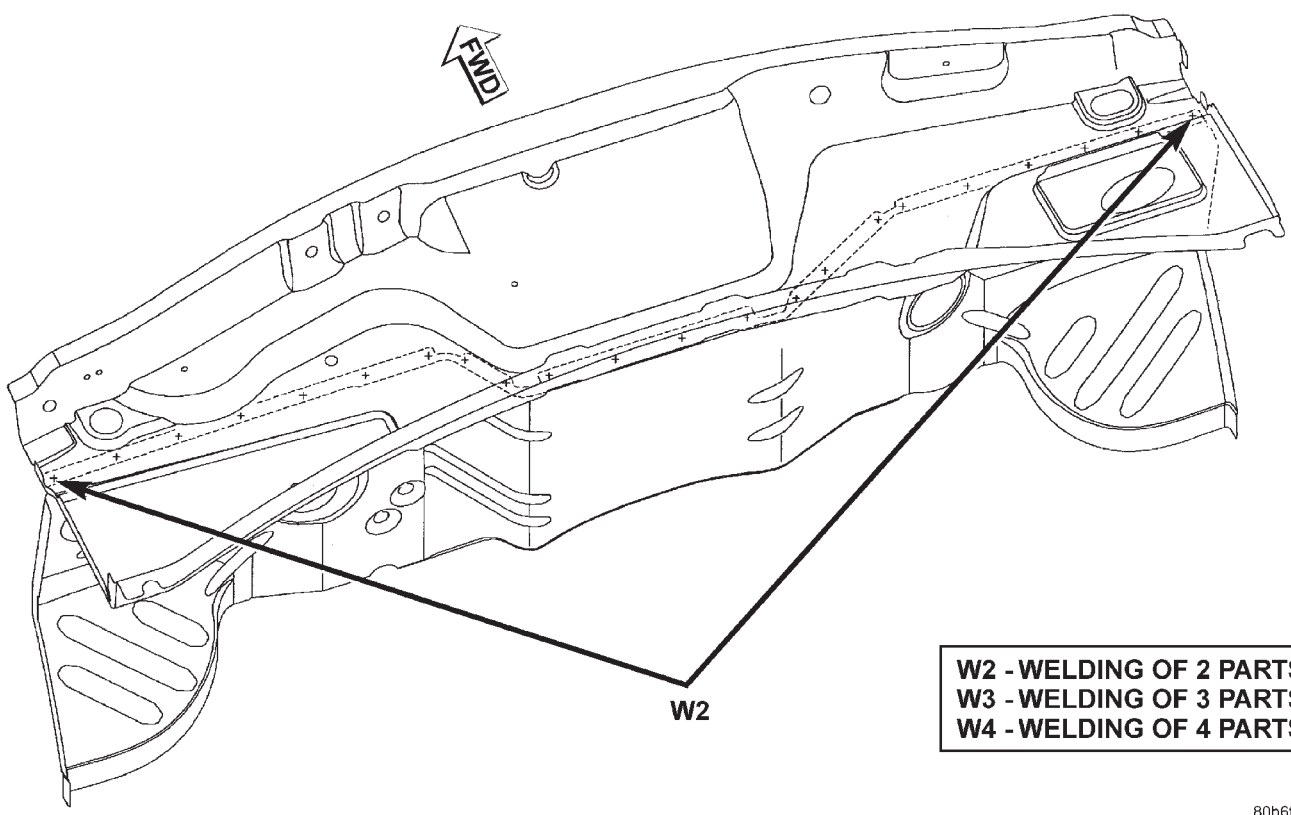

SPECIFICATIONS (Continued)

PLENUM ASSEMBLY TO COWL

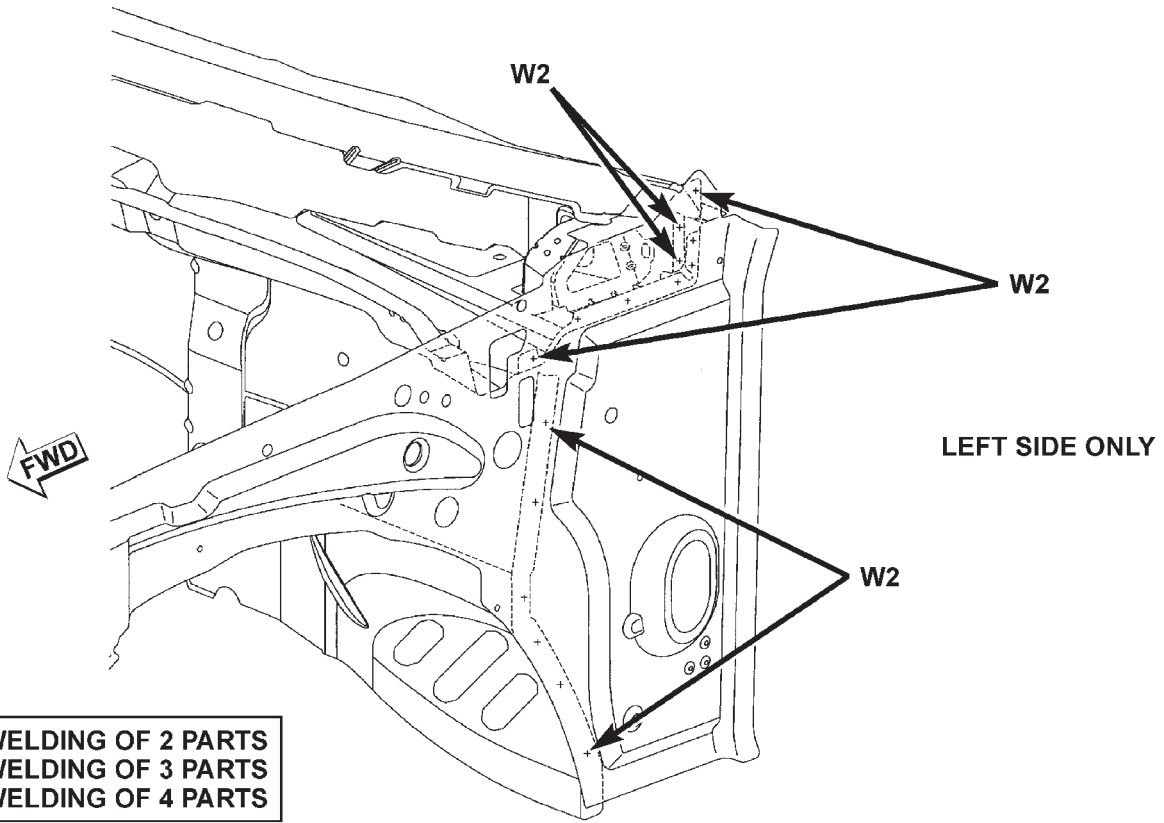

W2 - WELDING OF 2 PARTS
W3 - WELDING OF 3 PARTS
W4 - WELDING OF 4 PARTS

SPECIFICATIONS (Continued)

COWL PANEL TO BODYSIDE SILL

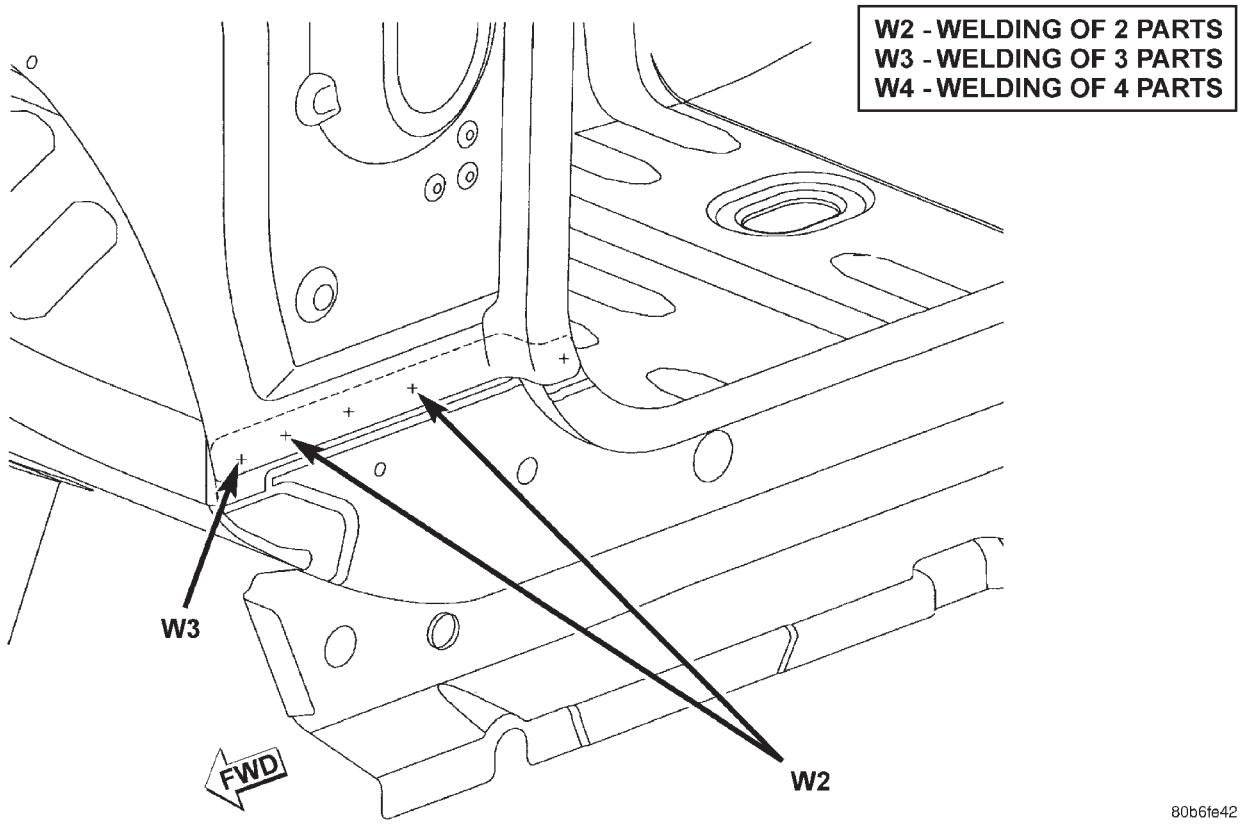

SPECIFICATIONS (Continued)

COWL PANEL TO FRONT FLOOR PAN

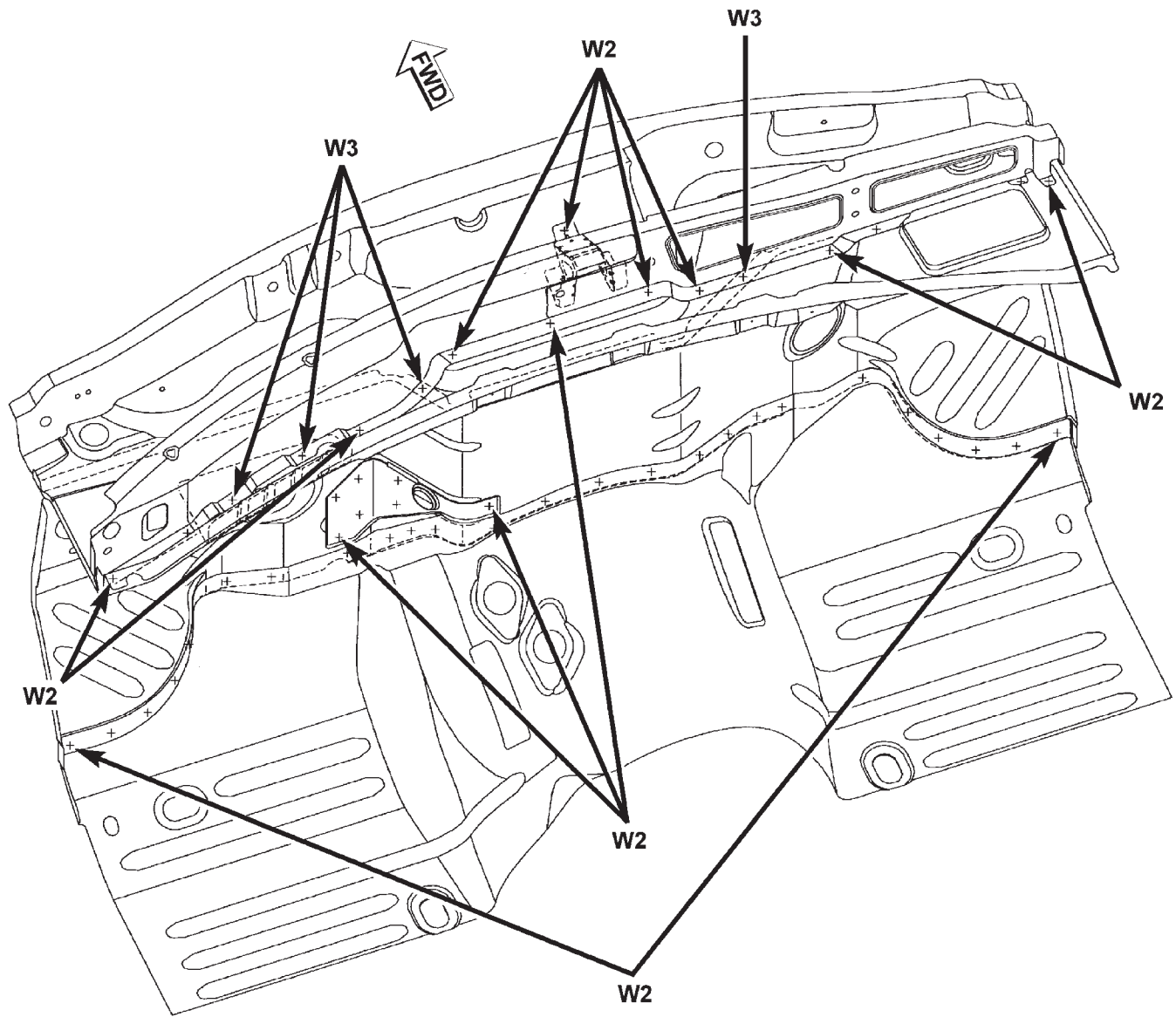

W2 - WELDING OF 2 PARTS
W3 - WELDING OF 3 PARTS
W4 - WELDING OF 4 PARTS

SPECIFICATIONS (Continued)

FRONT SILLS TO DASH AND FRONT FLOOR PAN

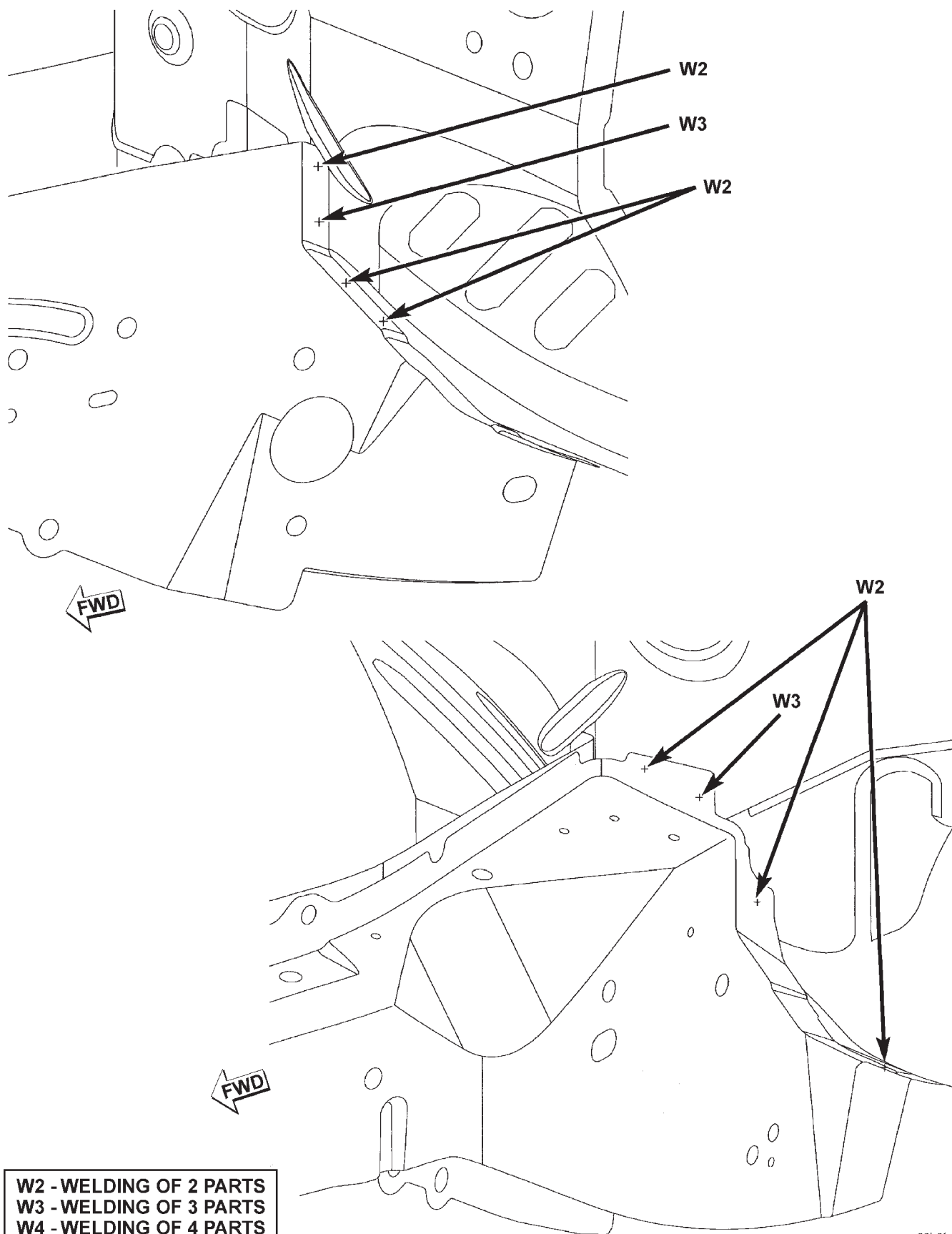

W2 - WELDING OF 2 PARTS
W3 - WELDING OF 3 PARTS
W4 - WELDING OF 4 PARTS

SPECIFICATIONS (Continued)

COWL SIDE PANEL DASH INNER BODYSIDE AND OUTER BODYSIDE PANELS

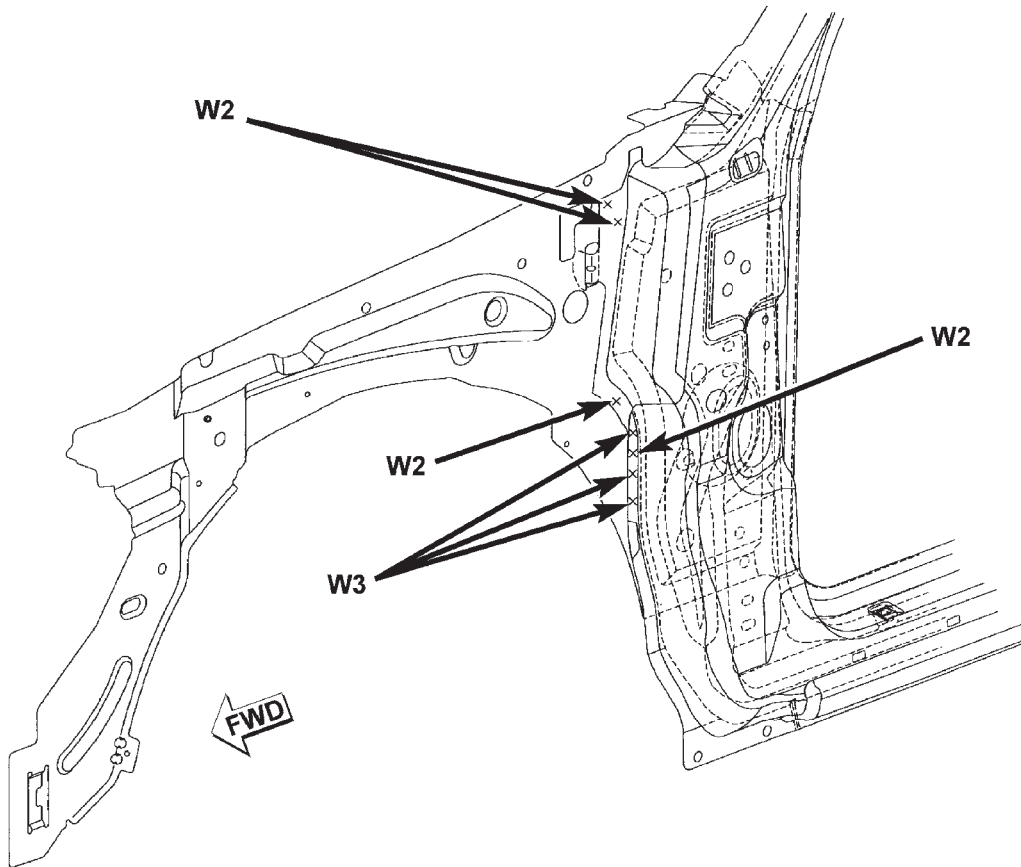

W2 - WELDING OF 2 PARTS
W3 - WELDING OF 3 PARTS
W4 - WELDING OF 4 PARTS

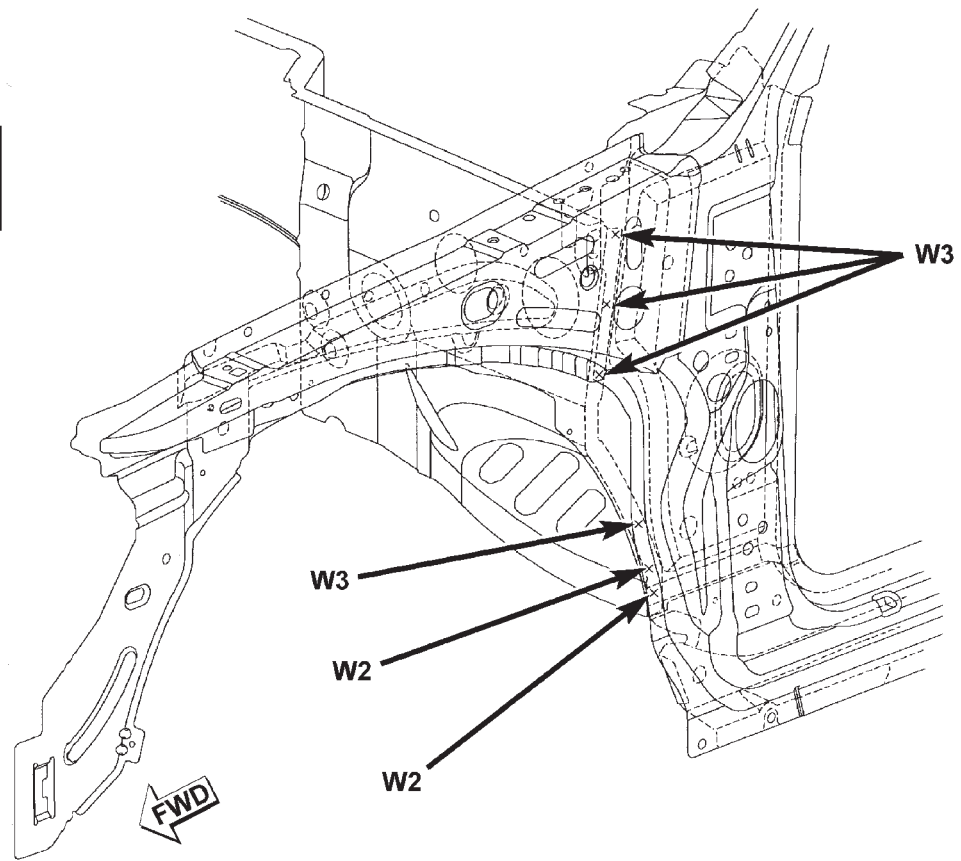

SPECIFICATIONS (Continued)

UPPER FRONT INNER PILLAR TO ROOF AND COWL

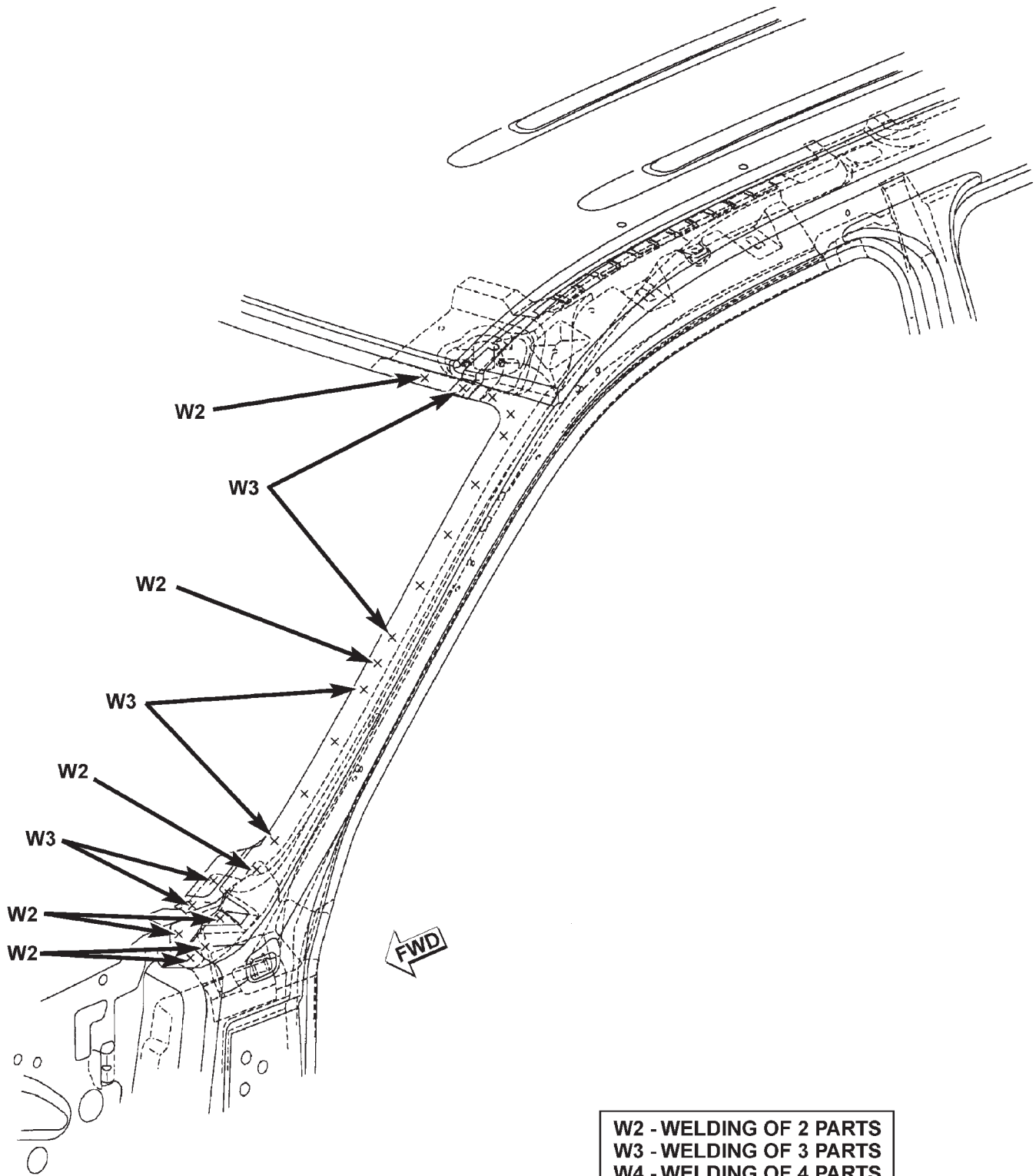

W2 - WELDING OF 2 PARTS
W3 - WELDING OF 3 PARTS
W4 - WELDING OF 4 PARTS

SPECIFICATIONS (Continued)

DOOR OPENINGS

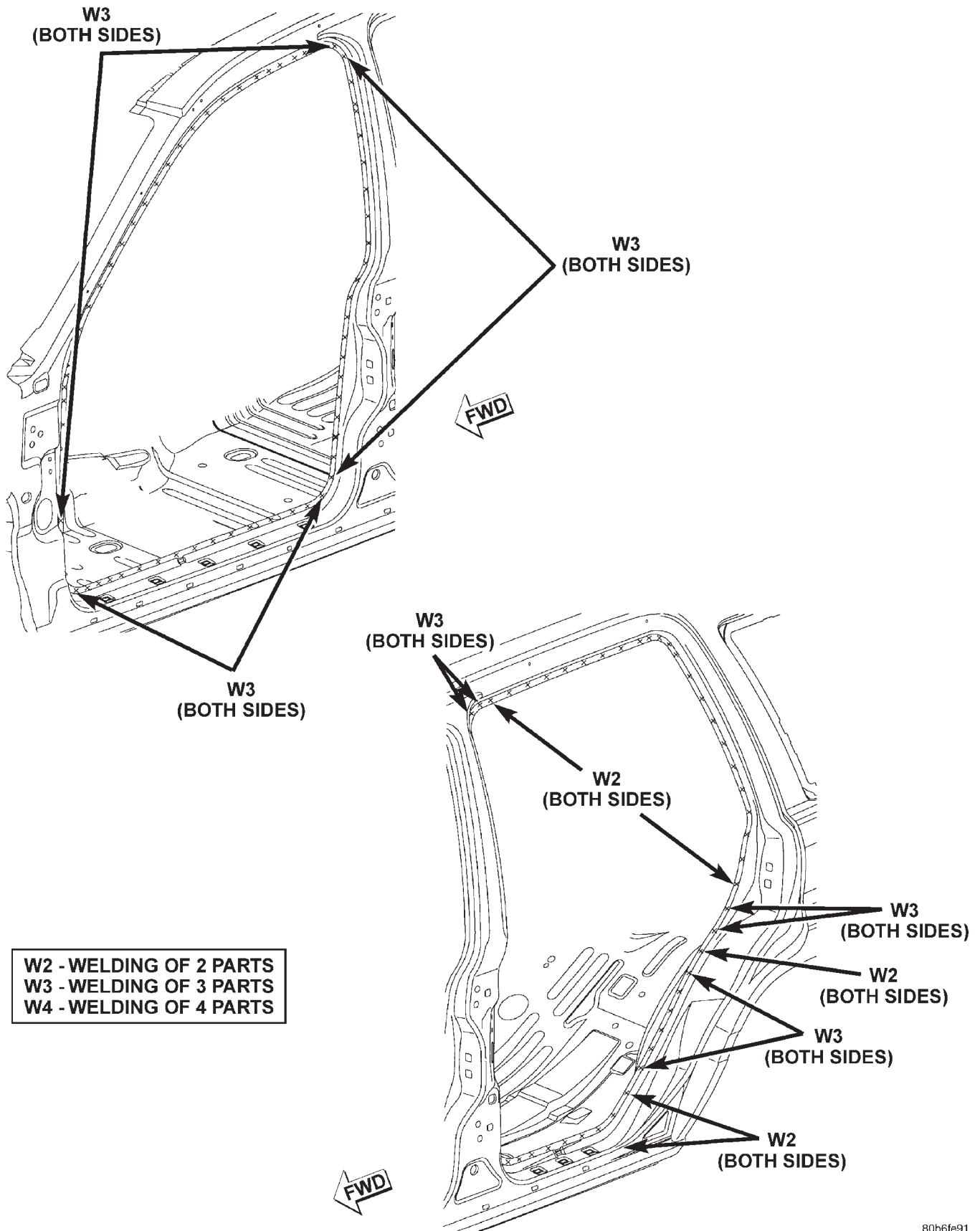

SPECIFICATIONS (Continued)

B-PILLAR REINFORCEMENT TO INNER BODYSIDE APERTURE

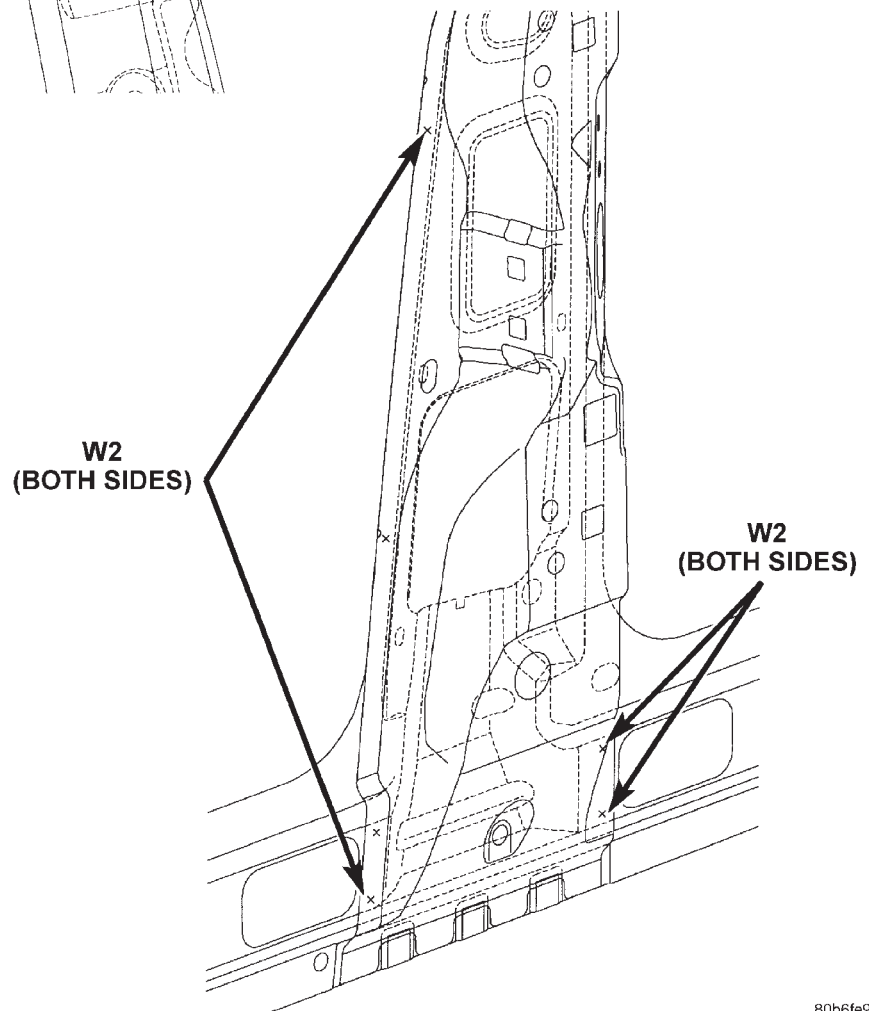
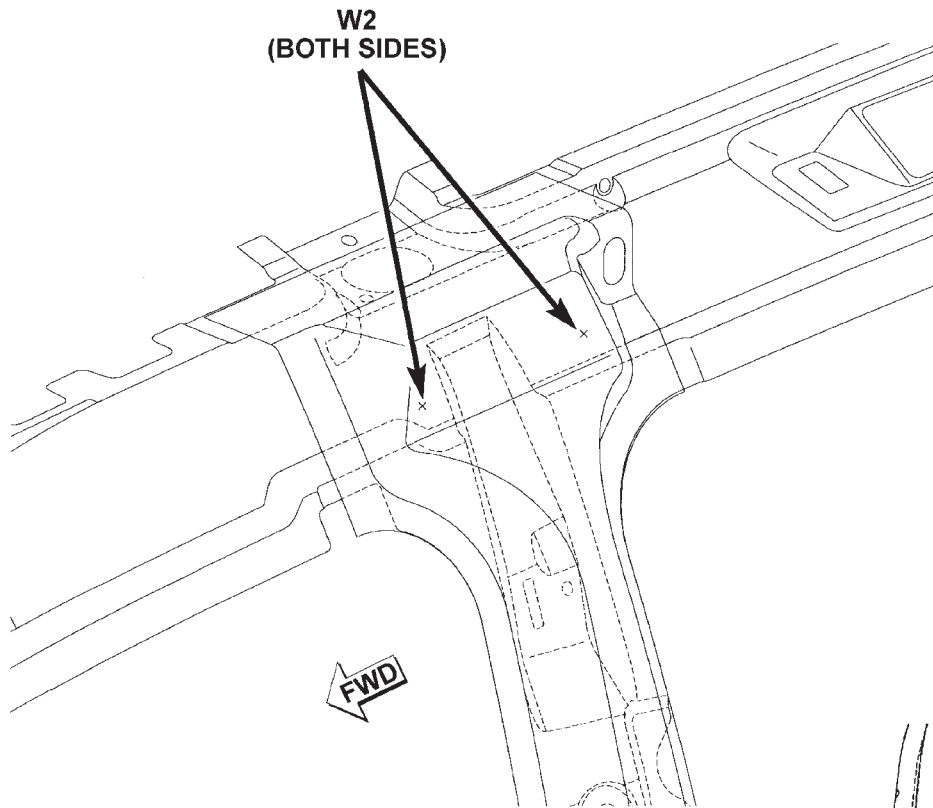

W2 - WELDING OF 2 PARTS
W3 - WELDING OF 3 PARTS
W4 - WELDING OF 4 PARTS

SPECIFICATIONS (Continued)

REAR QUARTER WINDOW TO BODYSIDE
APERTURE INNER AND OUTER

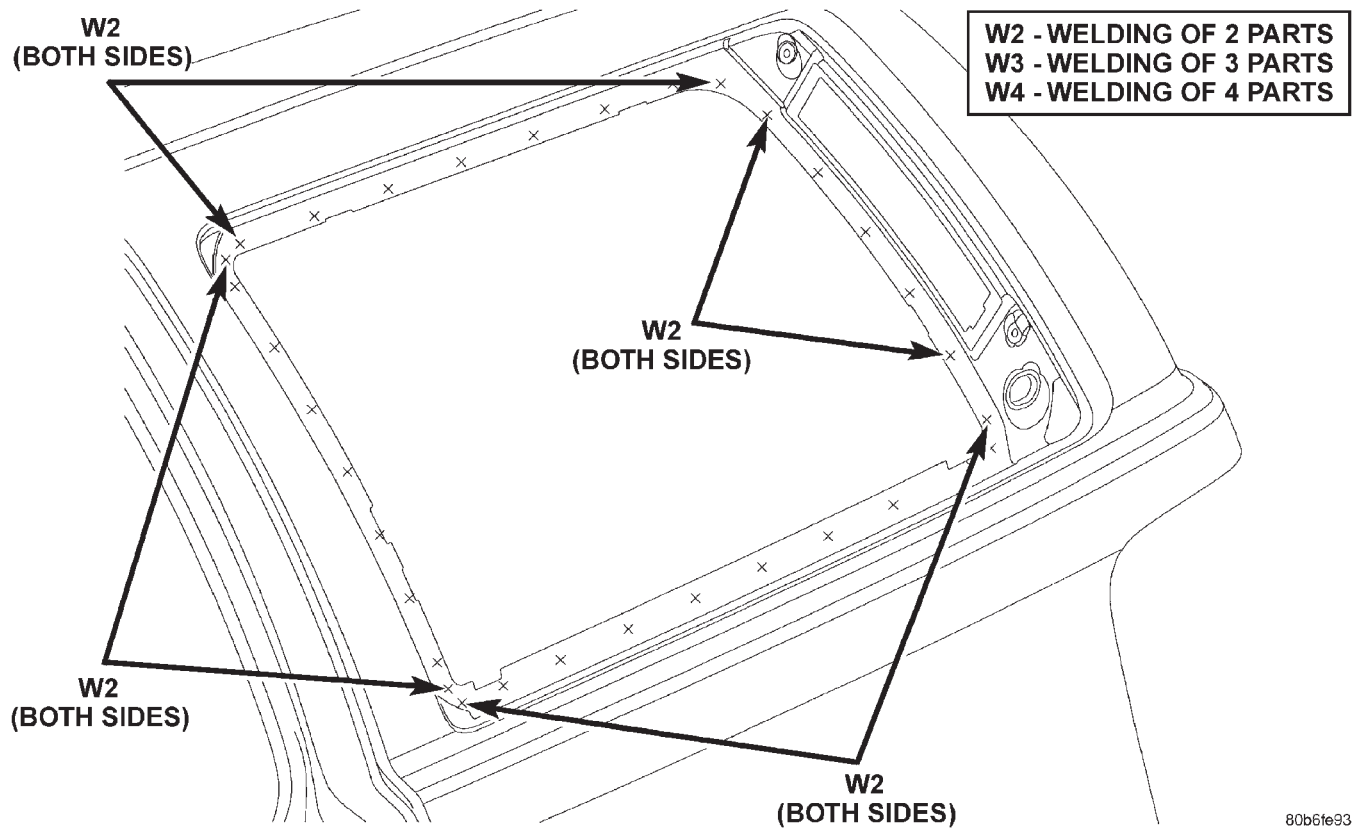

SPECIFICATIONS (Continued)

LOWER REAR QUARTER TO BODYSIDE APERTURE
INNER AND OUTER

W2 - WELDING OF 2 PARTS
W3 - WELDING OF 3 PARTS
W4 - WELDING OF 4 PARTS

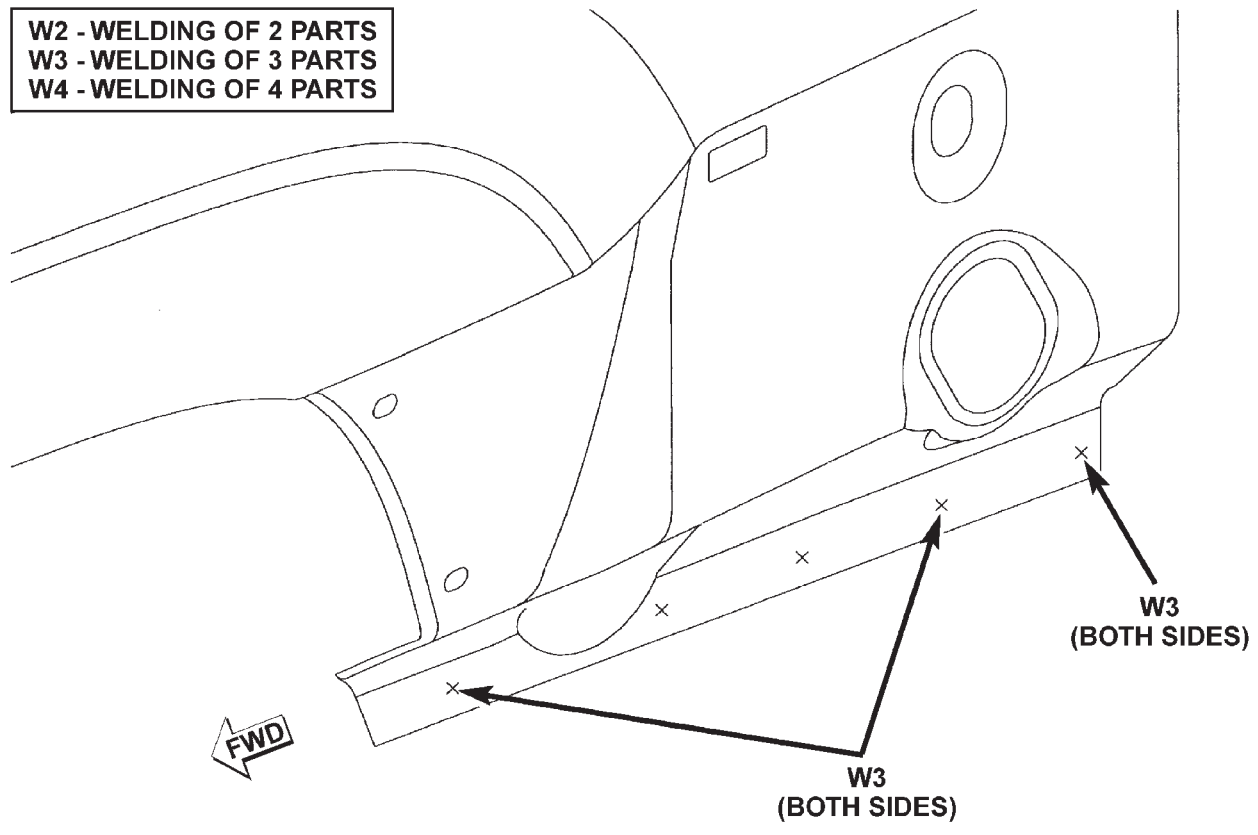

SPECIFICATIONS (Continued)

INNER TRACK BAR, LOWER CONTROL ARM AND TRANSMISSION CROSSMEMBER BRACKETS TO FRONT SILLS

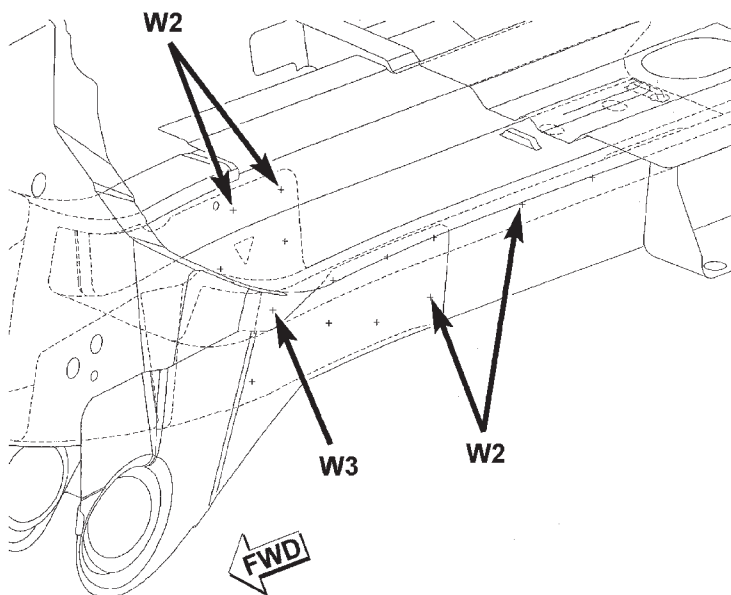
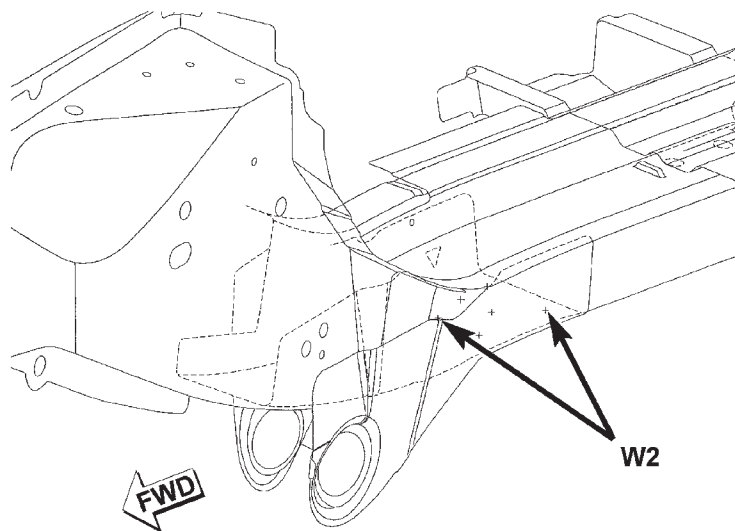
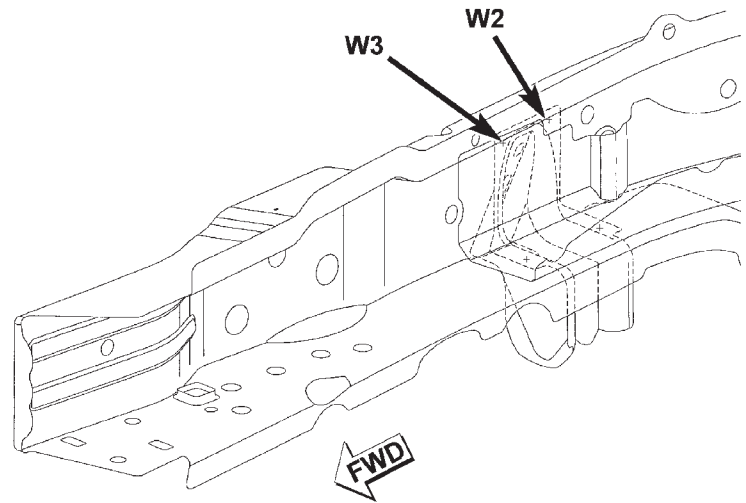

W2 - WELDING OF 2 PARTS
W3 - WELDING OF 3 PARTS
W4 - WELDING OF 4 PARTS

SPECIFICATIONS (Continued)

TRANSMISSION CROSSMEMBER BRACKET AND REINFORCEMENT TO FRONT SILLS

W2 - WELDING OF 2 PARTS
W3 - WELDING OF 3 PARTS
W4 - WELDING OF 4 PARTS

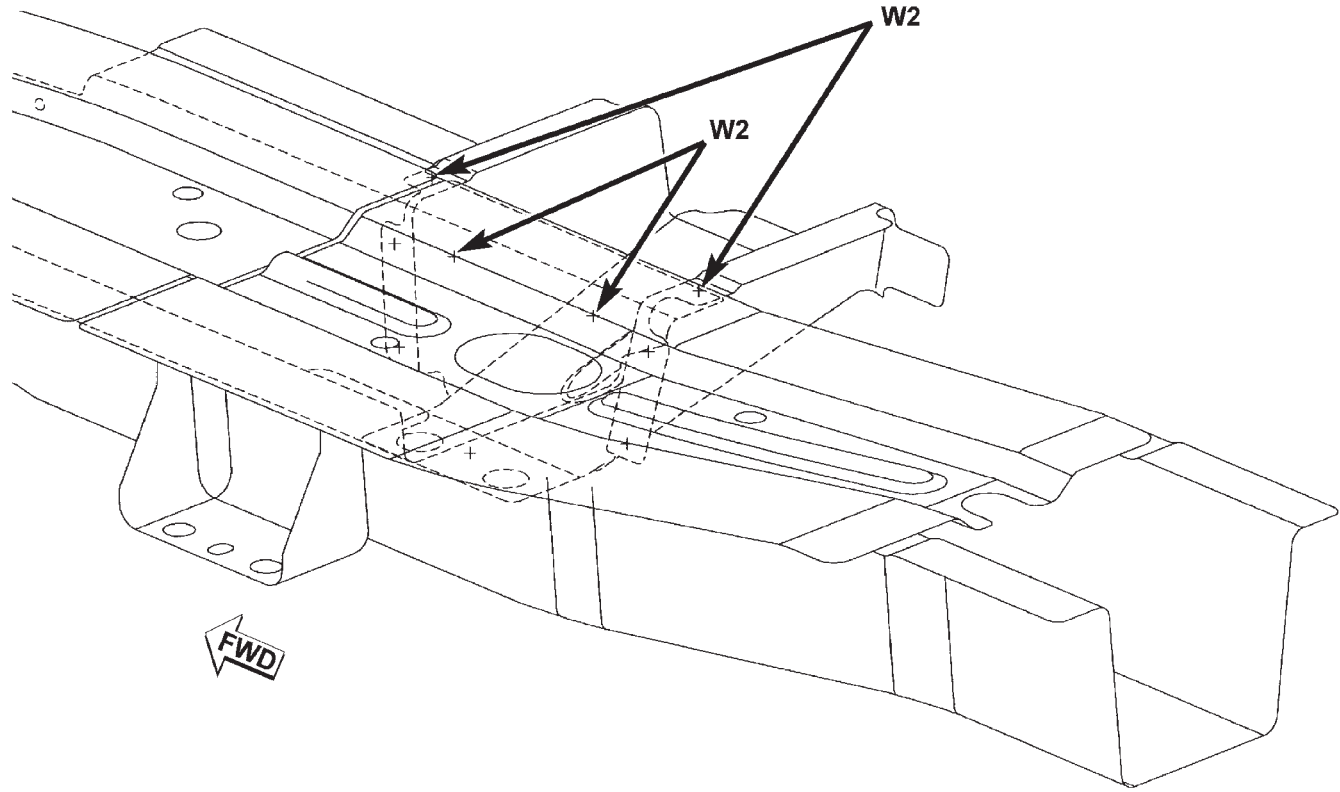
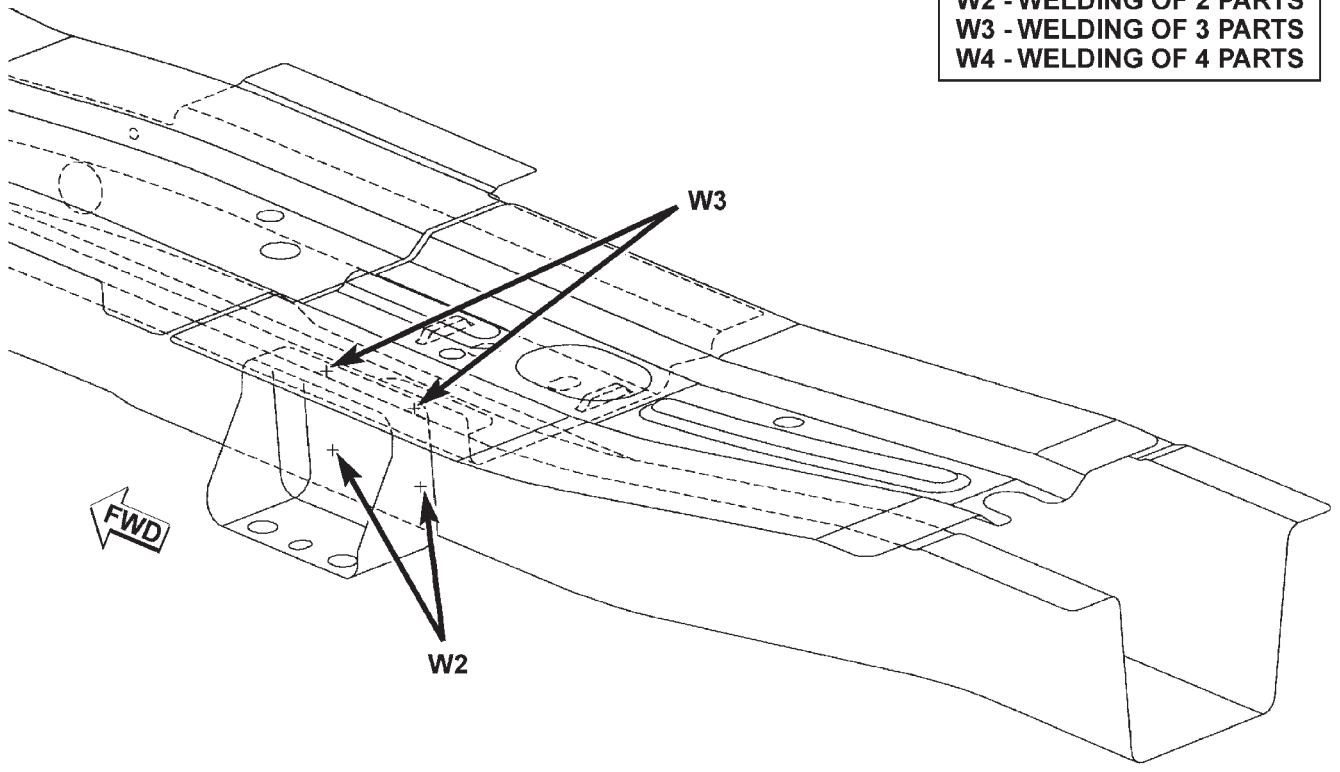

SPECIFICATIONS (Continued)

UPPER SILLS AND UPPER CONTROL ARM REINFORCEMENT AND BRACKETS TO FRONT SILLS

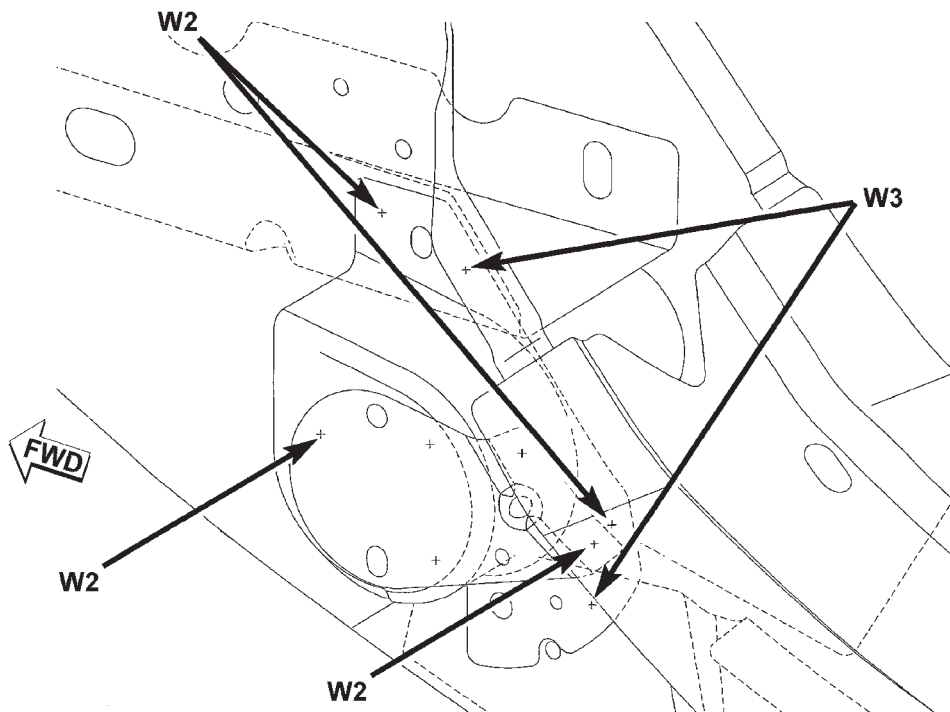
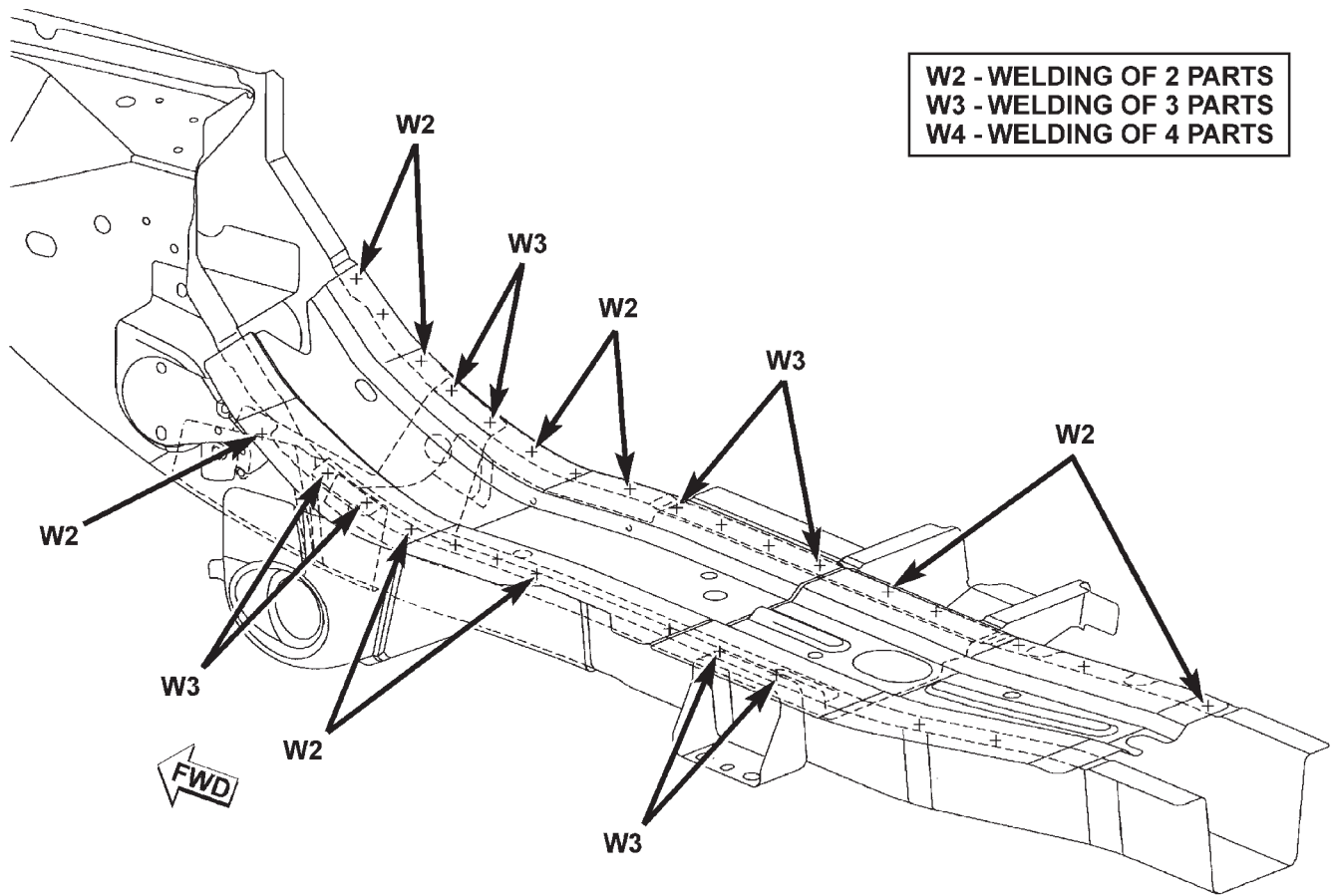

SPECIFICATIONS (Continued)

REINFORCEMENT TO FRONT OUTER SILLS

W2 - WELDING OF 2 PARTS
W3 - WELDING OF 3 PARTS
W4 - WELDING OF 4 PARTS

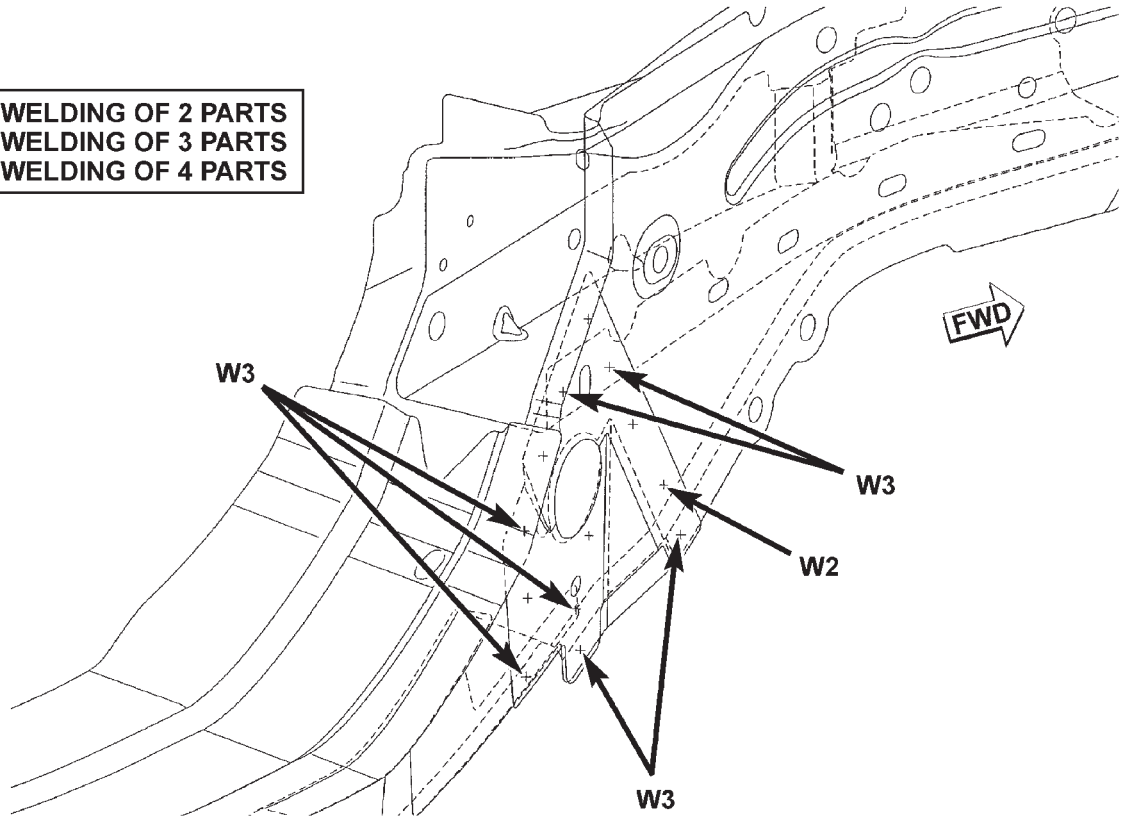

SPECIFICATIONS (Continued)

FRONT INNER SILL TO FRONT OUTER SILL

W2 - WELDING OF 2 PARTS
W3 - WELDING OF 3 PARTS
W4 - WELDING OF 4 PARTS

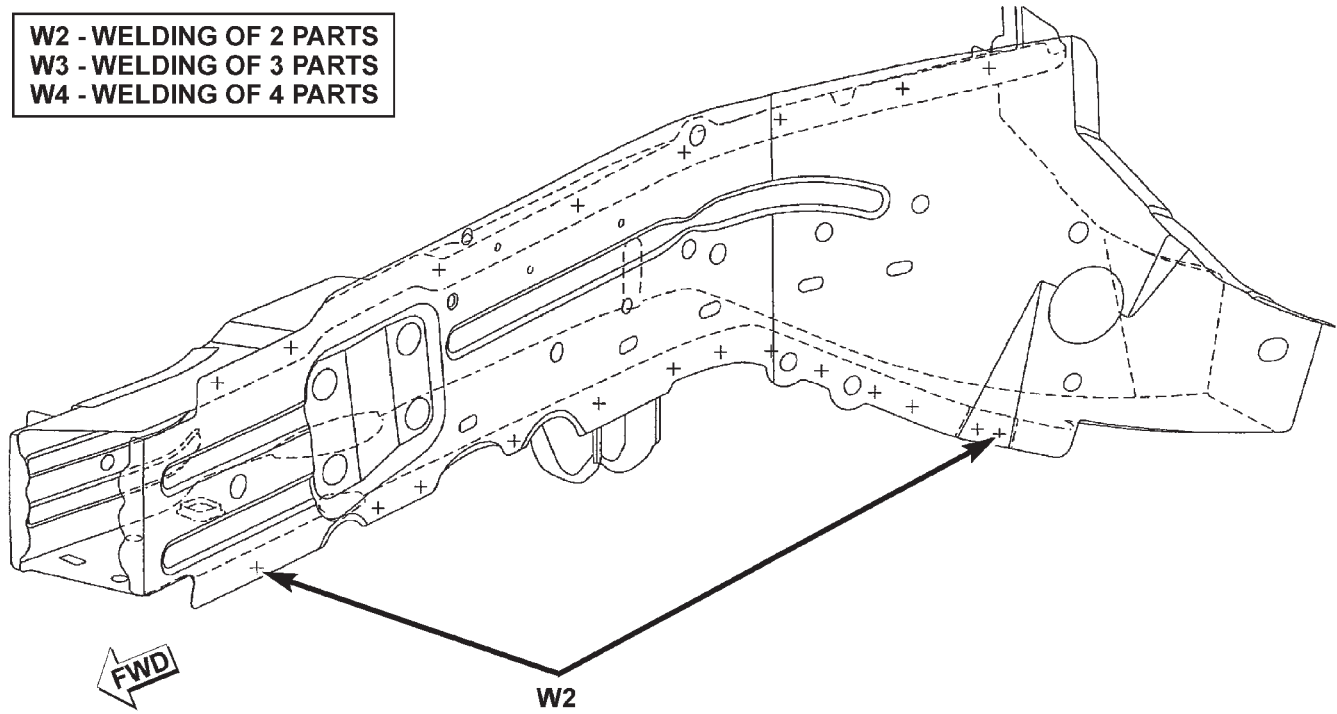

SPECIFICATIONS (Continued)

OUTER TRACK BAR BRACKET TO FRONT OUTER SILL

W2 - WELDING OF 2 PARTS
W3 - WELDING OF 3 PARTS
W4 - WELDING OF 4 PARTS

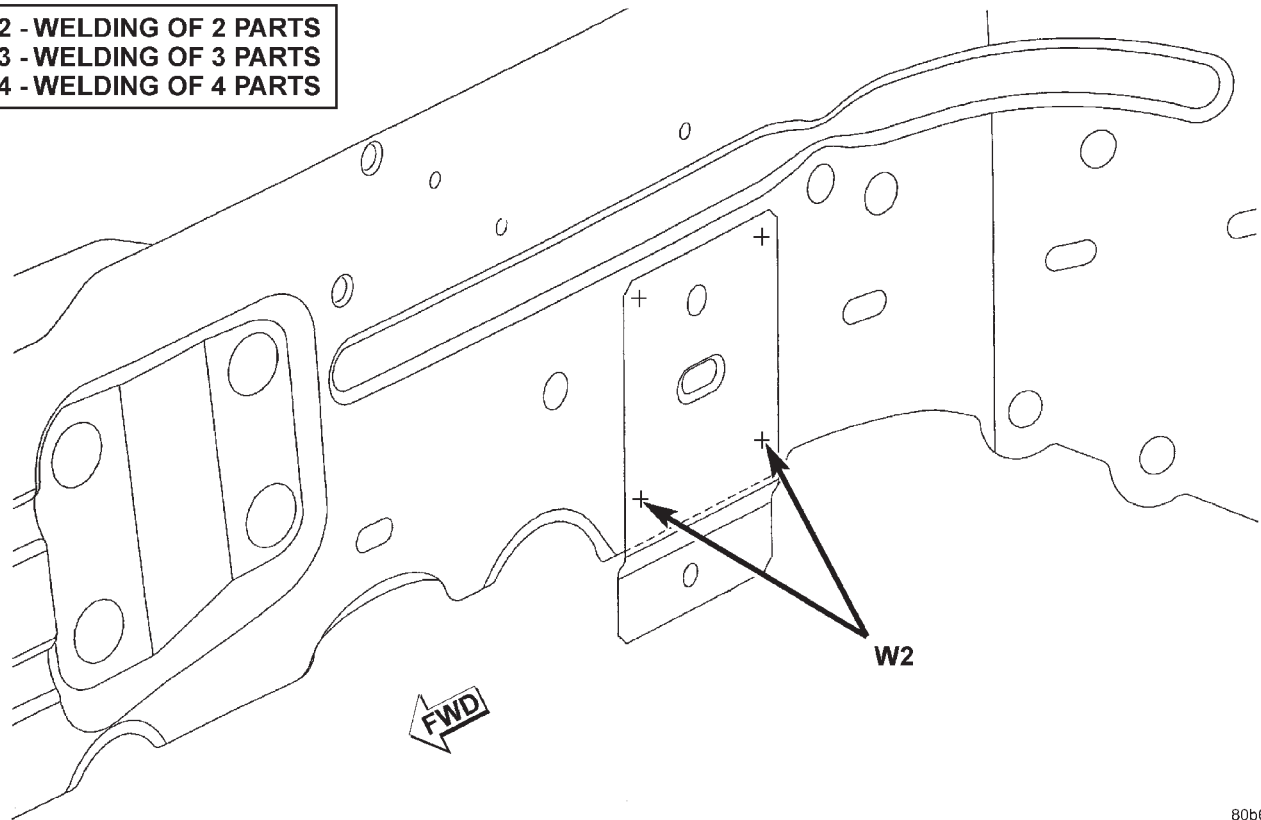

SPECIFICATIONS (Continued)

REINFORCEMENT FOR FRONT ENGINE MOUNTING AND STEERING GEAR TO FRONT INNER SILL

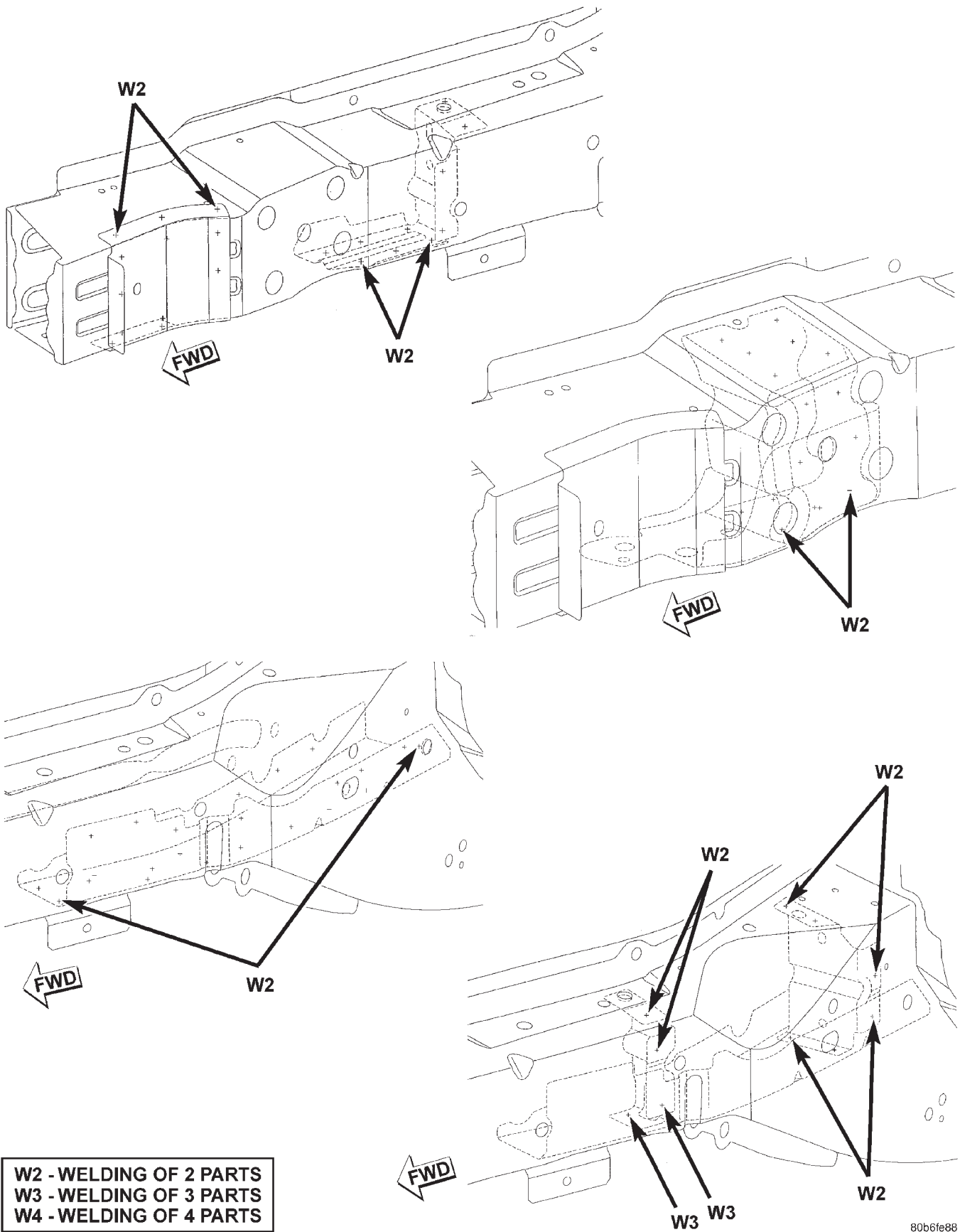

SPECIFICATIONS (Continued)

LARGE AND SMALL SWAY BAR TAPPING PLATES
TO FRONT INNER SILLS

W2 - WELDING OF 2 PARTS
W3 - WELDING OF 3 PARTS
W4 - WELDING OF 4 PARTS

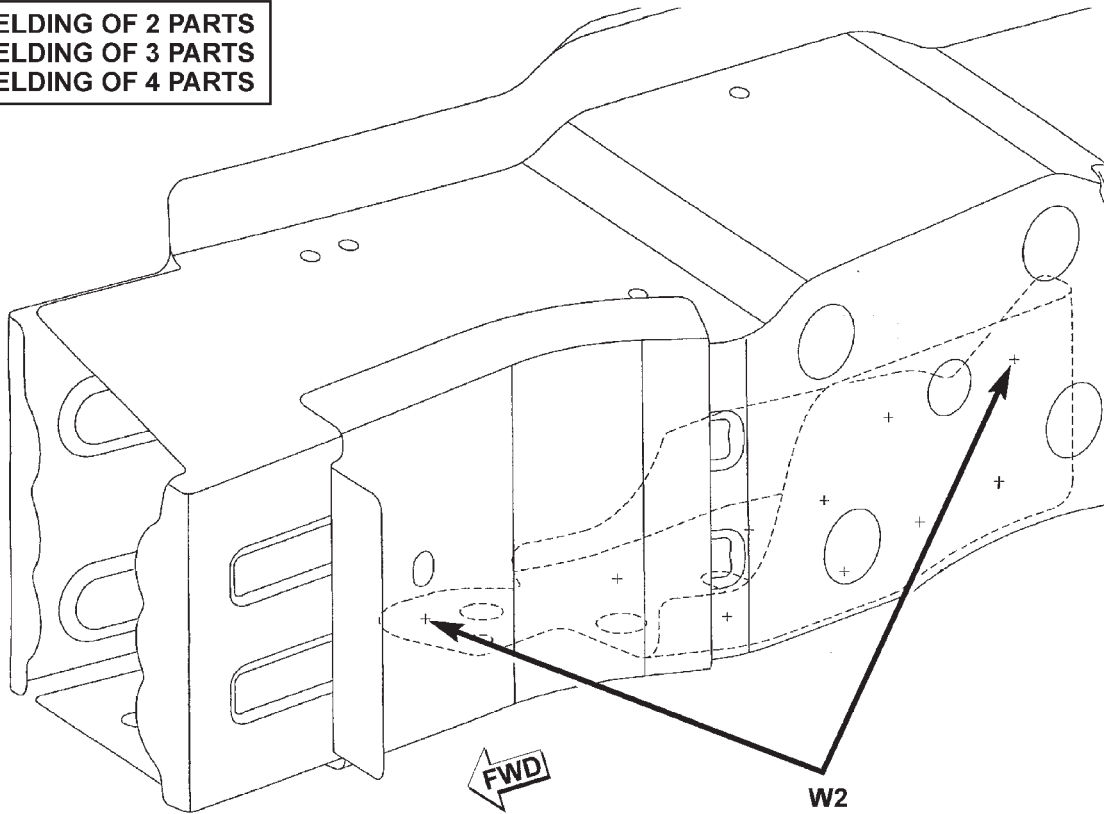

SPECIFICATIONS (Continued)

FRONT AND REAR DOOR HINGE TAPPING PLATES

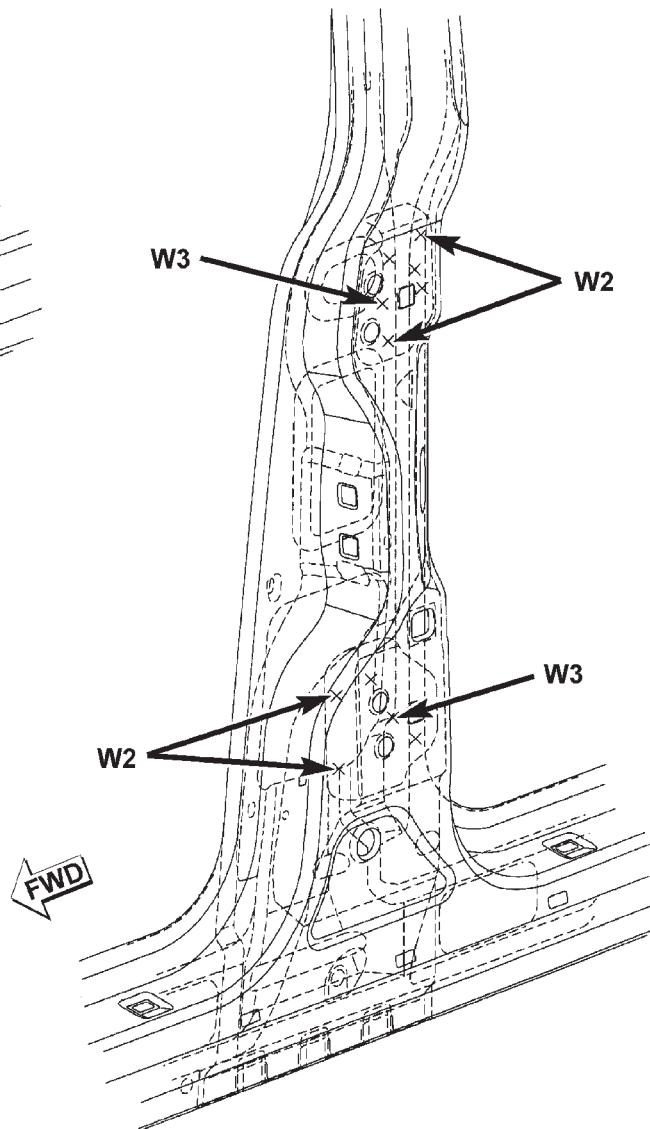
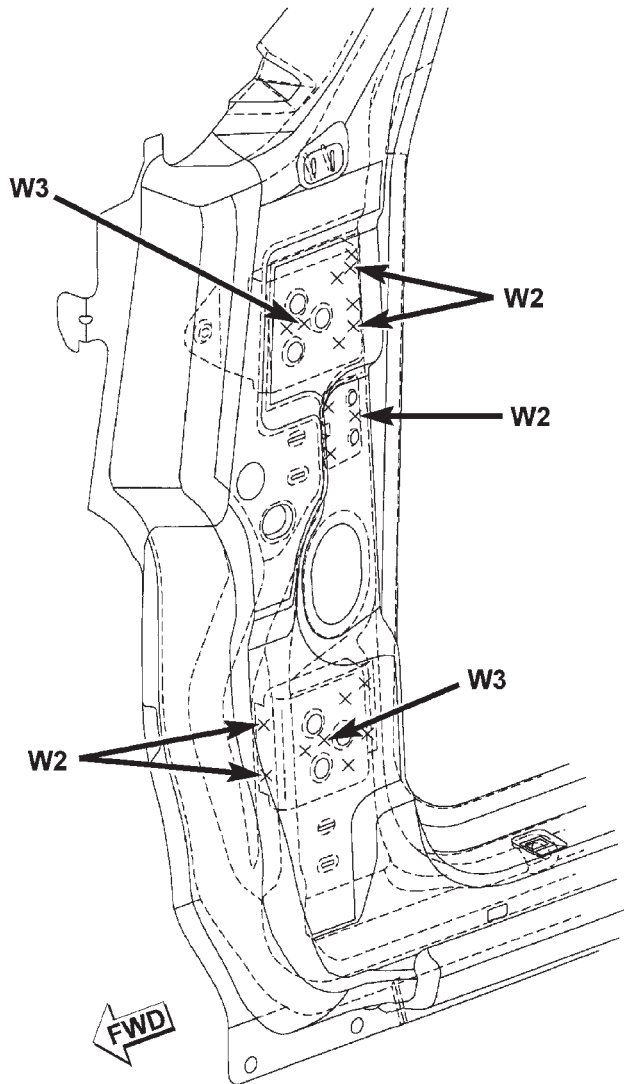

W2 - WELDING OF 2 PARTS
W3 - WELDING OF 3 PARTS
W4 - WELDING OF 4 PARTS

SPECIFICATIONS (Continued)

REAR DOOR STRIKER REINFORCEMENT

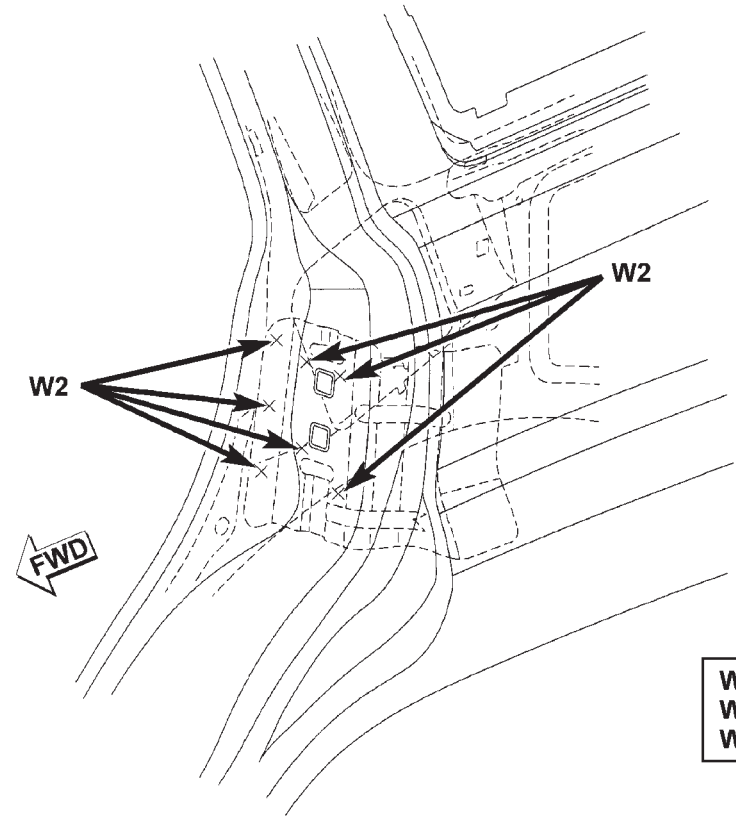

W2 - WELDING OF 2 PARTS
W3 - WELDING OF 3 PARTS
W4 - WELDING OF 4 PARTS

SPECIFICATIONS (Continued)

TAIL LAMP MOUNTING PANELS

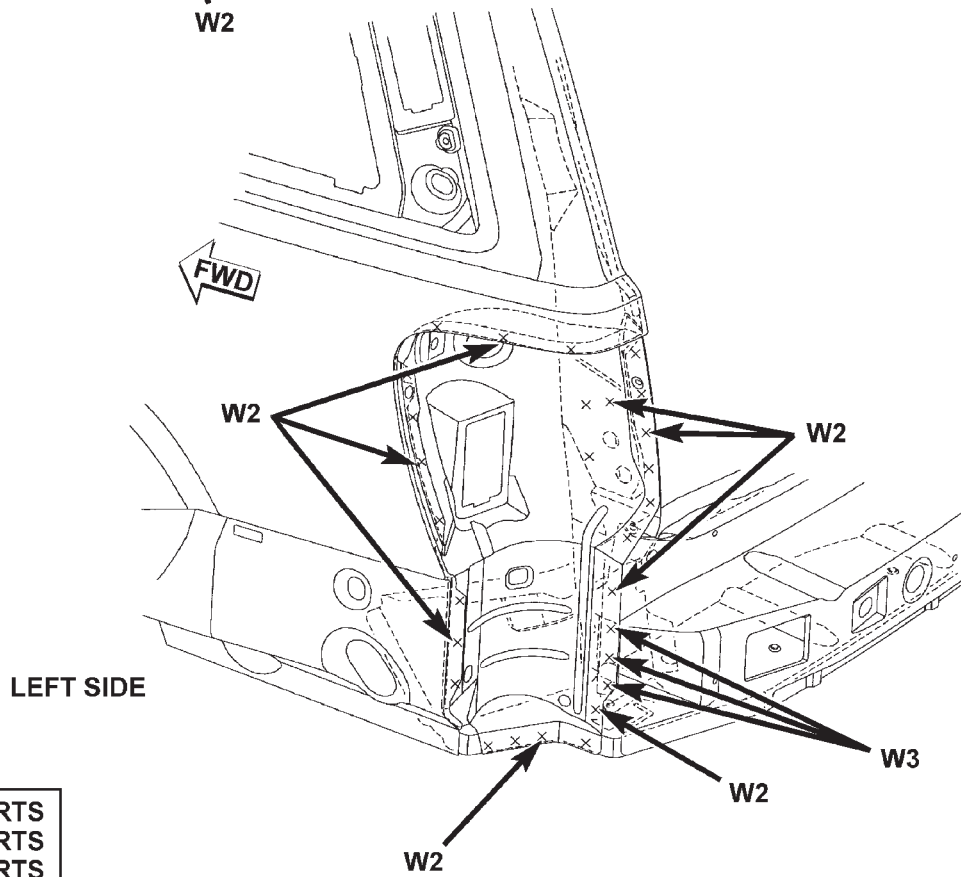
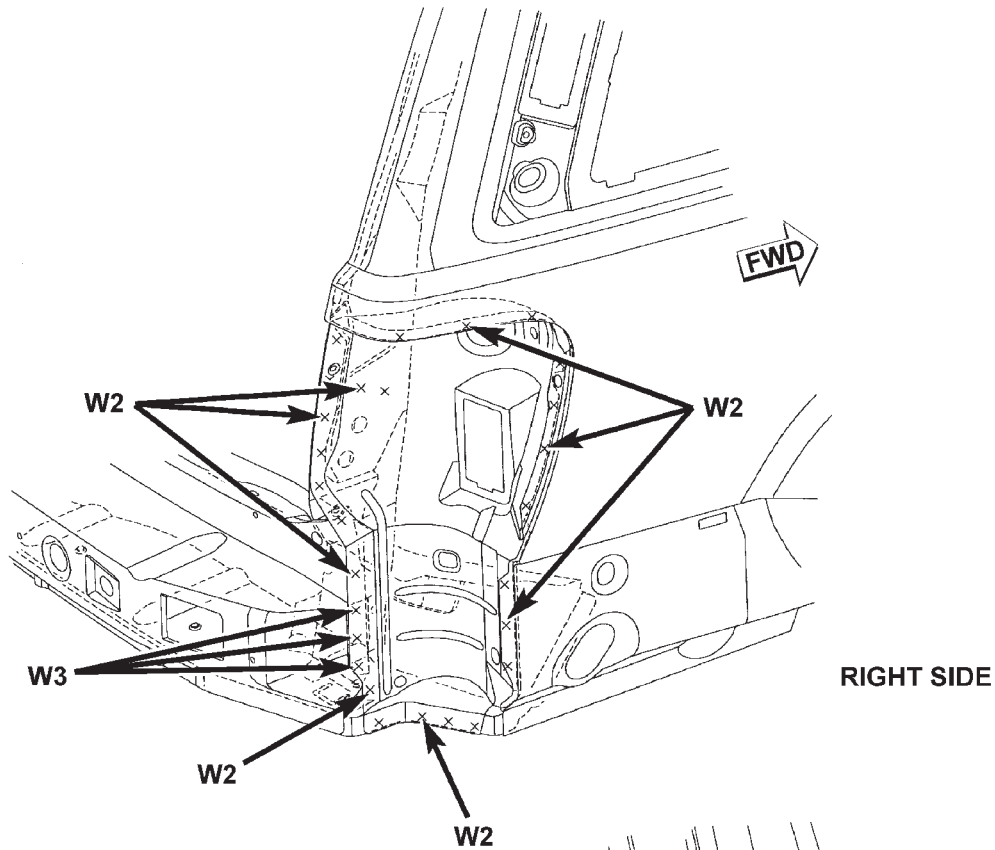

W2 - WELDING OF 2 PARTS
W3 - WELDING OF 3 PARTS
W4 - WELDING OF 4 PARTS

SPECIFICATIONS (Continued)

ROOF PANEL TO BODYSIDE APERTURE

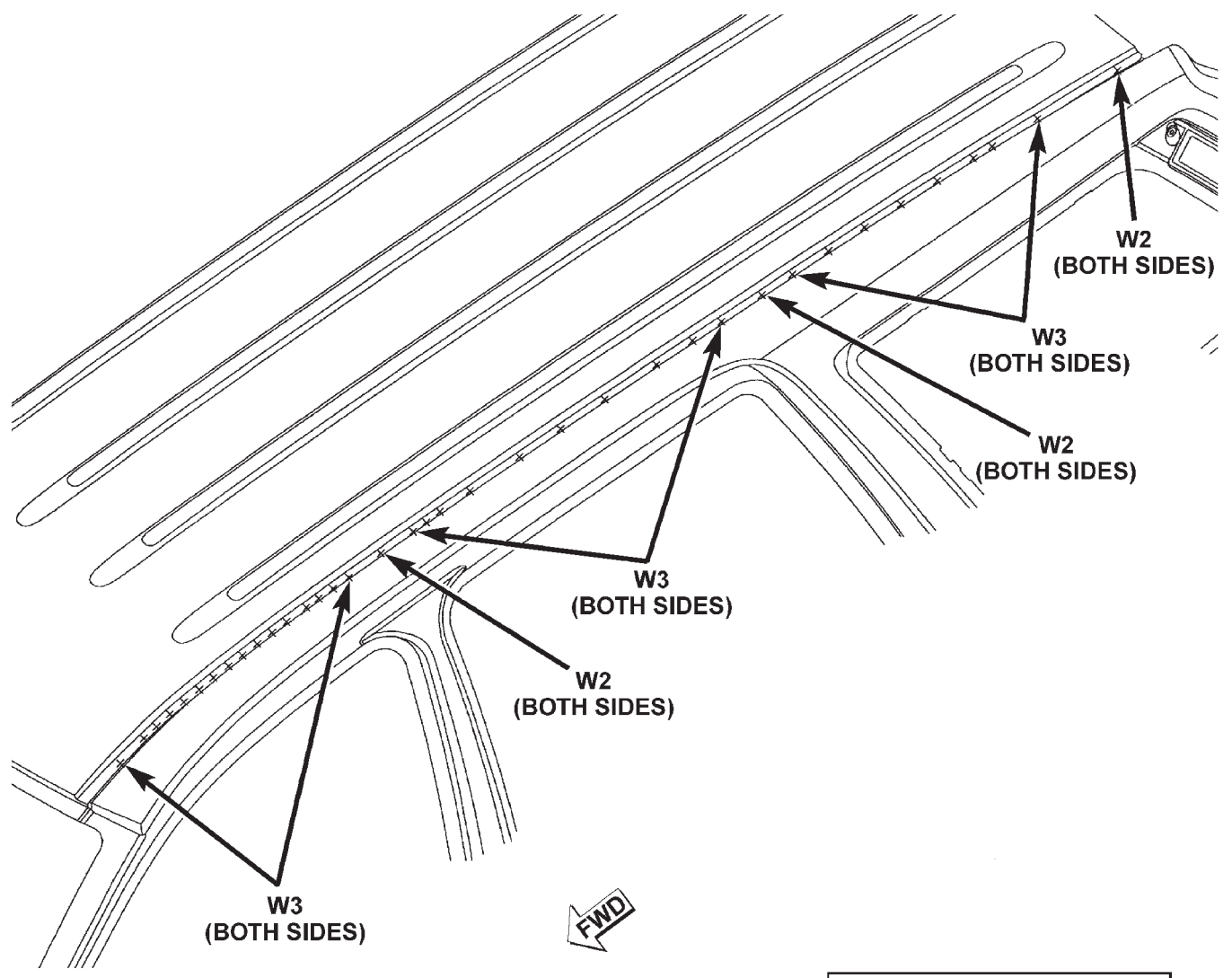

W2 - WELDING OF 2 PARTS
W3 - WELDING OF 3 PARTS
W4 - WELDING OF 4 PARTS

SPECIFICATIONS (Continued)

ROOF PANEL TO REAR HEADER

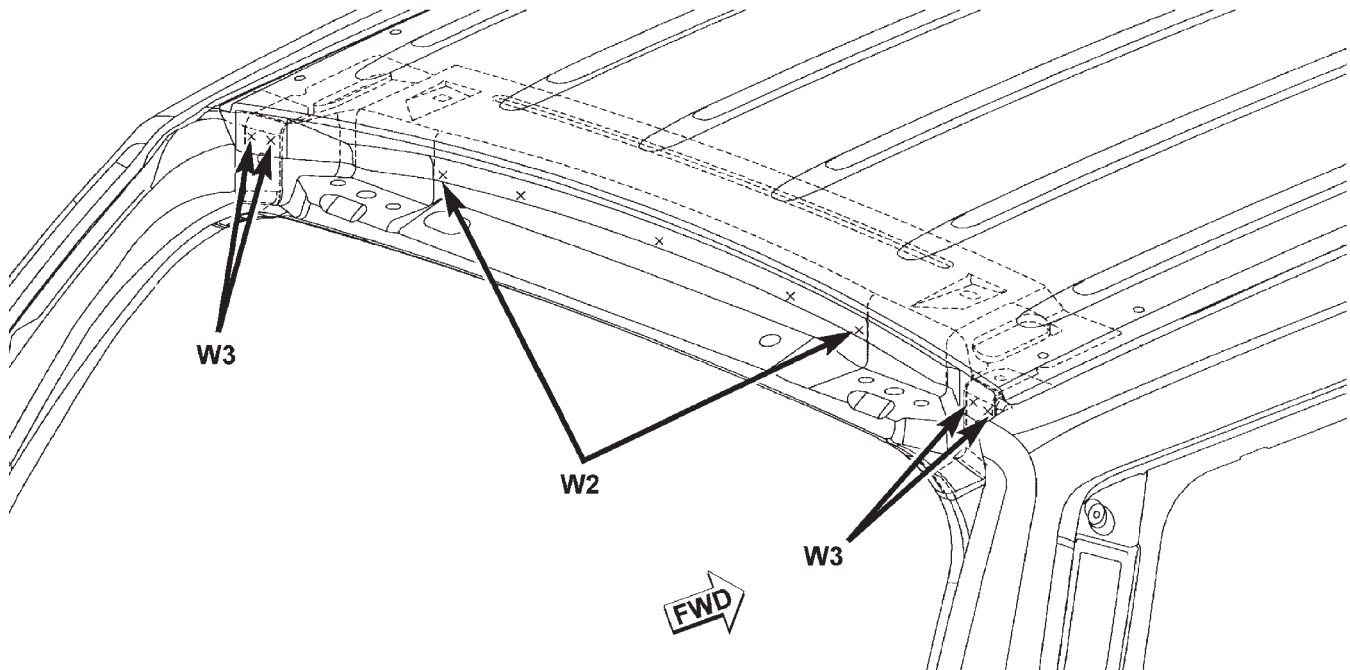

W2 - WELDING OF 2 PARTS
W3 - WELDING OF 3 PARTS
W4 - WELDING OF 4 PARTS

SPECIFICATIONS (Continued)

UPPER REAR HEADER TO LOWER HEADER

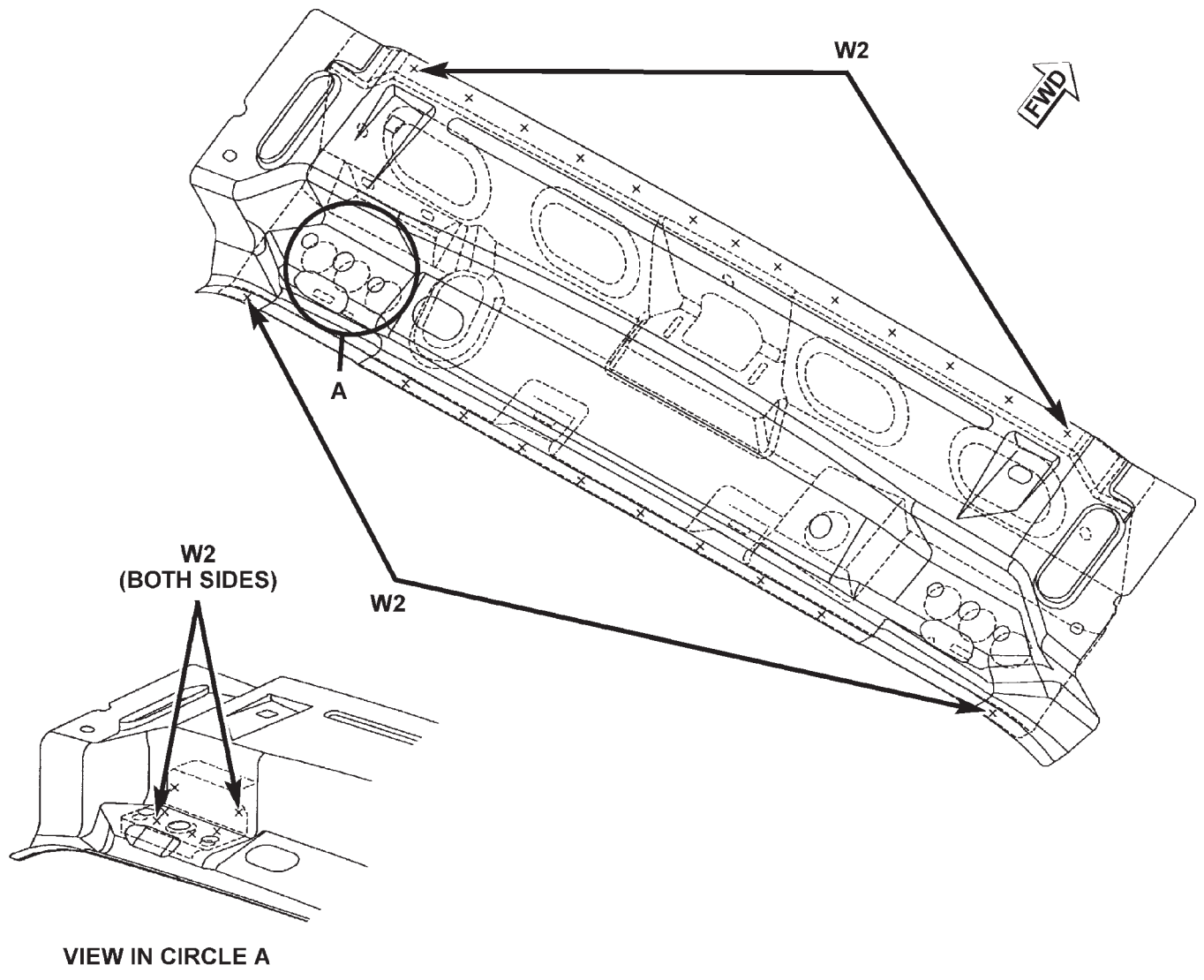

W2 - WELDING OF 2 PARTS
W3 - WELDING OF 3 PARTS
W4 - WELDING OF 4 PARTS

SPECIFICATIONS (Continued)

FRONT HEADER AND ROOF BOWS TO INNER
PANEL

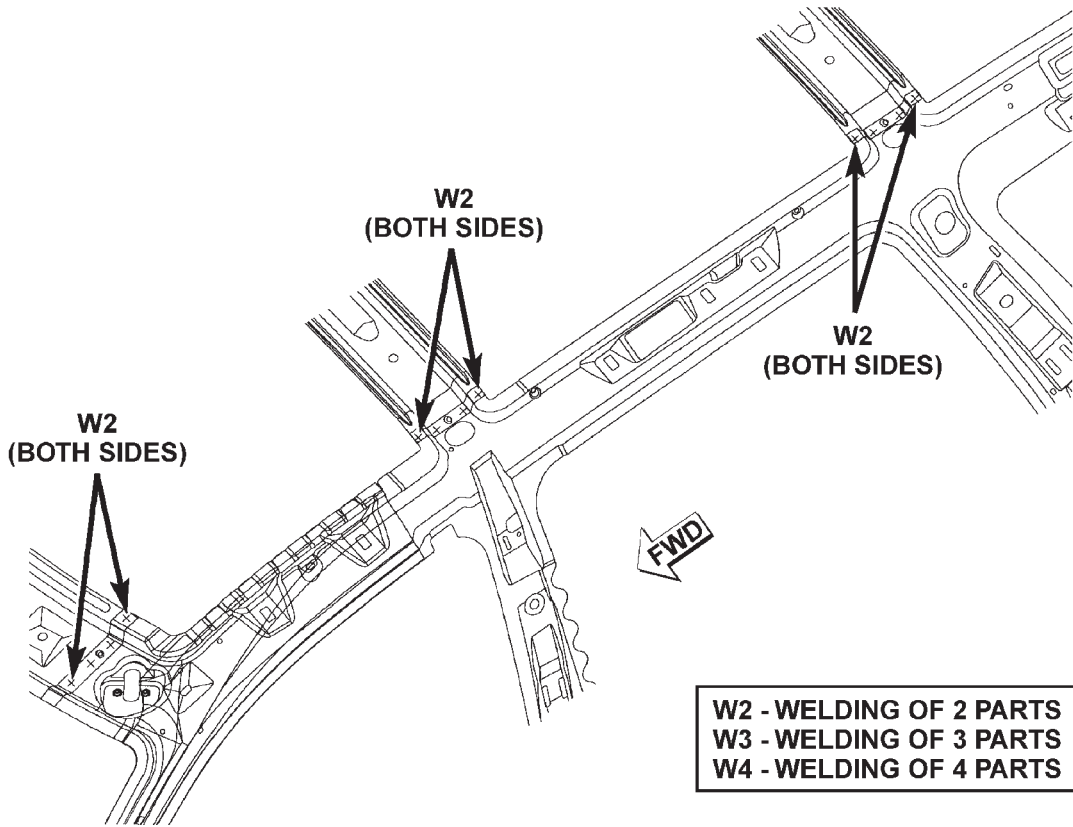

SPECIFICATIONS (Continued)

FRONT SEAT/SHOULDER BELT TO INNER PANEL REINFORCEMENT

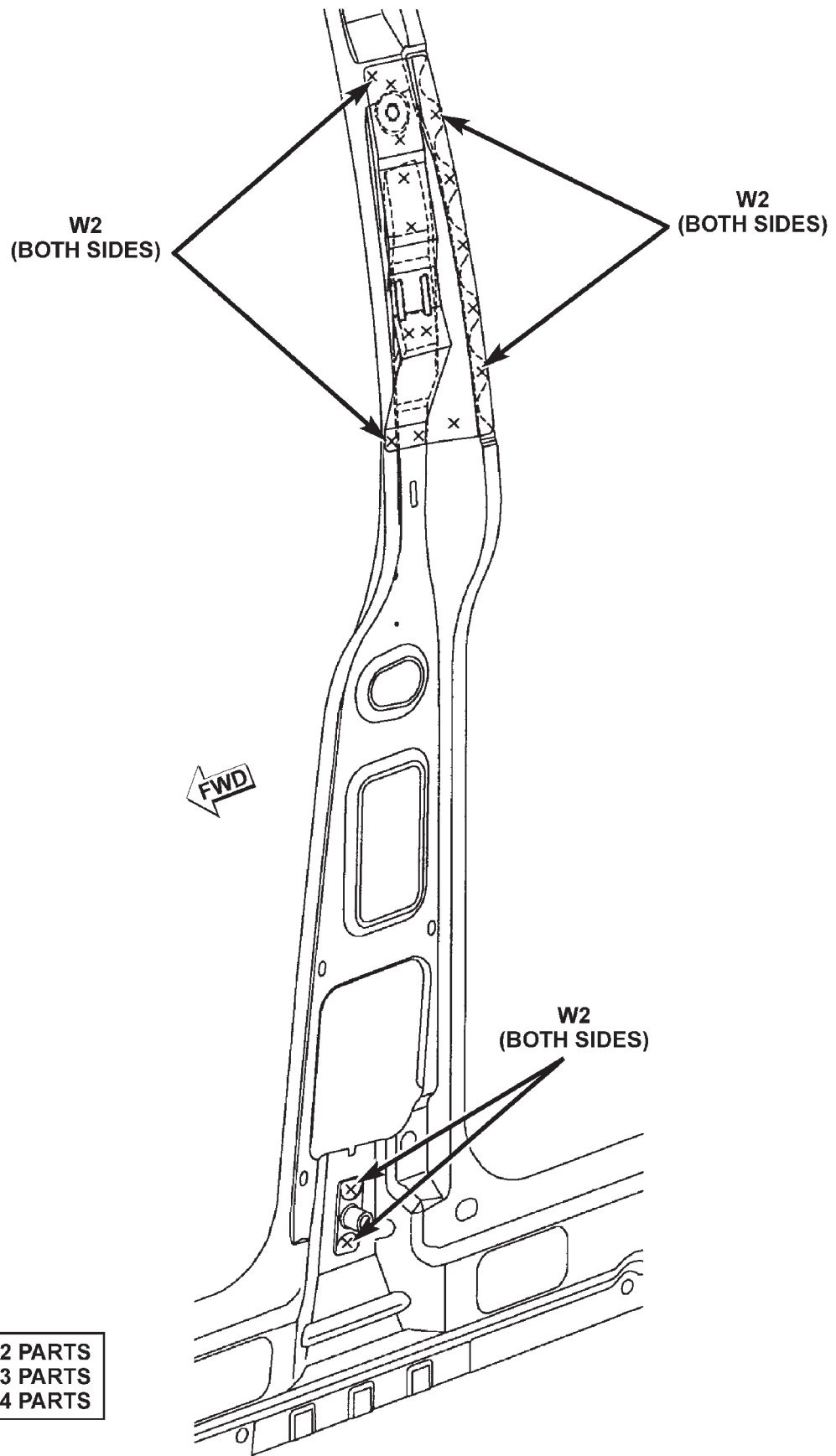

SPECIFICATIONS (Continued)

REAR SEAT/SHOULDER BELT TO INNER PANEL REINFORCEMENT

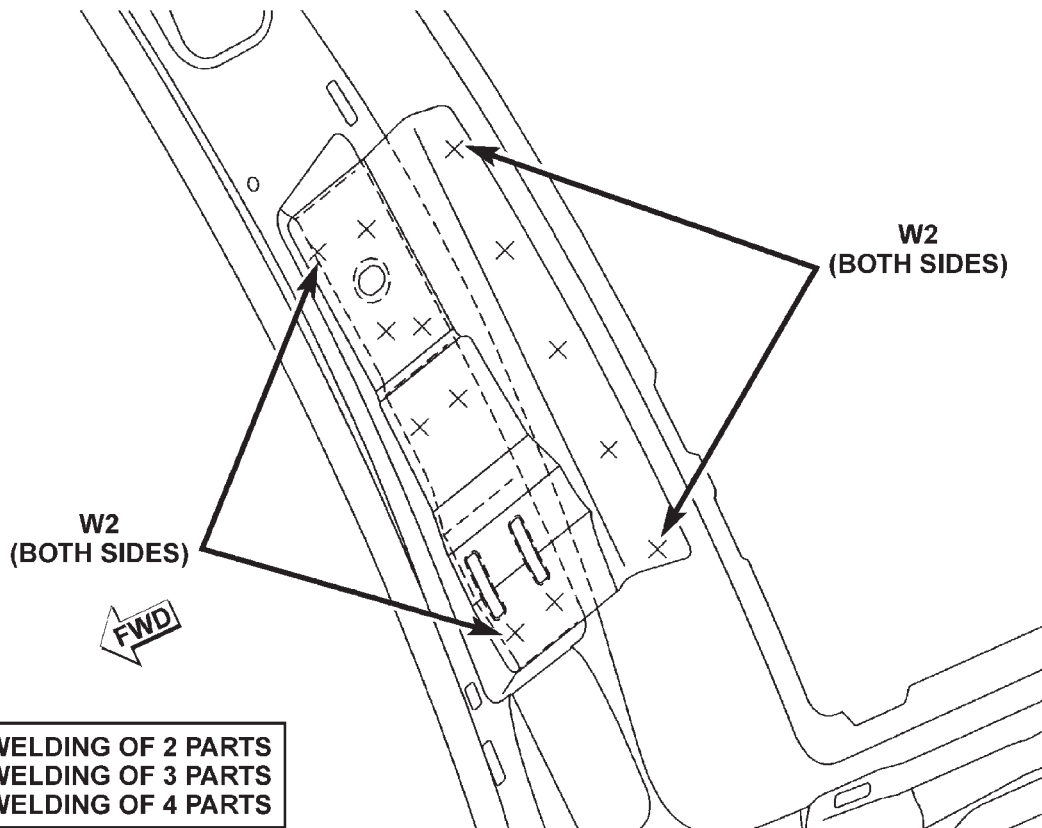

80b6te4e

SPECIFICATIONS (Continued)

FUEL FILLER GUSSET TO INNER QUARTER PANEL

W2 - WELDING OF 2 PARTS
W3 - WELDING OF 3 PARTS
W4 - WELDING OF 4 PARTS

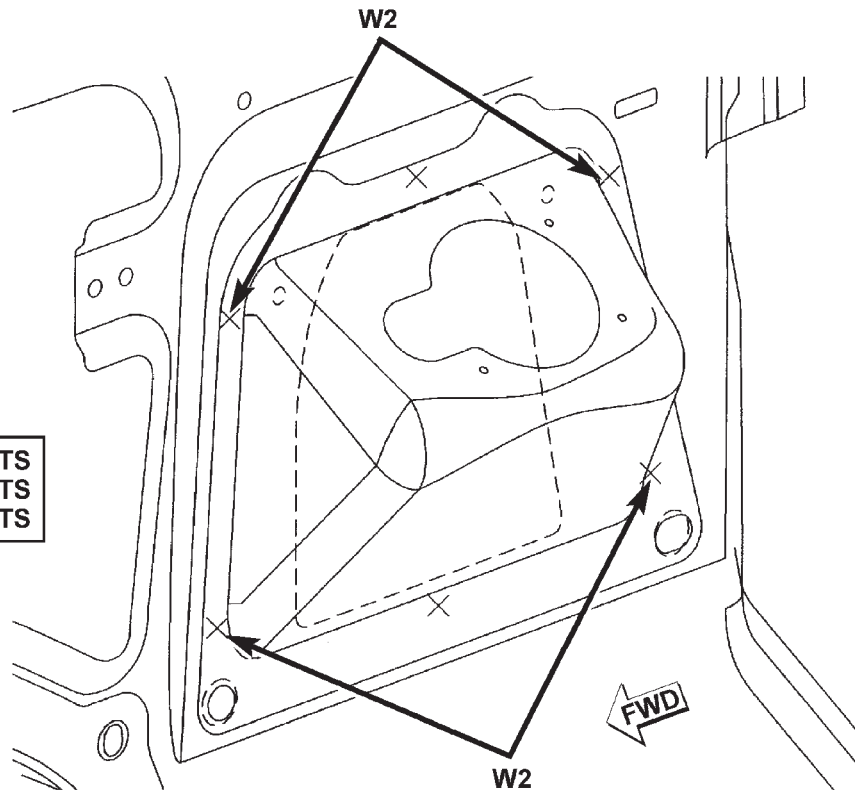

SPECIFICATIONS (Continued)

FRONT FLOOR PAN TO SILL REINFORCEMENT

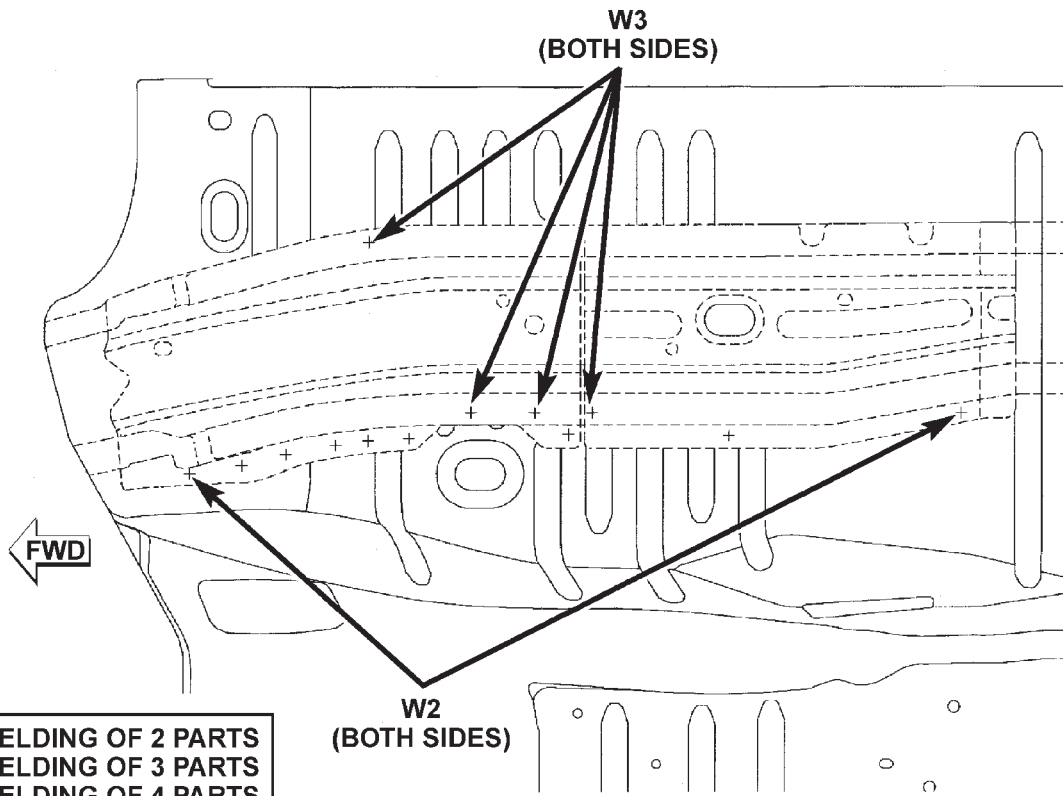

80b6fe2d

SPECIFICATIONS (Continued)

CENTER FLOOR PAN TO REAR SEAT CROSSMEMBER

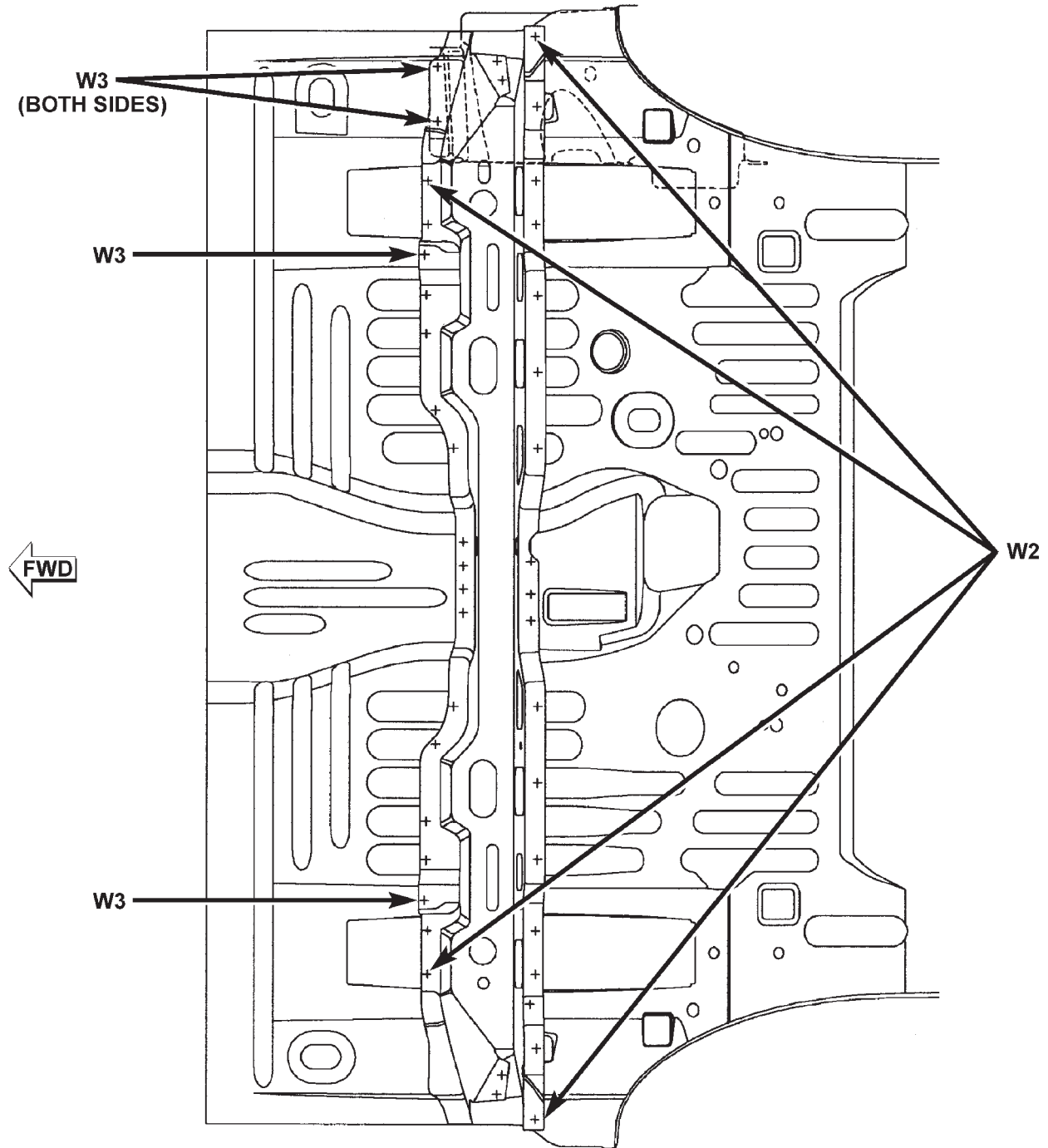

W2 - WELDING OF 2 PARTS
W3 - WELDING OF 3 PARTS
W4 - WELDING OF 4 PARTS

SPECIFICATIONS (Continued)

FRONT FLOOR PAN TO FRONT SEAT REINFORCEMENT AND RAILS

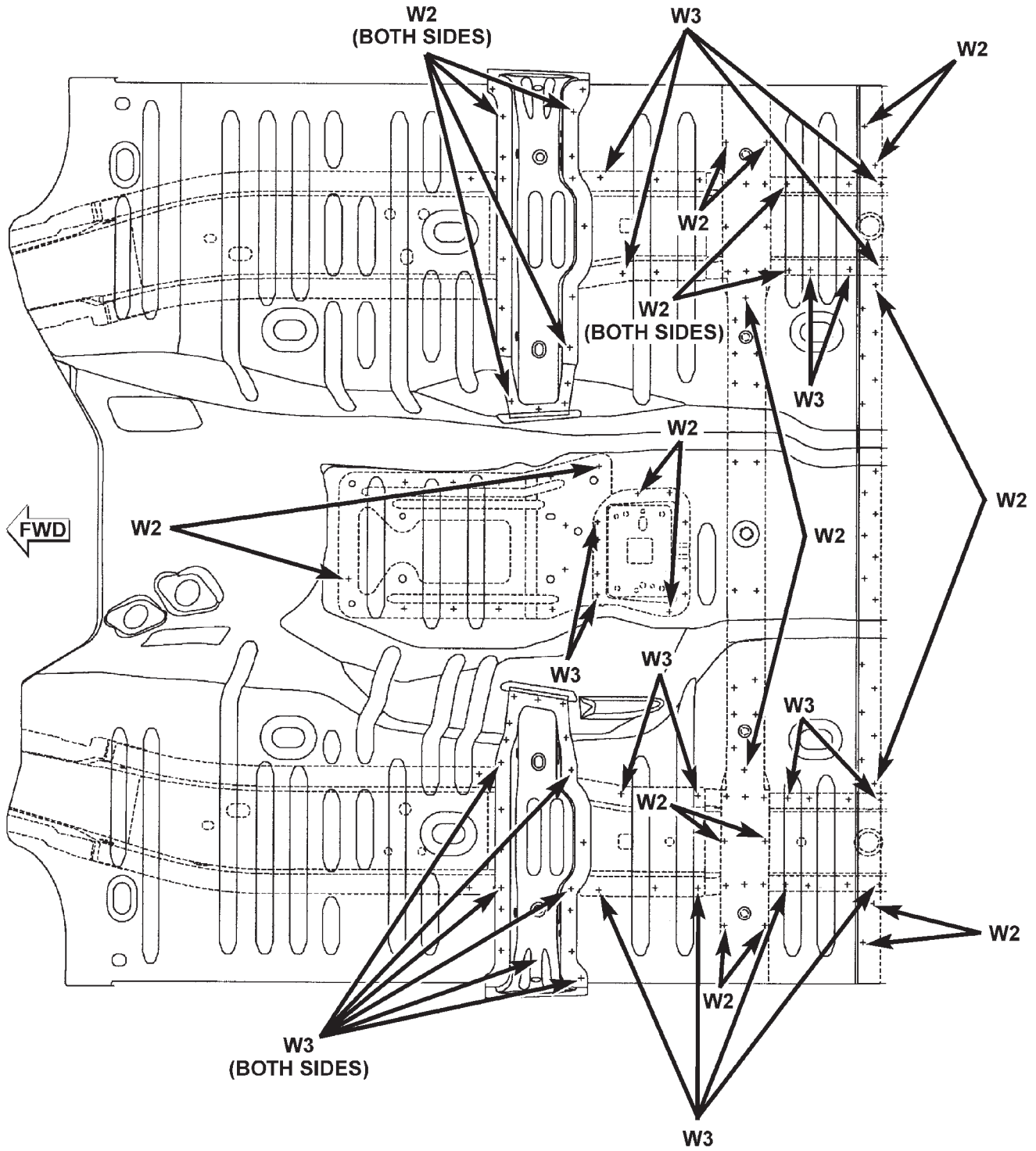

W2 - WELDING OF 2 PARTS
W3 - WELDING OF 3 PARTS
W4 - WELDING OF 4 PARTS

SPECIFICATIONS (Continued)

CENTER FLOOR PAN TO UPPER CONTROL ARM CROSSMEMBER AND RAILS

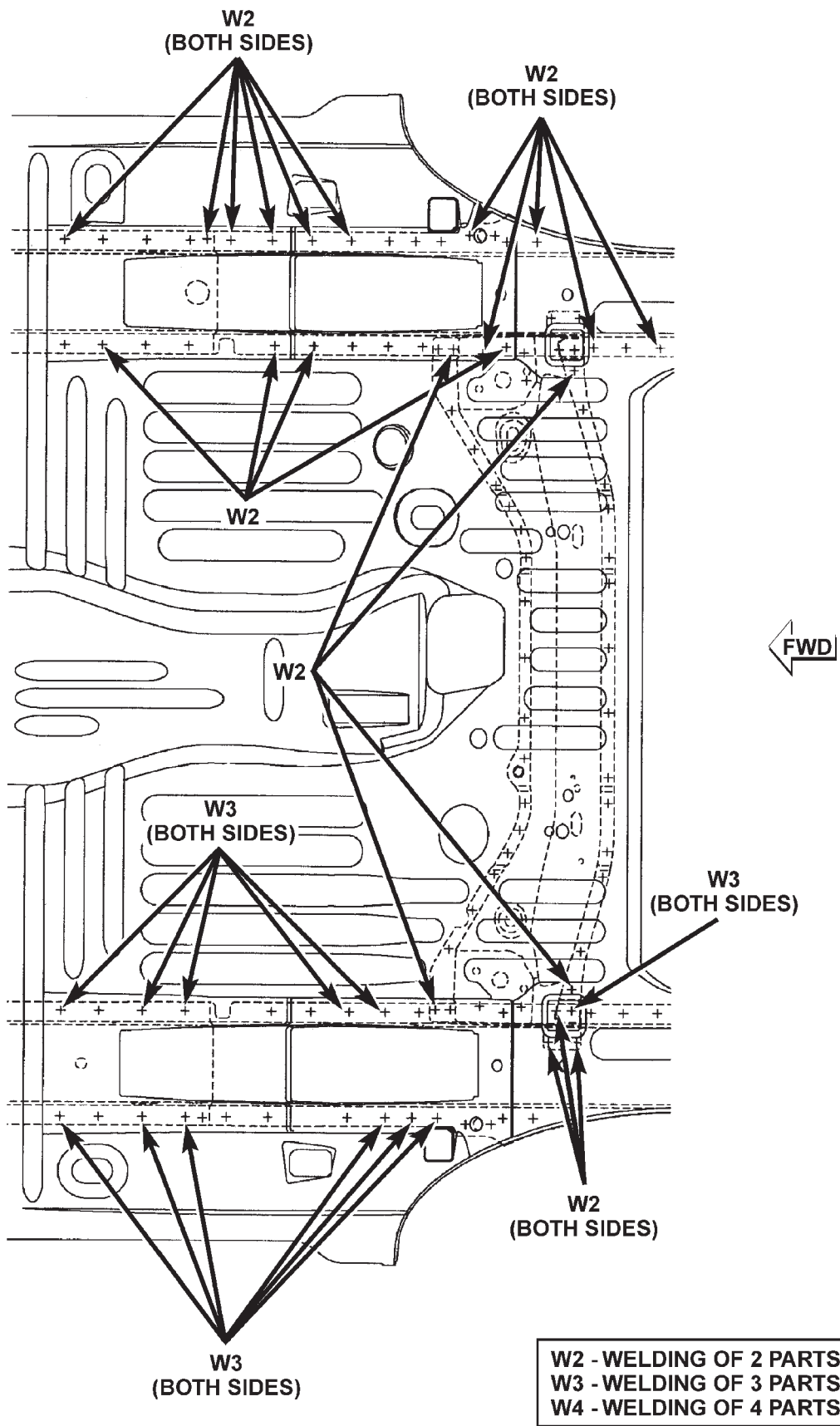

SPECIFICATIONS (Continued)

REAR FLOOR PAN TO RAILS AND SPRING GUIDE CROSSMEMBER

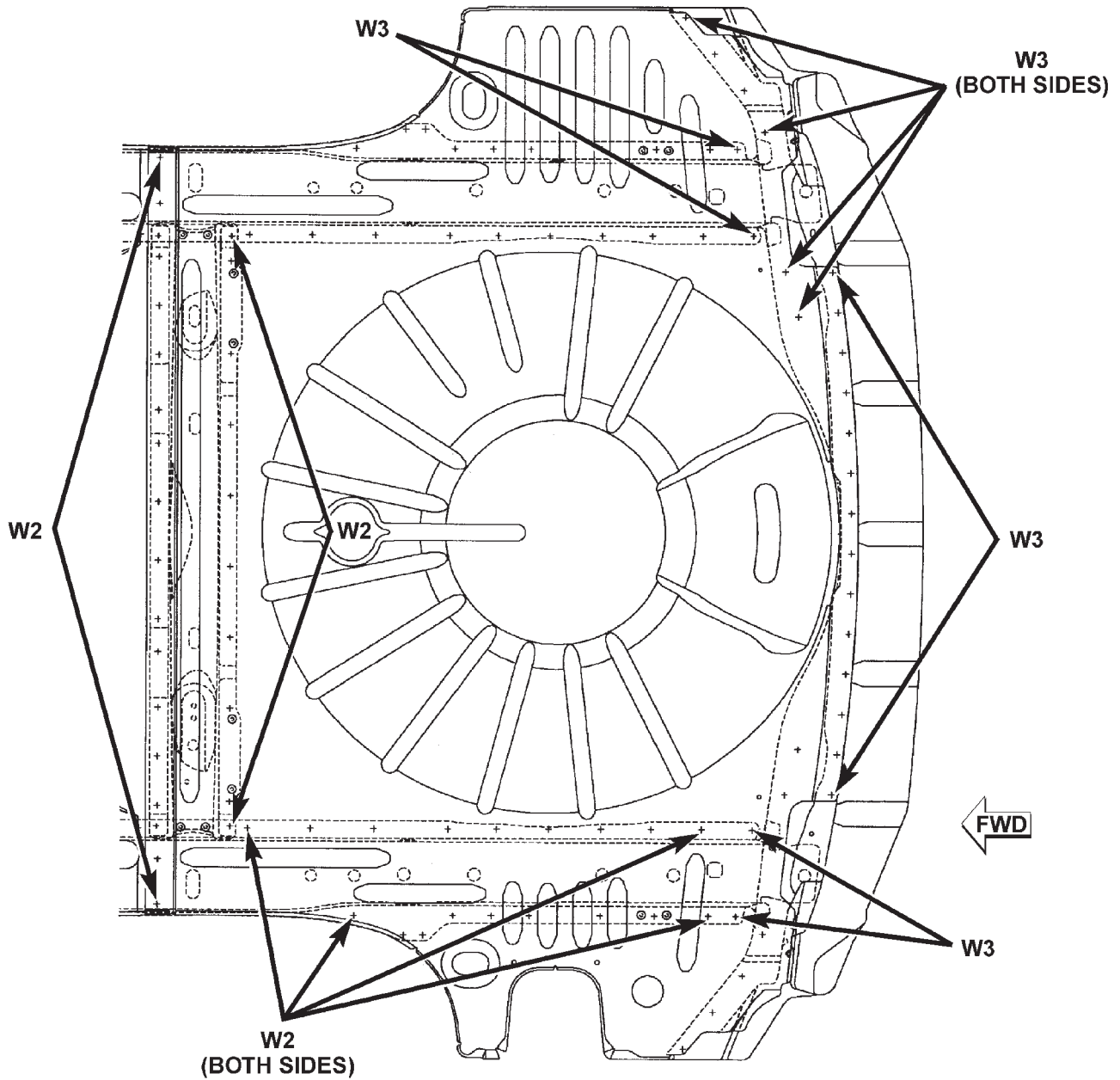

W2 - WELDING OF 2 PARTS
W3 - WELDING OF 3 PARTS
W4 - WELDING OF 4 PARTS

SPECIFICATIONS (Continued)

REAR RAILS

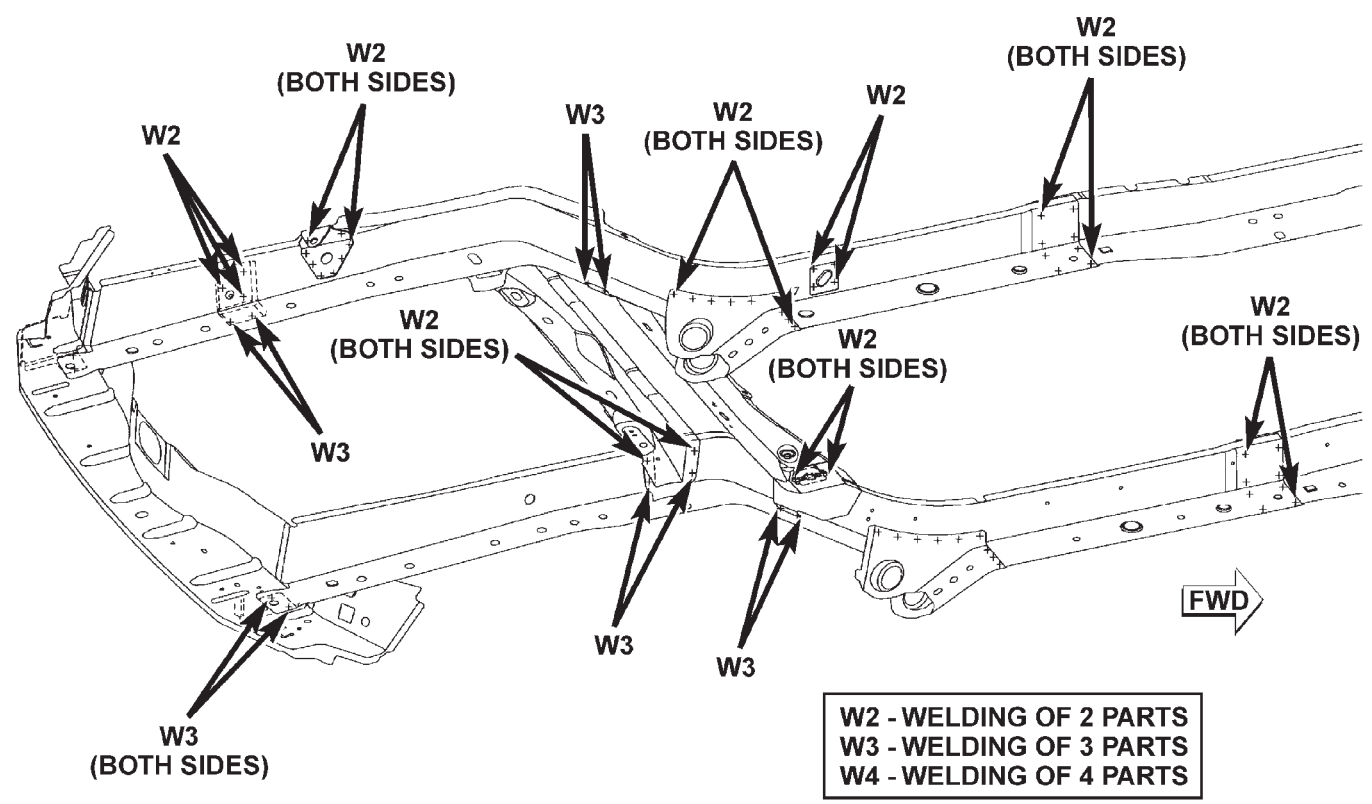

8066e32

SPECIFICATIONS (Continued)

UPPER CONTROL ARM CROSSMEMBER TO REAR RAIL

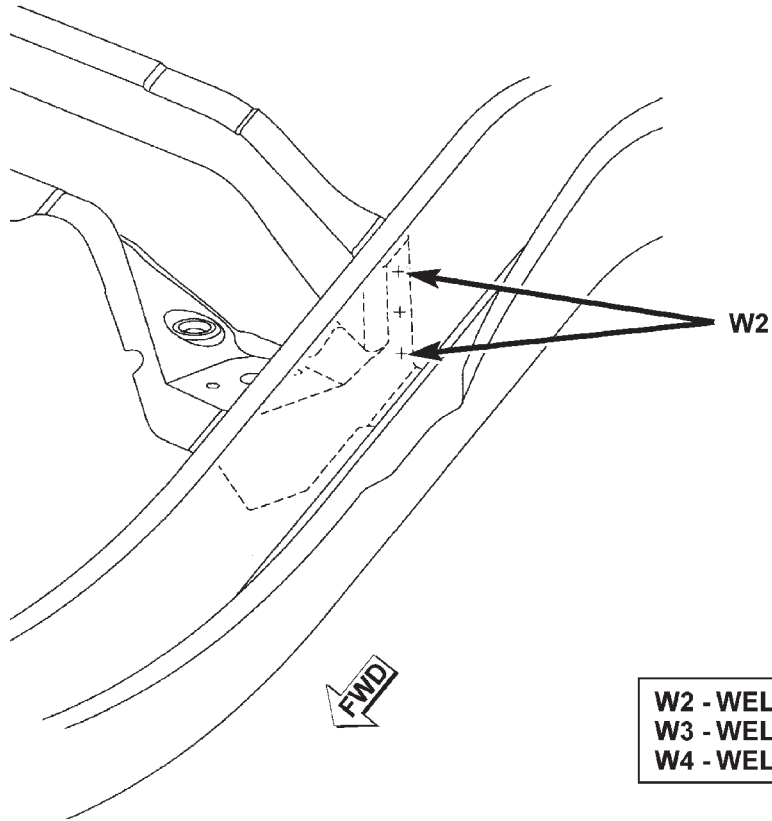

SPECIFICATIONS (Continued)

REAR RAIL REINFORCEMENT TO REAR RAILS

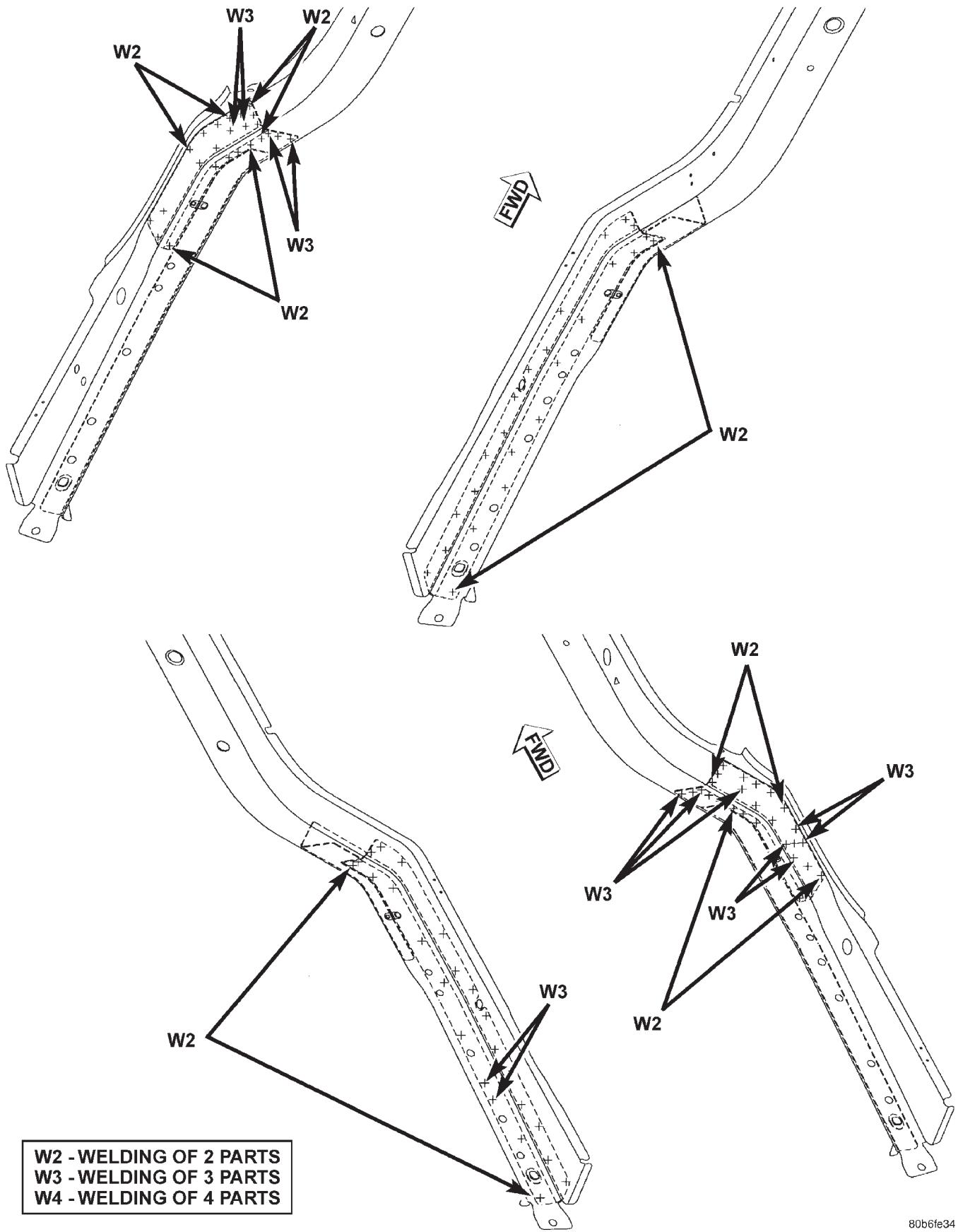

SPECIFICATIONS (Continued)

UPPER CONTROL ARM REINFORCEMENTS TO REAR RAIL

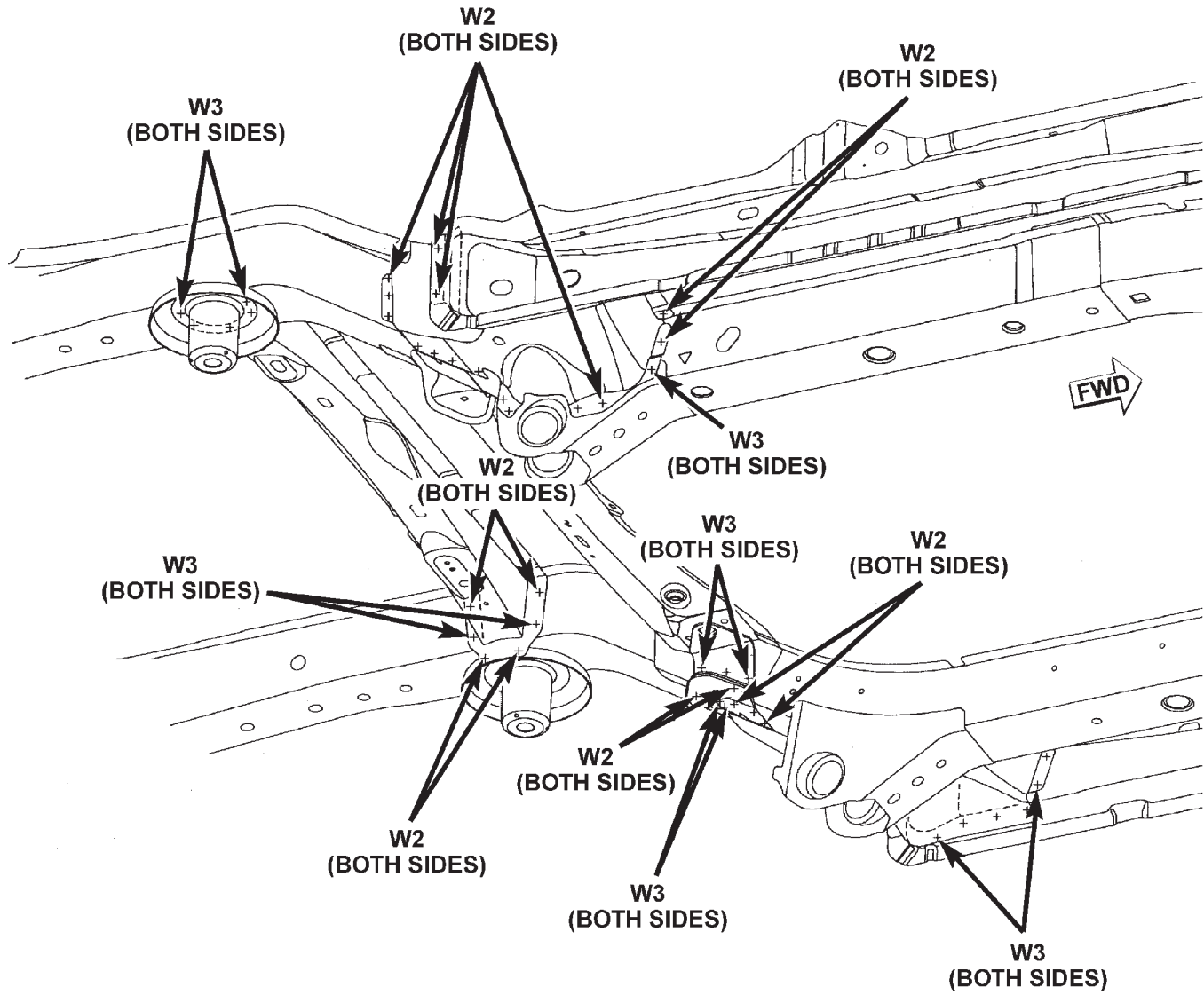

W2 - WELDING OF 2 PARTS
W3 - WELDING OF 3 PARTS
W4 - WELDING OF 4 PARTS

SPECIFICATIONS (Continued)

OUTER TRANSMISSION CROSSMEMBER REINFORCEMENT TO RAIL AND BODYSIDE SILL

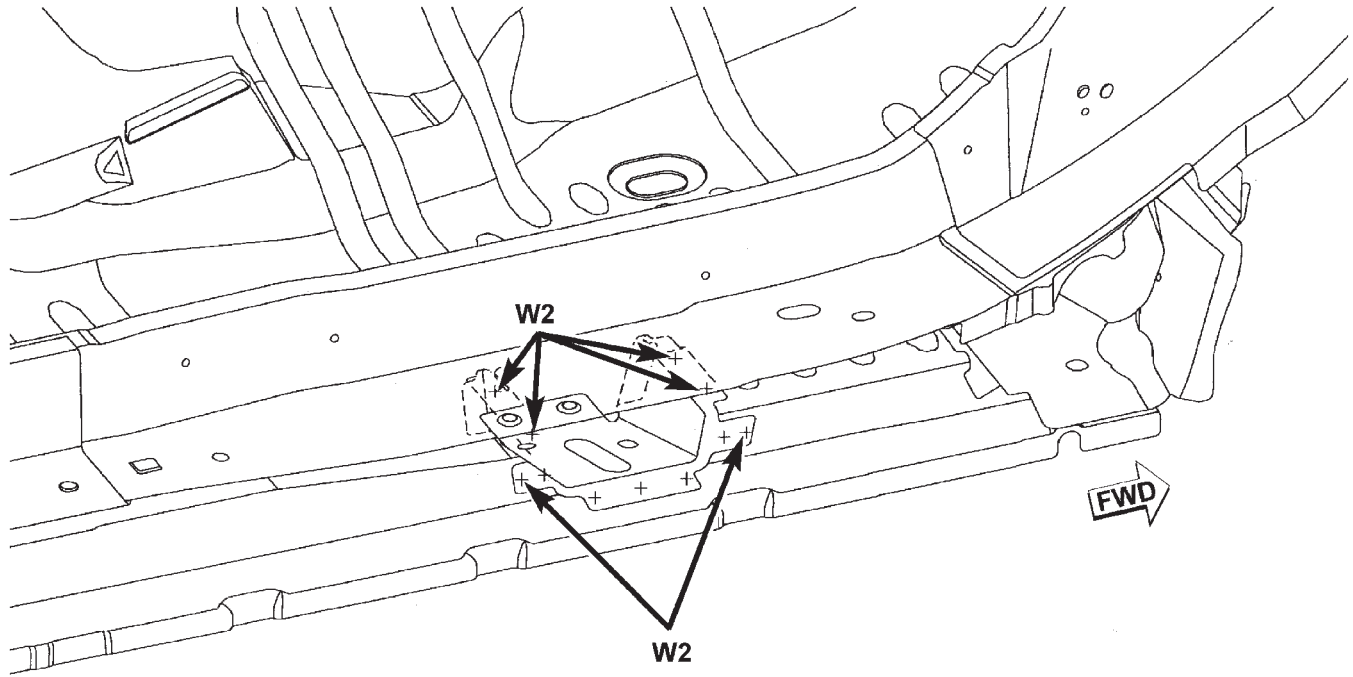

W2 - WELDING OF 2 PARTS
W3 - WELDING OF 3 PARTS
W4 - WELDING OF 4 PARTS

SPECIFICATIONS (Continued)

BODYSIDE SILL TO FLOOR PAN

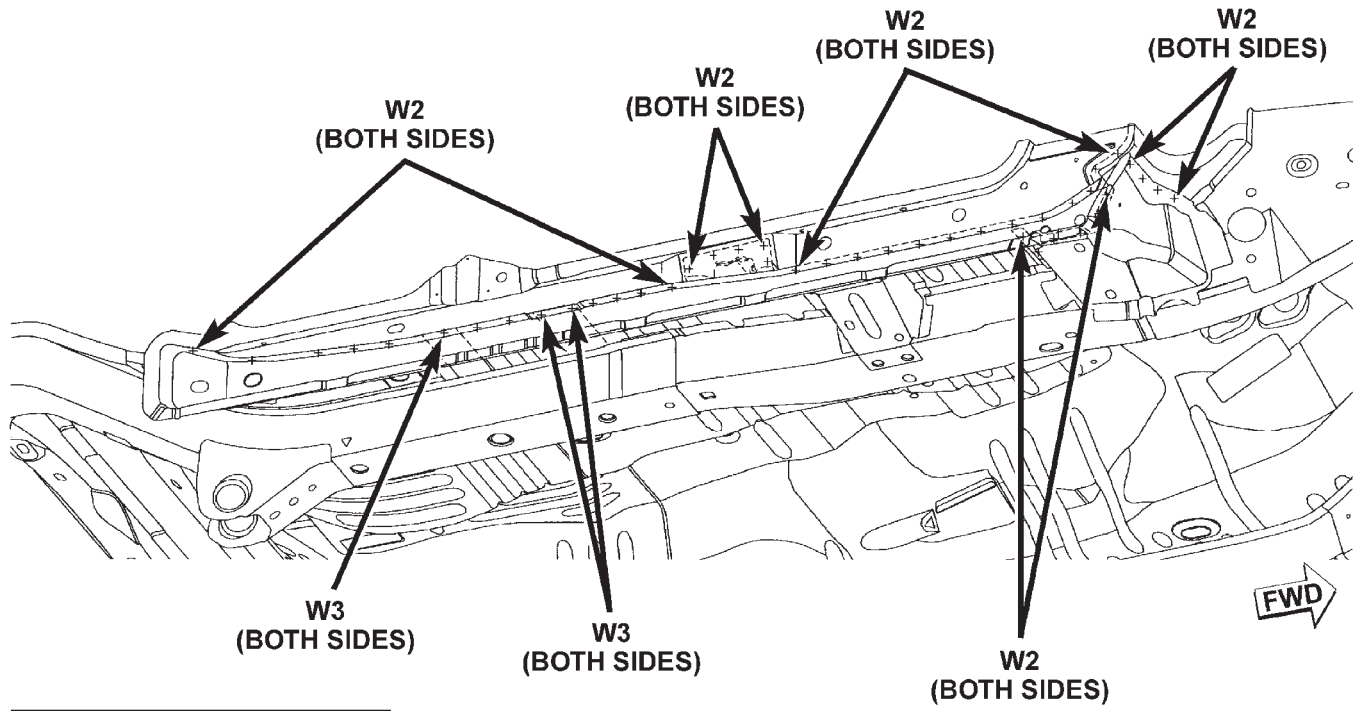

W2 - WELDING OF 2 PARTS
W3 - WELDING OF 3 PARTS
W4 - WELDING OF 4 PARTS

SPECIFICATIONS (Continued)

REAR RAILS TO REAR CROSSMEMBER

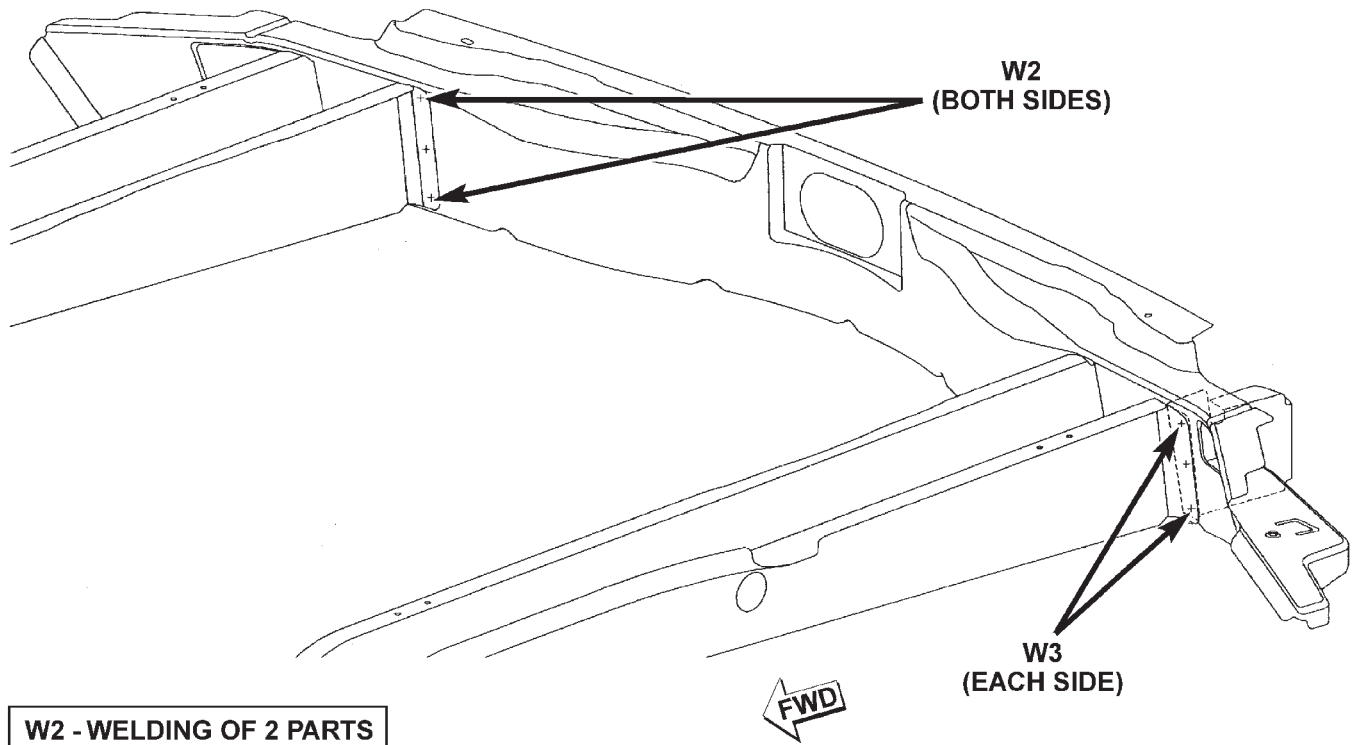

W2 - WELDING OF 2 PARTS
W3 - WELDING OF 3 PARTS
W4 - WELDING OF 4 PARTS

SPECIFICATIONS (Continued)

INNER WHEELHOUSE TO FLOOR PAN

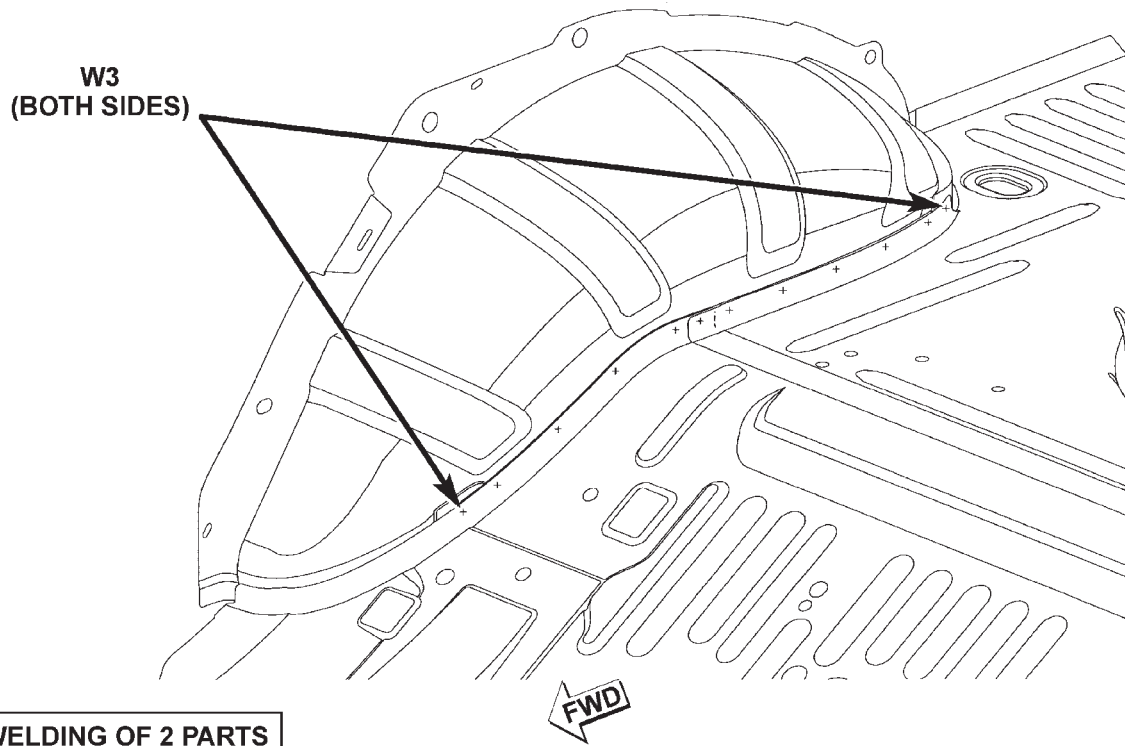

W2 - WELDING OF 2 PARTS
W3 - WELDING OF 3 PARTS
W4 - WELDING OF 4 PARTS

SPECIFICATIONS (Continued)

INNER WHEELHOUSE TO INNER BODYSIDE
APERTURE AND FLOOR PAN

W2 - WELDING OF 2 PARTS
W3 - WELDING OF 3 PARTS
W4 - WELDING OF 4 PARTS

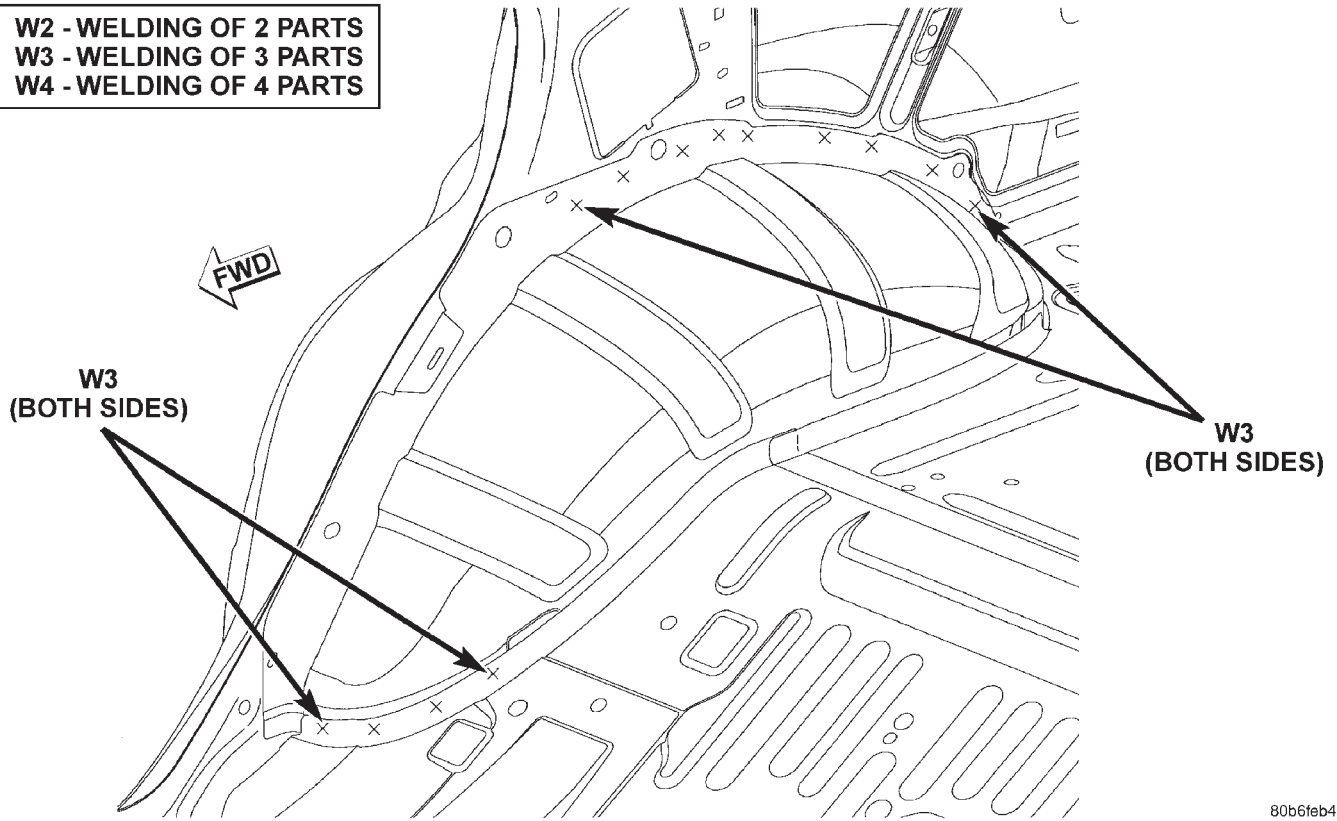

80b6feb4

SPECIFICATIONS (Continued)

OUTER WHEELHOUSE TO OUTER BODYSIDE APERTURE

W2 - WELDING OF 2 PARTS
W3 - WELDING OF 3 PARTS
W4 - WELDING OF 4 PARTS

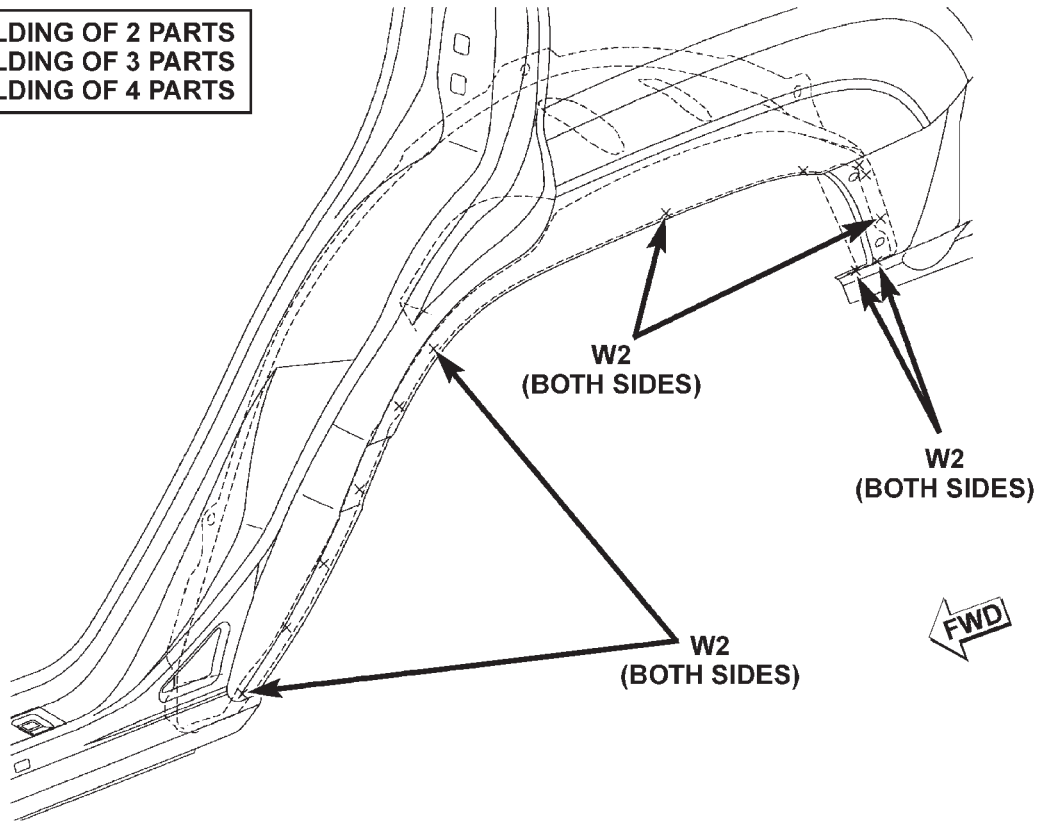

80b6feb5

SPECIFICATIONS (Continued)

OUTER WHEELHOUSE TO INNER BODYSIDE APERTURE

W2 - WELDING OF 2 PARTS
W3 - WELDING OF 3 PARTS
W4 - WELDING OF 4 PARTS

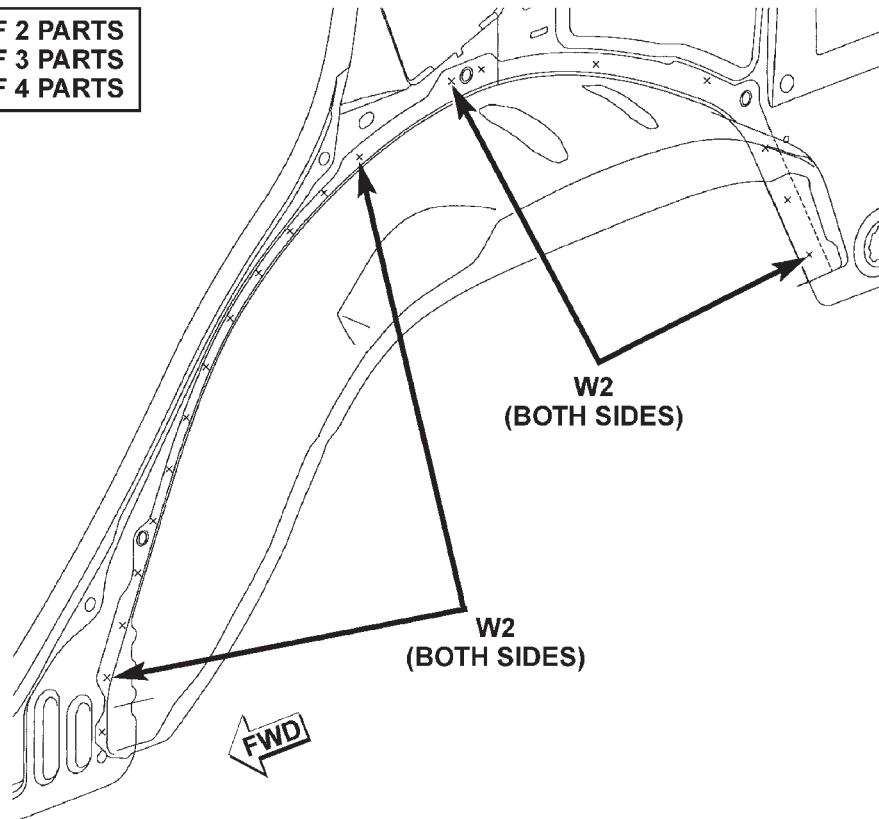

SPECIFICATIONS (Continued)

**INNER BODYSIDE APERTURE TO OUTER
BODYSIDE APERTURE**

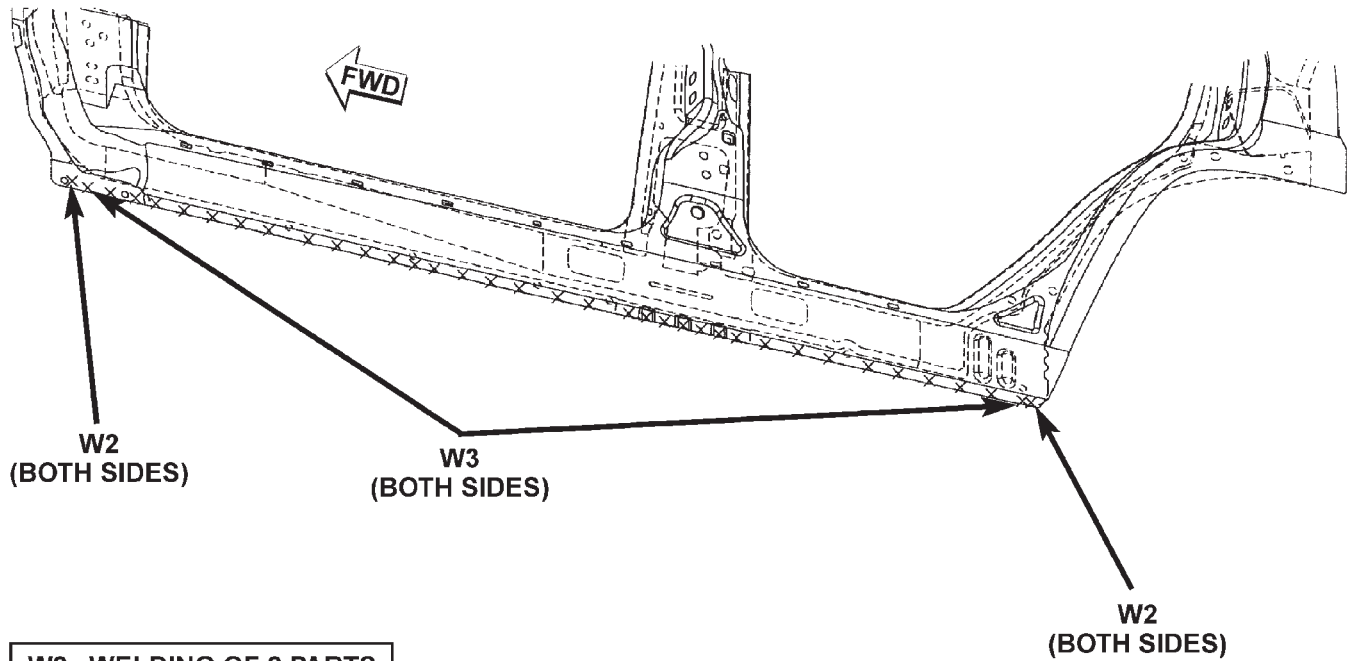

**W2 - WELDING OF 2 PARTS
W3 - WELDING OF 3 PARTS
W4 - WELDING OF 4 PARTS**

SPECIFICATIONS (Continued)

REAR INBOARD SEAT BELT REINFORCEMENT TO FLOOR PAN

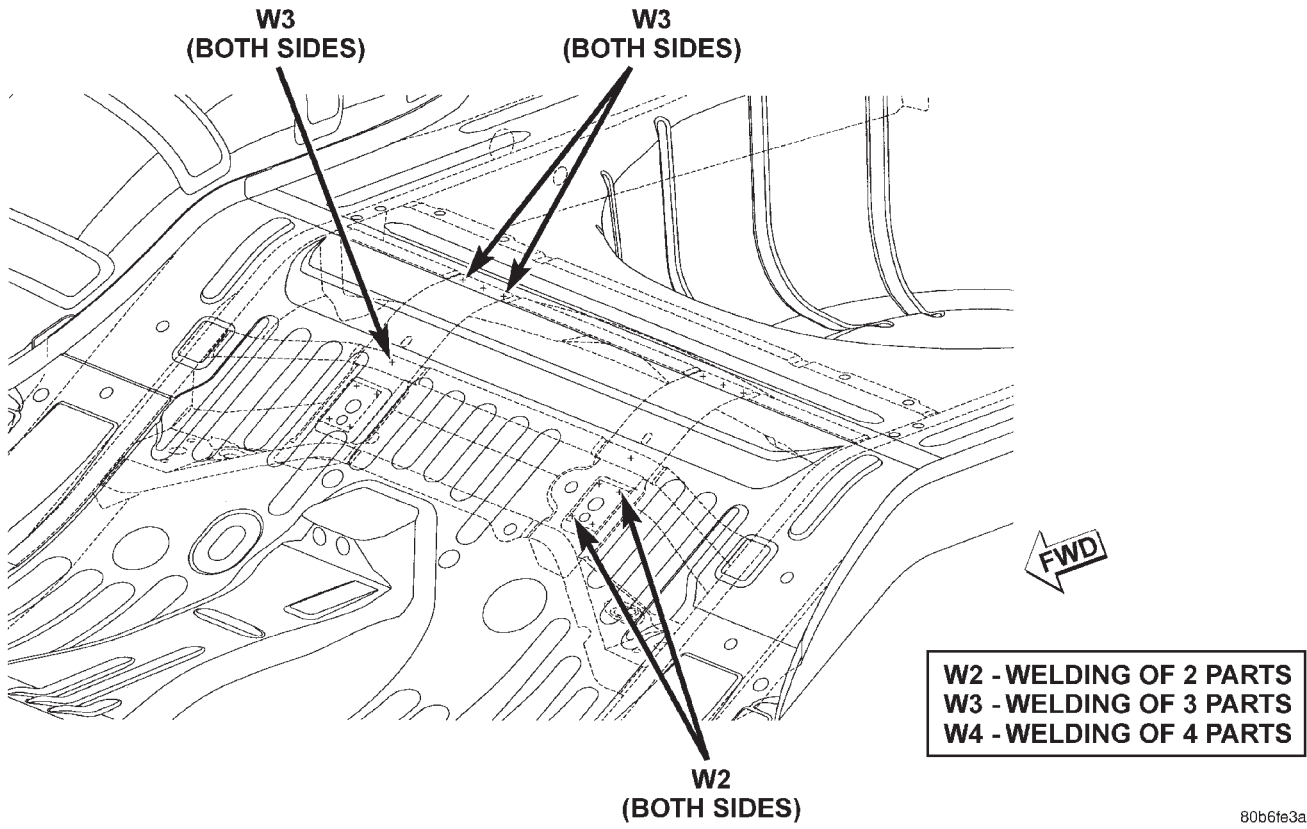

SPECIFICATIONS (Continued)

SEALER LOCATIONS

APPLICATION METHODS

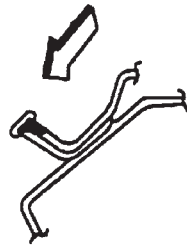

HOLD GUN NOZZLE IN DIRECTION OF ARROW IN ORDER TO EFFECTIVELY SEAL METAL JOINTS.

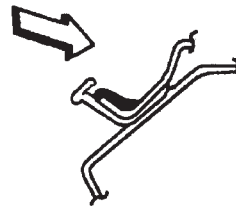

DO NOT HOLD GUN NOZZLE IN DIRECTION OF ARROW. SEALER APPLIED AS SHOWN IN INEFFECTIVE.

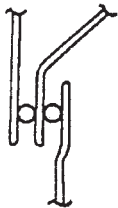

3 METAL THICKNESS

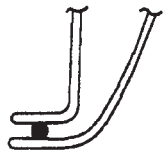

2 METAL THICKNESS

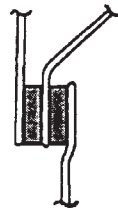

3 METAL THICKNESS

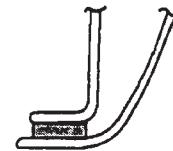

2 METAL THICKNESS

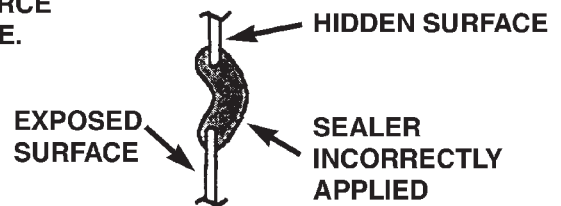
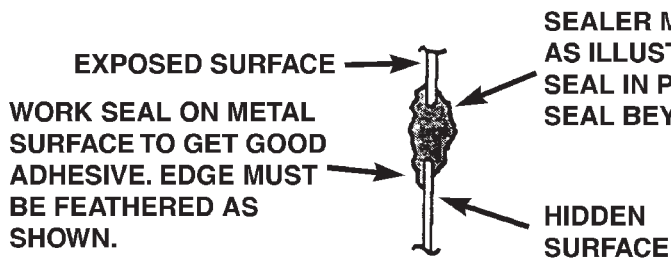

SYMBOLS	
	THUMBGRADEABLE SEALER
	EXTRUDABLE THERMOPLASTIC
	EXPOSED THERMOPLASTIC SEALANT
	HIDDEN SEALANT

SPECIFICATIONS (Continued)

COWL PLENUM AND DASH PANEL

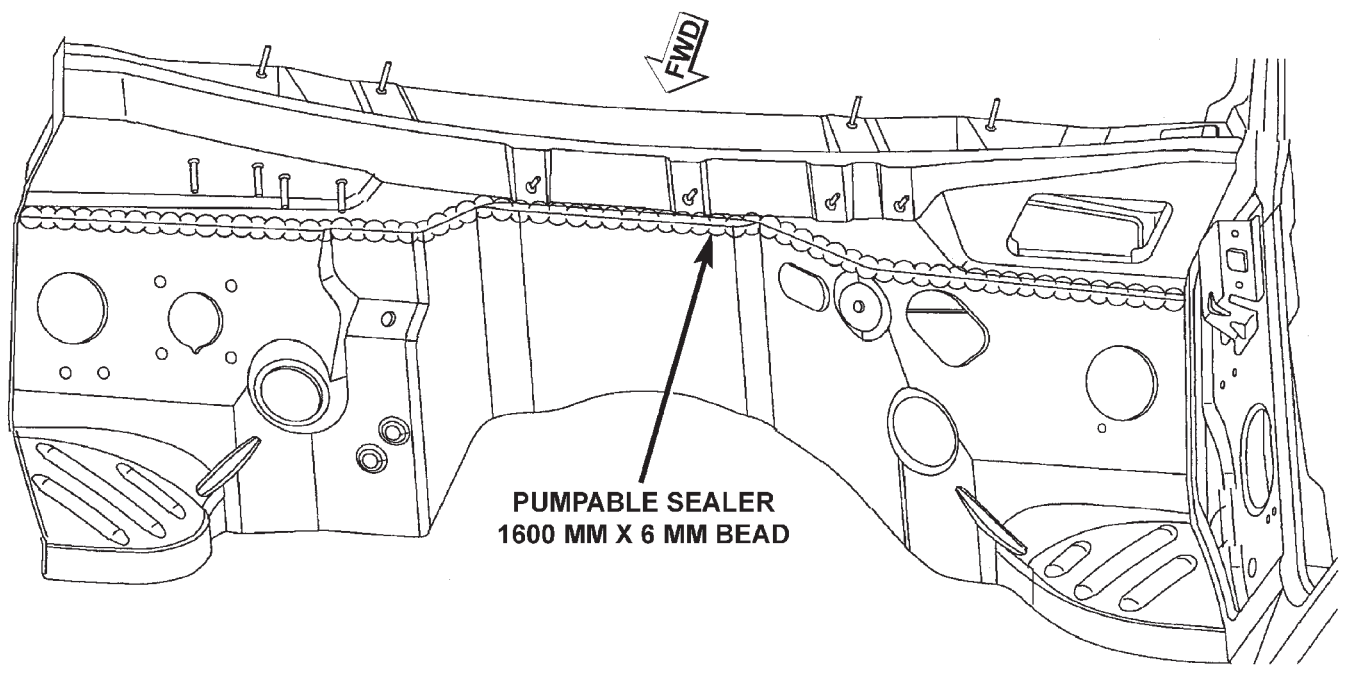

**PUMPABLE SEALER
1600 MM X 6 MM BEAD**

SPECIFICATIONS (Continued)

DASH, COWL AND PLENUM

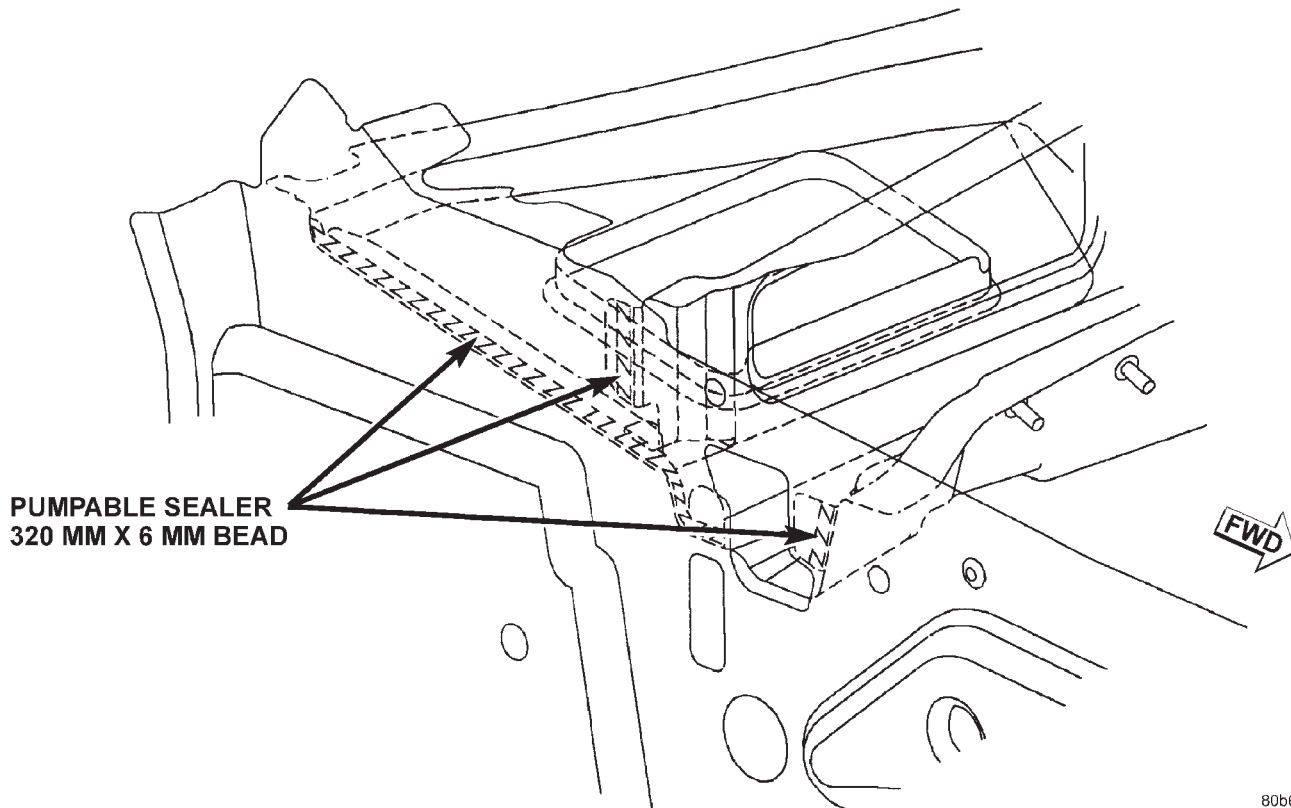
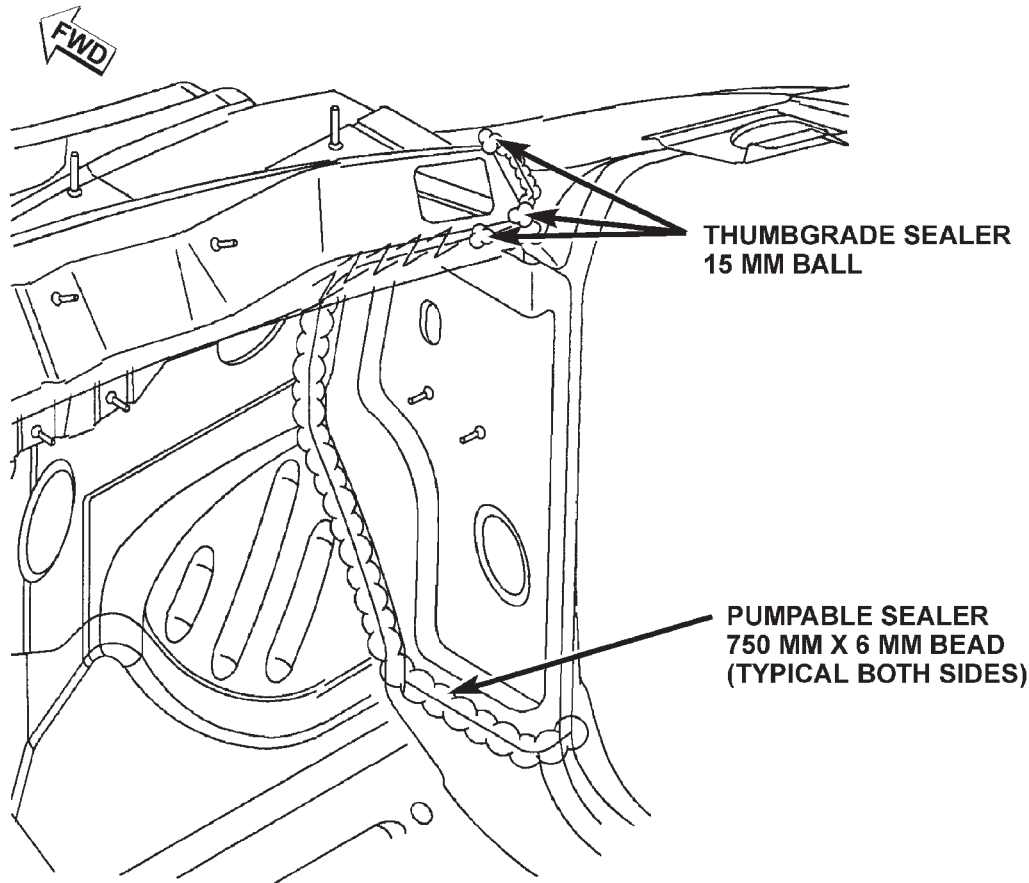

SPECIFICATIONS (Continued)

INNER FENDER AND COWL

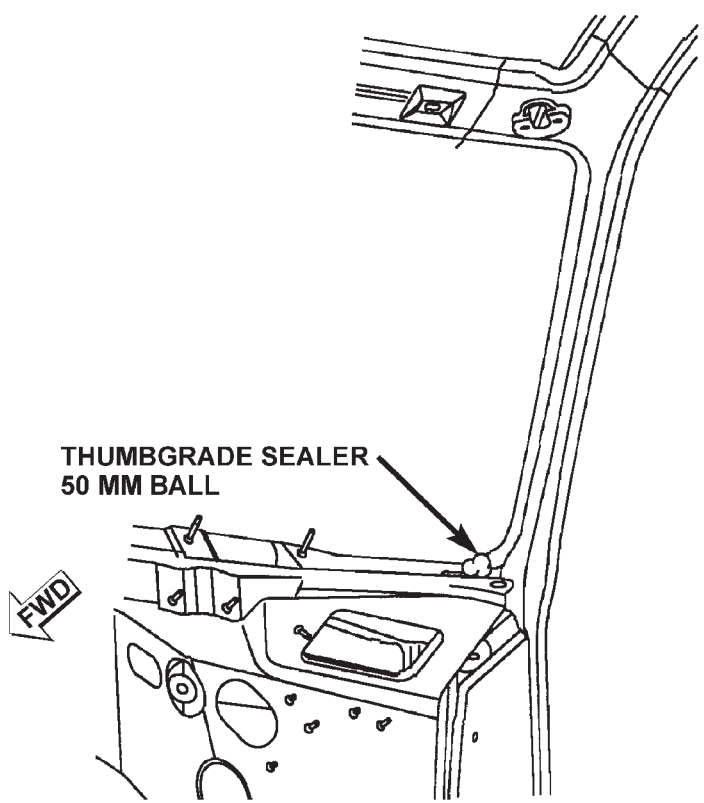
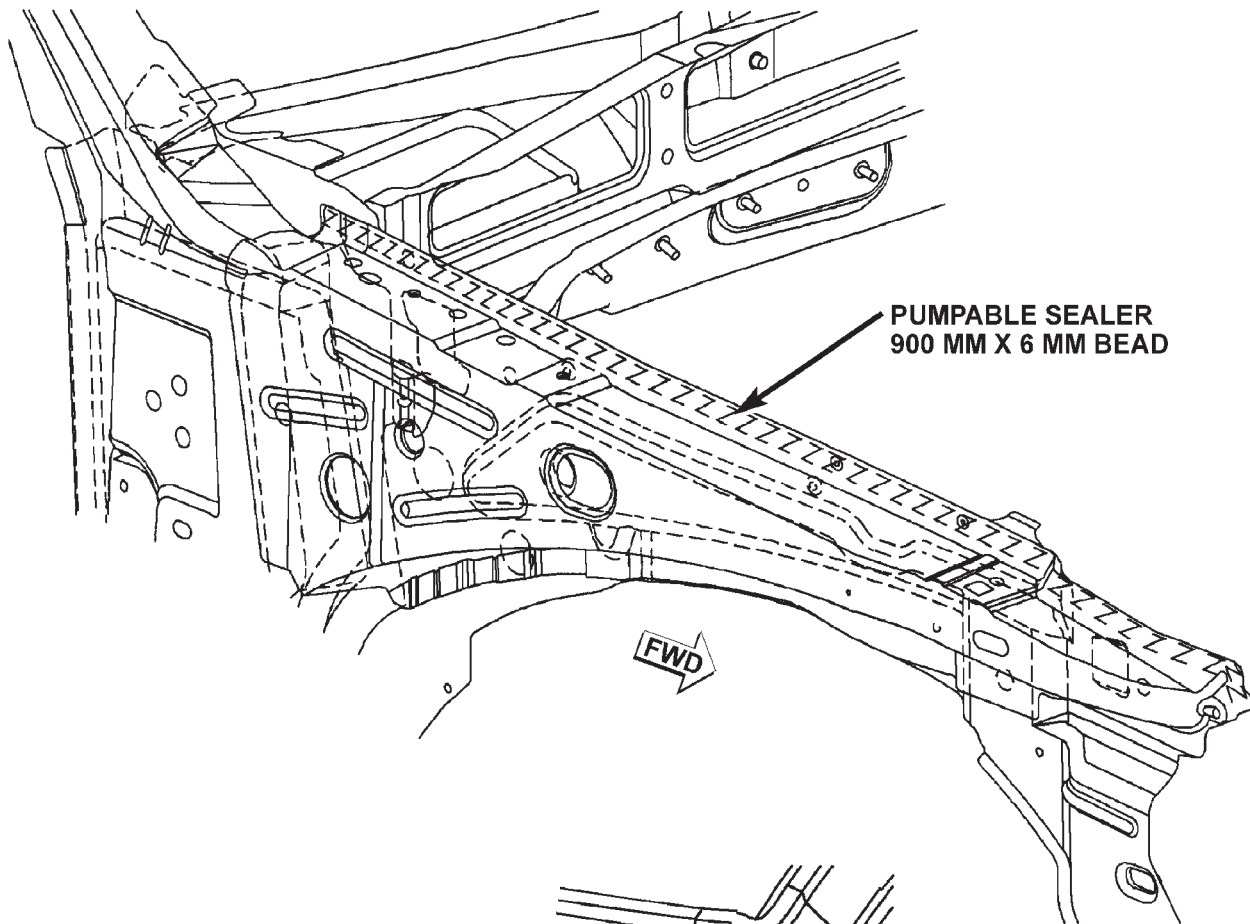

SPECIFICATIONS (Continued)

LOWER PLENUM AND BAFFLE

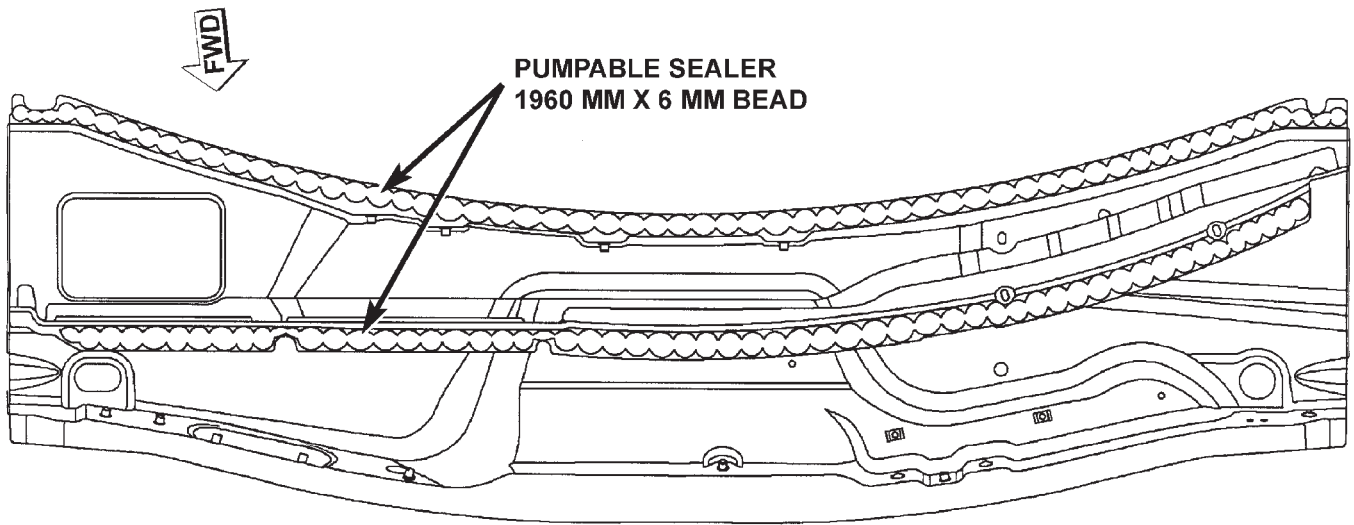

**APPLY TO PLENUM LOWER REAR FLANGE
AND PLENUM BAFFLE FLANGE.**

SPECIFICATIONS (Continued)

A-PILLAR

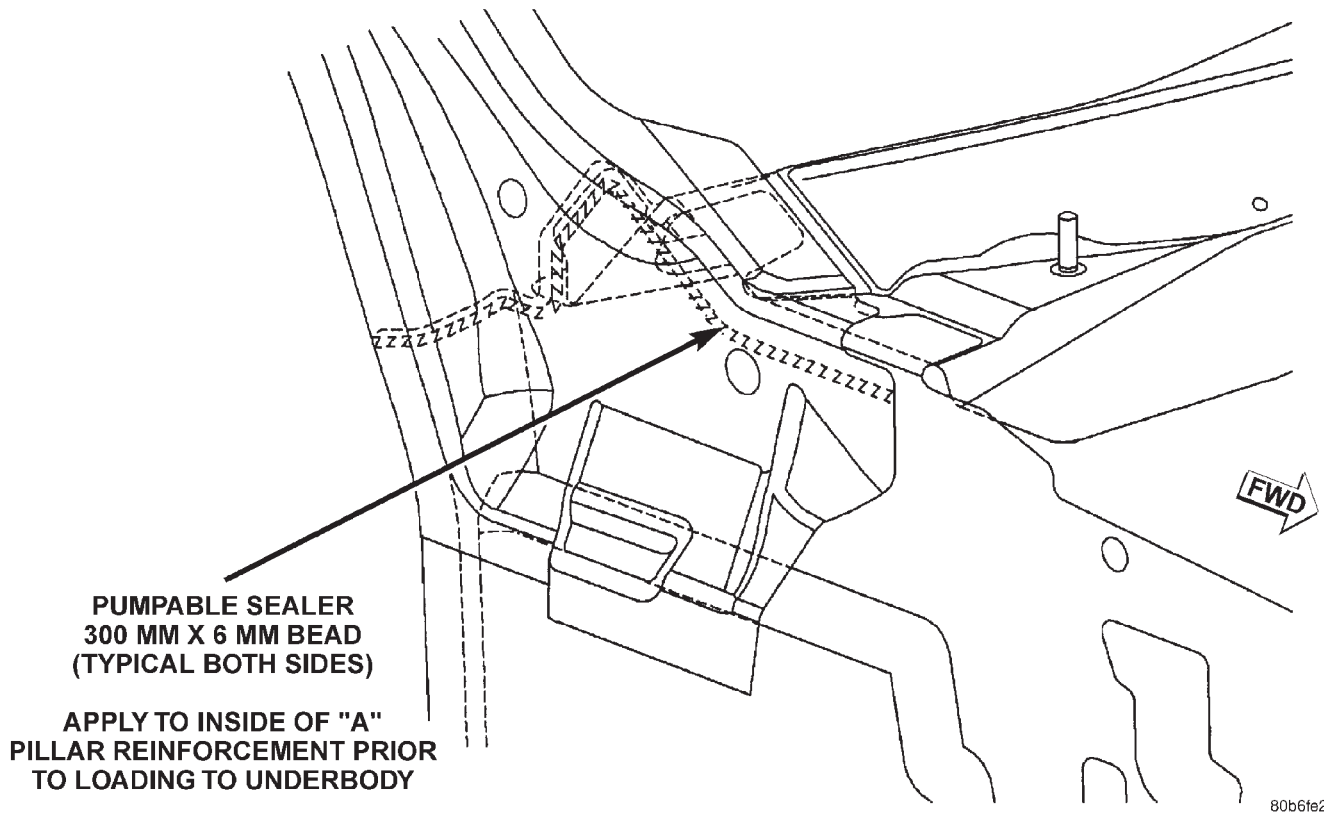

SPECIFICATIONS (Continued)

COWL SIDE ATTACHMENT

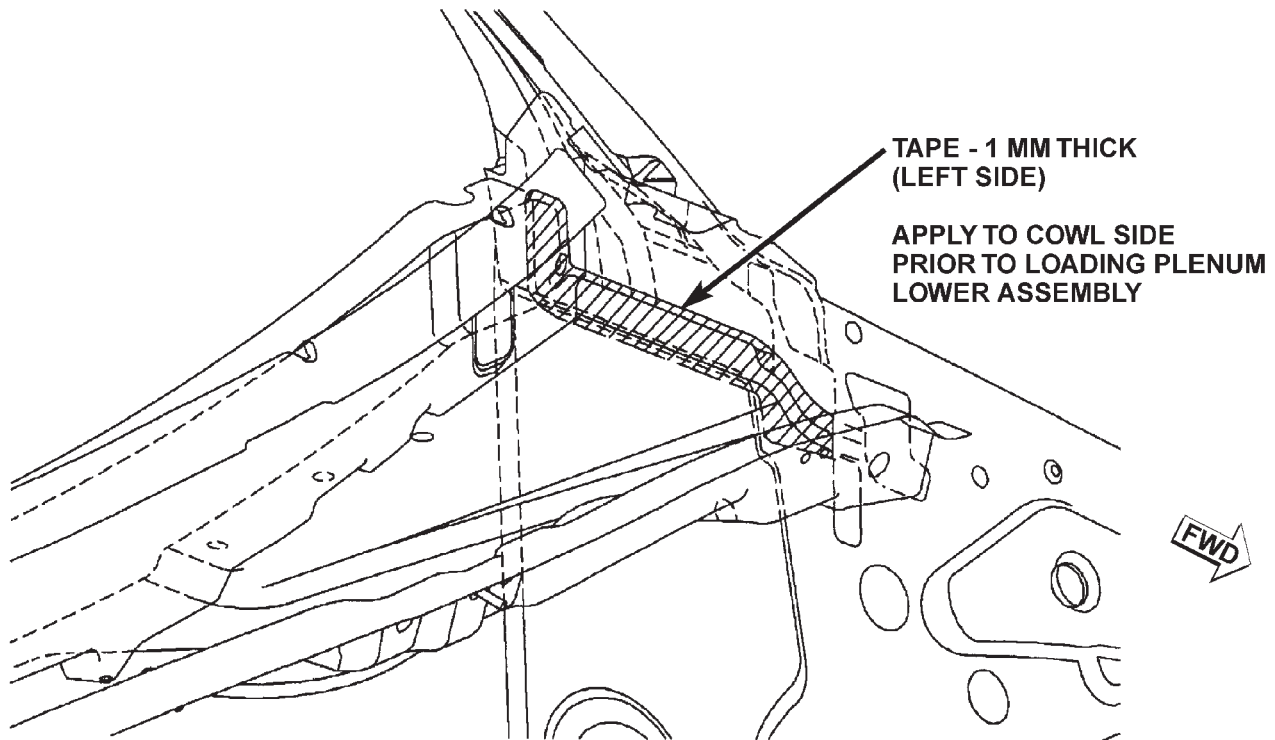
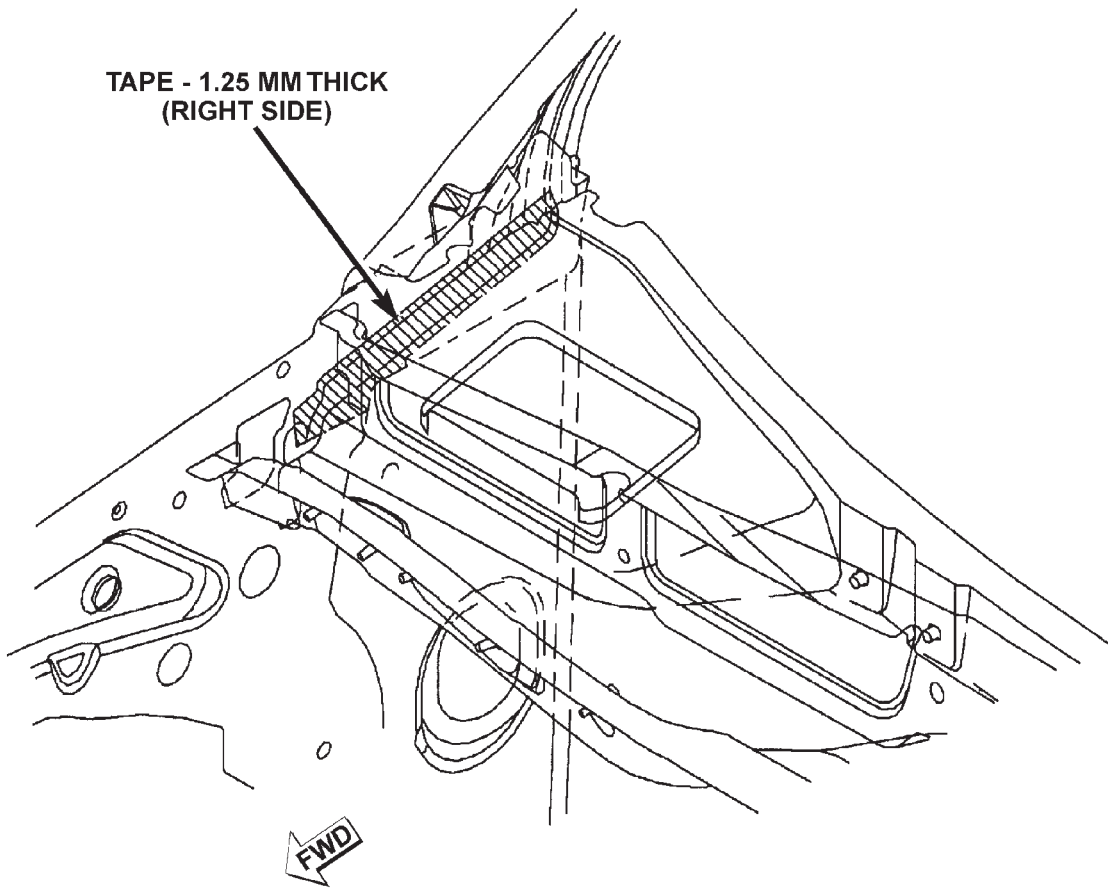

SPECIFICATIONS (Continued)

BODYSIDE ATTACHMENT

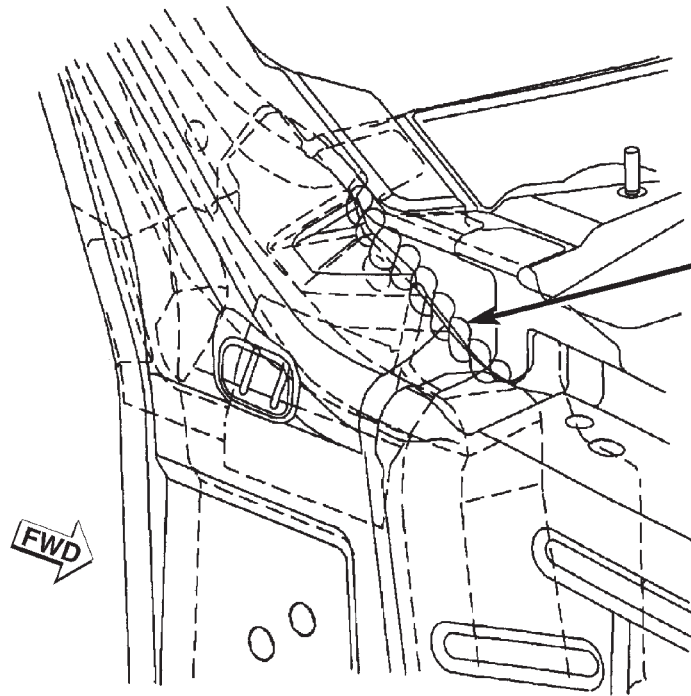

**THUMBGRADE ROPE
150 MM X 9 MM BALL
(TYPICAL BOTH SIDES)**

**APPLY TO BODYSIDE ASSEMBLY
PRIOR TO SPRAY SEALER
APPLICATION**

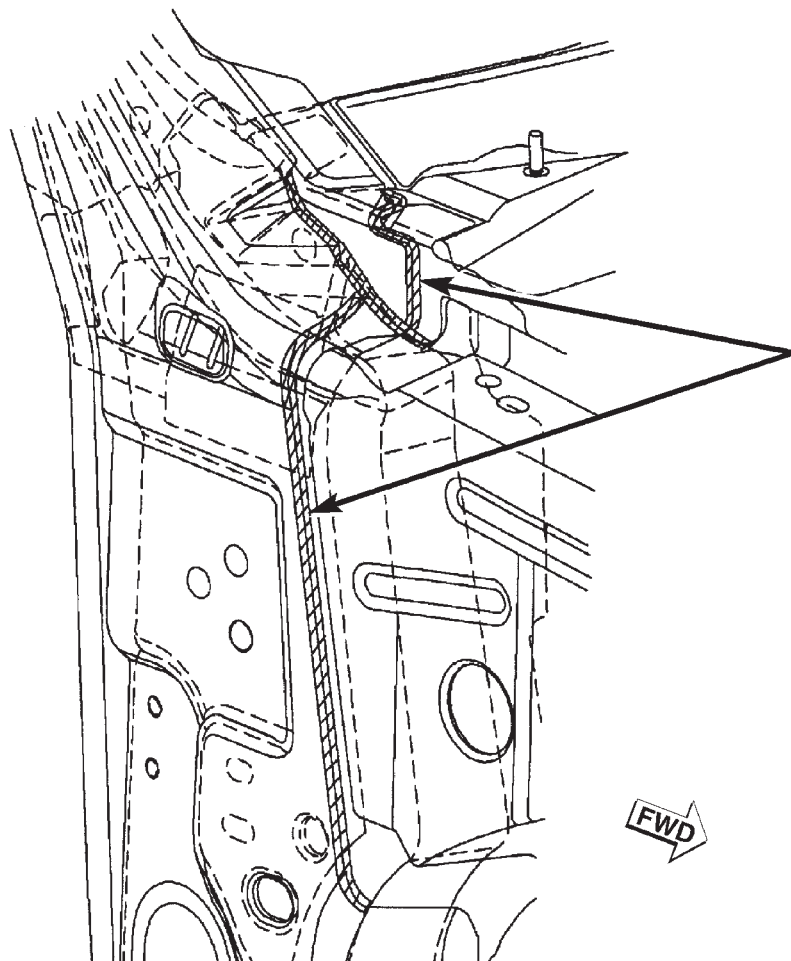

**SPRAYABLE ADHESIVE
(TYPICAL BOTH SIDES)**

**APPLY AFTER MIG WELDS BUT
PRIOR TO FENDER INSTALLATION**

SPECIFICATIONS (Continued)

BODYSIDE INNER AND OUTER TO COWL

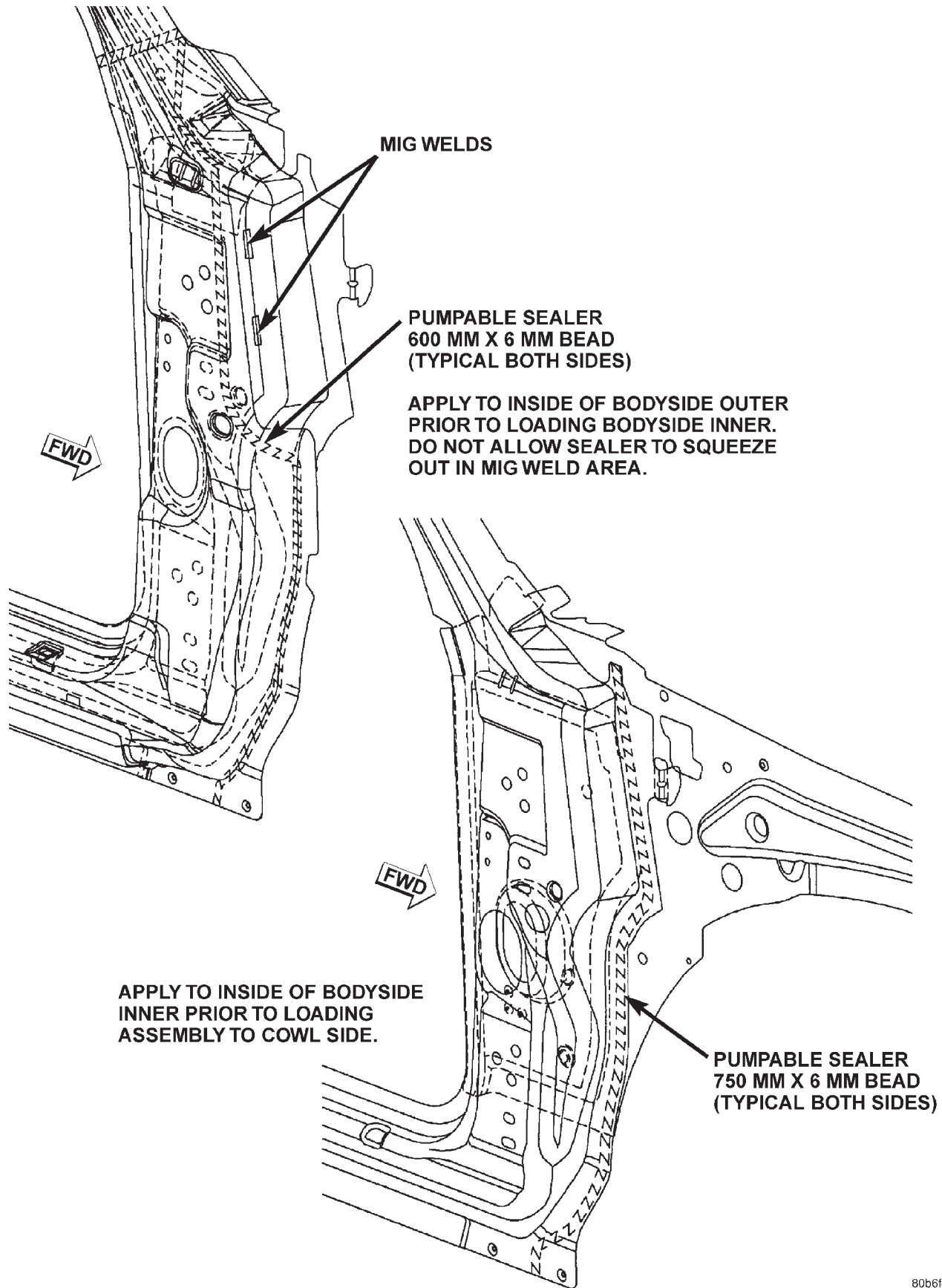

SPECIFICATIONS (Continued)

FENDER ATTACHMENT

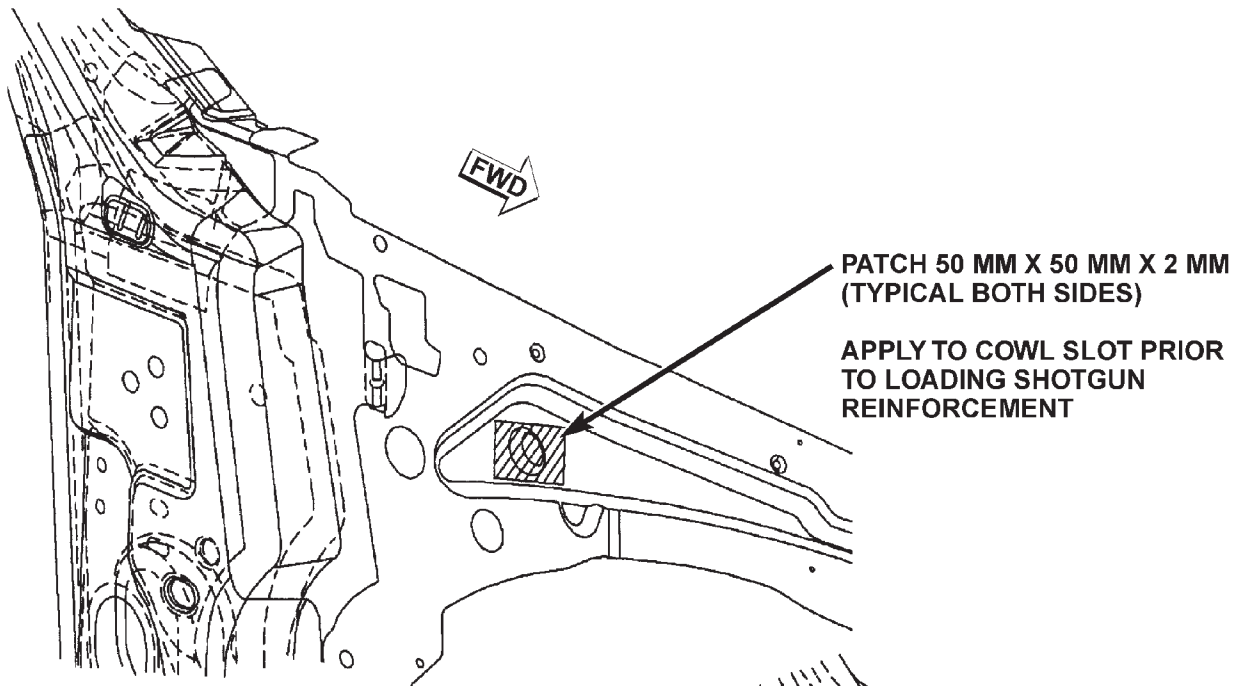

**45 MM X 30 MM X 1.25 MM PATCH
(TYPICAL BOTH SIDES)**

**APPLY ON TOP OF FENDER
ATTACHING SLOTS PRIOR TO
ATTACHING FENDER BRACKETS**

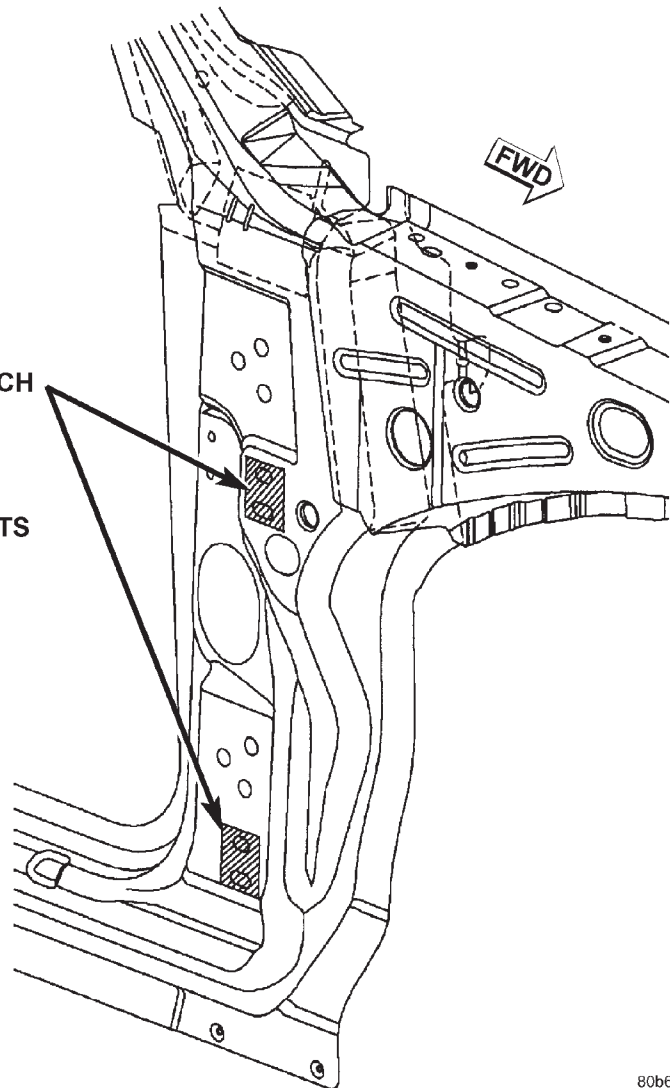

SPECIFICATIONS (Continued)

DOOR HINGE BOLT HOLES

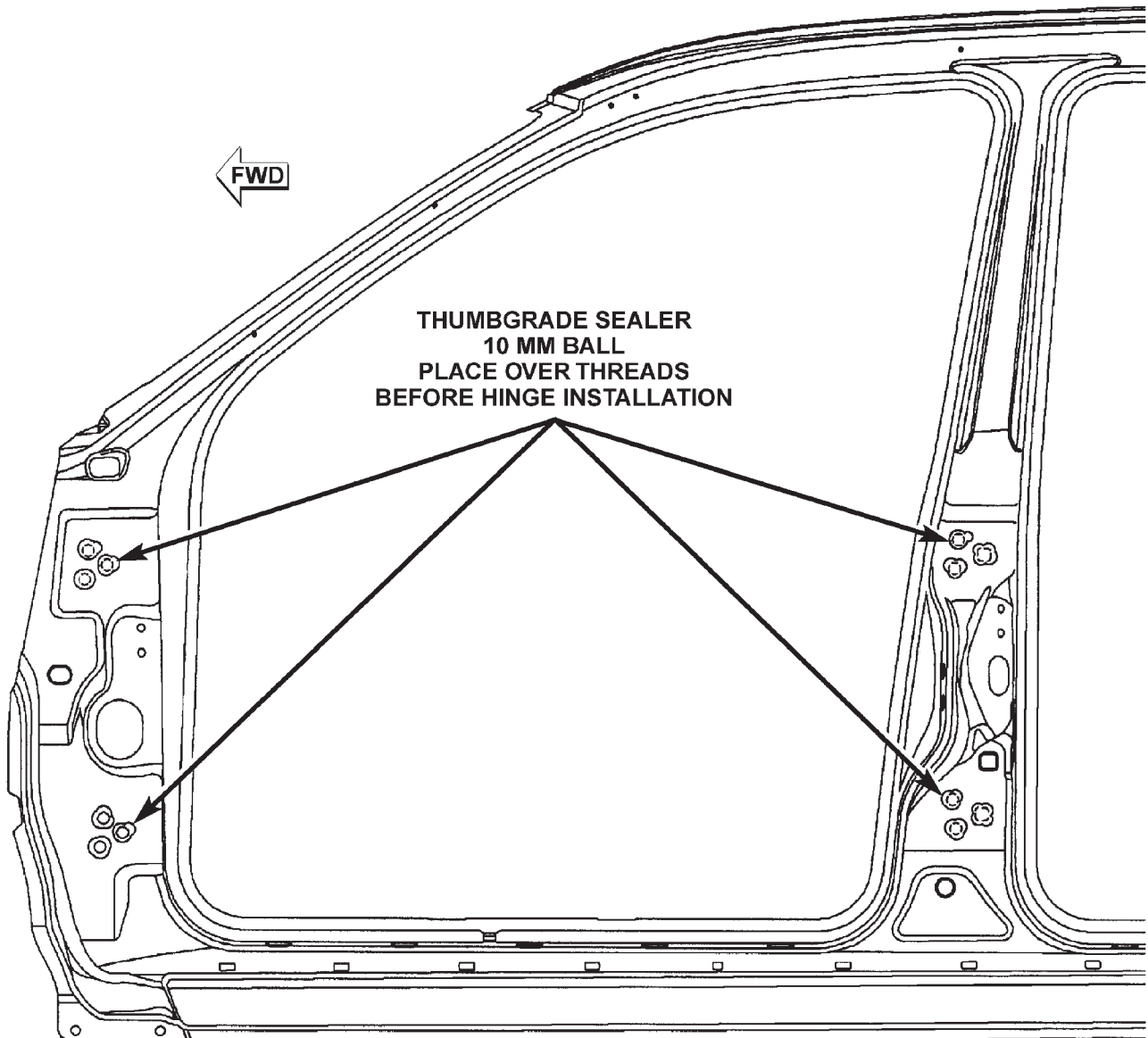

SPECIFICATIONS (Continued)

A-PILLAR AND B-PILLAR HINGE AREA

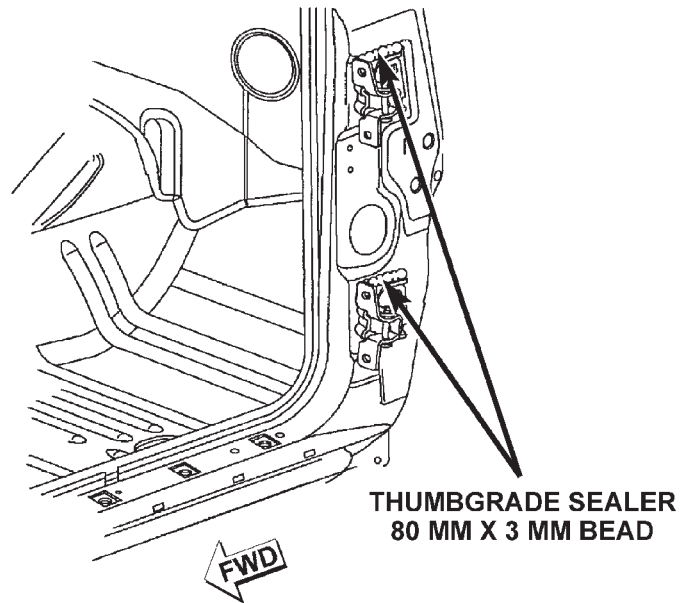
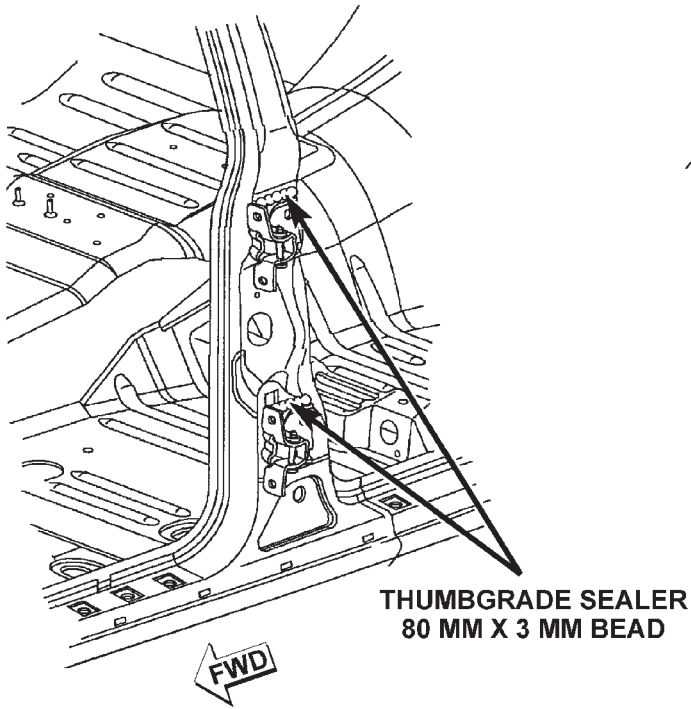

SPECIFICATIONS (Continued)

B-PILLAR AND SILL

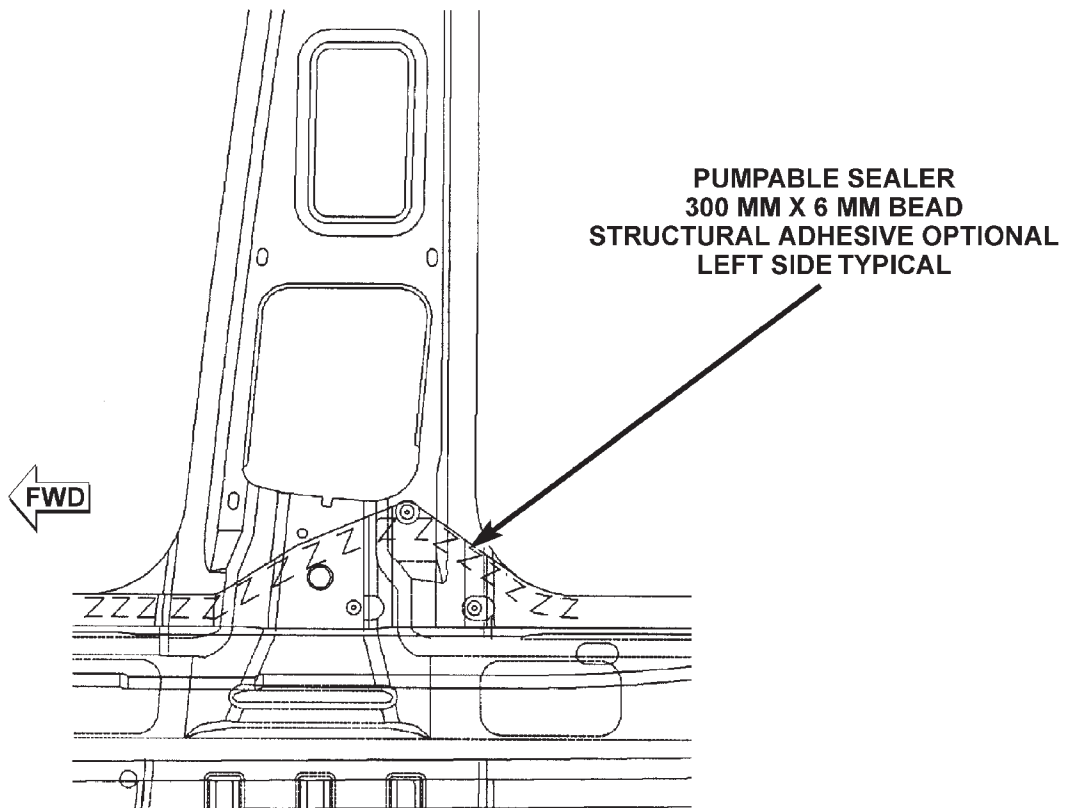
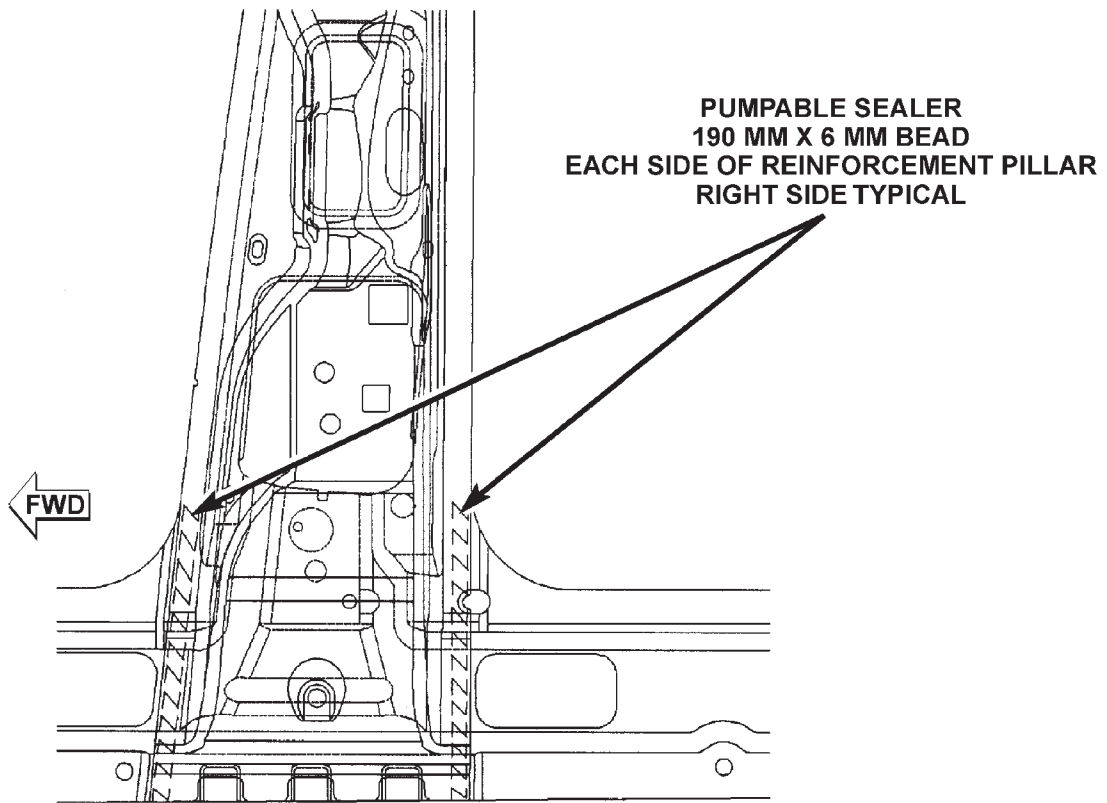

SPECIFICATIONS (Continued)

SILL AND B-PILLAR

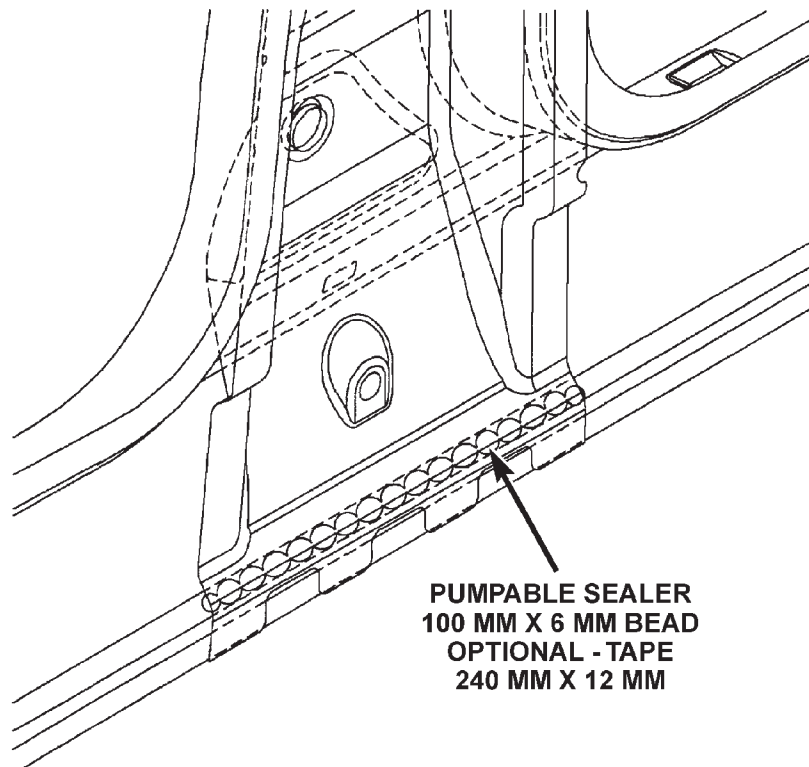
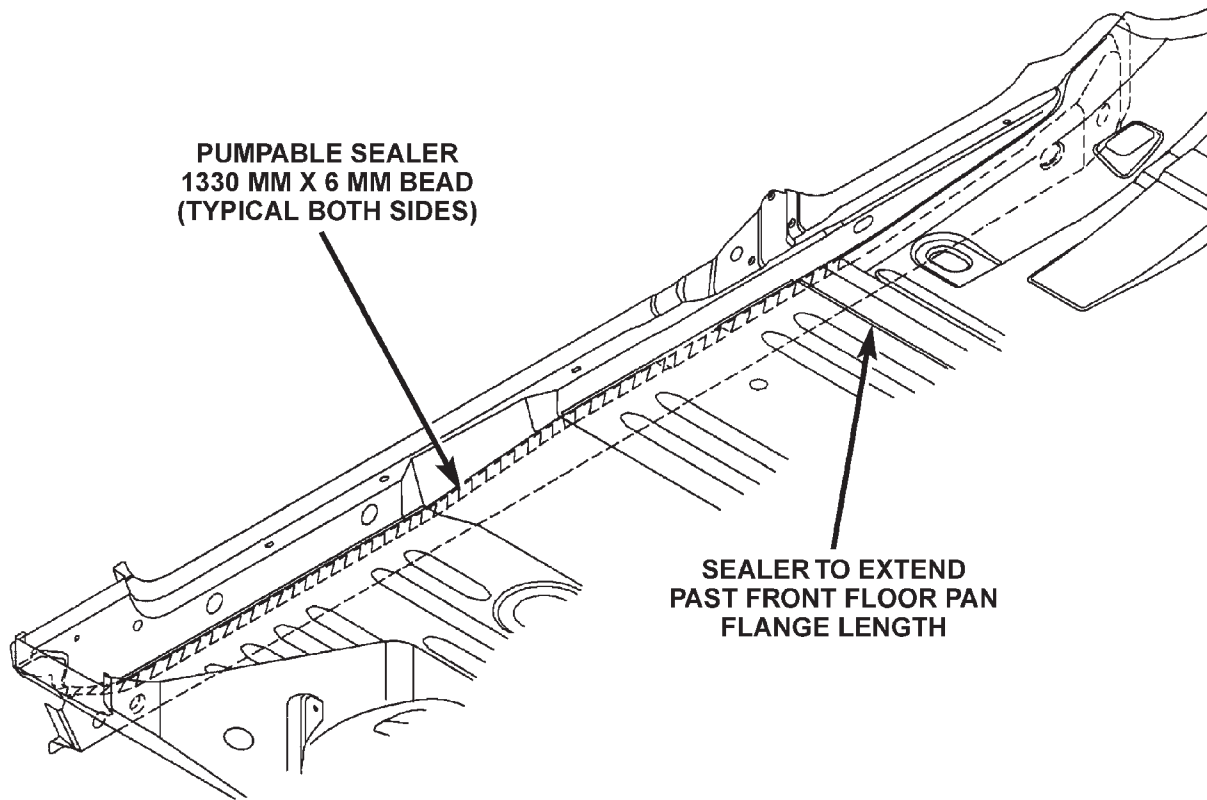

SPECIFICATIONS (Continued)

BODYSIDE APERTURE AND REAR WHEELHOUSE

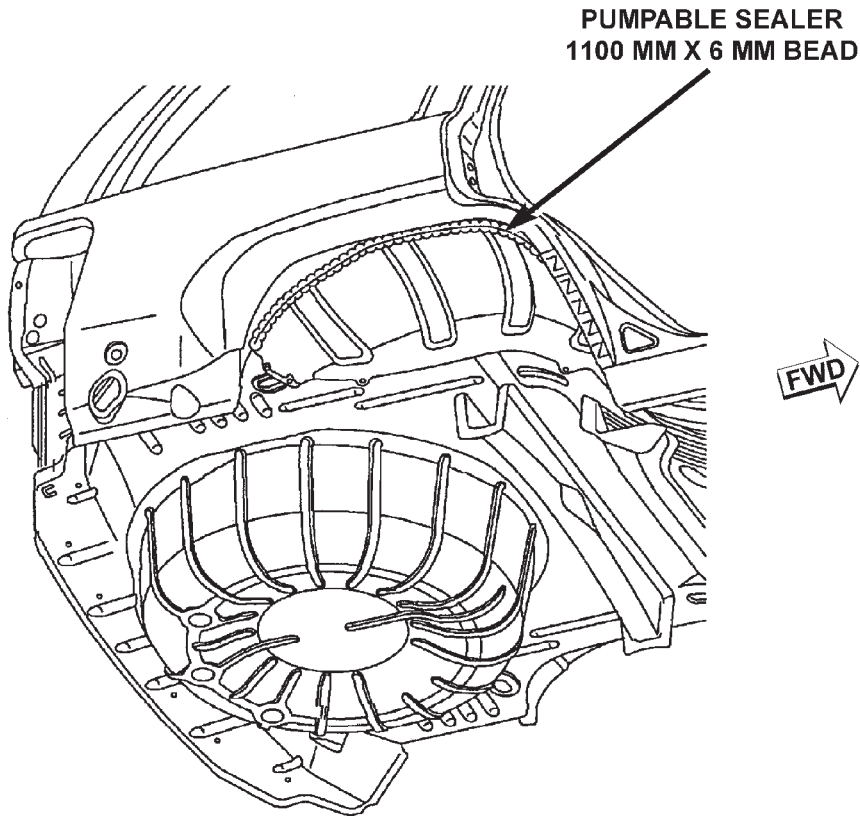

80b6fe21

SPECIFICATIONS (Continued)

FUEL FILLER GUSSET

**PUMPABLE SEALER
800 MM X 3 MM BEAD
BETWEEN APERTURE INNER
AND GUSSET**

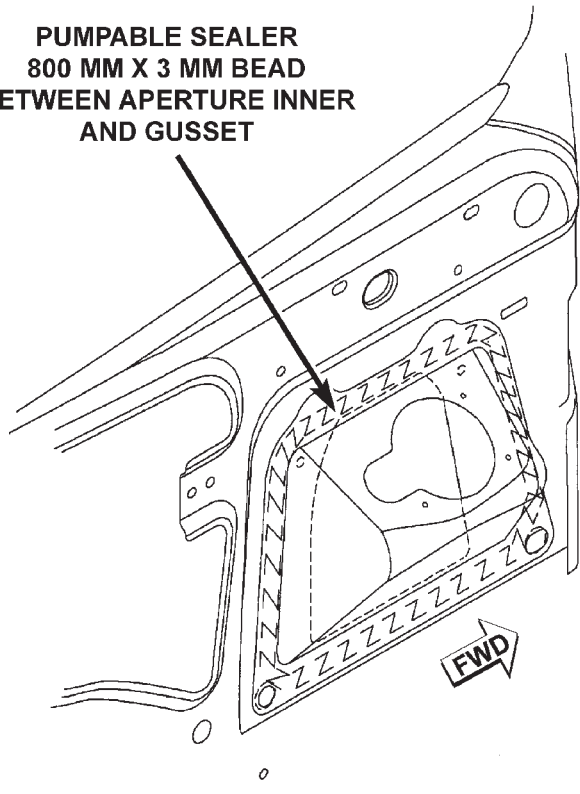

SPECIFICATIONS (Continued)

OUTER WHEELHOUSE FLANGE

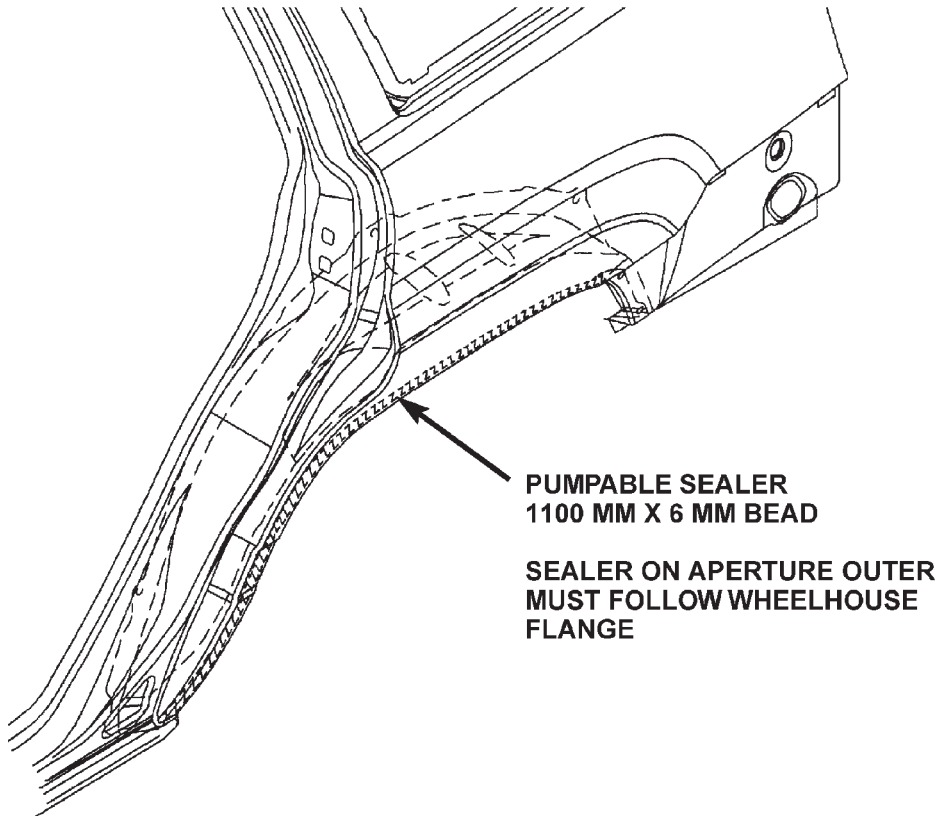

SPECIFICATIONS (Continued)

LIFTGATE OPENING

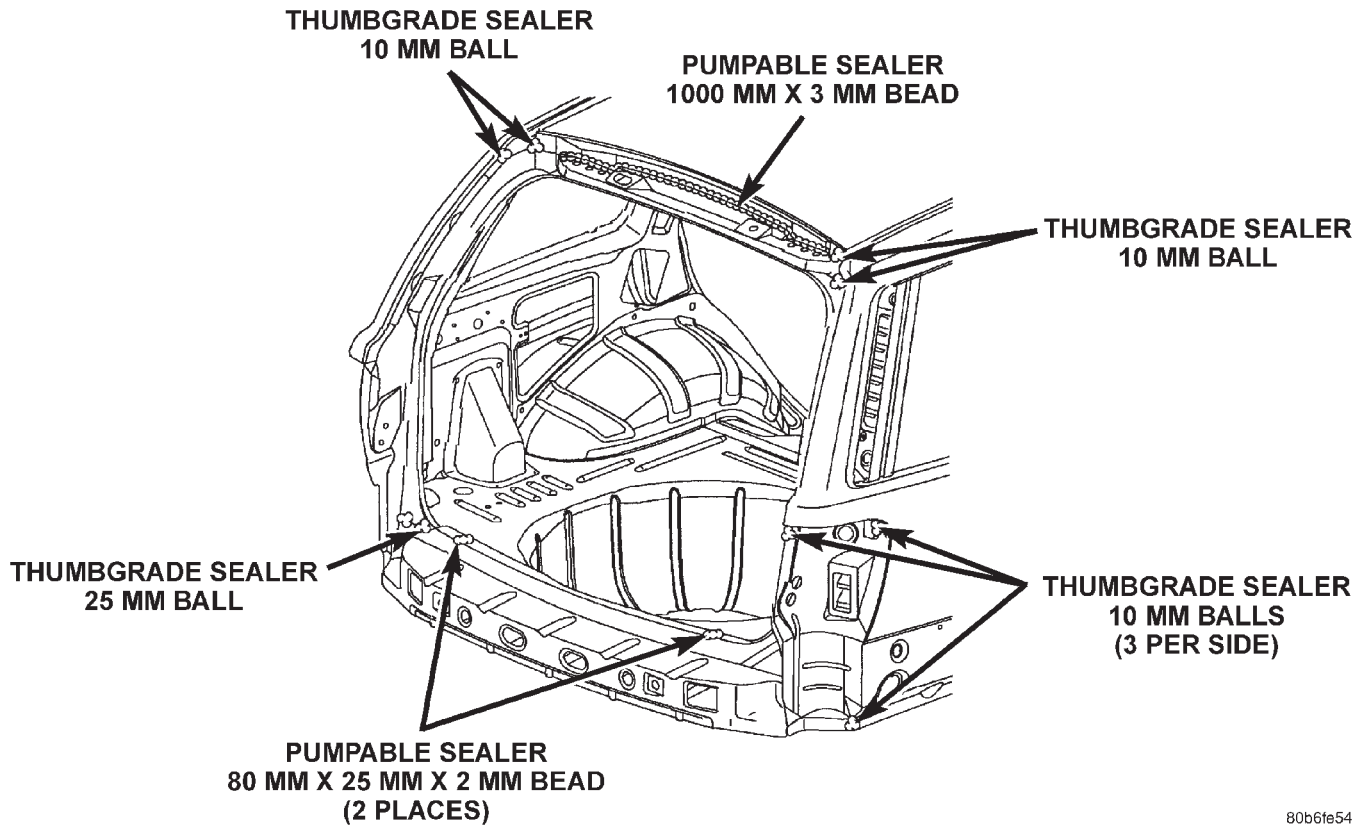

80b6te54

SPECIFICATIONS (Continued)

**INNER WHEELHOUSE FLANGE TO BODYSIDE
APERTURE**

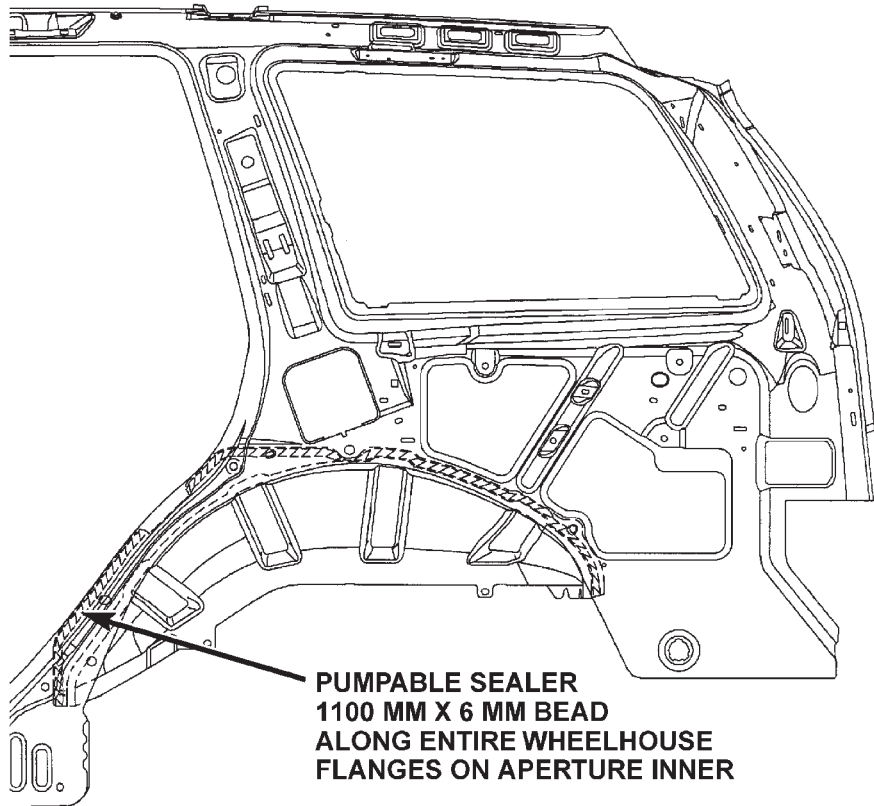

SPECIFICATIONS (Continued)

WHEELHOUSE LOWER

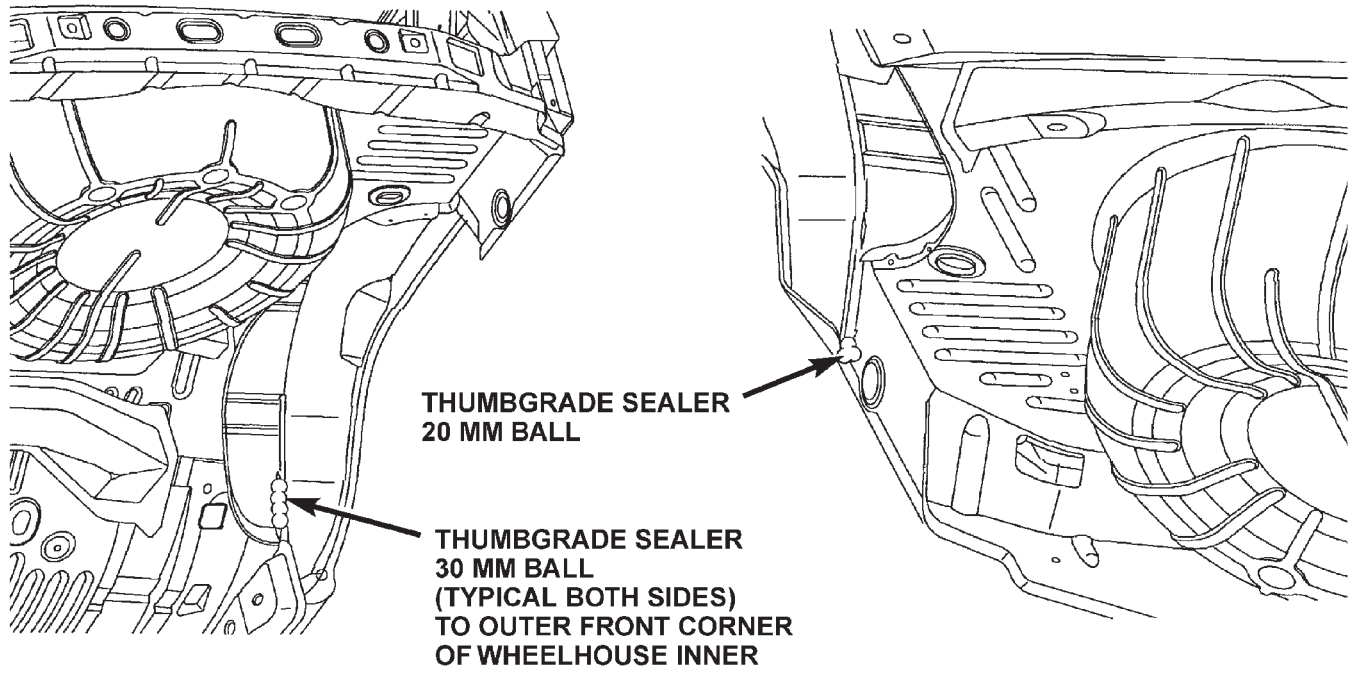

SPECIFICATIONS (Continued)

REAR INNER CROSSMEMBER

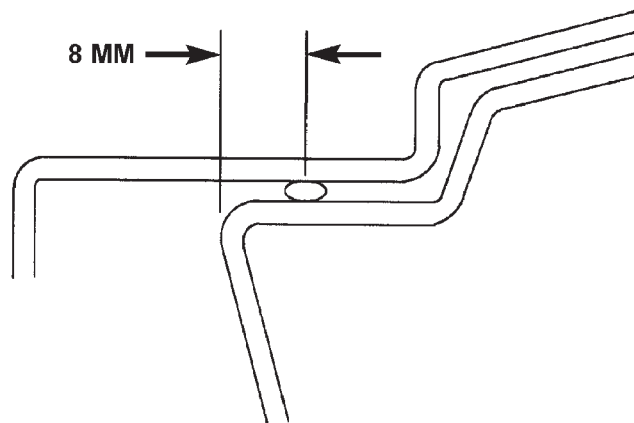
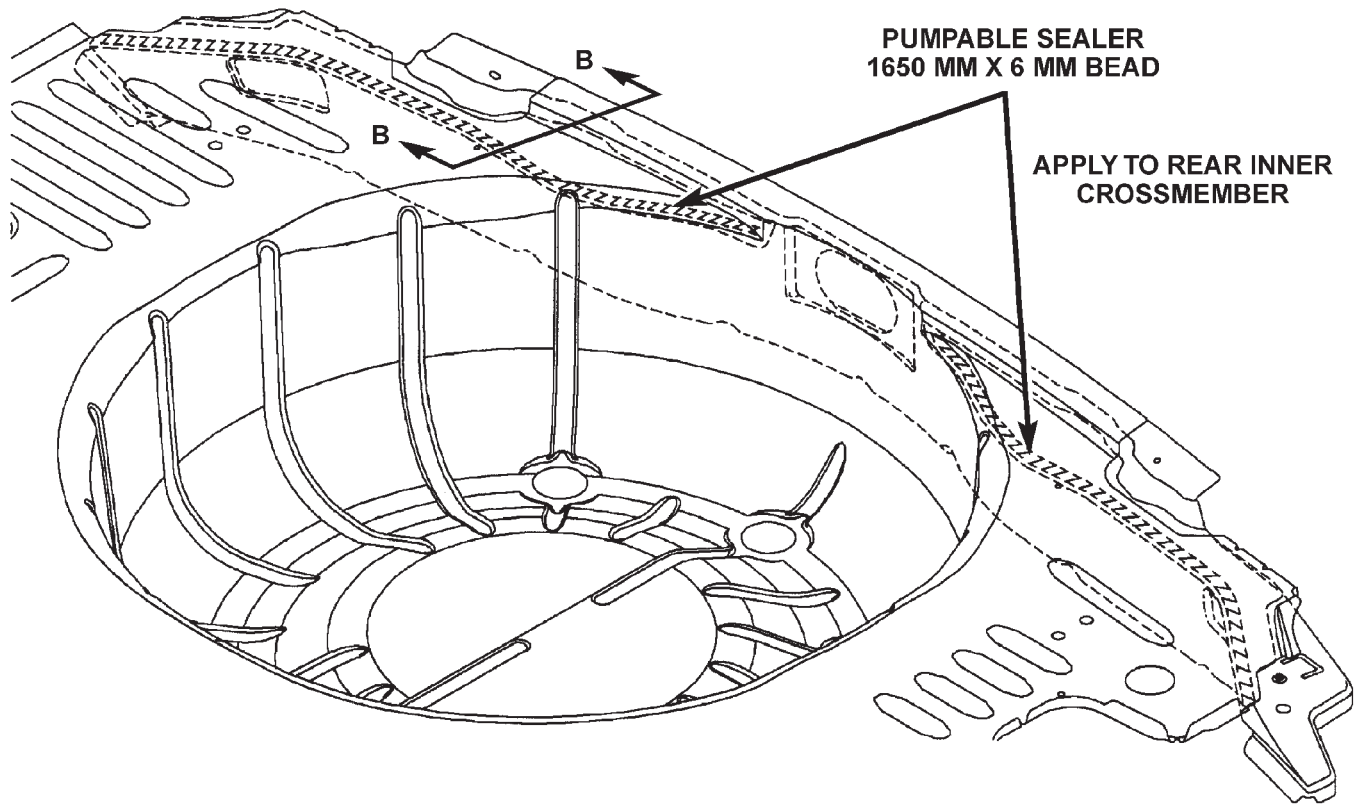

SECTION B - B

☉ OF SEALER BEAD
TO BE APPROXIMATELY 8 MM
REARWARD OF FRONT EDGE
OF REAR INNER CROSSMEMBER

SPECIFICATIONS (Continued)

ROOF TO BODY SIDE APERTURE

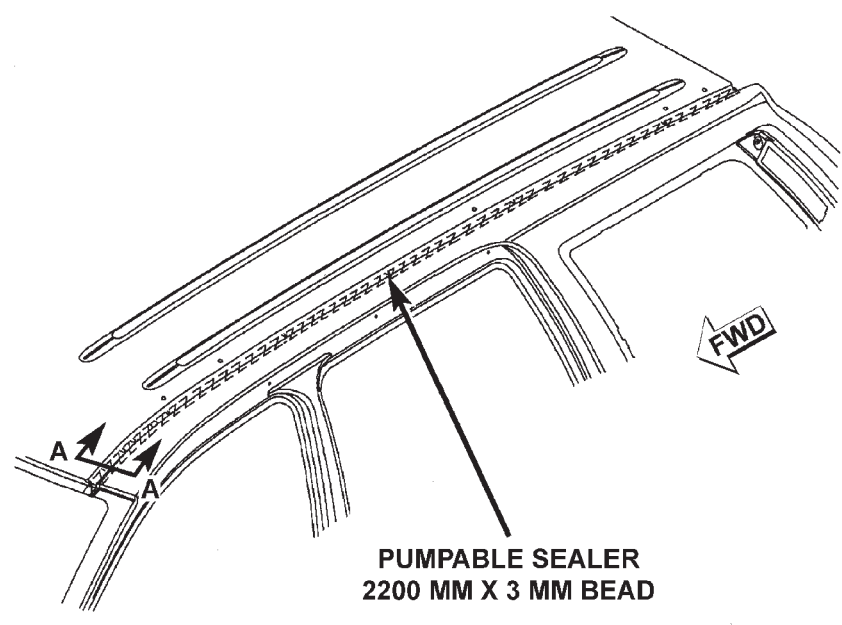

**PUMPABLE SEALER
2200 MM X 3 MM BEAD**

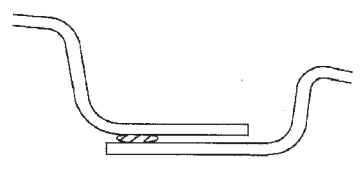

**SECTION A-A
(TYPICAL BOTH SIDES)**

SPECIFICATIONS (Continued)

STRUCTURAL ADHESIVE LOCATIONS

COWL PLENUM

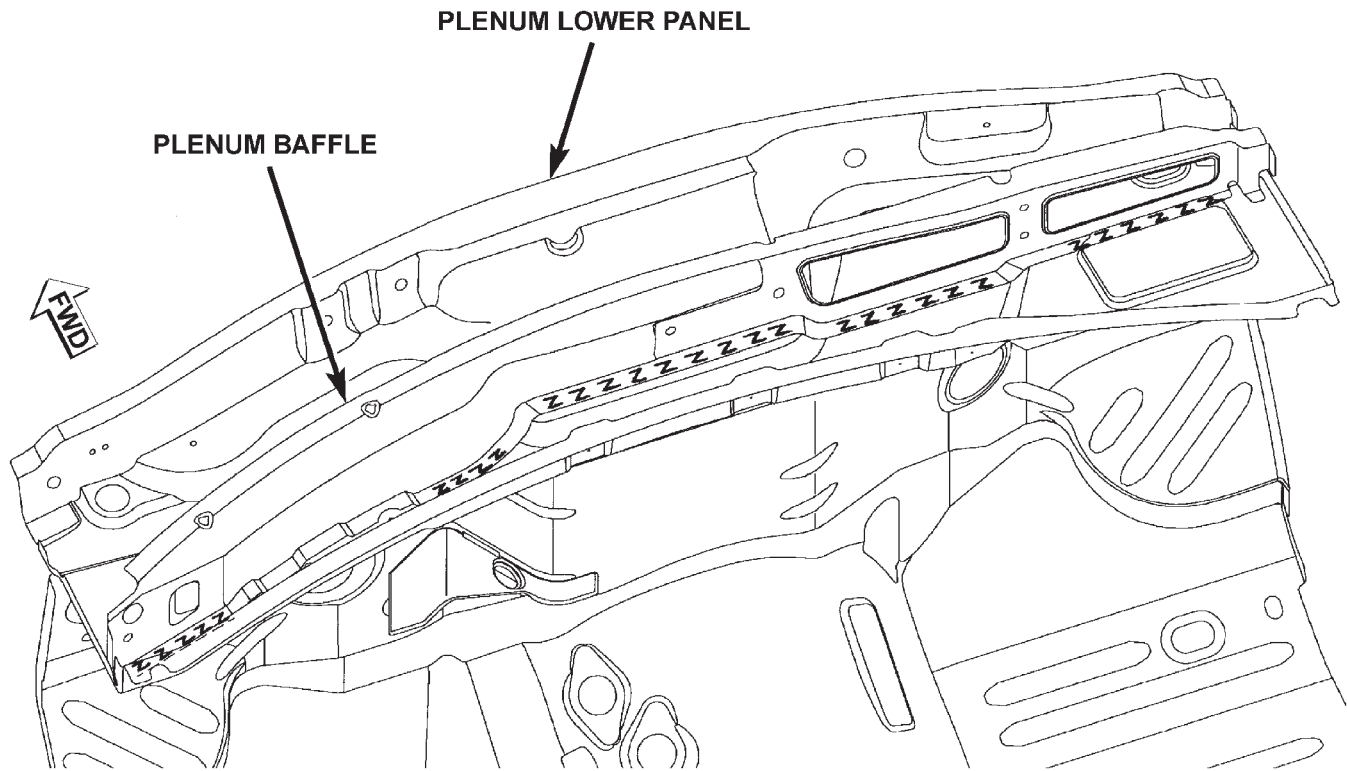

80b6fe97

SPECIFICATIONS (Continued)

DASH PANEL AND FRONT FLOOR PAN

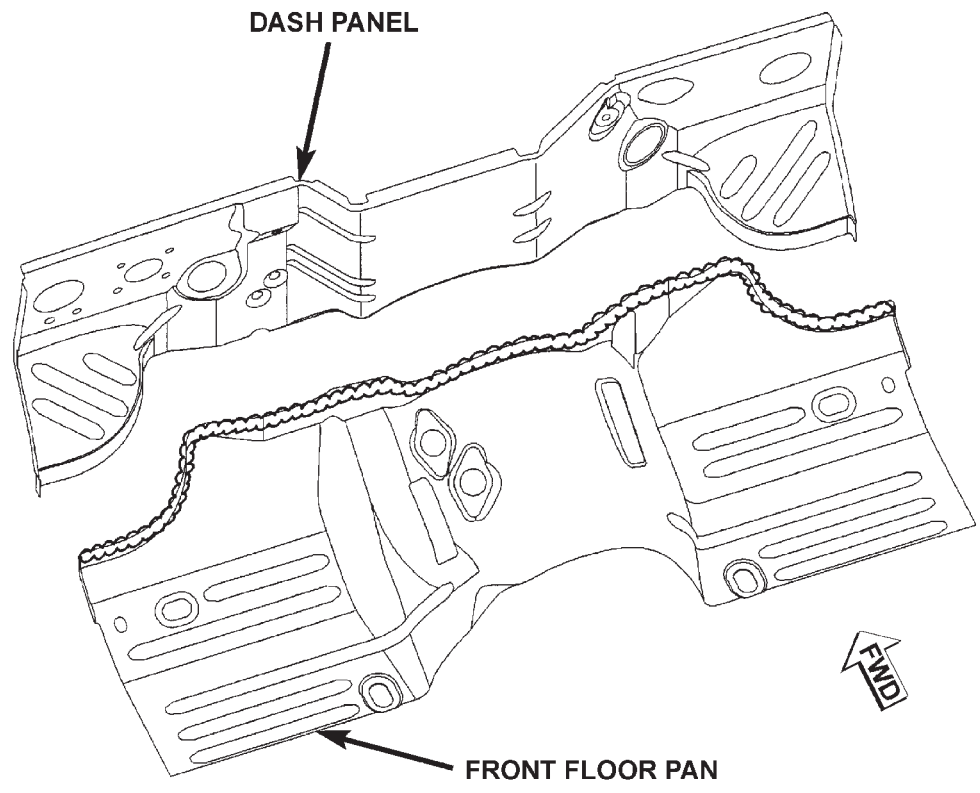

8066e98

SPECIFICATIONS (Continued)

PLENUM AND WINDSHIELD WIPER MOUNTING

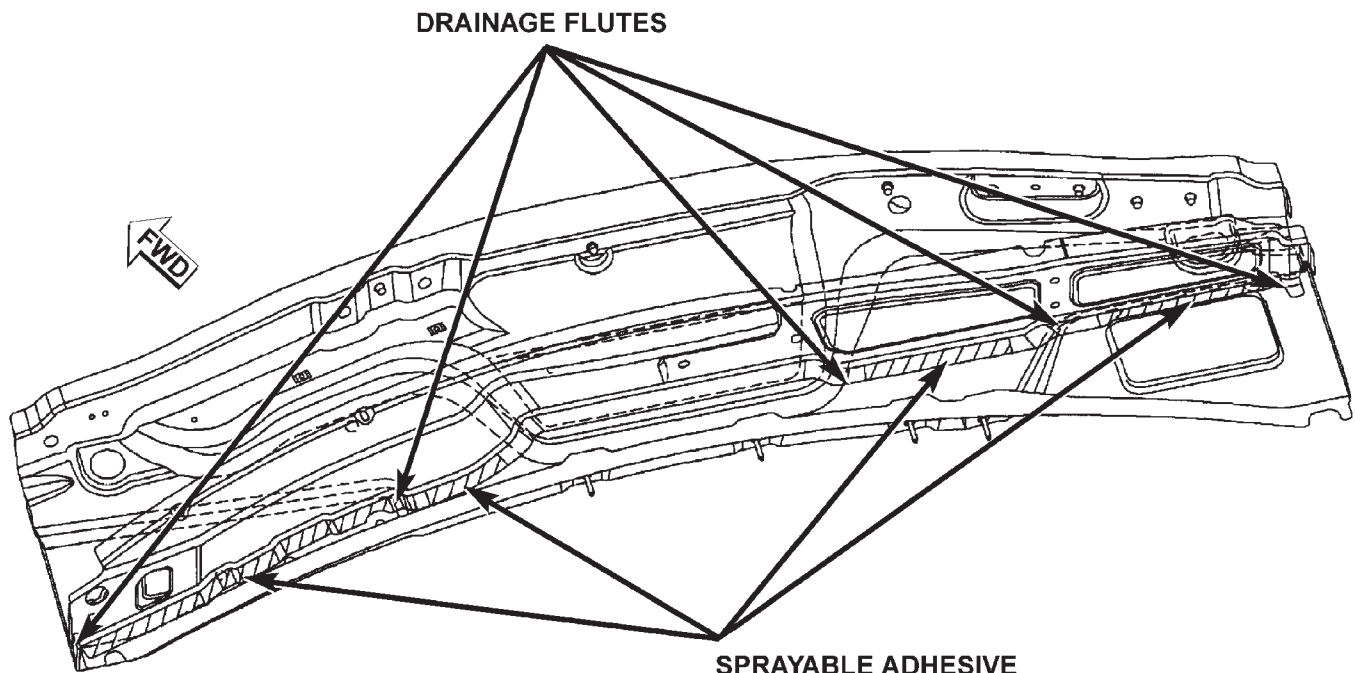

**SPRAYABLE ADHESIVE
900 MM X 25 MM X 2 MM
APPLY ON TOP OF SPOT WELDS.
AVOID ALL DRAINAGE FLUTES.**

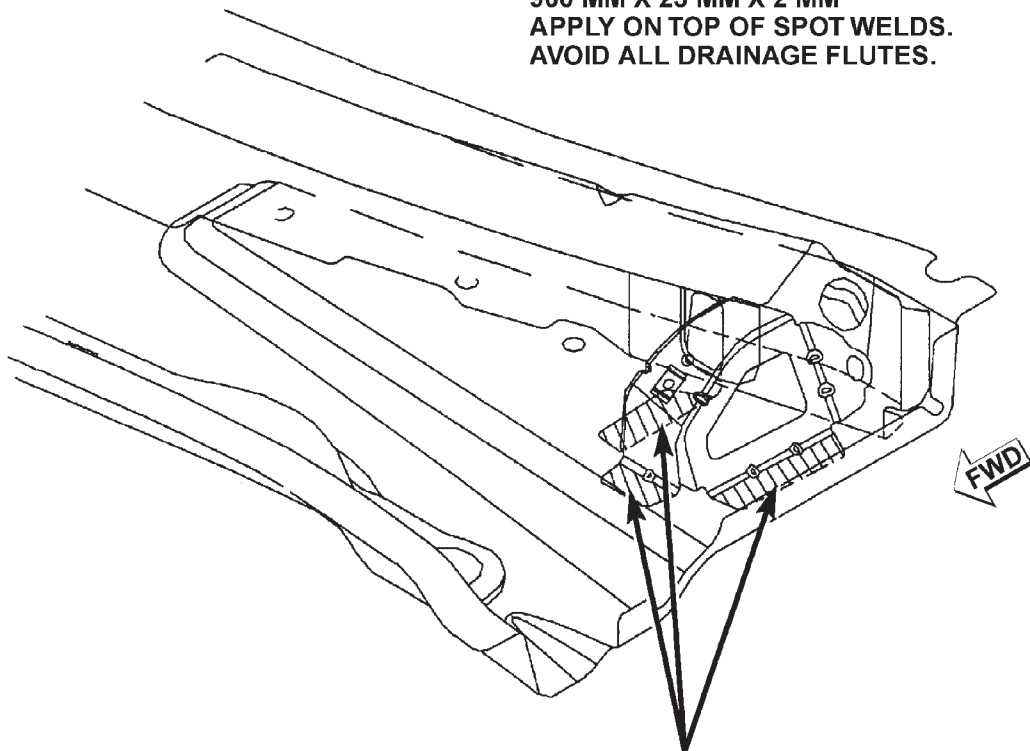

**SPRAYABLE ADHESIVE
200 MM X 25 MM X 2 MM
APPLY ON TOP OF SPOT WELDS
(LEFT SIDE ONLY)**

SPECIFICATIONS (Continued)

FRONT FLOOR PAN AND SILLS

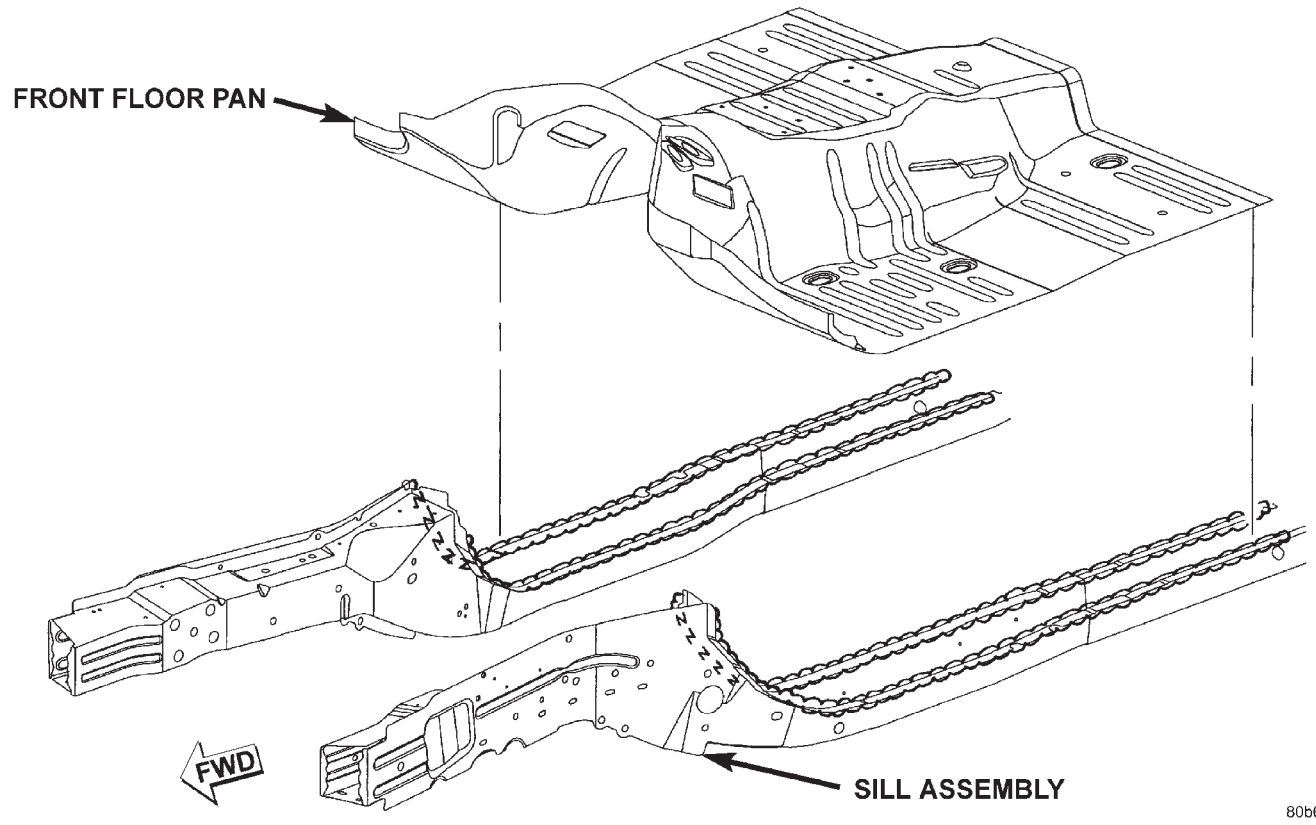

8066e99

SPECIFICATIONS (Continued)

FRONT AND CENTER FLOOR PAN

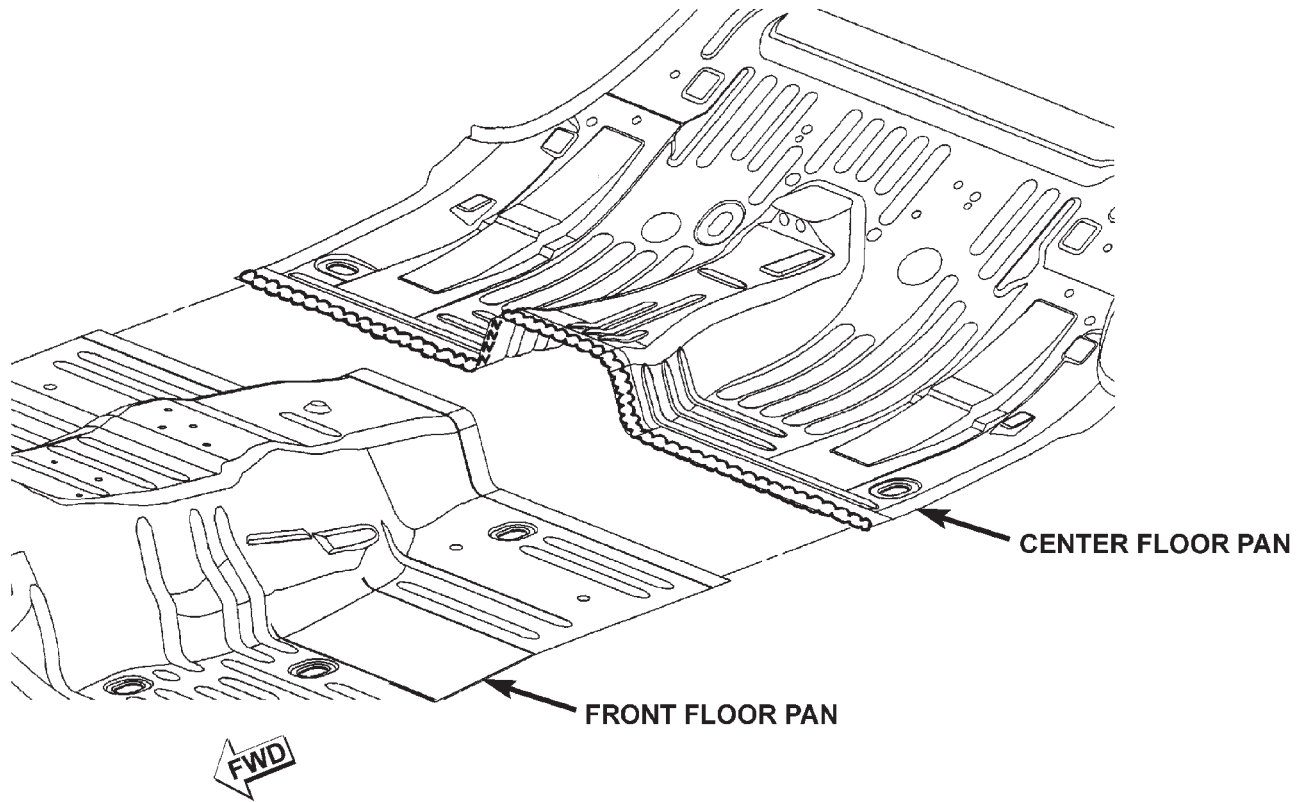

80b6fe9a

SPECIFICATIONS (Continued)

FRONT PAN AND INNER BODY SIDE APERTURE

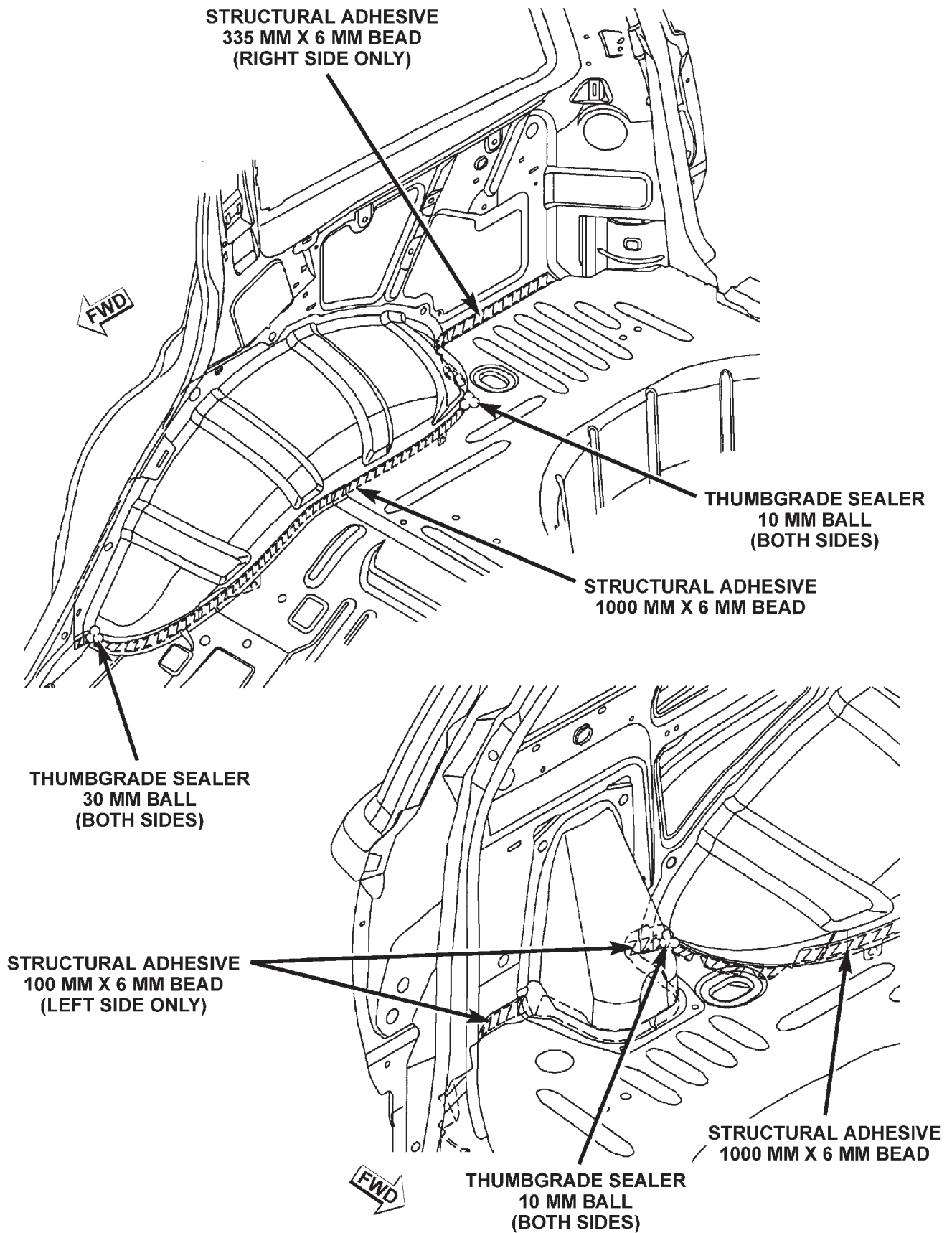

SPECIFICATIONS (Continued)

REAR SEAT CROSSMEMBER

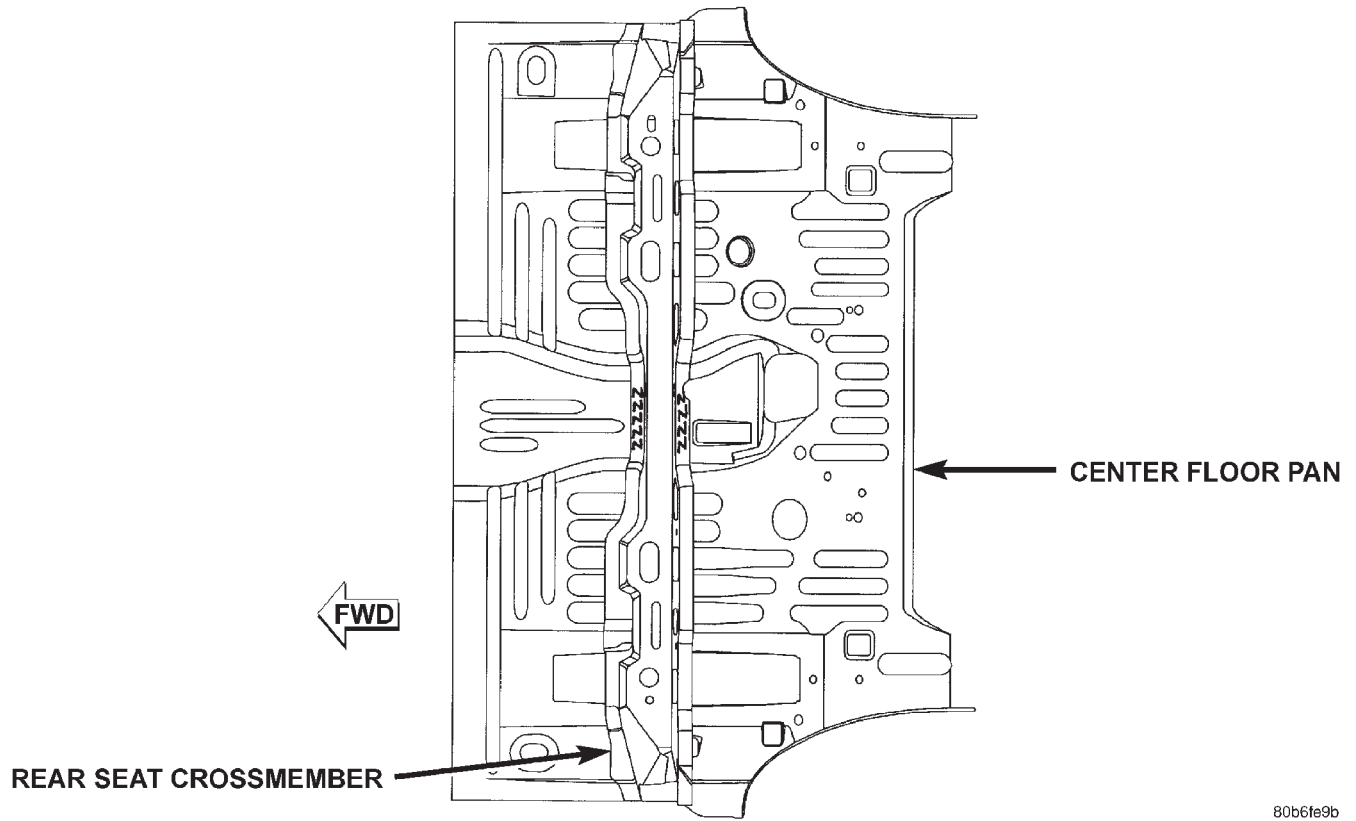

80b6fe9b

SPECIFICATIONS (Continued)

REAR INNER WHEELHOUSE

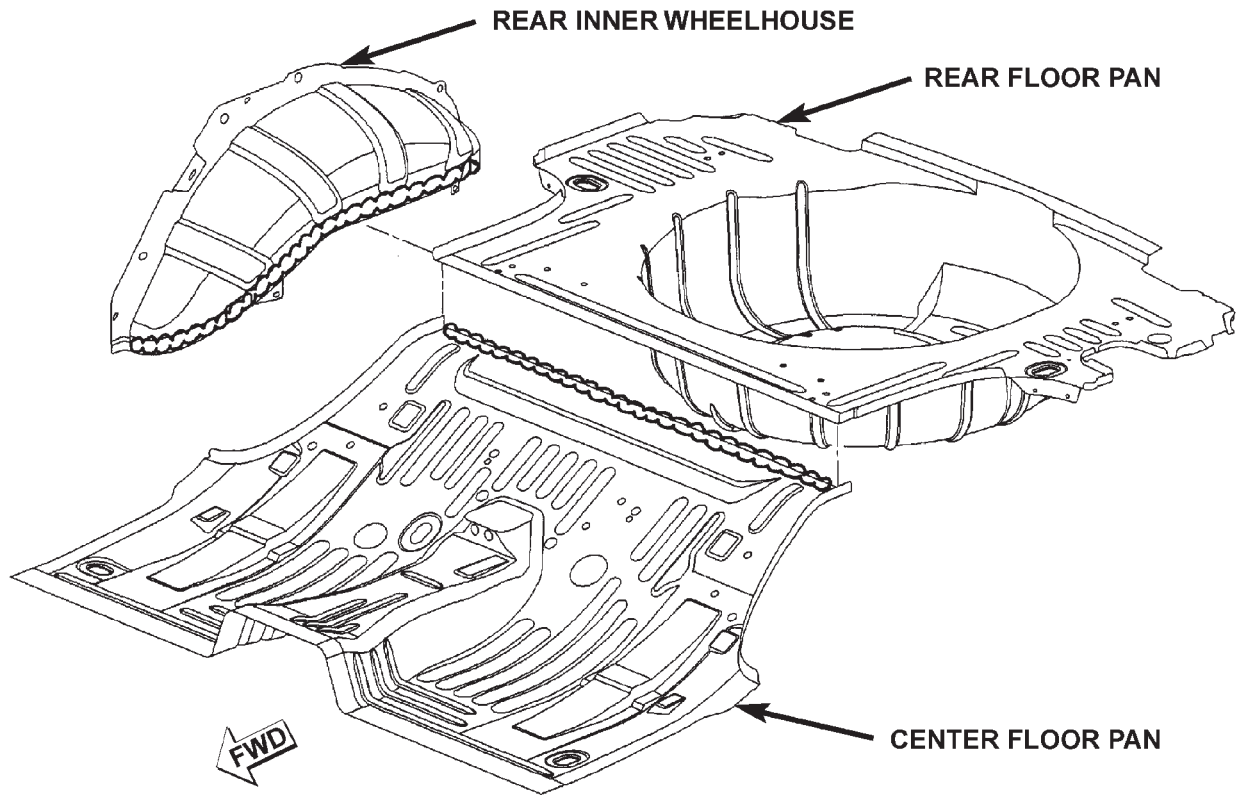

80b6fe9c

SPECIFICATIONS (Continued)

FLOOR PAN AND SILL ASSEMBLY

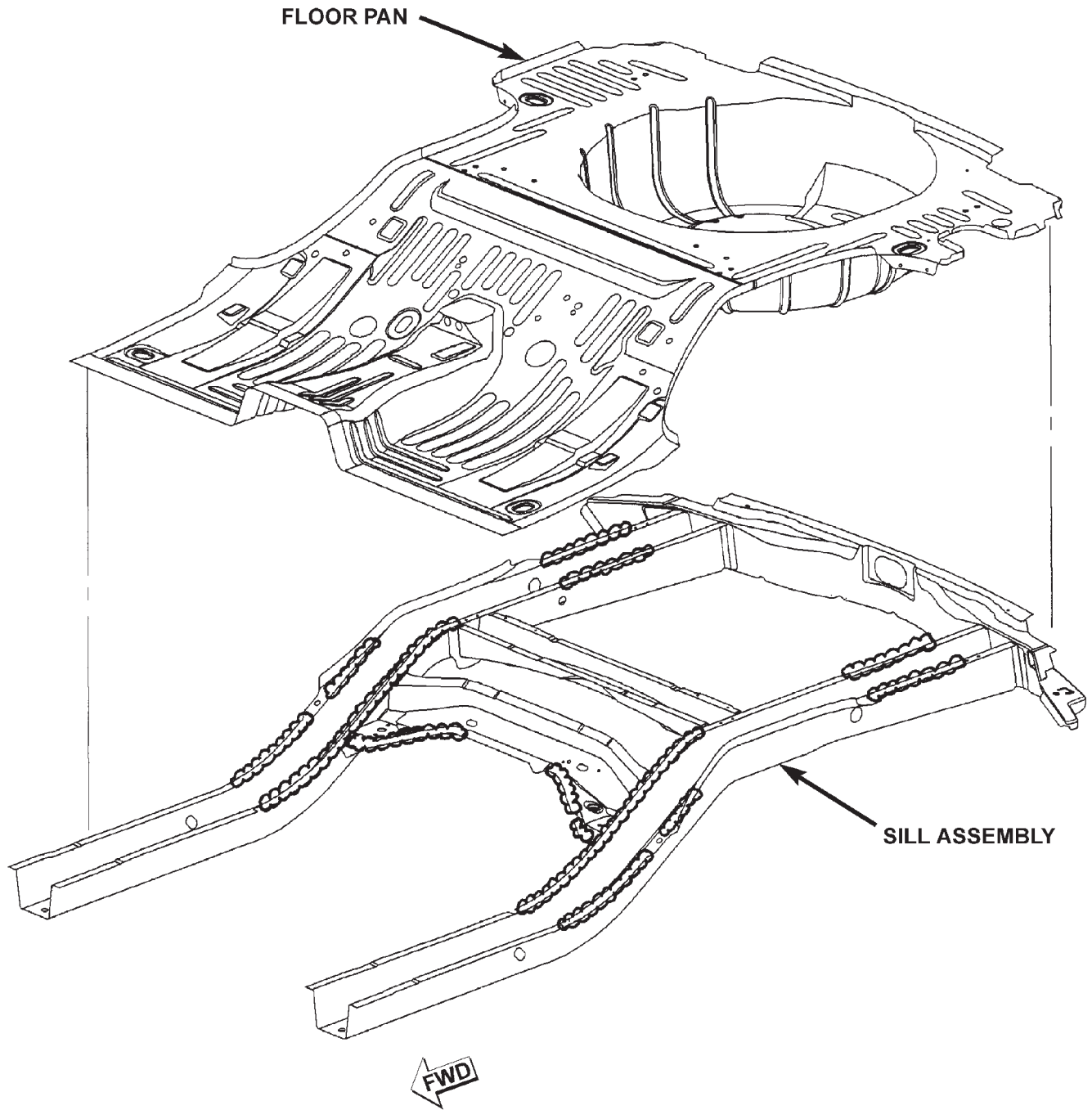

SPECIFICATIONS (Continued)

FLOOR PAN

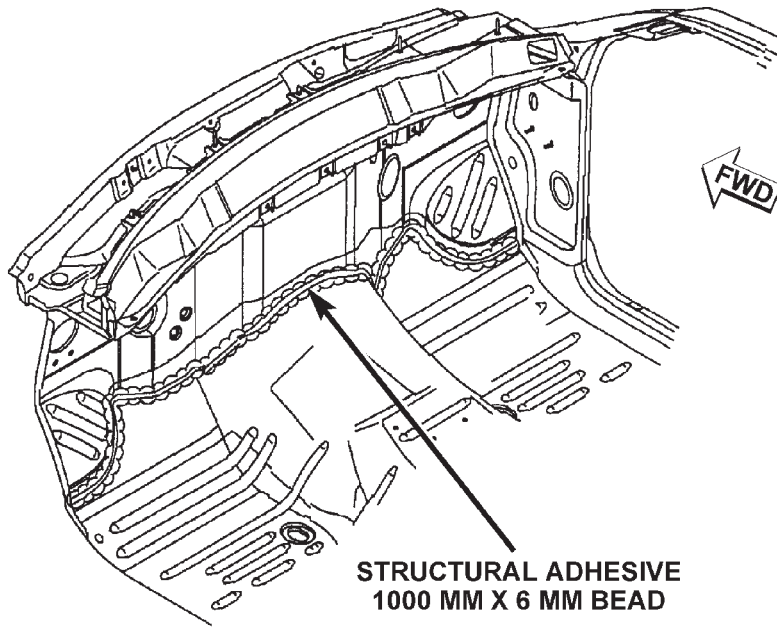

**STRUCTURAL ADHESIVE
1775 MM X 6 MM BEAD
MUST COVER TO EDGE OF PART**

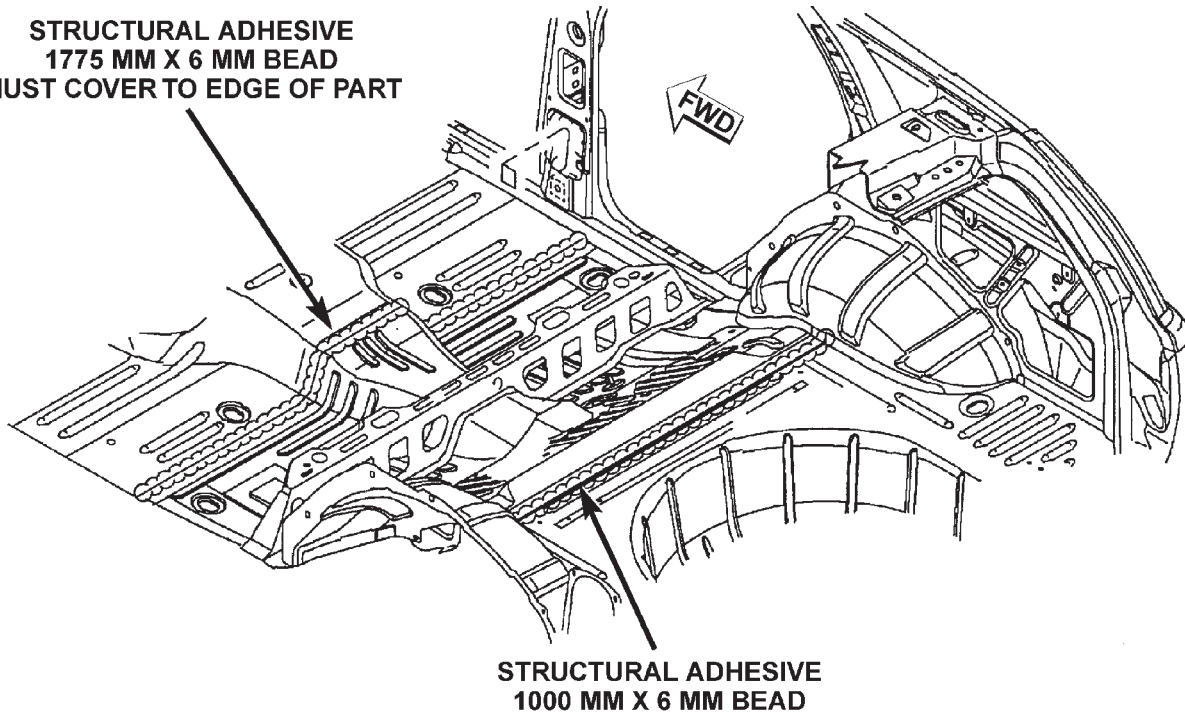

SPECIFICATIONS (Continued)

REAR INNER WHEELHOUSE AND REAR FLOOR PAN

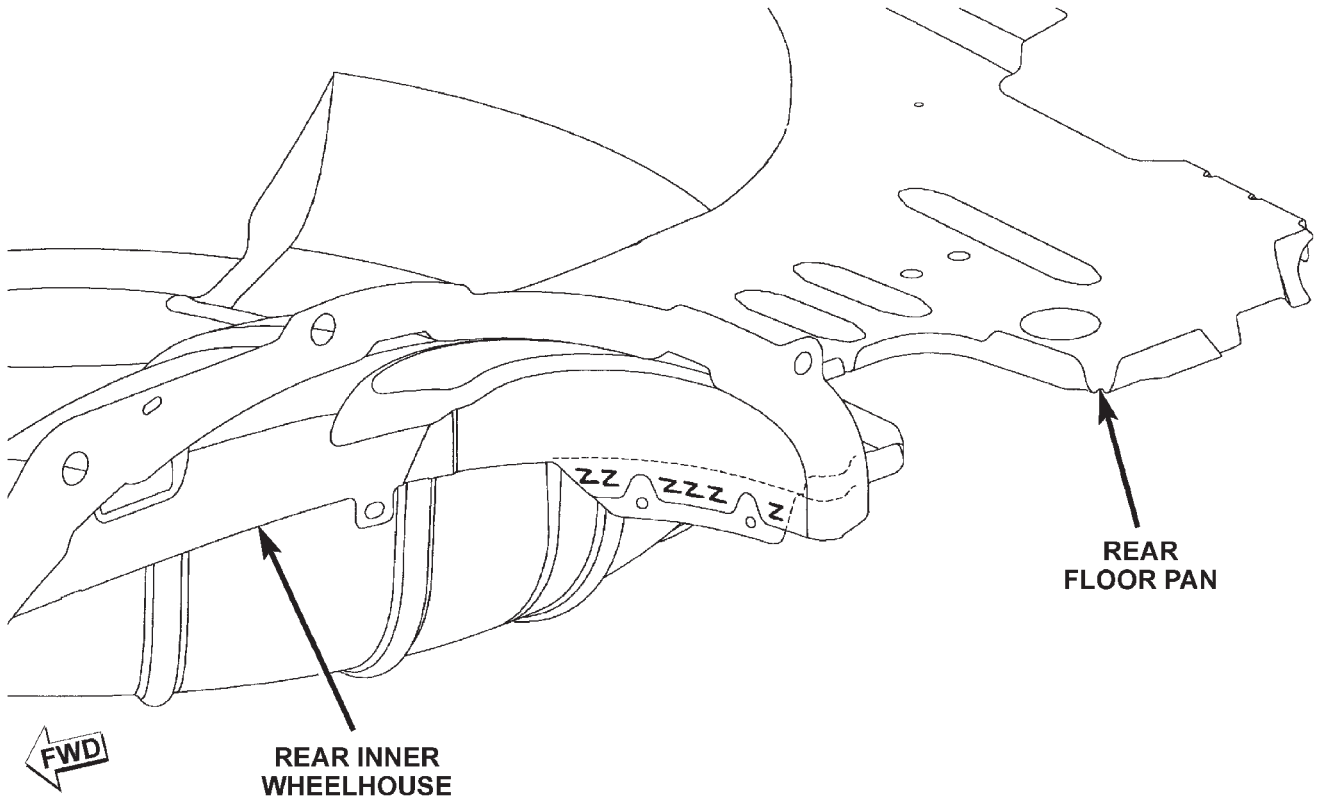

80b6fe9f

SPECIFICATIONS (Continued)

RIGHT INNER BODYSIDE APERTURE

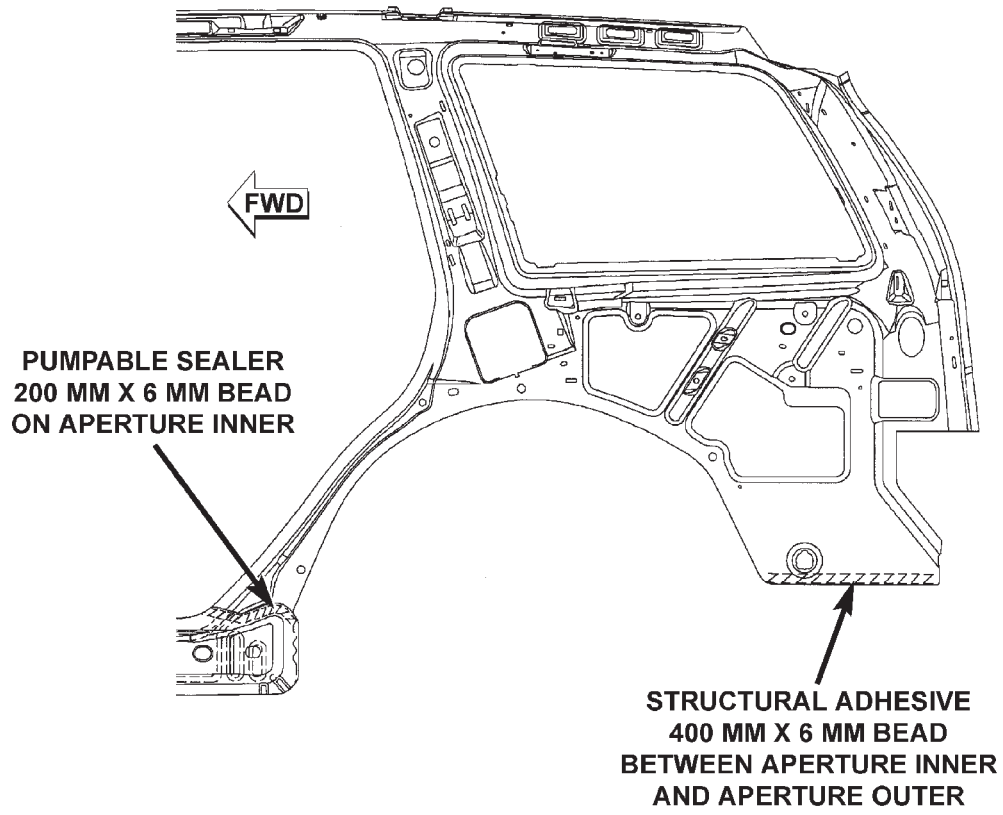

SPECIFICATIONS (Continued)

BODY SIDE INNER PANEL AND WHEELHOUSE

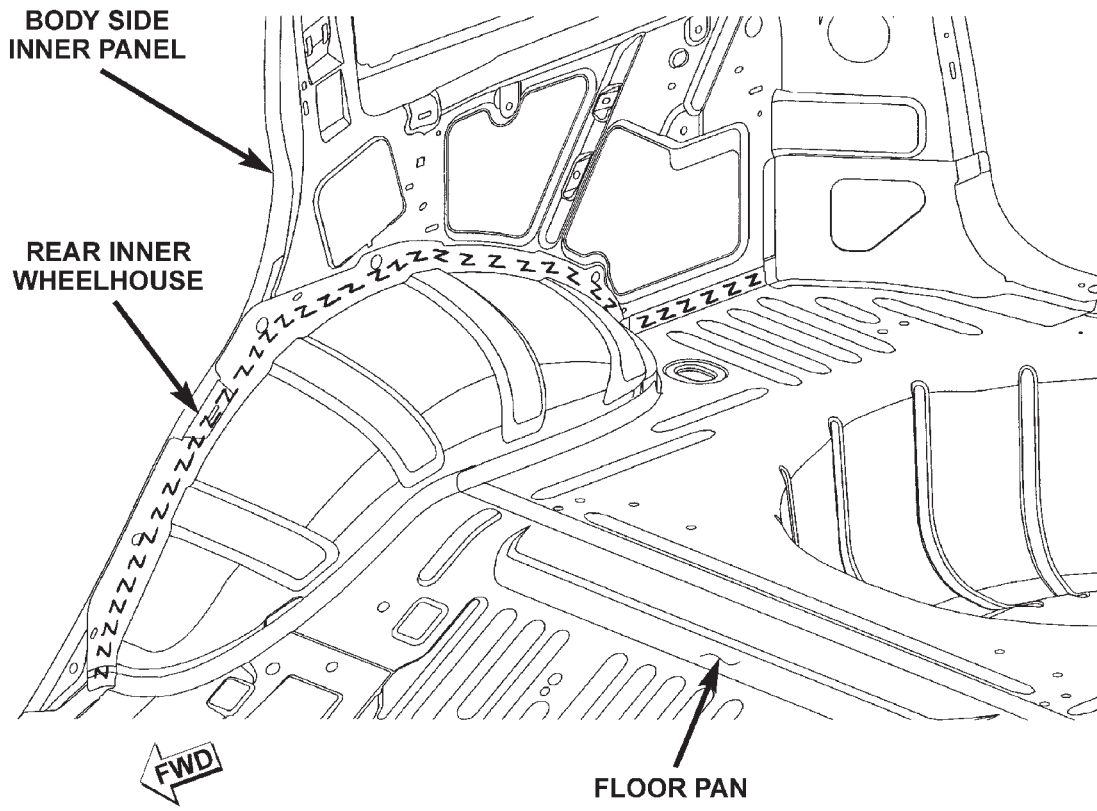

80b6fea0

SPECIFICATIONS (Continued)

BODY SIDE OUTER PANEL AND REAR
WHEELHOUSE OUTER PANEL

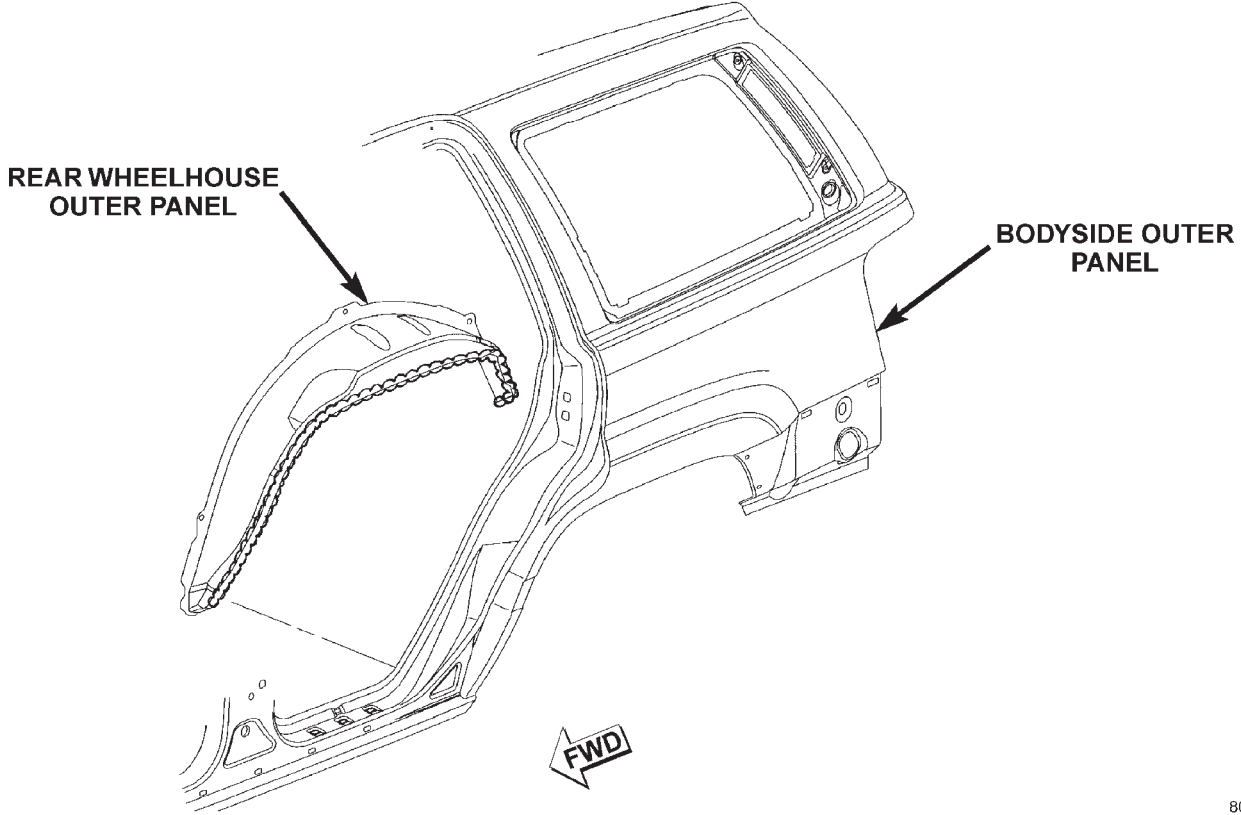

80b6fea1

SPECIFICATIONS (Continued)

D-PILLAR AND FUEL FILLER GUSSETS

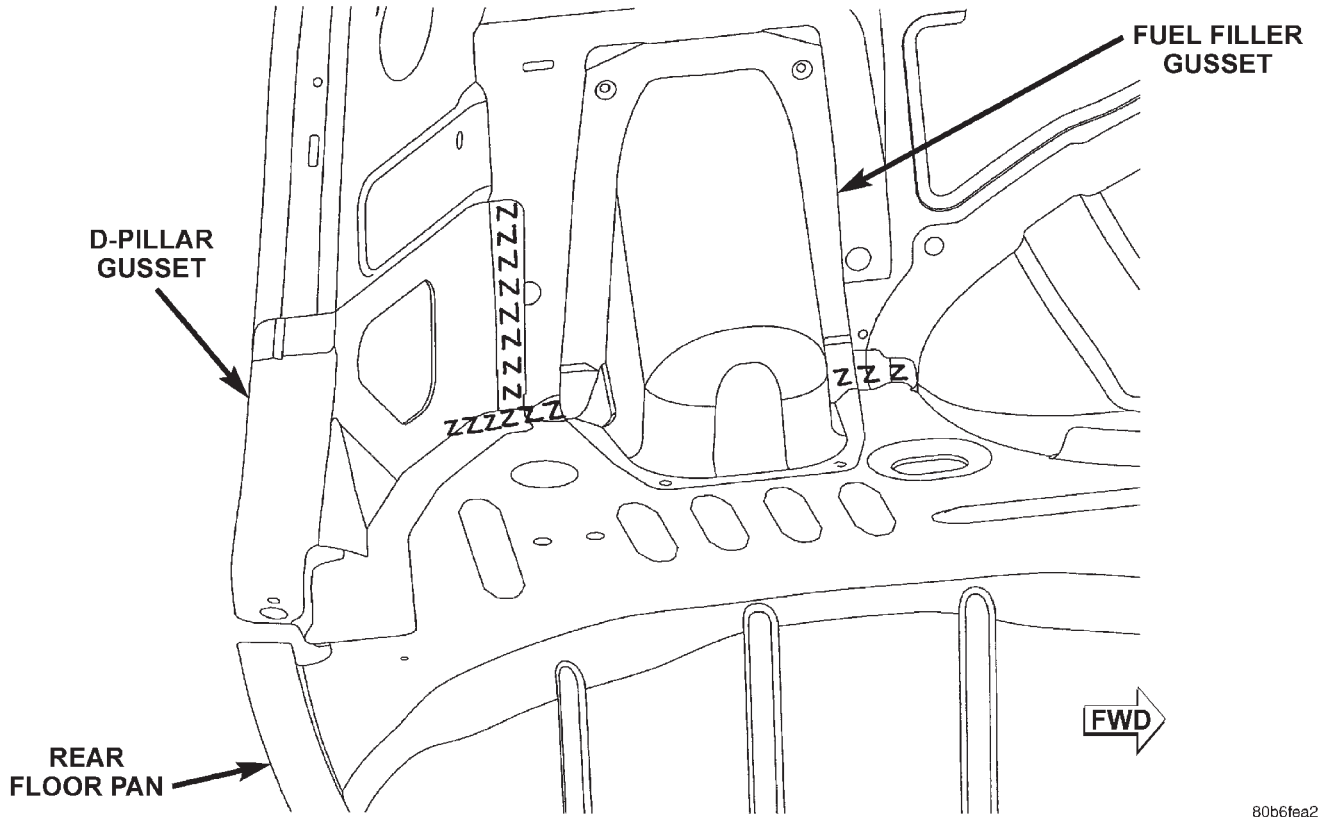

80b6fea2

SPECIFICATIONS (Continued)

LIFTGATE

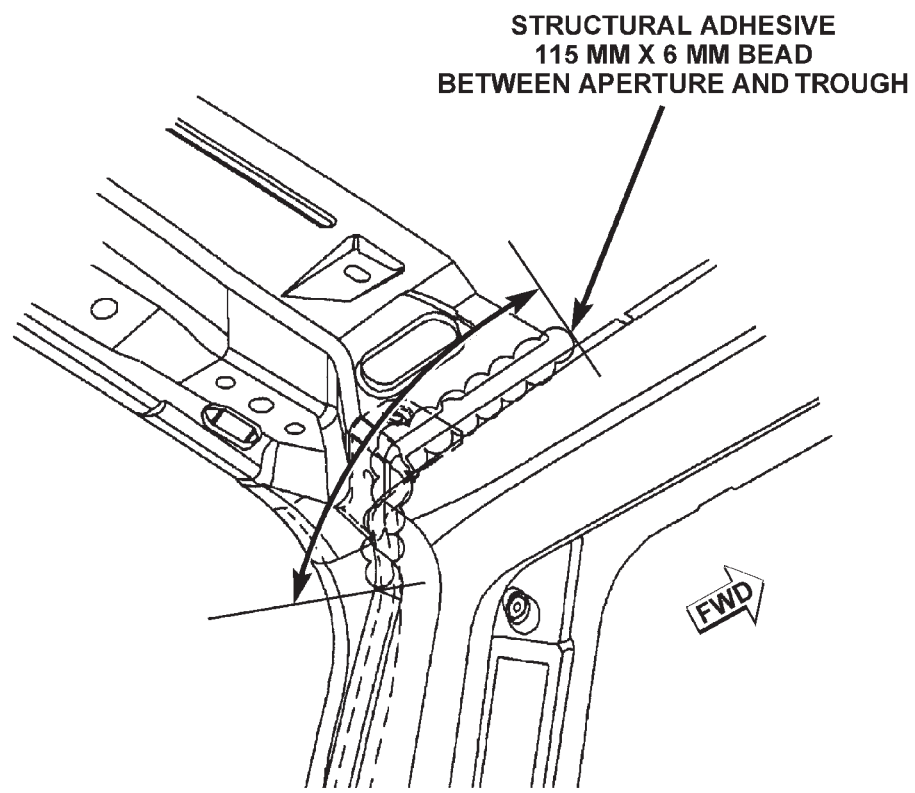
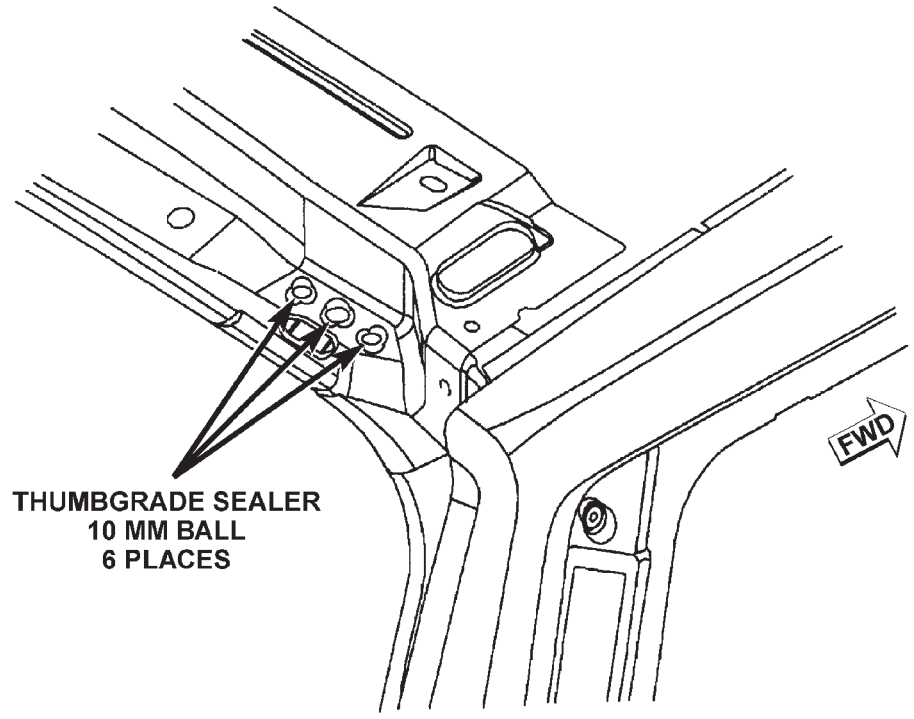

SPECIFICATIONS (Continued)

TAILLAMP MOUNTING PANEL

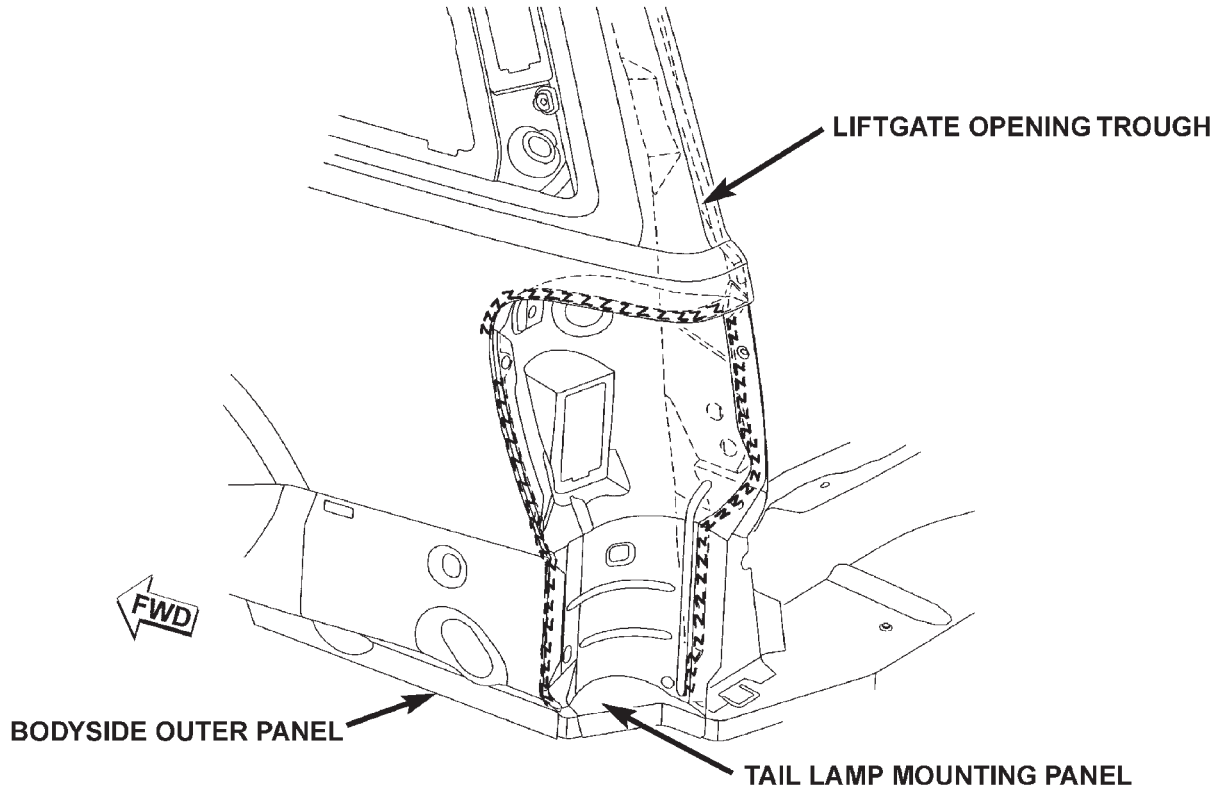

80b6fea3

SPECIFICATIONS (Continued)

TAILLAMP

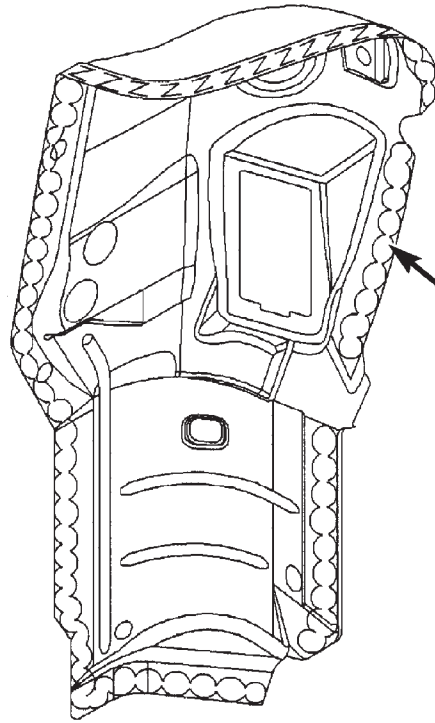

**STRUCTURAL ADHESIVE
800 MM X 6 MM BEAD
AROUND COMPLETE FLANGES
OF TAIL LAMP FLANGES**

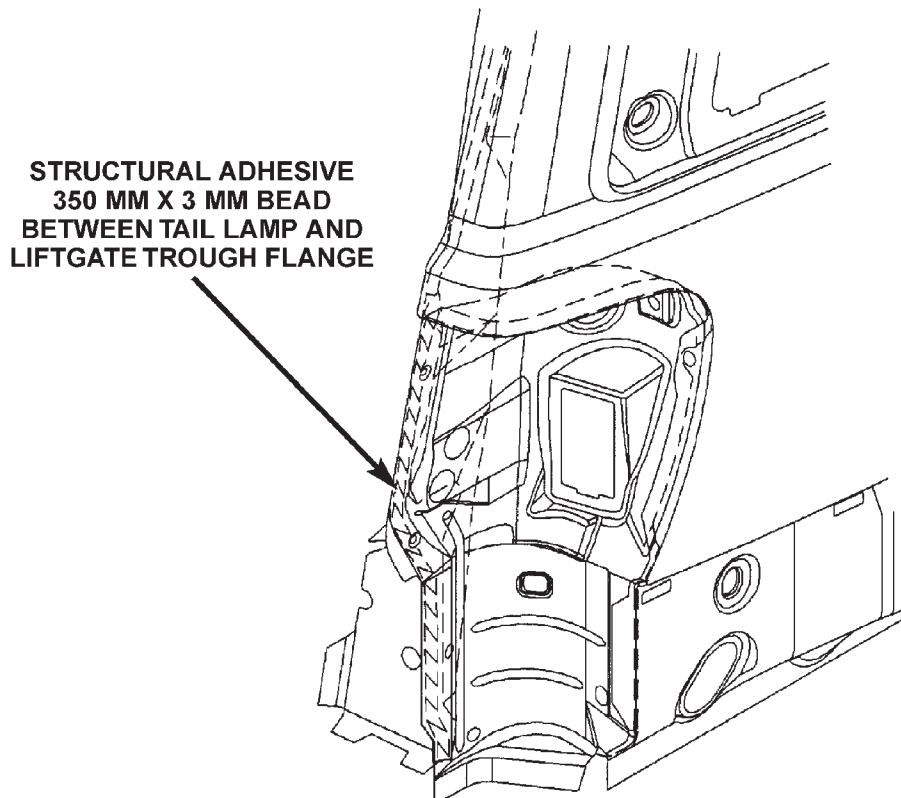

**STRUCTURAL ADHESIVE
350 MM X 3 MM BEAD
BETWEEN TAIL LAMP AND
LIFTGATE TROUGH FLANGE**

SPECIFICATIONS (Continued)

REAR INNER CROSSMEMBER

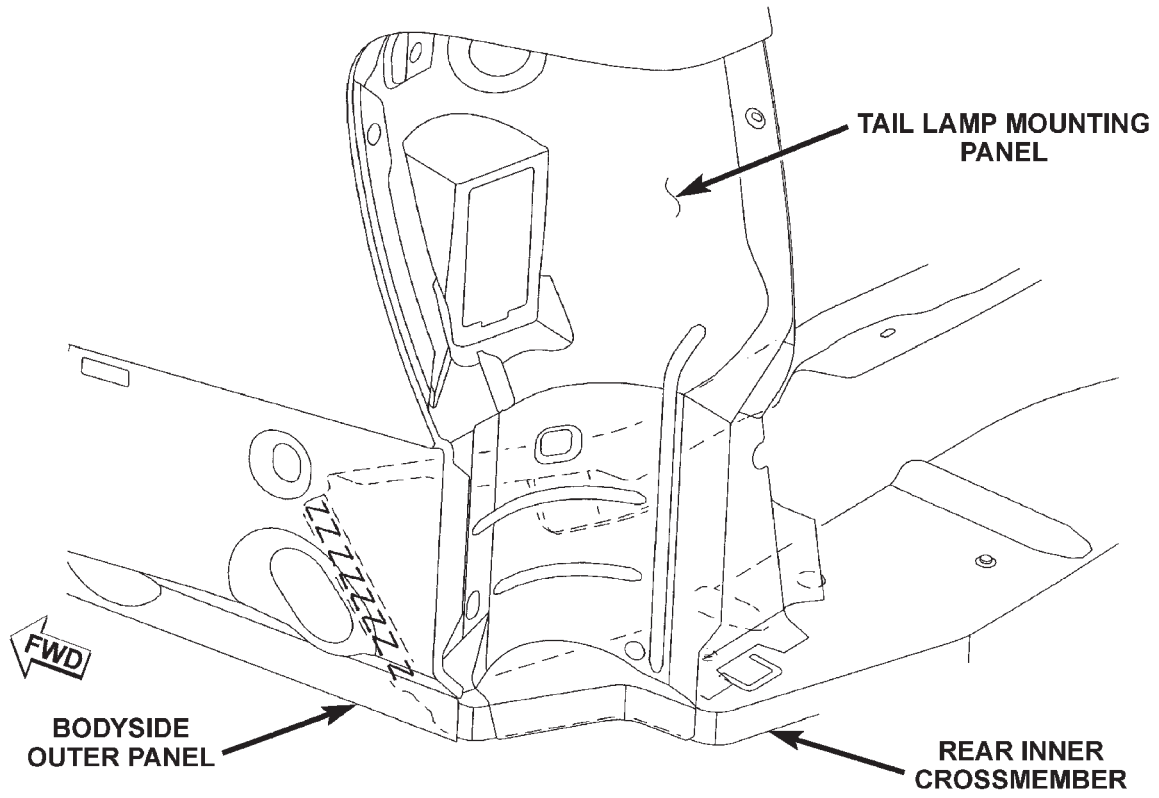

80b6fea4

SPECIFICATIONS (Continued)

ROOF BOWS

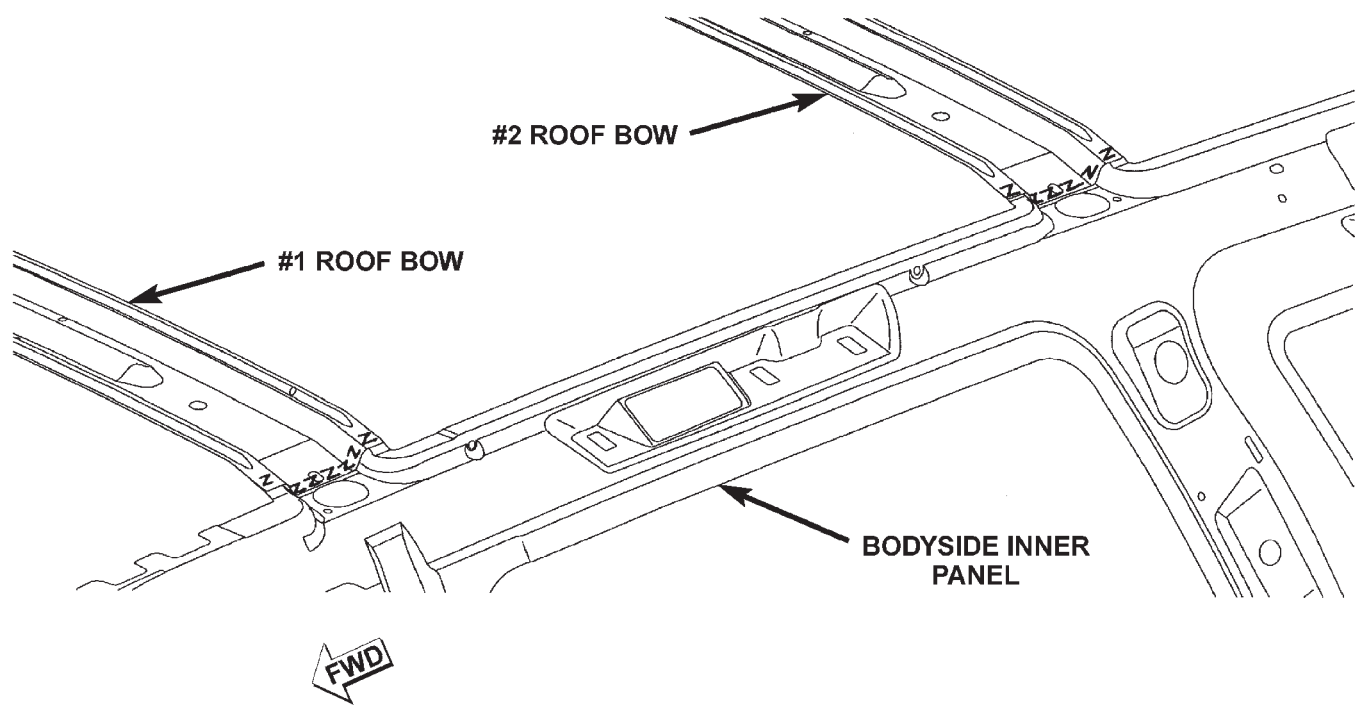

80b6fe95

SPECIFICATIONS (Continued)

REAR LOWER HEADER

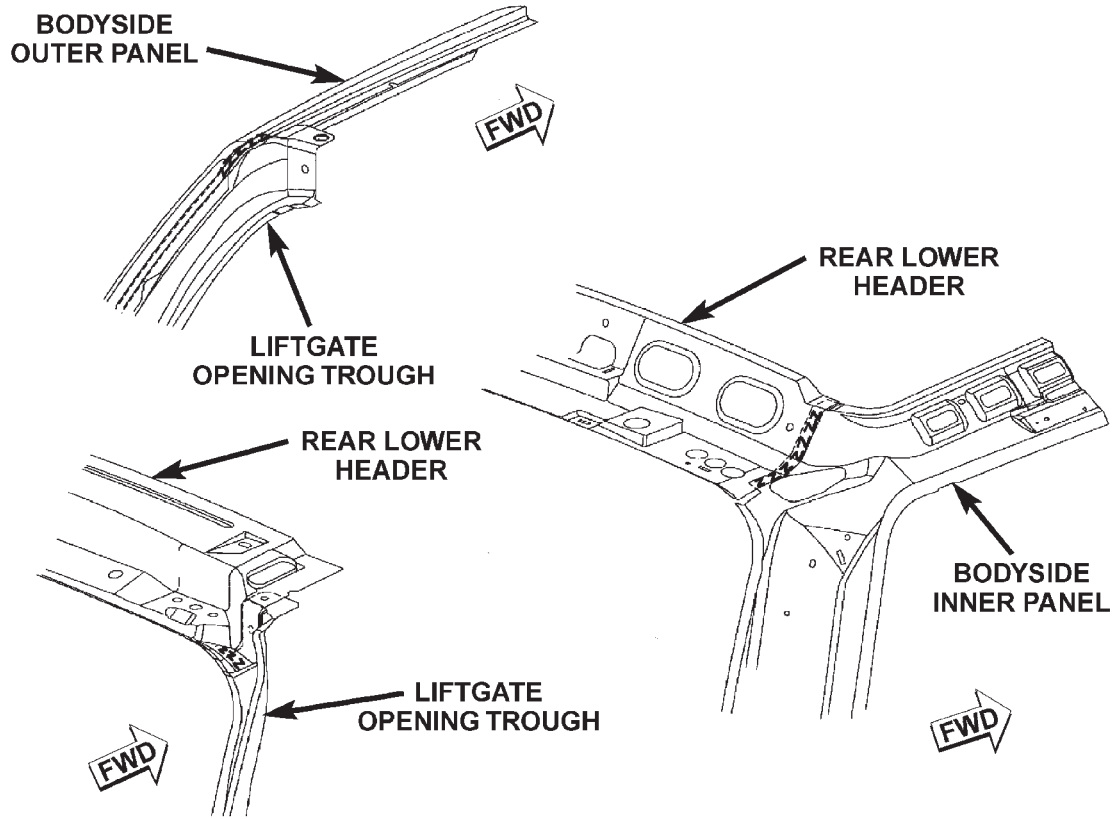

8066fe96

SPECIFICATIONS (Continued)

BODY GAP AND FLUSH MEASUREMENTS

WJ FRONT VIEW

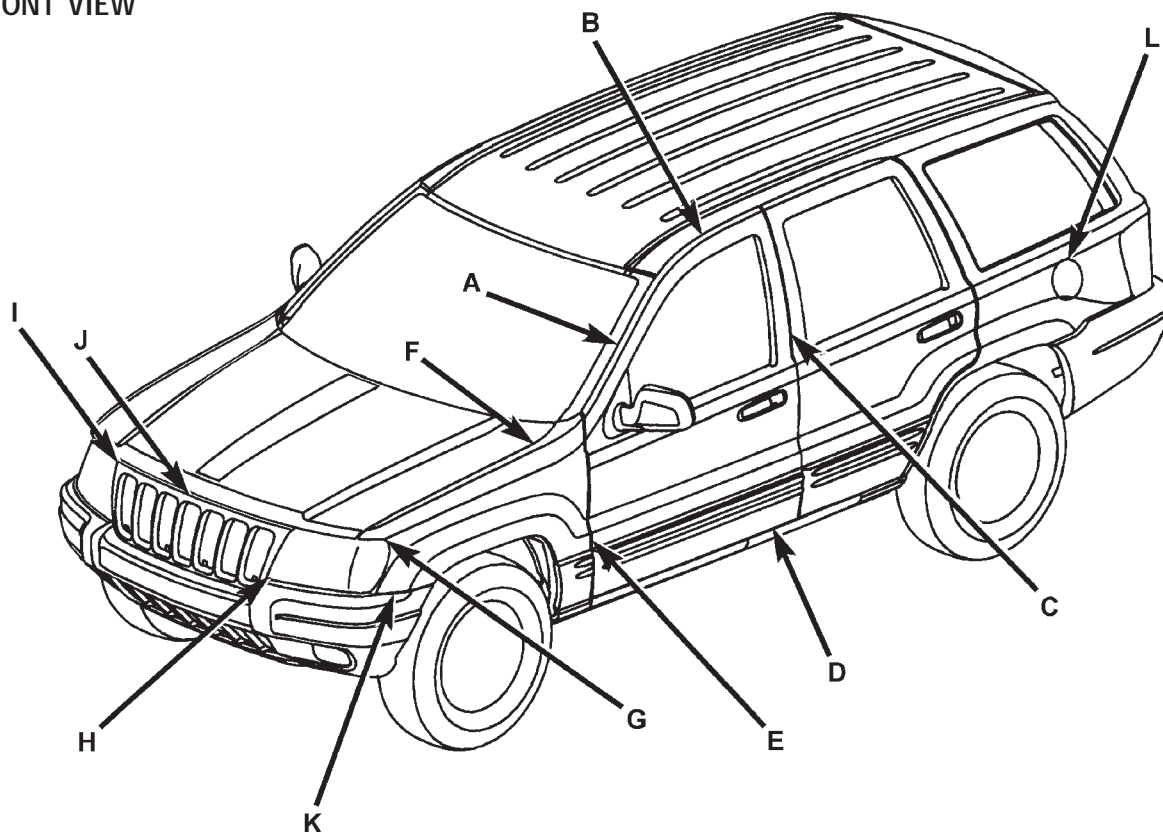

	LOCATION	GAP	FLUSH
A	Front Door to Windshield Pillar	N/A	3.0 +/- 1.0
B	Front Door Header to Aperture	6.0 +/- 1.0	1.0 +/- 1.5
C	Front Door to Rear Door	5.0 +/- 1.0	0.0 +/- 1.0
D	Front Door to Aperture at Sill	7.0 +/- 1.5	N/A
E	Front Door to Fender	5.0 +/- 1.0	0.5 +/- 1.0
F	Hood to Fender	5.0 +/- 1.0	0.0 +/- 1.0
G	Headlamp to Fender	5.0 +/- 2.0	3.0 +/- 2.0
H	Headlamp to Grille	5.5 +/- 2.0	0.0 +/- 2.0
I	Grille to Headlamp	N/A	0.0 +/- 1.0
J	Grille to Hood	10.0 +/- 2.0	0.8 +/- 2.0
K	Front Fascia to Fender	Net + 1.0 - 0.0	3.0 +/- 3.0
L	Fuel Filler Door to Bodyside	3.0 +/- 0.75	0.5 +/- 0.75

NOTE: ALL MEASUREMENTS ARE IN MM.

SPECIFICATIONS (Continued)

WJ REAR VIEW

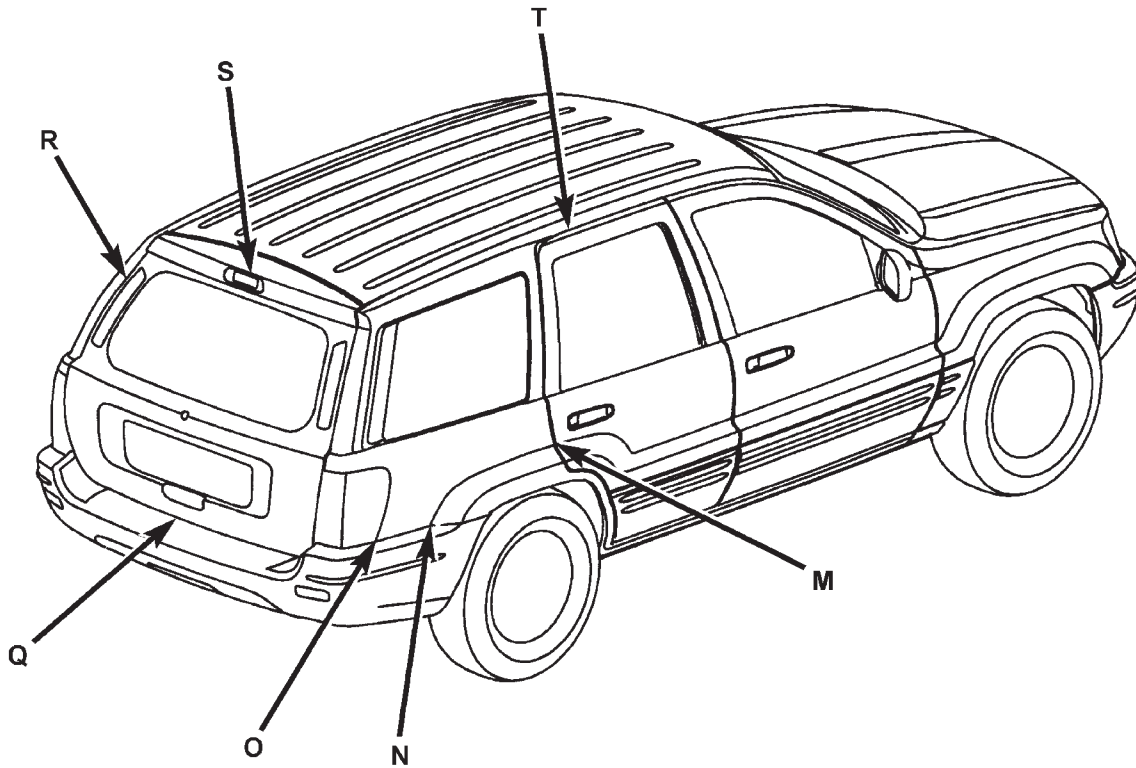

	LOCATION	GAP	FLUSH
M	Rear Door to Quarter Panel	5.0 +/- 1.0	0.0 +/- 1.0
N	Aperture to Rear Fascia	Net to 1.0	3.0 +/- 2.0
O	Taillamp to Quarter Panel	2.0 +/- 1.0	3.0 +/- 1.5
P	Taillamp to Liftgate	5.0 +/- 1.5	3.0 +/- 1.5
Q	Liftgate to Fascia	10.0 +/- 3.0	N/A
R	Liftgate to Aperture	5.0 +/- 1.5	1.0 +/- 1.0
S	Liftgate to Roof	11.0 +/- 1.5	1.0 +/- 1.0
T	Rear Door Header to Aperture	6.0 +/- 1.0	1.0 +/- 1.5

NOTE: ALL MEASUREMENTS ARE IN MM.

SPECIFICATIONS (Continued)

BODY OPENING DIMENSIONS

WINDSHIELD AND FRONT DOOR OPENING

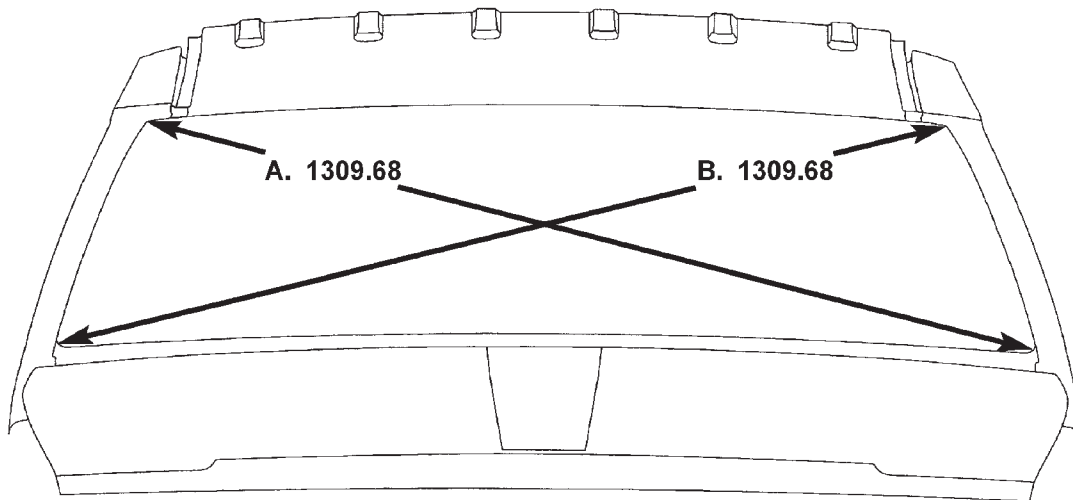

ALL MEASUREMENTS IN MILLIMETERS

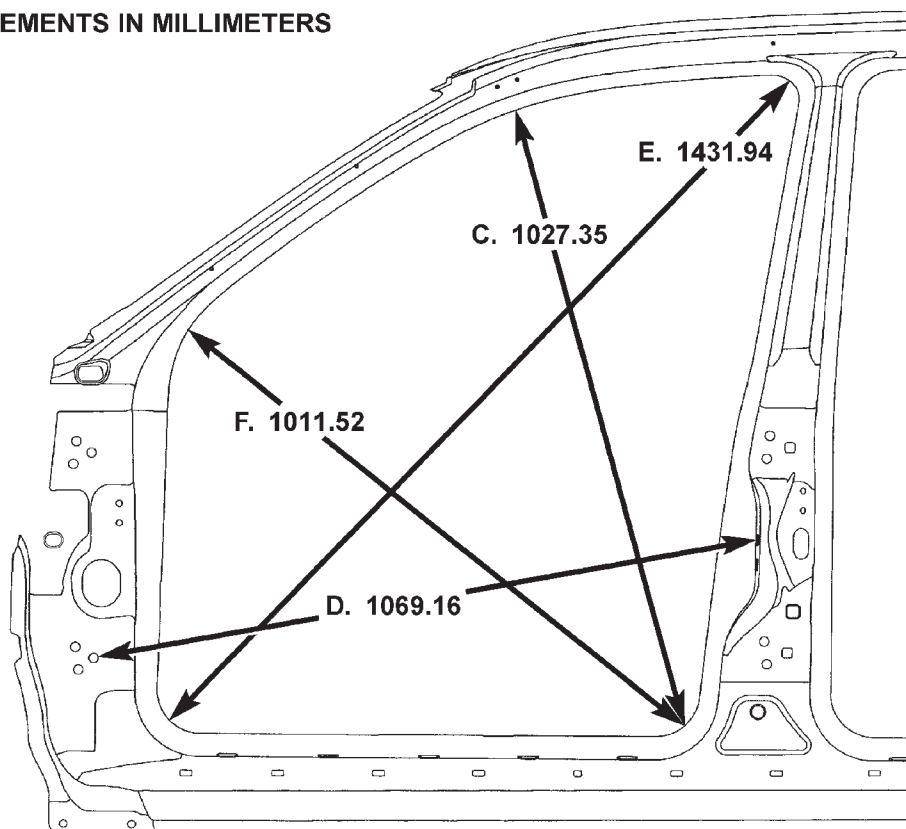

- A. & B.** Center of radius at bottom to center of radius at top.
- C.** Center of front door lower rear corner radius to center of A-pillar radius.
- D.** Center of door hinge mount to center of door striker mount.
- E.** Center of radius at bottom front to center of radius at top rear.
- F.** Center of radius at bottom rear to center of radius at lower A-pillar.

SPECIFICATIONS (Continued)

REAR DOOR AND QUARTER GLASS OPENING

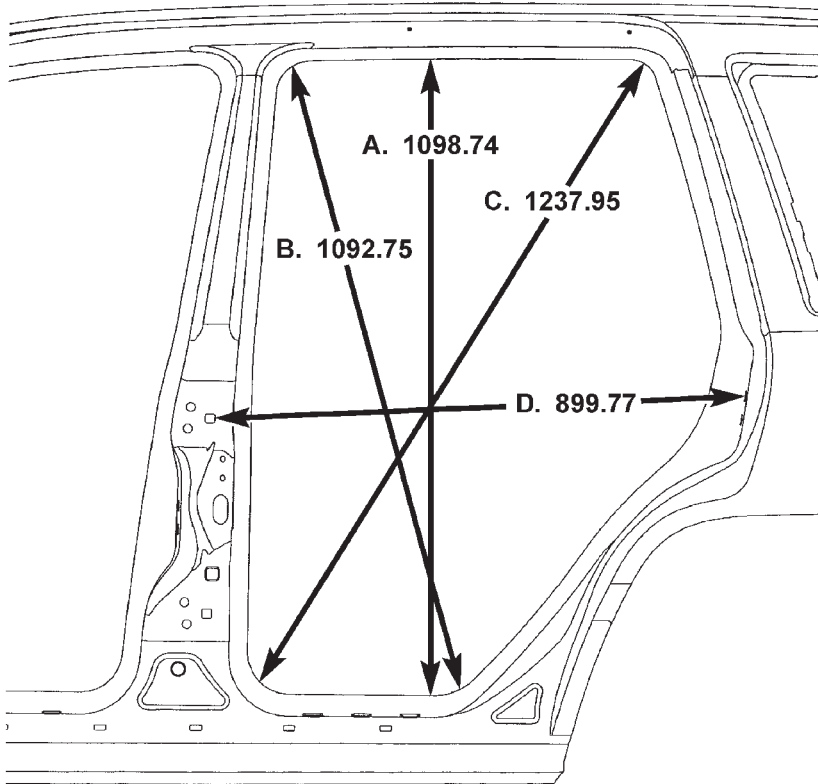

- A.** Quarter panel to front outer body side upper and lower seam.
- B.** Center of front upper door radius to center of rear lower door radius.
- C.** Center of front lower door radius to center of rear upper door radius.
- D.** Rear door hinge mount to rear door striker mount.

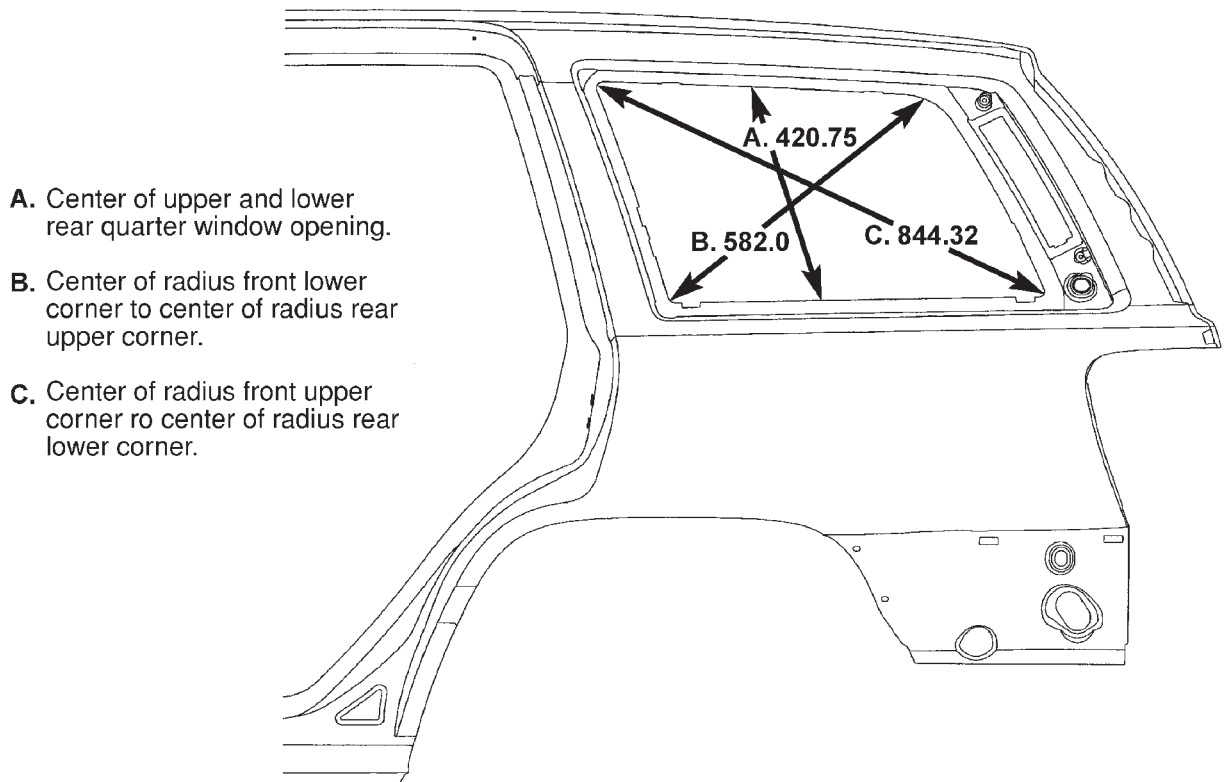

- A.** Center of upper and lower rear quarter window opening.
- B.** Center of radius front lower corner to center of radius rear upper corner.
- C.** Center of radius front upper corner to center of radius rear lower corner.

ALL MEASUREMENTS IN MILLIMETERS

SPECIFICATIONS (Continued)

LIFTGATE OPENING AND ENGINE COMPARTMENT

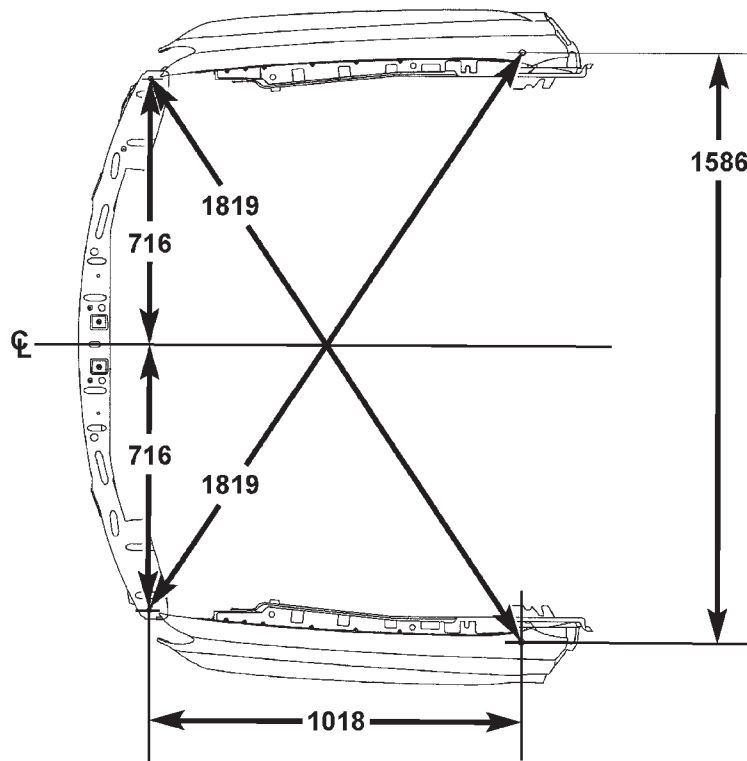
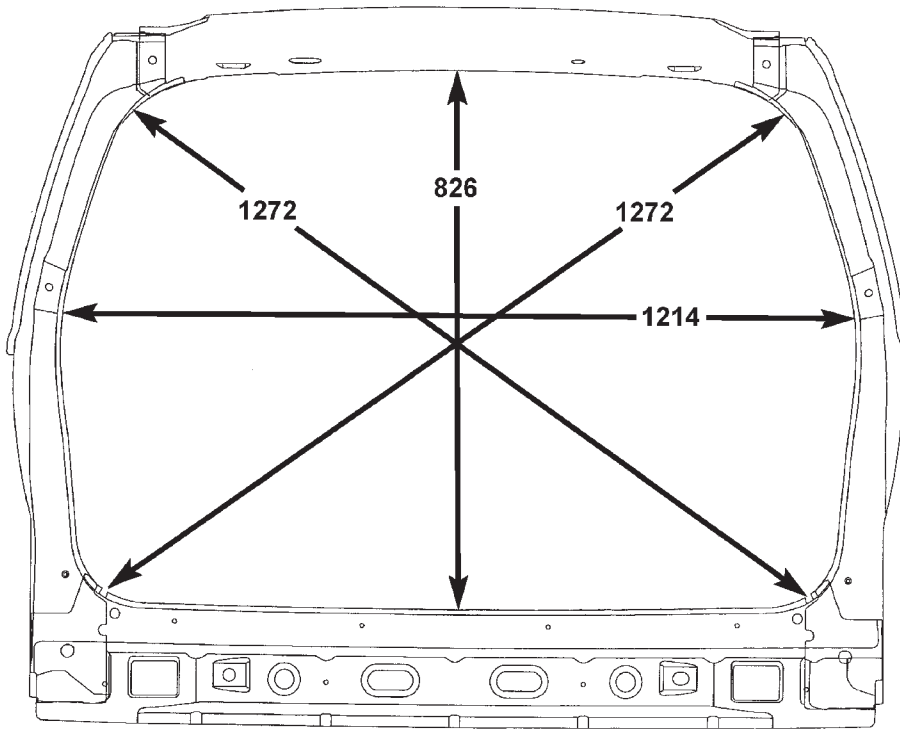

ALL MEASUREMENTS IN MILLIMETERS

SPECIFICATIONS (Continued)

TORQUE SPECIFICATIONS

BODY COMPONENTS

DESCRIPTION	TORQUE
Sunroof module to roof panel. . .	11N·m (97 in. lbs.).
Front bucket seat to floor pan bolts.	40N·m (30 ft. lbs.).
Front bucket seat to floor pan front bolts.	40N·m (30 ft. lbs.).
Bucket seat track adjuster nuts to seat cushion frame.	28N·m (20 ft. lbs.).
Bucket seat recliner to seat back frame bolts.	28N·m (20 ft. lbs.).
Bucket seat back frame recliner bolts to seat cushion frame.	28N·m (20 ft. lbs.).
Rear seat cushion latch base panel screws.	8 N·m (75 in. lbs.).
Rear seat cushion to floor pan bolts.	11 N·m (8 ft. lbs.).
Rear seat back left side support bracket to center pivot bracket.	28 N·m (20 ft. lbs.).
Rear seat back right side support bracket.	28N·m (20 ft. lbs.).
Rear seat back latch/hinge to seat back frame.	28N·m (20 ft.lbs.).
Hood latch to radiator crossmember.	11N·m (8 ft.lbs.).
Front door hinge bolts.	35N·m (26 ft. lbs.).
Front door latch to door screws. . .	10N·m (7 ft. lbs.).
Front door striker to B pillar. . . .	28N·m (20 ft. lbs.).
Rear door latch to door screws.	10N·m (95 in. lbs.).
Rear door striker to C pillar screws.	28N·m (250 in. lbs.).
Rear view mirror set screw.	1N·m (15 in. lbs.).
Lift gate latch striker to D pillar nuts.	10N·m (7 ft. lbs.).
Door latch adjustment screw.	3N·m (30 in. lbs.).

SPECIAL TOOLS

BODY

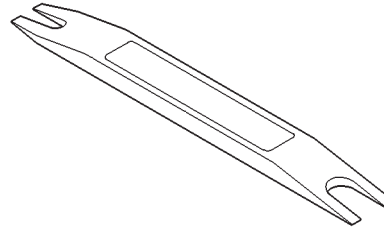

Remover, Moldings C-4829

