

ENGINE

CONTENTS

	page	page
GENERAL INFORMATION		
ENGINE IDENTIFICATION	1	
HYDRAULIC TAPPETS	1	
DIAGNOSIS AND TESTING		
SERVICE DIAGNOSIS—DIESEL—		
MECHANICAL	9	
SERVICE DIAGNOSIS—DIESEL—		
PERFORMANCE	3	
TAPPET NOISE	12	
SERVICE PROCEDURES		
VALVE SERVICE	12	
REMOVAL AND INSTALLATION		
3.1L TURBO DIESEL ENGINE	14	
CAMSHAFT	41	
CAMSHAFT BEARINGS	42	
CRANKSHAFT AND MAIN BEARINGS	51	
CYLINDER HEAD COVER	28	
CYLINDER WALL LINER ASSEMBLY	49	
ENGINE CYLINDER HEAD	32	
ENGINE OIL FILTER	45	
EXHAUST / INTAKE MANIFOLD	24	
HYDRAULIC TAPPETS	29	
INTERNAL VACUUM PUMP	43	
OIL FILTER ADAPTER AND OIL COOLER	45	
OIL PAN	43	
OIL PUMP	43	
OIL PUMP PRESSURE RELIEF VALVE	44	
PISTONS AND CONNECTING ROD		
ASSEMBLY	46	
ROCKER ARMS AND PUSH RODS	30	
TIMING GEAR COVER	39	
TIMING GEAR COVER OIL SEAL	39	
VALVE SPRINGS	31	
VIBRATION DAMPER	38	
DISASSEMBLY AND ASSEMBLY		
HYDRAULIC TAPPETS	54	
CLEANING AND INSPECTION		
CYLINDER HEAD	54	
CYLINDER WALL LINER ASSEMBLY	56	
OIL PUMP	57	
PISTONS AND CONNECTING ROD		
ASSEMBLY	55	
ROCKER ARMS AND PUSH RODS	55	
SPECIFICATIONS		
ENGINE SPECIFICATIONS	58	
TORQUE SPECIFICATIONS	60	
SPECIAL TOOLS		
SPECIAL TOOLS	61	

GENERAL INFORMATION

ENGINE IDENTIFICATION

The engine model code and serial number are stamped on the left side of the engine block, just below the oil dipstick tube (Fig. 1). The model code for the 3.1L is 73B followed by a four digit serial number.

HYDRAULIC TAPPETS

Before disassembling any part of the engine to correct tappet noise, check the oil pressure. If vehicle has no oil pressure gauge, install a reliable gauge at the pressure sending unit. The pressure should be between 4 bars (50 psi) at 3000 RPM.

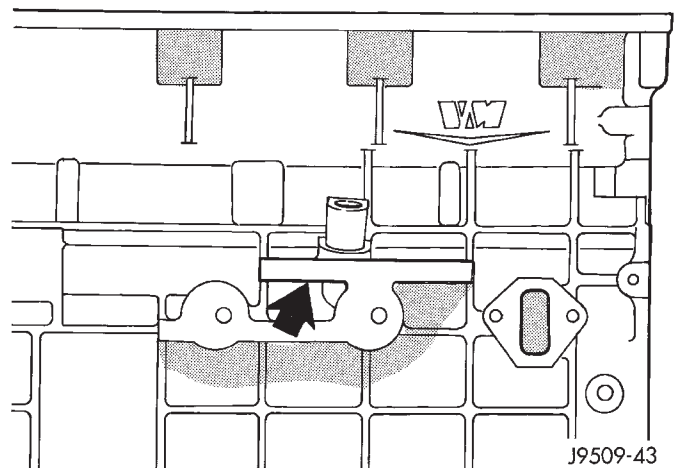

Fig. 1 Engine Code Location

GENERAL INFORMATION (Continued)

Displacement.....	3.1L (3125cc)
Bore.....	92.00 mm
Stroke.....	94.00 mm
Compression Ratio.....	20.95:1
Vacuum at idle.....	600 mm/Hg (23.6 In/Hg)
Belt Tension.....	47 ± 3 DaN
Thermostat Opening.....	80°C ± 2°C
Generator Rating.....	Denso 130A
Cooling System Capacity.....	9.5 Liter
P/S Capacity.....	0.75 Liter
Engine Oil Capacity.....	7.5 Liter w/filter change
Timing System.....	Pushrod operated overhead valves, with gear-driven camshaft in crankcase.
Air Intake.....	Dry filter.
Fuel feed.....	Vane pump incorporated in injection pump.
Fuel System.....	Indirect fuel injection (precombustion chamber).
Combustion Cycle.....	4 stroke.
Cooling System.....	Water cooling.
Injection Pump.....	Rotary pump with electronic management.
Lubrication.....	Pressure lubrication by rotary pump, full-flow filtration.
Engine Rotation.....	Clockwise viewed from front cover.

80bcea0f

Engine Description

Check the oil level after the engine reaches normal operating temperature. Allow 5 minutes to stabilize oil level, check dipstick. The oil level in the pan should never be above the FULL mark or below the ADD OIL mark on dipstick. Either of these 2 conditions could be responsible for noisy tappets:

OIL LEVEL HIGH

If oil level is above the FULL mark, it is possible for the connecting rods to dip into the oil. With the engine running, this condition could create foam in the oil pan. Foam in oil pan would be fed to the hydraulic tappets by the oil pump causing them to lose length and allow valves to seat noisily.

OIL LEVEL LOW

Low oil level may allow oil pump to take in air. When air is fed to the tappets, they lose length which allows valves to seat noisily. Any leaks on intake side of oil pump through which air can be drawn will create the same tappet action. Check the lubrication system from the intake strainer to the pump cover, including the relief valve retainer cap. When tappet noise is due to aeration, it may be intermittent or constant, and usually more than 1 tappet will be noisy. When oil level and leaks have been corrected, operate the engine at fast idle. Run engine for a sufficient time to allow all of the air inside the tappets to be bled out.

DIAGNOSIS AND TESTING

SERVICE DIAGNOSIS—DIESEL—PERFORMANCE

CONDITION	POSSIBLE CAUSES	CORRECTION
ENGINE WILL NOT CRANK OR CRANKS SLOWLY	<ol style="list-style-type: none"> 1. Starting motor operating, but not cranking the engine. 2. Crankshaft rotation restricted. 3. Starting circuit connections loose or corroded. 4. Neutral safety switch or starter relay inoperative. 5. Battery charge low. 6. No voltage to starter solenoid. 7. Solenoid or starter motor inoperative. 	<ol style="list-style-type: none"> 1. Remove the starter motor. Check for broken flywheel teeth or a broken starting motor spring. 2. Rotate the engine to check for rotational resistance. 3. Clean and tighten connections. 4. Check starter relay supply voltage and proper operation of neutral safety switch (if equipped). Replace defective parts. 5. Check battery voltage. Replace battery if a charge cannot be held. 6. Check voltage to solenoid. If necessary, replace the solenoid. 7. Replace starter motor.
ENGINE CRANKS, BUT WILL NOT START NO SMOKE	<ol style="list-style-type: none"> 1. No fuel in supply tank. 2. Electrical fuel shutdown solenoid not operating. 3. Exhaust plugged. 4. Fuel filter plugged. 5. Excessive fuel inlet restriction. 6. Injection pump not getting fuel or fuel is aerated. 7. Worn or inoperative injection pump. 	<ol style="list-style-type: none"> 1. Fill fuel supply. 2. Check for loose wires and verify that the fuel shutdown solenoid and fuel shutdown solenoid relay is functioning. 3. Remove the obstruction. 4. Drain fuel/water separator and replace fuel filter. 5. Check fuel inlet restriction. Correct cause. 6. Check fuel flow/bleed fuel system. 7. Visually check delivery with externally connected injector to one of the pump outlets. Repair or replace the pump if fuel is not being delivered.
ENGINE HARD TO START, OR WILL NOT START SMOKE FROM EXHAUST	<ol style="list-style-type: none"> 1. Incorrect starting procedure. 2. Cranking speed too slow. 3. Cylinder heads heater plugs relay defective. 4. One or more cylinder head heater plugs defective. 5. Insufficient intake air. 	<ol style="list-style-type: none"> 1. The fuel shutoff solenoid control must be in the run position. Ensure proper procedure is being used. 2. (A) Verify that the transmission is not engaged. (B) Check the battery, starting motor and look for loose or corroded wiring connections. 3. Verify system is working. Repair/replace inoperative parts. 4. Verify system is working. Repair/replace inoperative parts. 5. Inspect or replace filter and check for obstruction to the air supply tube.

DIAGNOSIS AND TESTING (Continued)

CONDITION	POSSIBLE CAUSES	CORRECTION
ENGINE HARD TO START, OR WILL NOT START SMOKE FROM EXHAUST (CONT.)	<ul style="list-style-type: none"> 6. Air in fuel system or the fuel supply is inadequate. 7. Contaminated fuel. 8. Fuel screen plugged. 9. One or more injectors worn or not operating properly. 10. Worn or inoperative injection pump. 11. Injection pump out of time. 12. Engine compression low. 13. Camshaft out of time. 	<ul style="list-style-type: none"> 6. Check the flow through the filter and bleed the system. Locate and eliminate the air source. 7. Verify by operating the engine with clean fuel from a temporary tank. Check for presence of gasoline. Drain and flush fuel supply tank. Replace fuel/water separator filter. 8. Check fuel screen. 9. Check/replace improperly operating injectors. 10. Visually check fuel delivery with an externally connected injector to one of the pump outlets. Repair or replace the pump if fuel is not being delivered. 11. Check/Time the pump (refer to Group 14, Fuel System). 12. Check compression to identify the problem. 13. Check camshaft timing.
ENGINE STARTS, BUT WILL NOT KEEP RUNNING	<ul style="list-style-type: none"> 1. Cylinder heads heater plugs relay defective. 2. One or more cylinder head heater plugs defective. 3. Intake air or exhaust system restricted. 4. Air in the fuel system or the fuel supply is inadequate. 5. Fuel waxing due to extremely cold weather. 6. Contaminated fuel. 	<ul style="list-style-type: none"> 1. Verify system is working. Repair/replace inoperative parts. 2. Verify system is working. Repair/replace inoperative parts. 3. Visually check for exhaust restriction and inspect the air intake. Repair/replace restricting parts. 4. Check flow through the filter and bleed the system. Locate and eliminate the air source. 5. Verify by inspecting the fuel filter. Clean the system and use climatized fuel. Replace fuel/water separator filter. Check fuel heater for proper operation. 6. Verify by operating the engine with clean fuel from a temporary supply tank. Check for presence of gasoline. Replace fuel/water separator filter.
SURGING (SPEED CHANGE)	<ul style="list-style-type: none"> 1. If the condition occurs at idle, the idle speed is set too low for the accessories. 2. High pressure fuel leak. 3. One or more injectors worn or not operating properly. 4. Improperly operating injection pump. 	<ul style="list-style-type: none"> 1. Adjust the idle speed. 2. Inspect/correct leaks in the high pressure lines. Fitting and delivery valve sealing washers. 3. Check/replace the inoperative injectors. 4. Replace the injector pump.

DIAGNOSIS AND TESTING (Continued)

CONDITION	POSSIBLE CAUSES	CORRECTION
<p>ROUGH IDLE (IRREGULARLY FIRING OR ENGINE SHAKING)</p>	<ol style="list-style-type: none"> 1. If engine is cold, glow plug relay on glow plug(s) defective. 2. Engine mounts damaged or lose. 3. High pressure fuel leaks. 4. Air in the fuel system. 5. Sticking needle valve in an injector. 	<ol style="list-style-type: none"> 1. Refer to troubleshooting for cylinder head heater plugs (see Group 14, Fuel System). 2. Repair or replace mounts. 3. Correct leaks in the high pressure lines, fittings or delivery valves. 4. Bleed the fuel system and eliminate the source of the air. 5. Check and replace the injector with the sticking needle valve.
<p>ENGINE RUNS ROUGH</p>	<ol style="list-style-type: none"> 1. Fuel injection lines leaking. 2. Air in the fuel or the fuel supply is inadequate. 3. Contaminated fuel. 4. Incorrect valve operation. 5. Injection pump timing incorrect. 6. Improperly operating injectors. 7. Defective injection pump (delivery valve). 8. Camshaft out of time. 9. Damaged camshaft or tappets. 10. Automatic timing advance not operating. 	<ol style="list-style-type: none"> 1. Correct leaks in the high pressure lines, fittings, injectors sealing washers or delivery valves. 2. Check the flow through the filter and bleed the system. Locate and eliminate the air source. 3. Verify by operating the engine with clean fuel from a temporary supply tank. Check for presence of gasoline. Replace fuel/water separator filter. 4. Check for a bent push rod and adjust valves. Replace push rod, if necessary. 5. Check/time pump (refer to Group 14, Fuel System). 6. Replace inoperative injectors. 7. Repair or replace injection pump. 8. Check/correct gear train timing alignment. 9. Inspect camshaft valve lift. Replace camshaft and tappets. 10. Check injection pump. Check fuel injector sensor at number 1 cylinder injector.
<p>ENGINE RPM WILL NOT REACH RATED SPEED</p>	<ol style="list-style-type: none"> 1. Engine overload. 2. Improperly operating tachometer. 3. Inadequate fuel supply. 4. Air/fuel controls leak. 	<ol style="list-style-type: none"> 1. Verify high idle speed without load. Investigate operation to be sure correct gear is being used. 2. Verify engine speed with hand tachometer, correct as required. 3. Check the fuel flow through the system to locate the reason for inadequate fuel supply, correct as required. 4. Check and repair leak. Check AFC tubing for obstruction.

DIAGNOSIS AND TESTING (Continued)

CONDITION	POSSIBLE CAUSES	CORRECTION
ENGINE RPM WILL NOT REACH RATED SPEED (CONT.)	6. Improperly operating injection pump.	6. Repair or replace injection pump.
LOW POWER	<ol style="list-style-type: none"> 1. Fuel control lever not moving to full throttle. 2. High oil level. 3. Engine overloaded. 4. Slow throttle response caused by leaking or obstructed air control tube or improperly operating control in the pump. 5. Inadequate intake air flow. 6. Inadequate fuel supply. Air in the fuel. 7. Excessive exhaust restriction. 8. High fuel temperature. 9. Poor quality fuel or fuel contaminated with gasoline. 10. Air leak between the turbocharger and the intake manifold. 11. Exhaust leak at the manifold or turbocharger. 12. Improperly operating turbocharger. 13. Wastegate operation. 14. Valve not operating. 15. Worn or improperly operating injectors. 16. Incorrect injection pump timing. 17. Improperly operating injection pump. 	<ol style="list-style-type: none"> 1. Check/correct for stop-to-stop travel. 2. Check/correct oil level. 3. Check for added loading from accessories or driven units, brakes dragging and other changes in vehicle loading. Repair/replace as needed. 4. Check for leaks and obstructions. Tighten the fittings. Repair or replace the pump if the controls are not functioning. 5. Inspect/replace air cleaner element. Look for other restrictions. 6. Check the flow through the filter to locate the source of the restriction. Check fuel pressure and inlet restriction. 7. Check/correct the restriction in the exhaust system. 8. Verify that fuel heater is off when engine is warm. Check for restricted fuel drain tubes. Repair/replace as needed. 9. Verify by operating from a temporary tank with good fuel. Check for presence of gasoline. Replace fuel/water separator filter. 10. Check/correct leaks in hoses, gaskets, charge air cooler and around mounting capscrews or through holes in the manifold cover. 11. Check/correct leaks in the manifold or turbocharger gaskets. If manifold is cracked, replace manifold. 12. Inspect/replace turbocharger. 13. Check wastegate operation. 14. Check for bent push rod, replace if necessary. 15. Check/replace injectors. 16. Verify injection pump timing (see Group 14, Fuel System). 17. Repair or replace injection pump.

DIAGNOSIS AND TESTING (Continued)

CONDITION	POSSIBLE CAUSES	CORRECTION
<p>EXCESSIVE EXHAUST SMOKE</p>	<ol style="list-style-type: none"> 1. Engine running too cold (white smoke). 2. Improper starting procedure (white smoke). 3. Fuel supply inadequate. 4. Injection pump timing. 5. Inadequate intake air. 6. Air leak between turbocharger and intake manifold. 7. Exhaust leak at the manifold or turbocharger. 8. Improperly operating turbocharger. 9. Improperly operating injectors. 10. Improperly operating or overfueled injector pump. 11. Piston rings not sealing (blue smoke). 	<ol style="list-style-type: none"> 1. Refer to troubleshooting for coolant temperature below normal (refer to Group 7, Cooling System). Inspect cylinder head heater plugs for proper operation. 2. Use proper starting procedures. 3. Check fuel supply pressure and inlet restriction. 4. Check and time pump (refer to Group 14, Fuel System). 5. Inspect/change air filter. Look for other restriction. Check charge air cooler for obstructions. 6. Check/correct leaks in the air crossover tube, hoses, gaskets, mounting capscrews or through holes in the manifold cover. 7. Check/correct leaks in the manifold or turbocharger gaskets. If cracked replace manifold. 8. Inspect/replace turbocharger. 9. Check and replace inoperative injectors. 10. Repair or replace injection pump. 11. Perform blow-by check. Correct as required.
<p>ENGINE WILL NOT SHUT-OFF</p>	<ol style="list-style-type: none"> 1. Fuel shutoff solenoid inoperative. 2. Engine running on fumes drawn into the air intake. 3. Fuel injection pump malfunction. 	<ol style="list-style-type: none"> 1. Check/replace fuel shutoff solenoid. 2. Check the air intake ducts for the source of fumes. WARNING: In case of engine runaway due to flammable fumes from gasoline spills or turbocharger oil leaks being sucked into the engine, shut off engine ignition switch first then use a CO2 fire extinguisher and direct the spray under the front bumper to remove oxygen supply. The engine air intake is on the passenger side behind the bumper. The fire extinguisher must be directed at this location for emergency shutdown conditions. 3. Repair or replace fuel injection pump.

DIAGNOSIS AND TESTING (Continued)

CONDITION	POSSIBLE CAUSES	CORRECTION
COOLANT TEMPERATURE ABOVE NORMAL	<ol style="list-style-type: none"> 1. Low coolant level. 2. Incorrect/improperly operating pressure cap. 3. Loose drive belt on water pump/fan. 4. Inadequate air flow to the radiator. 5. Radiator fins plugged. 6. Collapsed radiator hose. 7. Improperly operating temperature sensor/gauge. 8. Improperly operating, incorrect or no thermostat. 9. Air in the cooling system. 10. Inoperative water pump. 11. Incorrect injection pump timing. 12. Overfueled injection pump. 13. Plugged cooling passages in radiator, head, head gasket or block. 14. Engine overloaded. 	<ol style="list-style-type: none"> 1. Check coolant level. Add coolant, if necessary. Locate and correct the source of the coolant loss, (refer to Group 7, Cooling). 2. Replace cap with the correct rating for the system. 3. Check/replace belt or belt tensioner. 4. Check/repair radiator core, fan shroud and viscous fan drive as required. 5. Blow debris from fins. 6. Replace the hose. Check coolant tank cap operation, (refer to Group 7, Cooling Tanks). 7. Verify that the gauge and temperature sensor are accurate. Replace gauge/sensor, if bad. 8. Check and replace the thermostat. 9. (A) make sure the fill rate is not being exceeded and the correct vented thermostat is installed. (B) Check for loose hose clamps. Tighten if loose. (C) If aeration continued, check for a compression leak through the head gasket. 10. Check and replace the water pump. 11. Verify pump timing marks are aligned. Check/time the injector pump (refer to Group 14, Fuel System). 12. Repair or replace the injection pump. 13. Flush the system and fill with clean coolant. 14. Verify that the engine load rating is not being exceeded.
COOLANT TEMPERATURE BELOW NORMAL	<ol style="list-style-type: none"> 1. Too much air flow across the radiator. 2. Incorrect thermostat or contamination in thermostat. 3. Temperature sensor or gauge inoperative. 4. Coolant not flowing by temperature sensor. 	<ol style="list-style-type: none"> 1. Check/repair viscous fan drive as required. 2. Check and replace thermostat. 3. Verify that the gauge and sensor are accurate. If not, replace gauge/sensor. 4. Check and clean coolant passages.

DIAGNOSIS AND TESTING (Continued)

SERVICE DIAGNOSIS—DIESEL—MECHANICAL.

CONDITION	POSSIBLE CAUSES	CORRECTION
LUBRICATING OIL PRESSURE LOW	<ol style="list-style-type: none"> 1. Low oil level. 2. Oil viscosity thin, diluted or wrong specification. 3. Improperly operating pressure switch/gauge. 4. Relief valve stuck open. 5. If cooler was replaced, shipping plugs left in cooler. 6. Worn oil pump. 7. Suction tube loose or seal leaking. 8. Loose main bearing cap. 9. Worn bearings or wrong bearings installed. 10. Oil jet under piston bad fit into cylinder block. 	<ol style="list-style-type: none"> 1. (A) Check and fill with clean engine oil. (B) Check for a severe external oil leak that could reduce the pressure. 2. Verify the correct oil is being used. Check for oil dilution. 3. Verify the pressure switch is functioning correctly. If not, replace switch/gauge. 4. Check/replace valve. 5. Check/remove shipping plugs. 6. Check and replace oil pump. 7. Check and replace seal. 8. Check and install new bearing and tighten cap to proper torque. 9. Inspect and replace connecting rod or main bearings. Check and replace piston cooling nozzles. 10. Check oil jet position.
LUBRICATING OIL PRESSURE TOO HIGH	<ol style="list-style-type: none"> 1. Pressure switch/gauge not operating properly. 2. Engine running too cold. 3. Oil viscosity too thick. 4. Oil pressure relief valve stuck closed or binding. 	<ol style="list-style-type: none"> 1. Verify the pressure switch is functioning correctly. If not, replace switch/gauge. 2. Refer to Coolant Temperature Below Normal (Engine Diagnosis Performance). 3. Make sure the correct oil being used, (Refer to Group 0, Lubrication and Maintenance). 4. Check and replace valve.
LUBRICATING OIL LOSS	<ol style="list-style-type: none"> 1. External leaks. 2. Crankcase being overfilled. 3. Incorrect oil specification or viscosity. 4. Oil cooler leak. 5. High blow-by forcing oil out the breather. 	<ol style="list-style-type: none"> 1. Visually inspect for oil leaks. Repair as required. 2. Verify that the correct dipstick is being used. 3. (A) Make sure the correct oil is being used. (B) Look for reduced viscosity from dilution with fuel. (C) Review/reduce the oil change intervals. 4. Check and replace the oil cooler. 5. Check the breather tube area for signs of oil loss. Perform the required repairs.

DIAGNOSIS AND TESTING (Continued)

CONDITION	POSSIBLE CAUSES	CORRECTION
LUBRICATING OIL LOSS (CONT.)	<ol style="list-style-type: none"> 6. Turbocharger leaking oil to the air intake. 7. Piston rings not sealing (oil being consumed by the engine). 	<ol style="list-style-type: none"> 6. Inspect the air ducts for evidence of oil transfer. Repair as required. 7. Perform blow-by check. Repair as required.
COMPRESSION KNOCKS	<ol style="list-style-type: none"> 1. Poor quality fuel or water/gasoline contaminated fuel. 2. Incorrect injection pump timing. 3. Improperly operating injectors. 4. Wrong injection pump timing. 	<ol style="list-style-type: none"> 1. Verify by operating from a temporary tank with good fuel. Clean and flush the fuel supply tanks. Replace fuel/water separator. 2. Check and time injection pump (refer to Group 14, Fuel System). 3. Check and replace inoperative injectors. 4. Check injection pump timing.
EXCESSIVE VIBRATION	<ol style="list-style-type: none"> 1. Loose or broken engine mounts. 2. Damaged fan or improperly operating accessories. 3. Improperly operating vibration damper. 4. Improperly operating viscous fan drive. 5. Worn or damaged generator bearing. 6. Flywheel housing misaligned. 7. Loose or broken power component. 8. Worn or unbalanced driveline components. 	<ol style="list-style-type: none"> 1. Replace engine mounts. 2. Check and replace the vibrating components. 3. Inspect/replace the vibration damper. 4. Inspect/replace the fan drive. 5. Check/replace the generator. 6. Check/correct flywheel alignment. 7. Inspect the crankshaft and rods for damage that causes an unbalance. Repair/replace as required. 8. Check/repair driveline components.
EXCESSIVE ENGINE NOISES	<ol style="list-style-type: none"> 1. Drive belt squeal, insufficient tension or abnormally high loading. 2. Intake air or exhaust leaks. 3. Turbocharger noise. 4. Gear train noise. 5. Power function knock. 	<ol style="list-style-type: none"> 1. Check the automatic tensioner and inspect the drive belt. Make sure water pump, tensioner pulley, fan hub and generator turn freely. 2. Refer to Excessive Exhaust smoke (Engine Diagnosis Performance). 3. Check turbocharger impeller and turbine wheel for housing contact. Repair/replace as required. 4. Visually inspect and measure gear backlash. Replace gears as required. 5. Check/replace rod and main bearings.

DIAGNOSIS AND TESTING (Continued)

CONDITION	POSSIBLE CAUSES	CORRECTION
GENERATOR NOT CHARGING OR INSUFFICIENT CHARGING	<ol style="list-style-type: none">1. Loose or corroded battery.2. Generator belt slipping.3. Generator pulley loose on shaft.4. Improperly operating generator.	<ol style="list-style-type: none">1. Clean/tighten battery connection.2. Check/replace automatic belt tensioner. Check/replace and adjust belt.3. Tighten pulley.4. Check/replace generator.

DIAGNOSIS AND TESTING (Continued)

TAPPET NOISE

(1) To determine source of tappet noise, operate engine at idle with cylinder head covers removed.

(2) Feel each valve spring or rocker arm to detect noisy tappet. The noisy tappet will cause the affected spring and/or rocker arm to vibrate or feel rough in operation.

NOTE: Worn valve guides or cocked springs are sometimes mistaken for noisy tappets. If such is the case, noise may be dampened by applying side thrust on the valve spring. If noise is not appreciably reduced, it can be assumed the noise is in the tappet. Inspect the rocker arm push rod sockets and push rod ends for wear.

(3) Valve tappet noise ranges from light noise to a heavy click. A light noise is usually caused by excessive leak down around the unit plunger or by the plunger partially sticking in the tappet body cylinder. The tappet should be replaced. A heavy click is caused by a tappet check valve not seating or by foreign particles becoming wedged between the plunger and the tappet body. This will cause the plunger to stick in the down position. This heavy click will be accompanied by excessive clearance between the valve stem and rocker arm as valve closes. In either case, tappet assembly should be removed for inspection and cleaning.

The valve train generates a noise very much like a light tappet noise during normal operation. Care must be taken to ensure that tappets are making the noise. In general, if more than one tappet seems to be noisy, its probably not the tappets.

SERVICE PROCEDURES

VALVE SERVICE

This procedure is done with the engine cylinder head removed from the block.

DISASSEMBLY

(1) Remove the engine cylinder head from the cylinder block. Refer to cylinder head removal and installation in this section.

(2) Use Valve Spring Compressor Tool and compress each valve spring.

(3) Remove the valve locks, retainers, and springs.

(4) Use an Arkansas smooth stone or a jewelers file to remove any burrs on the top of the valve stem, especially around the groove for the locks.

(5) Remove the valves, and place them in a rack in the same order as removed.

VALVE CLEANING

(1) Clean all carbon deposits from the combustion chambers, valve ports, valve stems, valve stem guides and head.

(2) Clean all grime and gasket material from the engine cylinder head machined gasket surface.

INSPECTION

(1) Inspect for cracks in the combustion chambers and valve ports.

(2) Inspect for cracks on the exhaust seat.

(3) Inspect for cracks in the gasket surface at each coolant passage.

(4) Inspect valves for burned, cracked or warped heads.

(5) Inspect for scuffed or bent valve stems.

(6) Replace valves displaying any damage.

(7) Check valve spring height (Fig. 2).

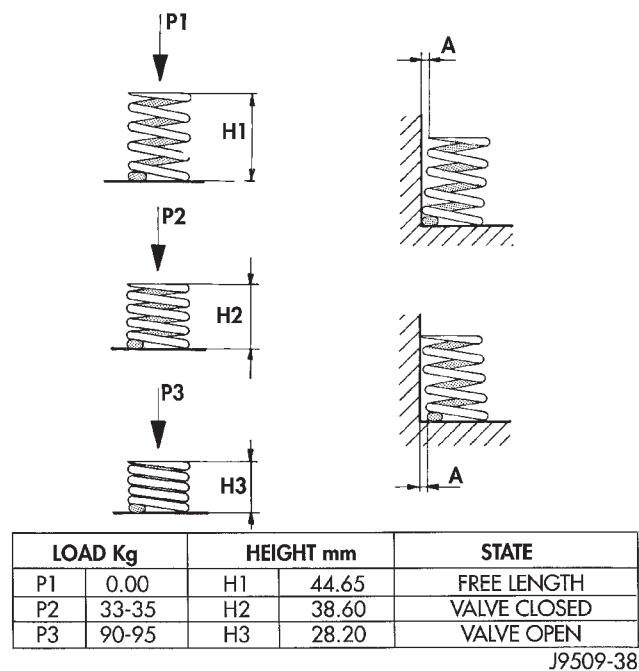

Fig. 2 Valve Spring Chart

VALVE REFACING

(1) Use a valve refacing machine to reface the intake and exhaust valves to the specified angle.

(2) After refacing, a margin of at least 4.52-4.49 mm (.178-.177 inch) must remain (Fig. 3). If the margin is less than 4.49 mm (.177 inch), the valve must be replaced.

VALVE SEAT REFACING

(1) Install a pilot of the correct size in the valve guide bore. Reface the valve seat to the specified angle with a good dressing stone. Remove only enough metal to provide a smooth finish.

(2) Use tapered stones to obtain the specified seat width when required.

SERVICE PROCEDURES (Continued)

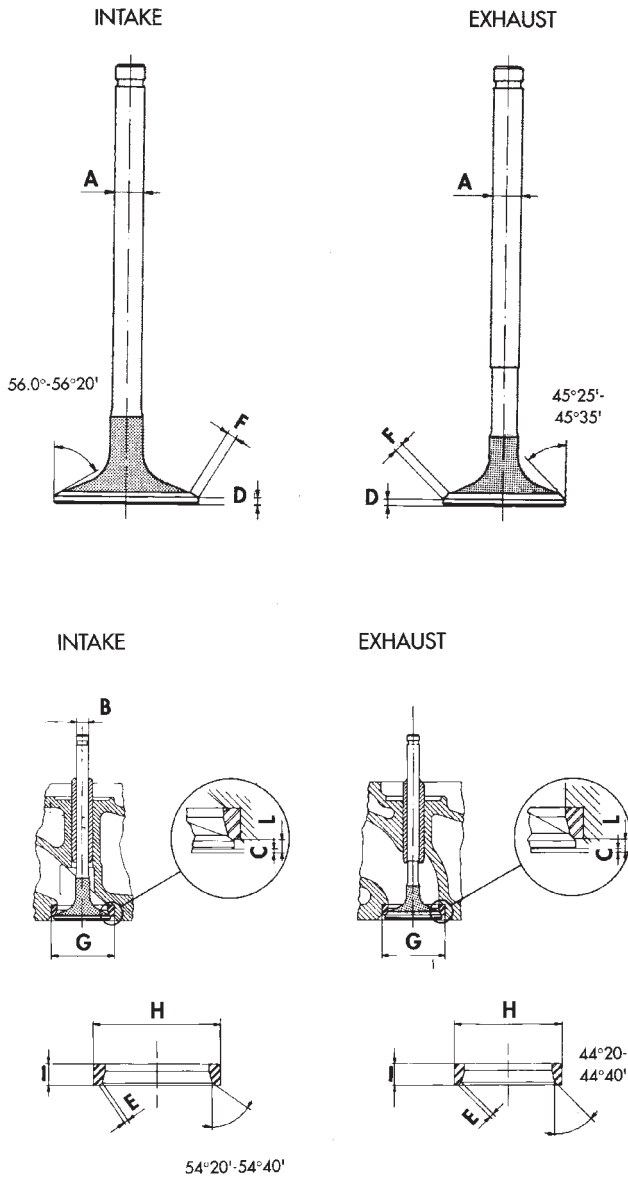

MEASUREMENT	INTAKE	EXHAUST
A	7.940-7.960	7.922-7.940
B	8.00-8.015	8.000-8.015
C	0.880-1.140	0.990-1.250
D	2.2±0.08	2.09 ^{+0.07} / _{0.05}
E	1.80-2.20	1.65-2.05
F	2.73-3.44	2.45-3.02
G	41.962-41.985	35.964-35.987
H	42.070-42.086	36.050-36.066
I	7.14-7.19	7.00-7.05
L	3.11-3.26	3.10-3.25

Fig. 3 Valve Specification

J9509-40

VALVE STAND DOWN

Valve stand down is to maintain the adequate compression ratio.

- (1) Invert cylinder head.
- (2) Fit each valve to its respective valve guide.
- (3) Using a straight edge and feeler gauge (Fig. 4), check valve head stand down: Inlet valve head stand down .80 to 1.2 mm (.031 to .047 in.) and exhaust valve stand down .79 to 1.19 mm (.031 to .047 in.).
- (4) If valve head stand down is not in accordance with above, discard original valves, check stand down with new valves and recut valve seat inserts to obtain correct stand down.

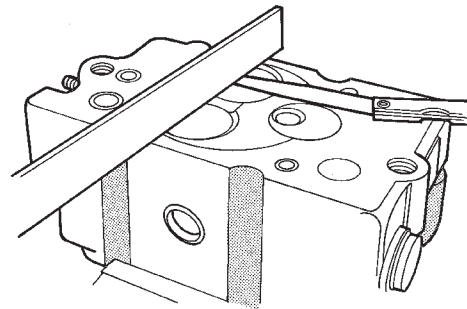

J9509-166

Fig. 4 Checking Valve Stand Down

VALVE GUIDES

- (1) Valve Guides height requirement.
- (2) Measurement A (Fig. 5): 13.50 - 14.00 mm.

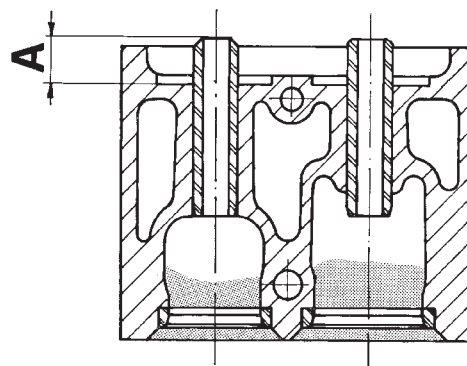

J9509-36

Fig. 5 Valve Guide Height

VALVE STEM-TO-GUIDE CLEARANCE MEASUREMENT

- (1) Measure and record internal diameter of valve guides. Valve guide internal diameter is 8.0 to 8.015 mm (.3149 to .3155 ins.).
- (2) Measure valve stems and record diameters. Intake valve stem diameter 7.94 to 7.96 mm (.3125 to .3133 in). Exhaust valve stem diameter 7.92 to 7.94 mm (.3118 to .31215 in).

SERVICE PROCEDURES (Continued)

(3) Subtract diameter of valve stem from internal diameter of its respective valve guide to obtain valve stem clearance in valve guide. Clearance of inlet valve stem in valve guide is .040 to .075 mm (.0015 to .0029 in). Clearance of exhaust valve stem in valve guide is .060 to .095 mm (.0023 to .0037 in).

(4) If valve stem clearance in valve guide exceeds tolerances, new valve guides must be installed.

REMOVAL AND INSTALLATION

3.1L TURBO DIESEL ENGINE

REMOVAL

(1) Disconnect and isolate the negative battery cable.

(2) Mark the hinge locations on the hood for alignment reference during installation.

(3) Disconnect the engine compartment lamp.

(4) With assistance from another person, remove the hood.

(5) Cover both fenders to prevent paint damage.

WARNING: DO NOT LOOSEN THE RADIATOR VENT OR DRAINCOCK WITH THE SYSTEM HOT AND PRESSURIZED. SERIOUS BURNS FROM COOLANT CAN OCCUR

(6) Open the cooling system vent. Located on top of the radiator.

(7) Raise the vehicle on the hoist

(8) Remove both of the front splash shields (Fig. 6).

(9) Drain the cooling system. Refer to Group 7, Cooling System for the procedure.

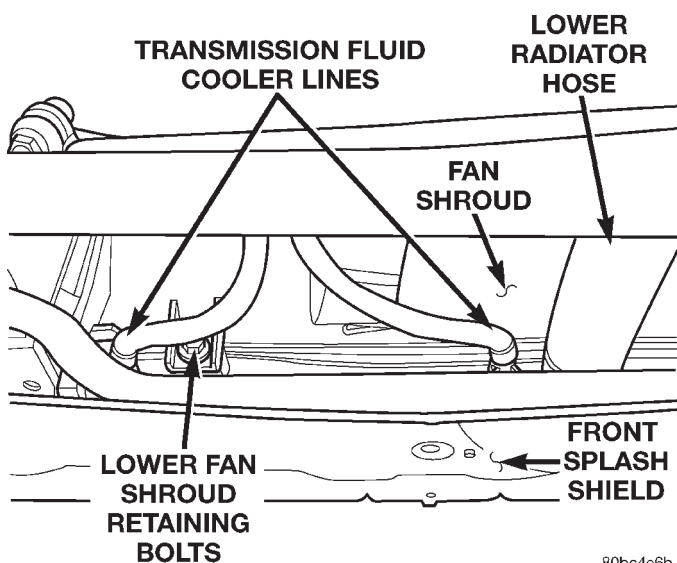

Fig. 6 Transmission Fluid Cooler Lines

(10) Remove the transmission fluid cooler lines from the radiator (Fig. 6).

(11) Remove the lower radiator hose from the radiator (Fig. 6).

(12) Remove the lower fan shroud retaining bolts (Fig. 6).

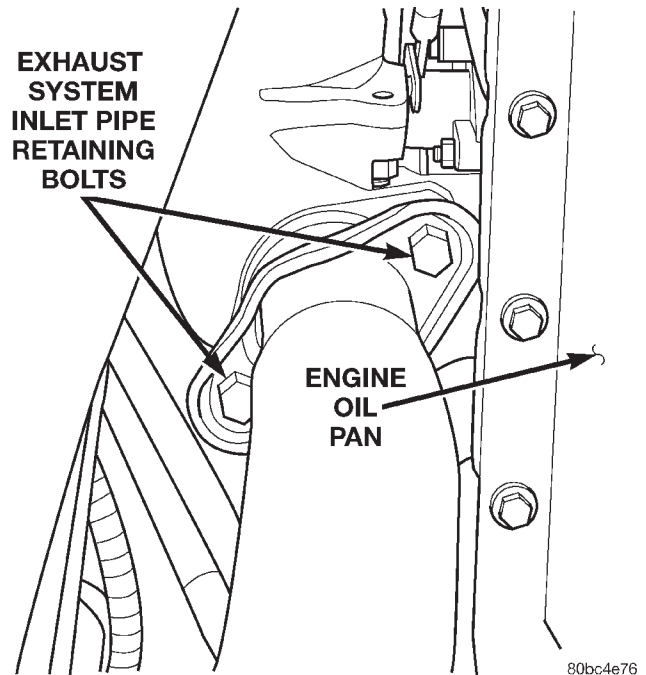

Fig. 7 Exhaust System Inlet Pipe

(13) Remove the exhaust system inlet pipe retaining bolts from the turbocharger (Fig. 7).

(14) Remove the nut retaining the wire harnesses on the left engine mount.

(15) Lower the vehicle on the hoist.

(16) Remove the right and left headlamp assemblies from the vehicle. Refer to Group 8L, Lamps for the procedure.

(17) Remove the front fascia. Refer to Group 13, Frame and Bumpers for the procedure.

(18) Disconnect the ambient temperature sensor and unclip the wire harness from the headlamp module mounting assembly.

(19) Disconnect the right and left headlamp module wire harnesses at the 10-way connectors. Located just above the front bumper to the right and left of the A/C condenser.

(20) Remove the headlamp module mounting (HMM) assembly. Refer to Group 23, Body for the procedure.

NOTE: Mark the position of the hood latch in relation to its mounting bracket. This will aid in aligning the hood latch during reassembly.

(21) Remove the hood latch retaining fasteners and position it out of the way.

REMOVAL AND INSTALLATION (Continued)

- (22) Remove the hood latch support brackets from the vehicle.
- (23) Remove the upper fan shroud retaining bolts.
- (24) Remove the radiator crossmember from the vehicle.
- (25) Remove the manual cooling fan and let set inside of the fan shroud.

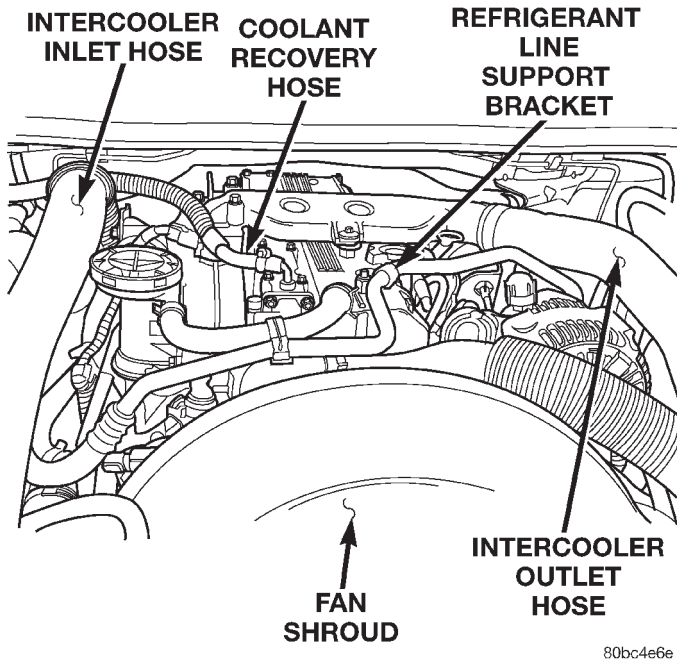

Fig. 8 Intercooler Hoses

- (26) Remove the intercooler inlet and outlet hoses from the vehicle (Fig. 8).

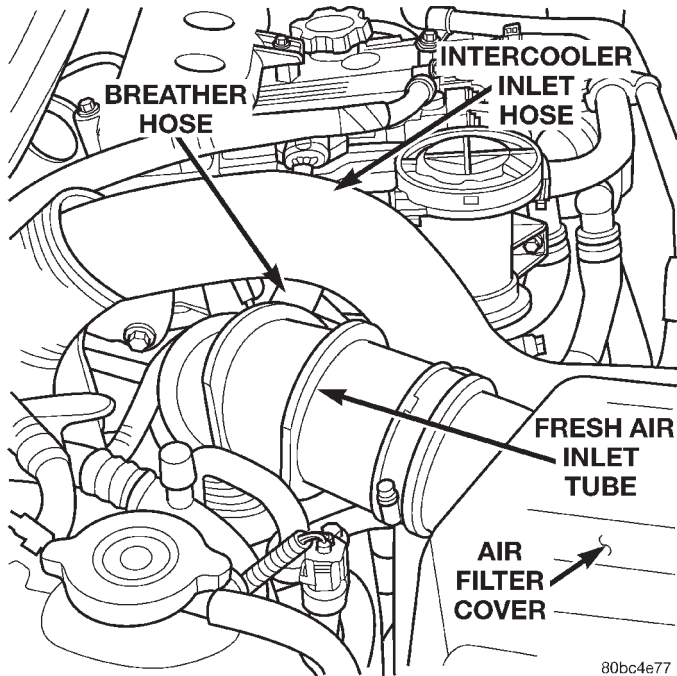

Fig. 9 Air Intake Hoses

- (27) Disconnect the breather hose and remove the fresh air inlet tube from the vehicle (Fig. 9).
- (28) Remove the radiator overflow hose from the radiator
- (29) Remove the upper radiator hose from the vehicle.
- (30) Disconnect the electric radiator cooling fan electrical connector.
- (31) If equipped, recover the refrigerant. Refer to Group 24, Heating and Air Conditioning for the procedure.

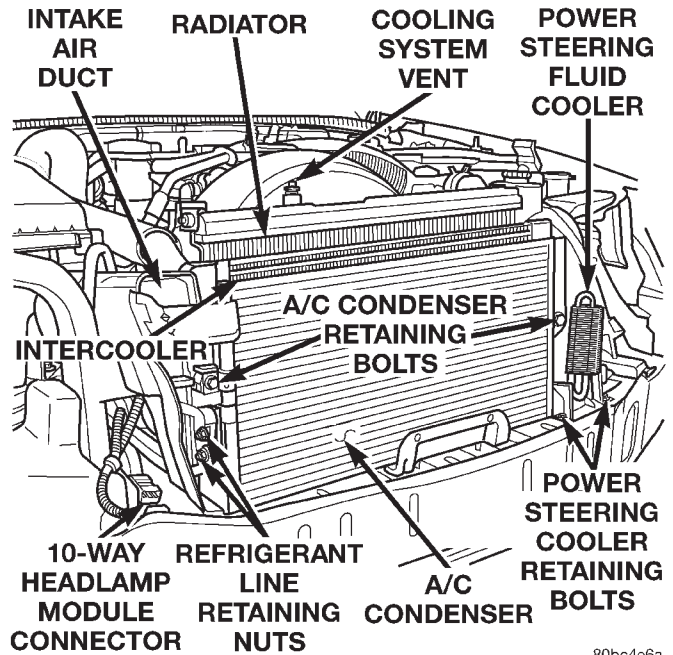

Fig. 10 Cooling Module Assembly

- (32) Remove the intake air duct from the vehicle (Fig. 10).
- (33) Remove the power steering cooler retaining bolts (Fig. 10) and position the cooler aside.
- (34) Remove the suction and discharge lines from the condenser assembly (Fig. 10).
- (35) Remove the fan shroud and both cooling fans as an assembly from the vehicle.

NOTE: The cooling module assembly includes the radiator, intercooler and A/C condenser.

- (36) Remove the cooling module assembly retaining bolts and remove the cooling module from the vehicle.
- (37) Remove the coolant reservoir supply hose from the engine .
- (38) Remove the coolant recovery hose from the water manifold.
- (39) Remove the EGR valve vacuum supply line from the valve (Fig. 11).

REMOVAL AND INSTALLATION (Continued)

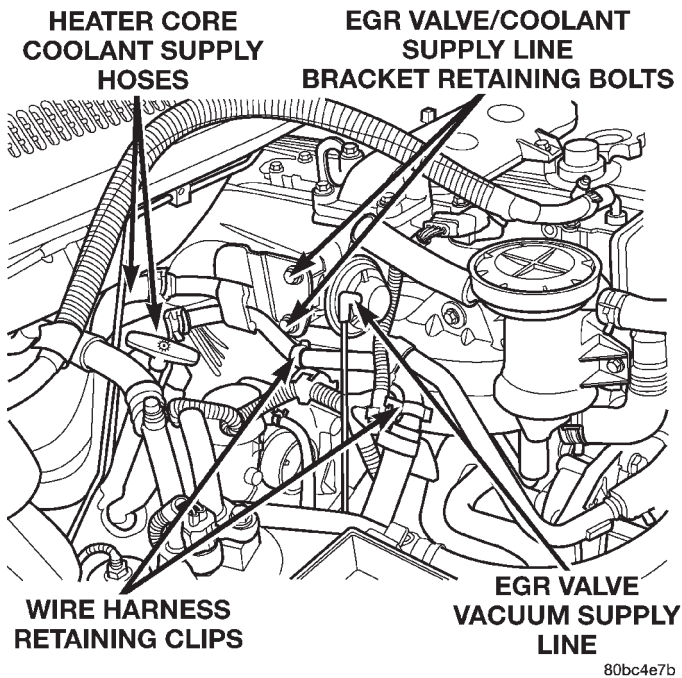

Fig. 11 Engine Compartment View - Rightside

(40) Remove the heater core coolant supply lines from the engine assembly (Fig. 11).

(41) Remove the refrigerant line from the A/C accumulator assembly.

(42) Disconnect the oil pressure and boost pressure sensor electrical connectors and unclip wire harness from the coolant supply lines.

(43) Disconnect the engine ground. Located just behind the oil filter.

(44) Remove the refrigerant line retaining nut from the bulkhead and remove the refrigerant liquid line from the vehicle.

(45) Cut the tiestraps retaining the wire harness to the refrigerant line. Located above the compressor assembly.

(46) Remove the refrigerant line support bracket bolt from the cylinder head cover.

(47) Remove both of the refrigerant line retaining bolts from the compressor and remove the lines from the vehicle.

(48) Remove the power steering fluid supply hose from the pump (Fig. 12).

(49) Remove the power steering fluid pressure line from the pump (Fig. 12).

(50) Remove the vacuum supply hose from the engine mounted steel vacuum source line.

(51) Disconnect the generator field wire connector from the rear of the generator.

(52) Unclip the battery feed wire cover and remove the wire from the top of the generator.

(53) Disconnect the speed control servo vacuum supply hose from the engine mounted steel vacuum source line.

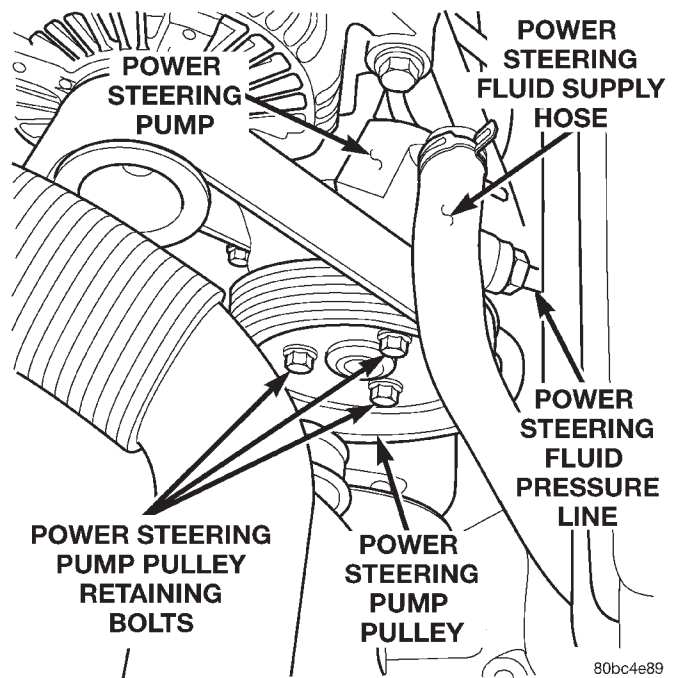

Fig. 12 Power Steering Fluid Lines At Pump

(54) Disconnect the fuel supply and return hoses from the engine assembly.

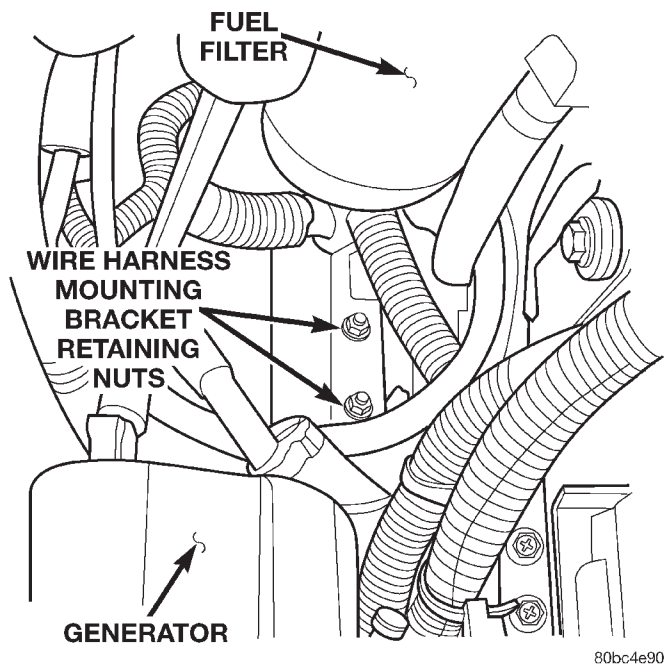

Fig. 13 Wire Harness Mounting Bracket

(55) Remove the wire harness mounting bracket retaining nuts from the left engine mount (Fig. 13).

(56) Disconnect the black and gray 10-way electrical connectors from the engine wire harness.

(57) Disconnect the A/C compressor clutch and glow plug harness electrical connectors.

REMOVAL AND INSTALLATION (Continued)

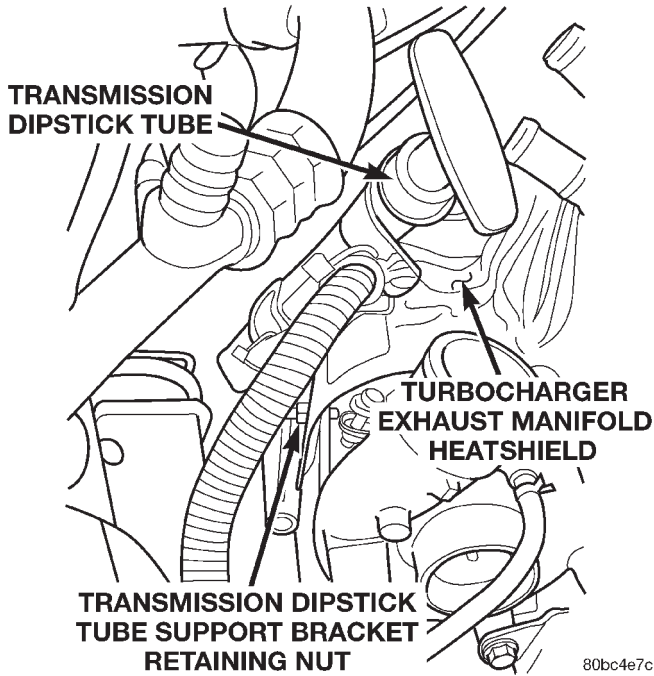

Fig. 14 Transmission Dipstick Tube Support Bracket

(58) Remove the transmission dipstick tube support bracket retaining nut from the turbocharger heatshield (Fig. 14).

(59) Raise the vehicle on the hoist.

(60) Disconnect the starter motor electrical.

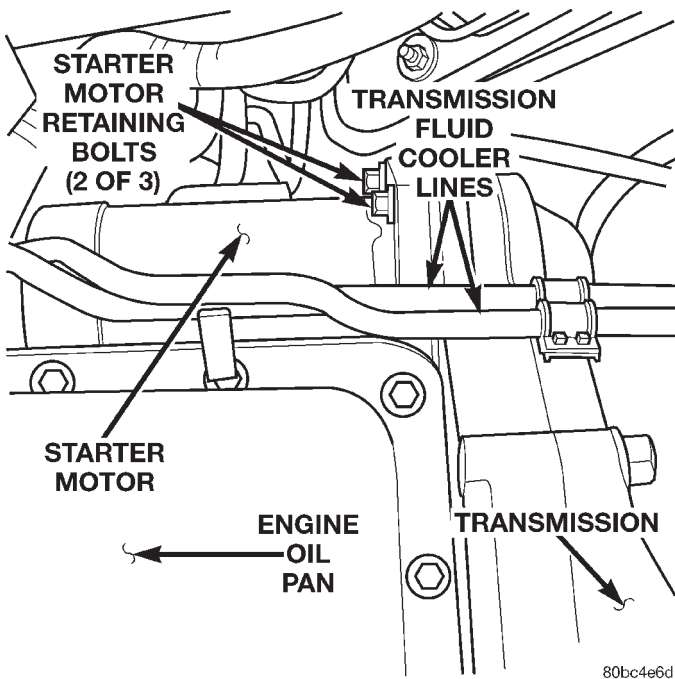

Fig. 15 Starter Motor Position & Orientation

(61) Remove the starter motor retaining bolts and remove the starter from the vehicle (Fig. 15).

NOTE: Mark the position of the torque converter in relation to the driveplate through the starter motor access hole. This reference mark will be used to line up the two components for reassemble.

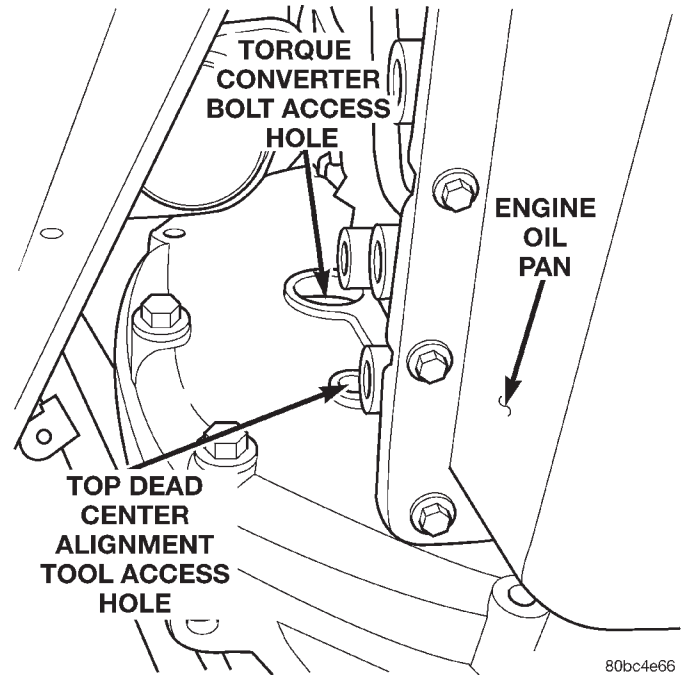

Fig. 16 Torque Converter Bolt Access Hole

(62) Working through the torque converter bolt access hole (Fig. 16), rotate the engine to access and remove the (4) torque converter to driveplate retaining bolts.

(63) Disconnect the engine ground. Located to the rear of the left engine mount.

(64) Remove the left engine mount throughbolt nut. Do not remove the bolt at this time.

(65) Support the rear of the transmission assembly with a jack.

(66) Remove the (8) transmission support crossmember retaining bolts (Fig. 17).

(67) Lower the transmission and transfer case assembly enough to gain access to the upper six transmission bellhousing bolts.

(68) Remove the upper six bellhousing bolts.

(69) Raise the transmission assembly back into position and temporarily install four of the eight transmission crossmember retaining bolts. Install two bolts on each side.

(70) Remove the remaining four bellhousing bolts.

(71) Partially lower the vehicle.

(72) Remove the engine mount sill plate retaining bolts in the left wheel well (Fig. 18).

(73) Remove the engine mount sill plate retaining bolts in the right wheel well (Fig. 19).

(74) lower the vehicle to the ground.

(75) Support the front of the transmission with a jack.

REMOVAL AND INSTALLATION (Continued)

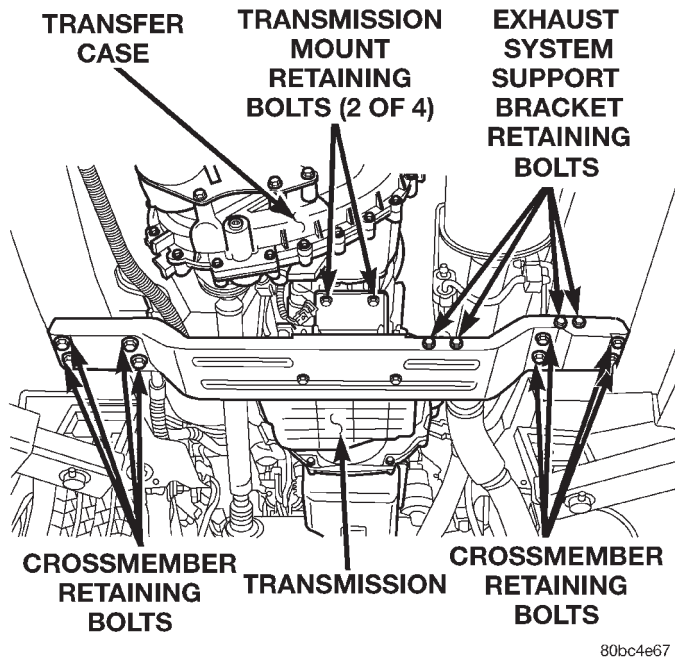

80bc4e67

Fig. 17 Transmission Support Crossmember

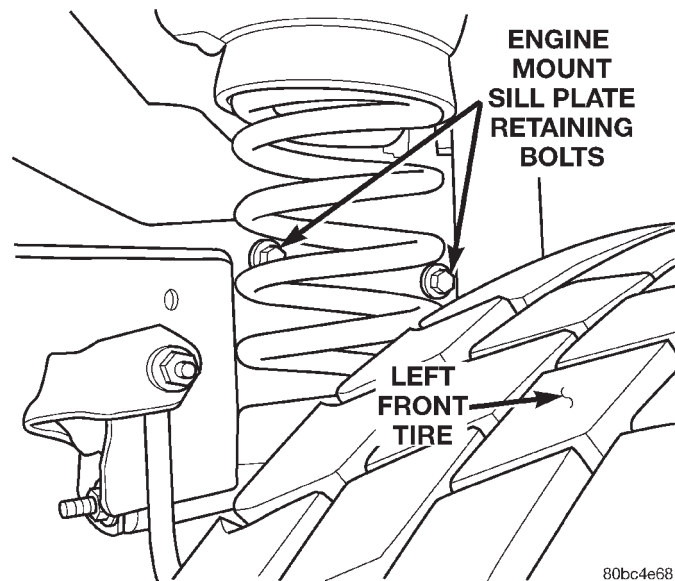

80bc4e68

Fig. 18 Engine Mount Sill Plate Retaining Bolts - Left Wheel Well

(76) Remove the left engine mount sill plate retaining bolts (Fig. 20).

(77) Remove the right engine mount sill plate retaining bolts (Fig. 21).

(78) Set up an engine lifting device and support the weight of the engine assembly.

CAUTION: Before proceeding be certain the front of the transmission is properly supported with a jack.

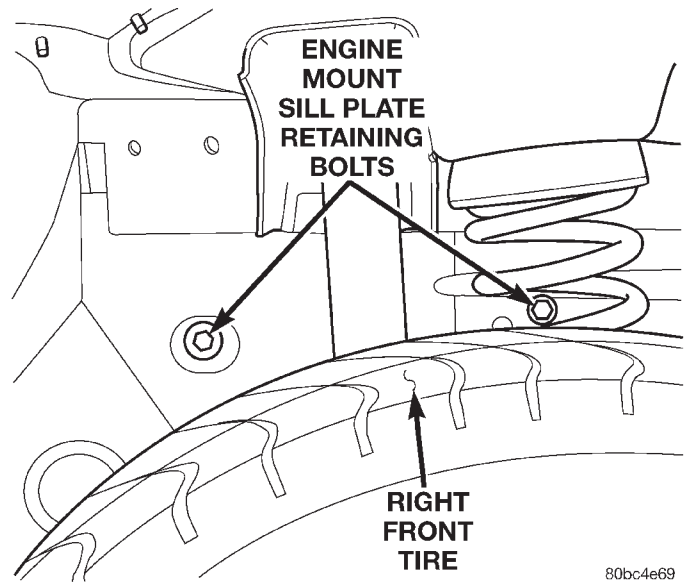

80bc4e69

Fig. 19 Engine Mount Sill Plate Retaining Bolts - Right Wheel Well

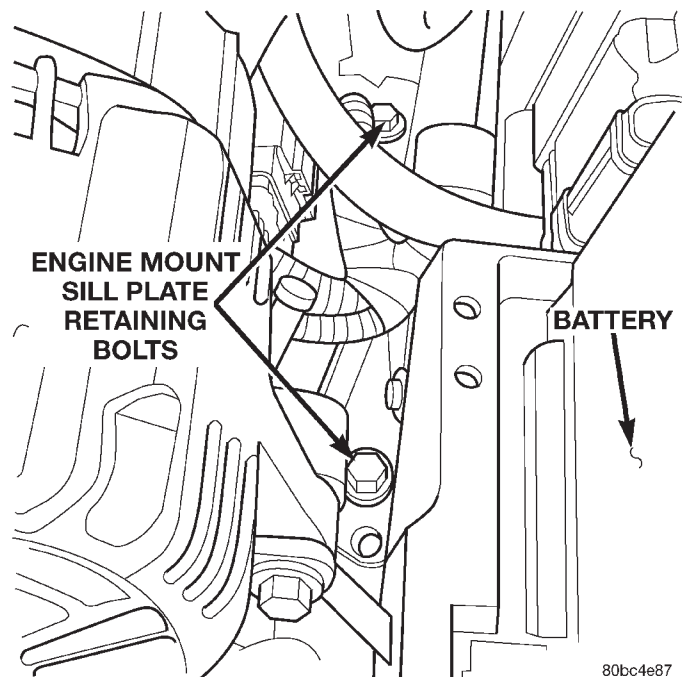

80bc4e87

Fig. 20 Engine Mount Sill Plate Bolts - Leftside

CAUTION: This engine is equipped with a misfire sensor. Located in the top of the bellhousing. Care must be taken not to damage the sensor or corresponding wires during engine removal and installation.

(79) Using the engine lifting device, pull the engine assembly away from the transmission approximately three inches and **stop**.

(80) Working between the bulkhead and the right rear of the engine assembly, disconnect the engine misfire sensor electrical connector.

REMOVAL AND INSTALLATION (Continued)

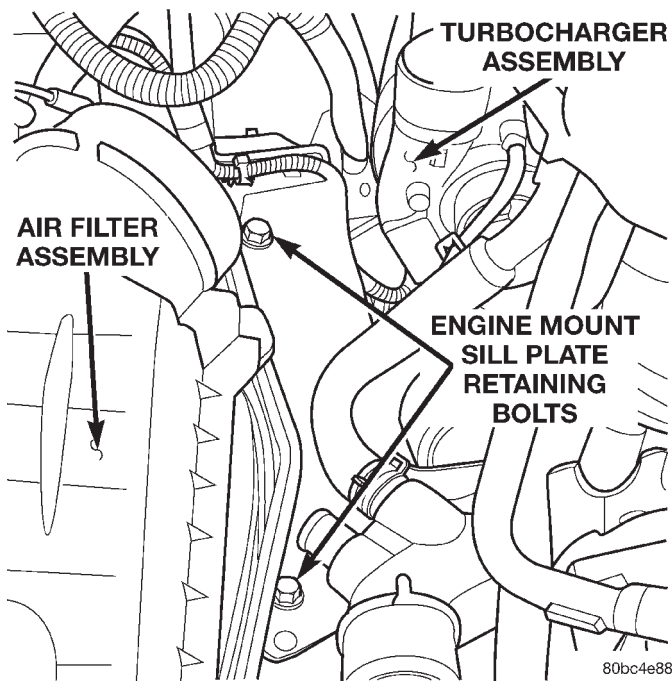

Fig. 21 Engine Mount Sill Plate Bolts - Rightside

- (81) Remove the left engine mount throughbolt.
- (82) Using the engine lifting device, position the engine assembly so the left engine mount sill plate can be removed from the left engine mount.
- (83) With assistance from another person, carefully remove the engine assembly from the vehicle. One person operating the engine lifting device and the other facilitating the engine removal.

INSTALLATION

CAUTION: This engine is equipped with a misfire sensor. Located in the top of the bellhousing. Care must be taken not to damage the sensor or corresponding wires during engine removal and installation.

CAUTION: Be certain the torque converter is properly installed in the transmission. If the torque converter is not installed all the way in the transmission the engine will not rotate upon installation.

- (1) With assistance from another person, carefully install the engine assembly in the vehicle. One person operating the engine lifting device and the other facilitating the engine installation.
- (2) Using the engine lifting device, position the engine assembly so the left engine mount sill plate can be installed around the left engine mount.
- (3) Install the left engine mount throughbolt and nut. Leave loose at this time.

- (4) Working between the bulkhead and the right rear of the engine assembly, connect the engine misfire sensor electrical connector.
- (5) Using the engine lifting device and/or the jack under the transmission, position the engine/transmission assembly so the engine block mounted dowel pins are perfectly aligned with the corresponding holes in the transmission bellhousing.

CAUTION: The engine block and transmission must be in perfect alignment before attempting to install the bellhousing bolts. Misalignment will cause the aluminum bellhousing to be damaged.

- (6) Install two engine to transmission bellhousing retaining bolts. One on each side of the bellhousing.
- (7) Make certain the engine mount sill plate bolt holes are aligned with their corresponding weld nuts in the frame rails.
- (8) Remove the engine lifting device.
- (9) Remove the jack from the transmission.

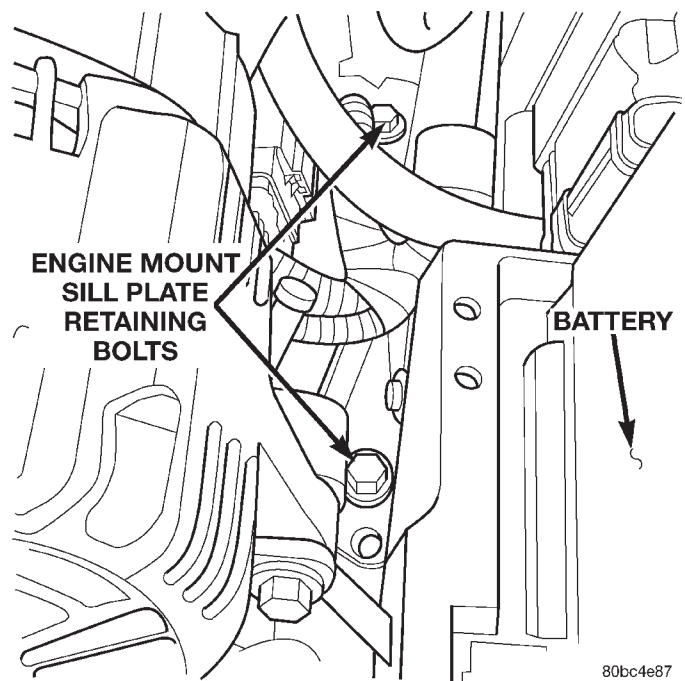

Fig. 22 Engine Mount Sill Plate Bolts - Leftside

- (10) Install the leftside engine mount sill plate retaining bolts (Fig. 22). Leave loose at this time.
- (11) Install the rightside engine mount sill plate retaining bolts (Fig. 23). Leave loose at this time.
- (12) Partially raise the vehicle on the hoist.
- (13) Install the engine mount sill plate retaining bolts in the right wheel well (Fig. 24). Leave loose at this time.
- (14) Install the engine mount sill plate retaining bolts in the left wheel well (Fig. 25). Torque the bolts to 61 N·m (45 ft. lbs.).

REMOVAL AND INSTALLATION (Continued)

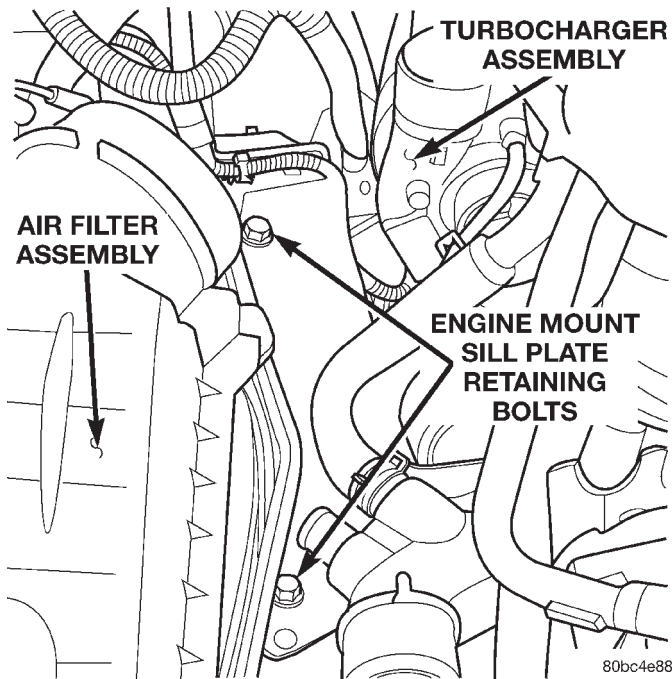

Fig. 23 Engine Mount Sill Plate Bolts - Rightside

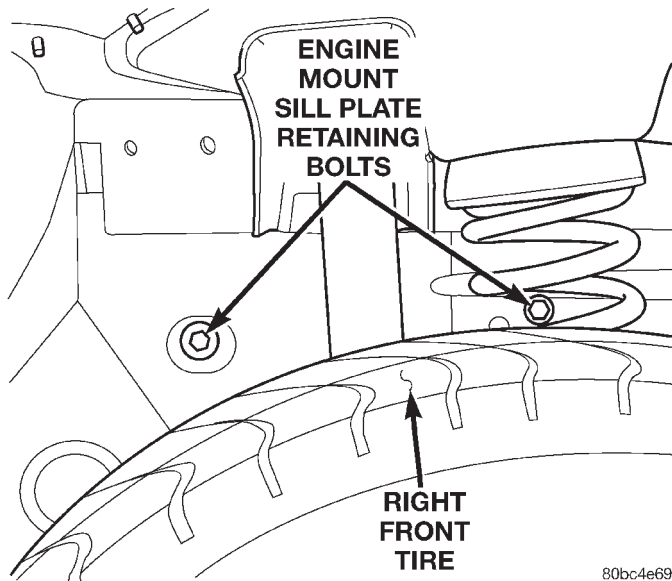

Fig. 24 Engine Mount Sill Plate Bolts - Right Wheel Well

- (15) Torque all engine mount sill plate bolts to 61 N·m (45 ft. lbs.).
- (16) Torque the left engine mount throughbolt to 61 N·m (45 ft. lbs.).
- (17) Raise the vehicle on the hoist.
- (18) Install the remaining lower bellhousing bolts. Torque all the bolts to 102 N·m (75 ft. lbs.).
- (19) Support the rear of the transmission with a jack.
- (20) Remove the (4) temporarily installed transmission crossmember bolts.

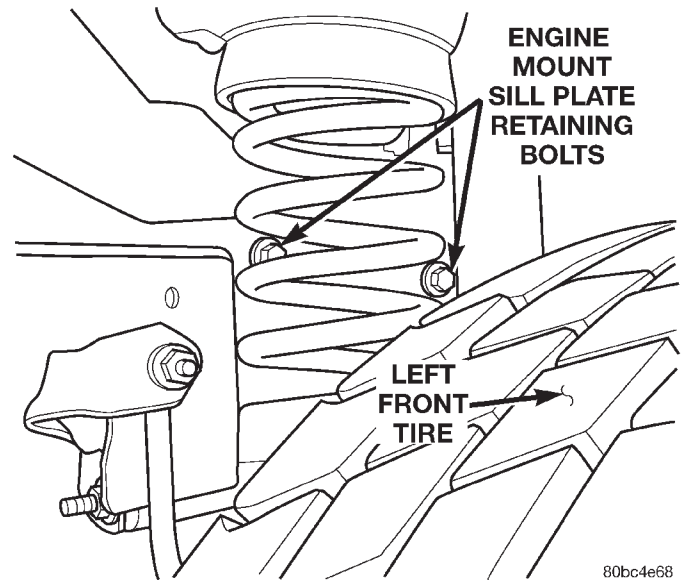

Fig. 25 Engine Mount Sill Plate Bolts - Left Wheel Well

(21) Lower the transmission and transfer case assembly enough to gain access to the upper six bellhousing bolts.

NOTE: Be certain all brackets that were originally installed on the bellhousing bolts are reinstalled. Cable misrouting could result.

(22) Install the upper six bellhousing bolts. Torque the bolts to 102 N·m (75 ft. lbs.).

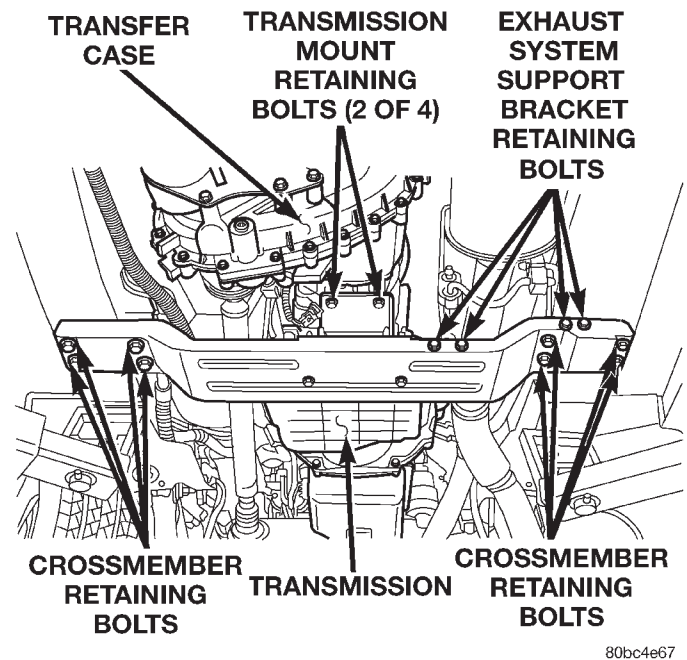

Fig. 26 Transmission Support Crossmember

REMOVAL AND INSTALLATION (Continued)

(23) Raise the transmission assembly back into position and install the eight transmission crossmember retaining bolts (Fig. 26). Torque the bolts to 41 N·m (30 ft. lbs.).

NOTE: Be certain the torque converter is properly aligned with the driveplate before attempting to install the retaining bolts.

NOTE: When installing the torque converter to driveplate retaining bolts, the torque converter can be rotated into position with a flat-bladed screwdriver through the starter motor access hole. Then working through the torque converter bolt access hole, thread a longer than original bolt into the converter and pull the converter up against the driveplate by hand. Remove the longer bolt and install the original bolts one by one until all bolts are installed. Then go back and torque all bolts to specification.

(24) Rotate the engine assembly to access and install the (4) torque converter to driveplate retaining bolts. Torque the bolts to 75 N·m (55 ft. lbs.).

(25) Install the wire harness support bracket on the left engine mount.

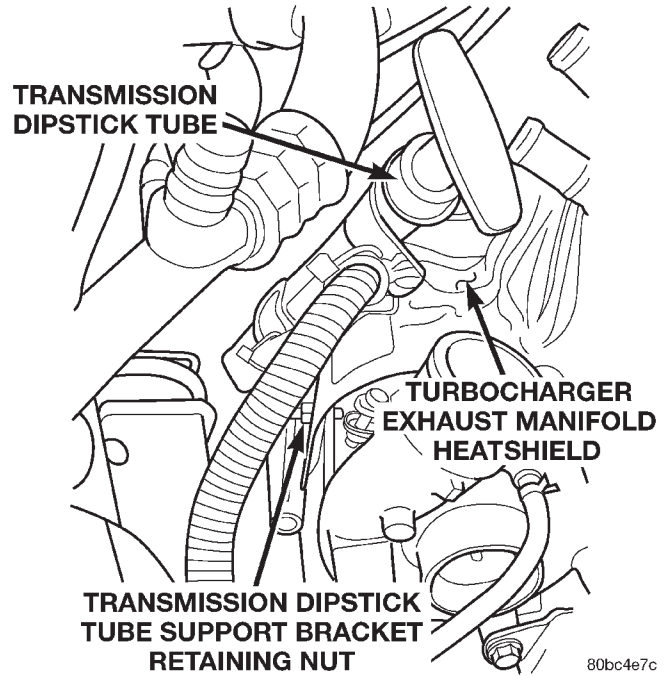

Fig. 28 Transmission Dipstick Tube Support Bracket

(28) Install the transmission dipstick tube support bracket retaining nut on the turbocharger heatshield (Fig. 28). Torque the nut to 25 N·m (221 in. lbs.).

(29) Connect the A/C compressor clutch and glow plug harness electrical connectors.

(30) Connect the black and gray 10-way electrical connectors and clip connectors on the wire harness mounting bracket.

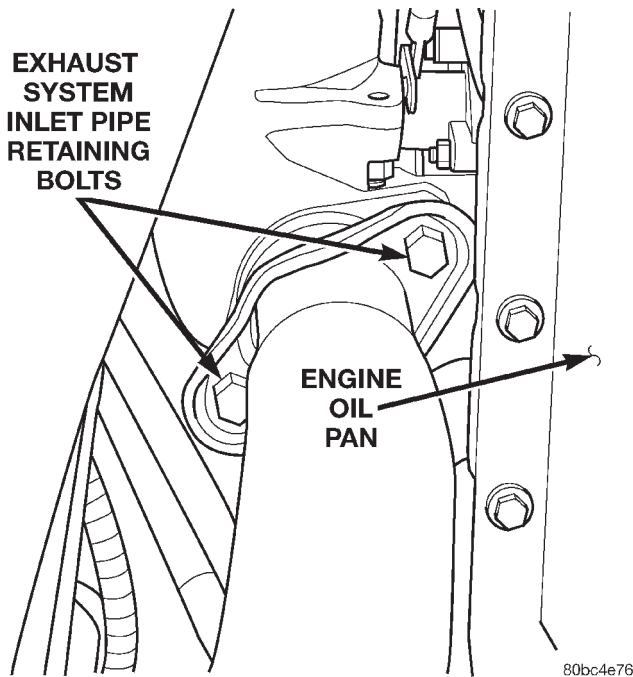

Fig. 27 Exhaust System Inlet Pipe

(26) Install the exhaust system inlet pipe on the turbocharger (Fig. 27). Torque the bolts to 41 N·m (30 ft. lbs.).

(27) Lower the vehicle on the hoist.

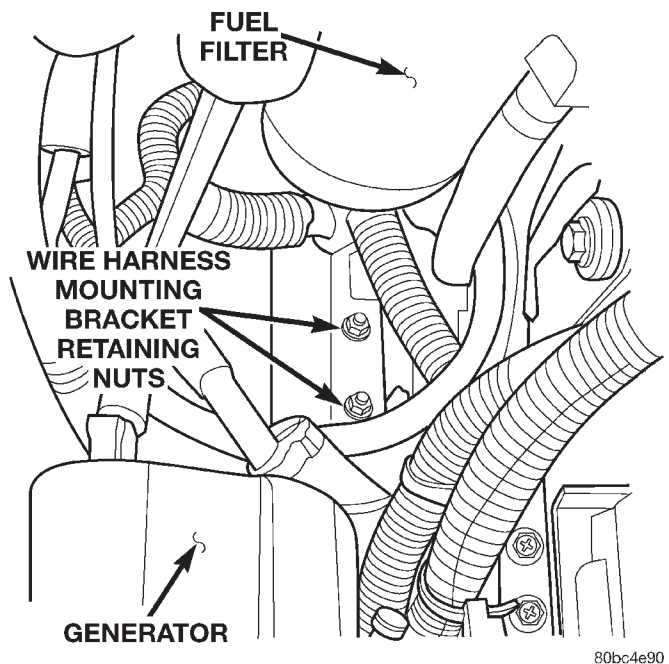

Fig. 29 Wire Harness Mounting Bracket

REMOVAL AND INSTALLATION (Continued)

(31) Install the wire harness mounting bracket and retaining nuts on the left engine mount. Torque the nuts to 25 N·m (221 in. lbs.).

(32) Connect the fuel supply and return hoses on the engine assembly.

(33) Connect the speed control servo vacuum supply hose on the engine mounted steel vacuum source line.

(34) Install the battery feed wire on the top of the generator and install the cover.

(35) Connect the generator field wire connector on the rear of the generator.

(36) Install the vacuum supply hose on the engine mounted steel vacuum source line.

NOTE: When lubricating sealing o-rings or gaskets. Use only the same lubricate that is present in that system.

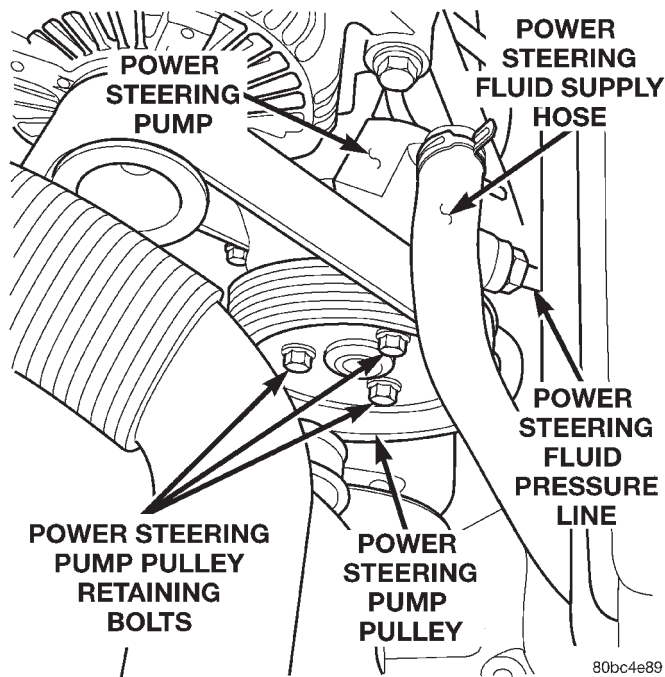

Fig. 30 Power Steering Fluid Lines At Pump

(37) Install the power steering fluid pressure line on the pump (Fig. 30). Be certain the sealing 0-ring is well lubricated and free of tears.

(38) Install the power steering fluid supply hose on the pump (Fig. 30).

(39) Install both of the refrigerant lines on the A/C compressor. Torque the retaining bolts to 28 N·m (21 ft. lbs.). Be certain the sealing gaskets are well lubricated and free of tears.

(40) Install the refrigerant line support bracket and bolt on the cylinder head cover.

(41) Install the tiestraps retaining the wire harness on the low side refrigerant line.

(42) Install the refrigerant liquid line. Torque the retaining nut on the bulkhead to 28 N·m (21 ft. lbs.).

Be certain the sealing gasket is well lubricated and free of tears.

(43) Connect the engine ground. Located just behind the oil filter.

(44) Connect the oil pressure and boost pressure sensor electrical connectors and clip the wire harness on the coolant supply tubes.

(45) Install the low side refrigerant line on the A/C accumulator assembly. Torque the nut to 28 N·m (21 ft. lbs.). Be certain the sealing gasket is well lubricated and free of tears.

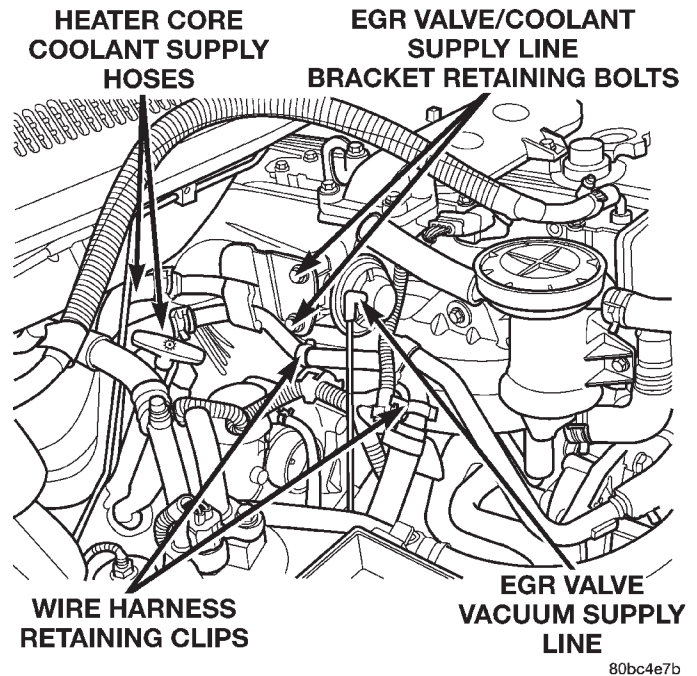

Fig. 31 Engine Compartment View - Rightside

(46) Install the heater core coolant supply hoses on the engine (Fig. 31).

(47) Install the EGR valve vacuum supply line on the valve (Fig. 31).

(48) Install the coolant recovery hose on the water manifold.

(49) Install the coolant reservoir supply hose on the engine.

(50) Install the cooling module assembly and retaining bolts (Fig. 32). Torque the bolts to 41 N·m (30 ft. lbs.).

(51) Install the fan shroud and both cooling fans as an assembly on the vehicle.

(52) Install the suction and discharge refrigerant lines on the condenser assembly (Fig. 32). Torque the retaining nuts to 28 N·m (21 ft. lbs.). Be certain the sealing gaskets are well lubricated and free of tears.

(53) Position the power steering cooler and install the retaining bolts (Fig. 32).

(54) Charge the refrigerant system. Refer to Group 24, Heating and Air Conditioning for the procedure.

REMOVAL AND INSTALLATION (Continued)

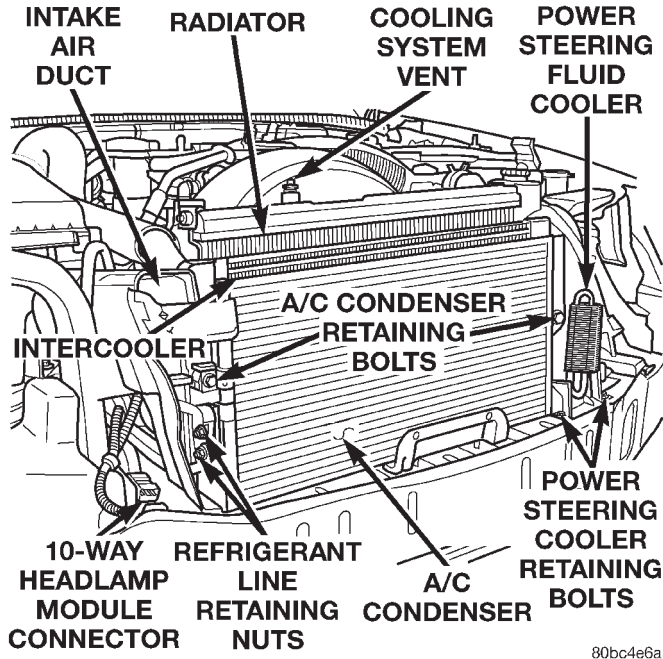

Fig. 32 Cooling Module Assembly

- (55) Connect the electric radiator cooling fan electrical connector.
- (56) Install the intake air duct on the vehicle (Fig. 32).
- (57) Install the upper radiator hose on the vehicle.
- (58) Install the radiator overflow hose on the radiator

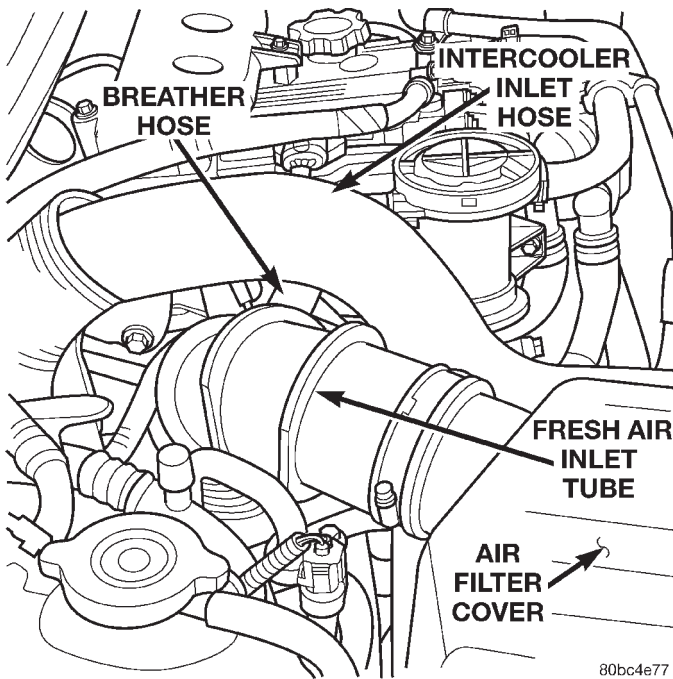

Fig. 33 Air Intake Hoses

- (59) Connect the breather hose and install the fresh air inlet tube on the engine.

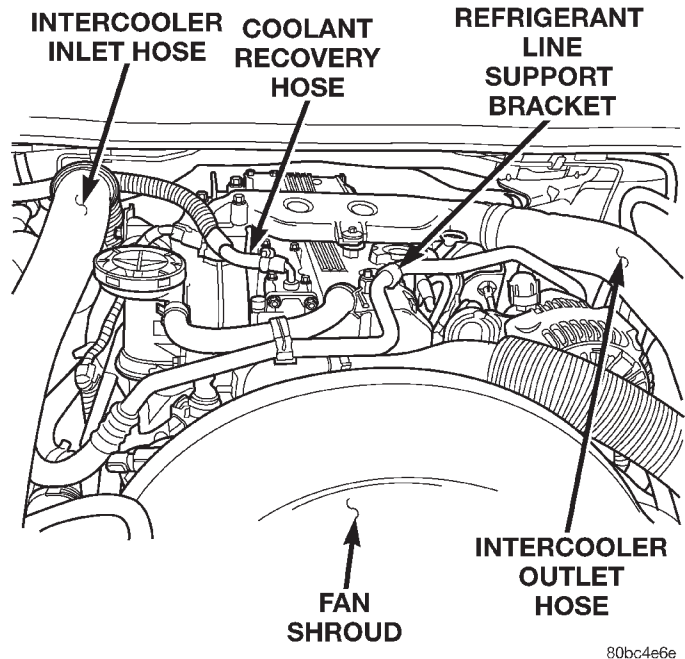
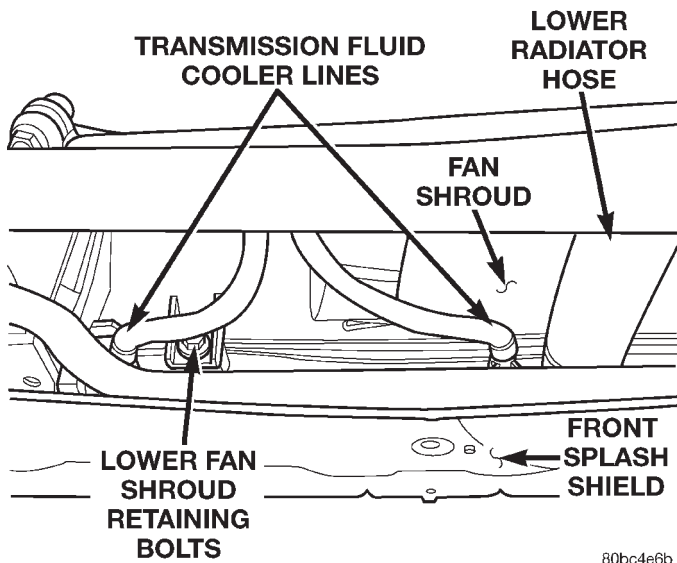

Fig. 34 Intercooler Hoses

- (60) Install the intercooler inlet and outlet hoses on the engine (Fig. 34).
- (61) Install the manual cooling fan on the engine.
- (62) Install the radiator crossmember on the vehicle. Refer to Group 23, Body for the procedure.
- (63) Install the upper fan shroud retaining bolts. Torque the bolts to 15 N·m (132 in. lbs.).
- (64) Install the hood latch support brackets and the hood latch on the vehicle.
- (65) Install the headlamp module mounting (HMM) assembly. Refer to Group 23, Body for the procedure.
- (66) Connect the right and left headlamp module wire harnesses at the 10-way connectors. Located just above the front bumper to the right and left of the a/c condenser.
- (67) Connect the ambient temperature sensor and clip the wire harness on the headlamp module mounting assembly.
- (68) Install the front fascia. Refer to Group 13, Frame and Bumpers for the procedure.
- (69) Install the right and left headlamp assemblies on the vehicle. Refer to Group 8L, Lamps for the procedure.
- (70) Raise the vehicle on the hoist.
- (71) Connect the engine ground. Located to the rear of the left engine mount.
- (72) Install the starter motor. Torque the retaining bolts to 24 N·m (212 in. lbs.).
- (73) Connect the starter motor electrical. Torque the B+ nut to 15 N·m (132 in. lbs.).
- (74) Install the lower fan shroud retaining bolts (Fig. 35). Torque the bolts to 15 N·m (132 in. lbs.).

REMOVAL AND INSTALLATION (Continued)



80bc4e6b

Fig. 35 Transmission Fluid Cooler Lines

(75) Install the lower radiator hose on the radiator (Fig. 35).

(76) Install the transmission fluid cooler lines on the radiator (Fig. 35).

(77) Install both of the front splash shields (Fig. 35).

(78) Lower the vehicle on the hoist.

(79) Fill the cooling system and close the system vent. Refer to Group 7, Cooling System for the procedure.

(80) With assistance from another person, install the hood.

NOTE: Use the previously marked hinge locations for alignment reference.

(81) Install the hood retaining bolts. Torque the bolts to 40 N·m (30 ft. lbs.).

(82) Fill the power steering system fluid. Refer to Group 19, Steering – Power Steering Pump-Initial operation for the procedure.

(83) Fill the transmission fluid. Refer to Group 21, Transmission and Transfer Case for the procedure.

(84) Remove both fender covers.

(85) Connect the engine compartment lamp.

(86) Connect the negative battery cable.

(87) Check the engine oil level before engine start up.

EXHAUST / INTAKE MANIFOLD

REMOVAL

NOTE: The 3.1L Turbo Diesel Engine Exhaust Manifold must be removed first in order to remove the intake manifold. Because these manifolds utilize a single sealing gasket at the cylinder head if either manifold requires service both manifolds must be removed.

- (1) Disconnect the negative battery cable.
- (2) Raise the vehicle on a hoist.

WARNING: DO NOT LOOSEN THE RADIATOR VENT OR DRAINCOCK WITH THE SYSTEM HOT AND PRESSURIZED. SERIOUS BURNS FROM COOLANT CAN OCCUR

- (3) Drain the cooling system. Refer to Group 7, Cooling System for procedure.

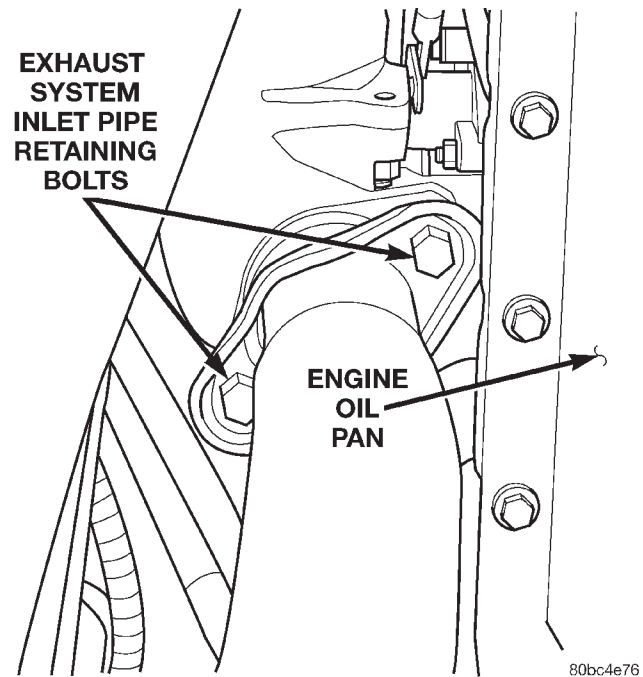

80bc4e76

Fig. 36 Exhaust System Inlet Pipe Retaining Bolts

(4) Remove the exhaust system inlet pipe retaining bolts (Fig. 36).

(5) Disconnect the turbocharger oil return hose from the turbocharger.

(6) Lower the vehicle on the hoist.

(7) Remove the intercooler inlet hose from the vehicle (Fig. 37).

(8) Disconnect the breather hose from the fresh air inlet tube (Fig. 37).

(9) Unclip the air filter cover and remove the fresh air inlet tube from the turbocharger (Fig. 37). Remove the assembly from the vehicle.

(10) Remove the EGR vacuum supply hose from the EGR valve (Fig. 38).

(11) Disconnect the heater core coolant supply lines from the engine assembly (Fig. 38).

(12) Unclip the wire harness from the coolant supply lines (Fig. 38).

(13) Remove the (2) EGR valve / coolant supply line retaining bolts (Fig. 38).

(14) Remove the coolant supply line support bracket bolt from the water pump housing.

REMOVAL AND INSTALLATION (Continued)

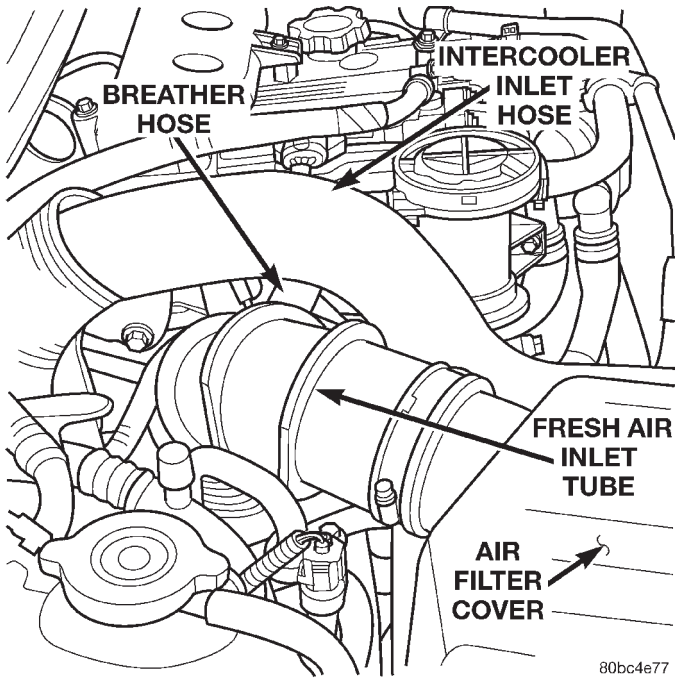

Fig. 37 Air Intake Hoses

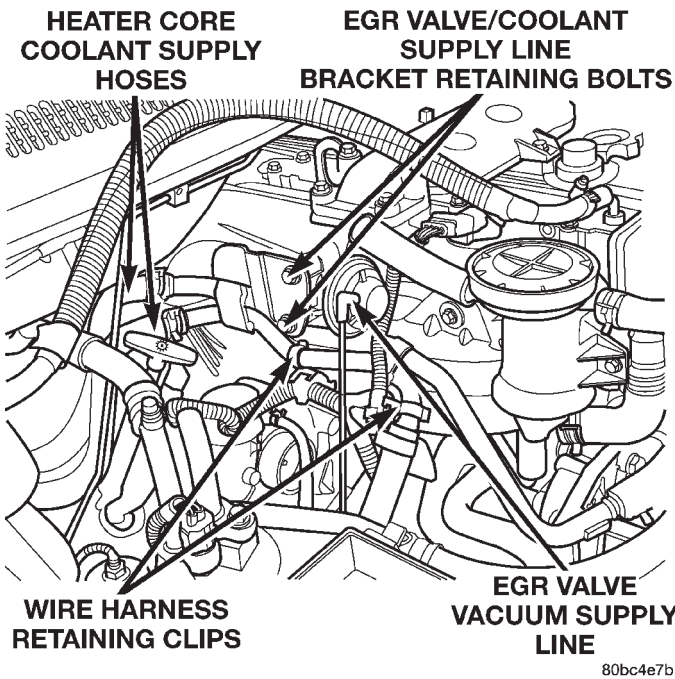

Fig. 38 3.1 L Diesel Engine

- (15) Disconnect the two remaining hoses and remove the coolant lines from the vehicle.
- (16) Remove the oil separator retaining bolts.
- (17) Disconnect the crankcase vapor supply and return hoses and remove the oil separator from the vehicle.
- (18) Remove the transmission dipstick tube support bracket nut from the turbocharger heatshield (Fig. 39).

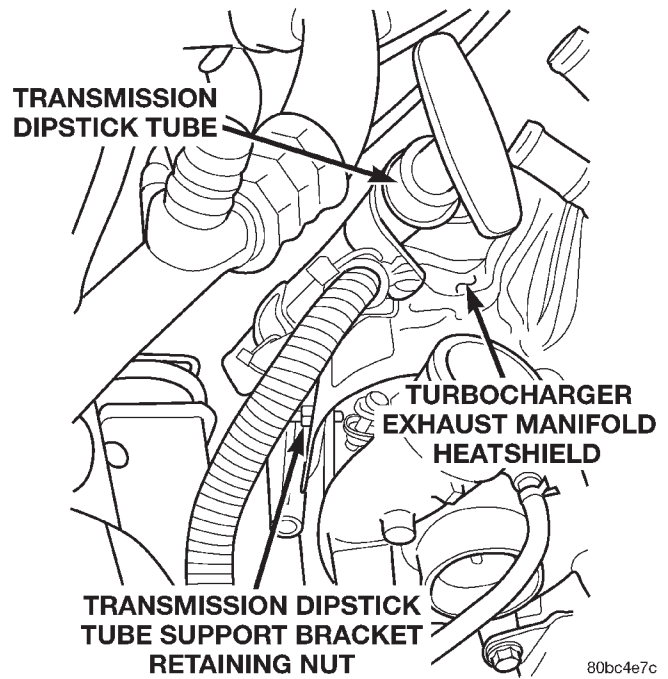

Fig. 39 Transmission Dipstick Tube Support Bracket

WARNING: Heatshield is very sharp. Wear gloves to prevent injury.

- (19) Remove the exhaust manifold / turbocharger heatshield retaining bolts and remove the heatshield from the vehicle.
- (20) Pull back the EGR tube heatshield to access and remove the EGR tube nut from the exhaust manifold. Remove the EGR valve and tube assembly from the vehicle.
- (21) Remove the oil pressure supply line bango bolt from the turbocharger.
- (22) Position a drain pan under the transmission.
- (23) Remove the transmission dipstick tube from the transmission oil pan by pulling straight up. Position the tube assembly out of the way to allow for manifold / turbocharger removal.
- (24) Remove the (10) exhaust manifold retaining nuts and remove the manifold and turbocharger assembly from the vehicle.

NOTE: If only servicing the intake manifold the following two steps are not required.

- (25) Place the assembly in a vice.
- (26) Remove the (4) turbocharger to exhaust manifold retaining nuts and separate.
- (27) Remove the (4) intake air duct retaining bolts from the intake manifold.
- (28) Remove the remaining bolts from the intake air duct and position the duct and hose assembly out of the way.

REMOVAL AND INSTALLATION (Continued)

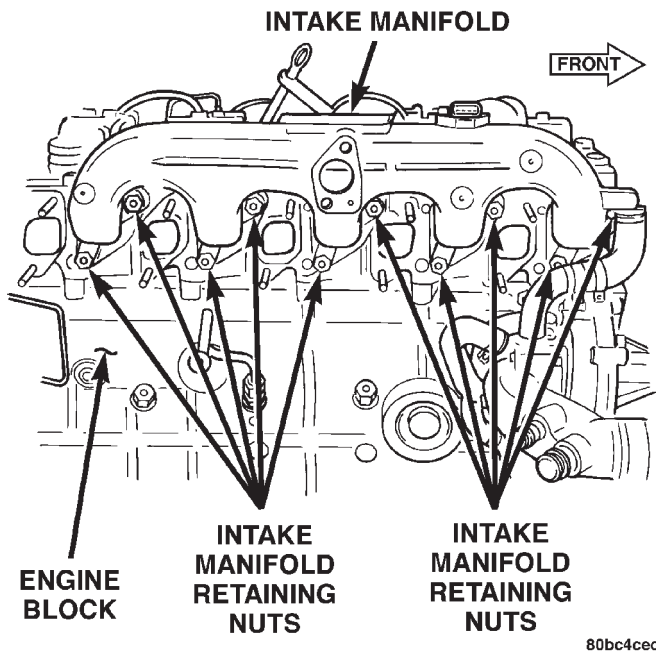

Fig. 40 Intake Manifold Retaining Nuts

(29) Remove the (10) intake manifold retaining bolts and remove the intake manifold from the vehicle (Fig. 40).

(30) Remove the intake/exhaust manifold gasket from the manifolds mounting studs.

CLEANING

All old gaskets should be inspected for any tears or signs of prior leakage. If any gaskets show such indications, they should be replaced with new gaskets. All gasket mating surfaces must be cleaned of old gasket material to produce a smooth and dirt/oil free sealing surface for the new gasket.

INSTALLATION

(1) Position the new intake/exhaust manifold gasket on the manifolds mounting studs.

(2) Install the intake manifold and install the (10) retaining nuts (Fig. 40). Torque the nuts to 32 N·m (23 ft. lbs.).

(3) Position the new intake air duct gasket.

(4) Install the intake air duct on the engine. Torque the bolts to 32 N·m (23 ft. lbs.).

NOTE: If only servicing the intake manifold the following two steps are not required.

(5) Position the gasket and install the turbo on the exhaust manifold. Torque the nuts to 32 N·m (23 ft. lbs.) (Fig. 41).

(6) Remove the assembly from the vice and position on the exhaust manifold mounting studs.

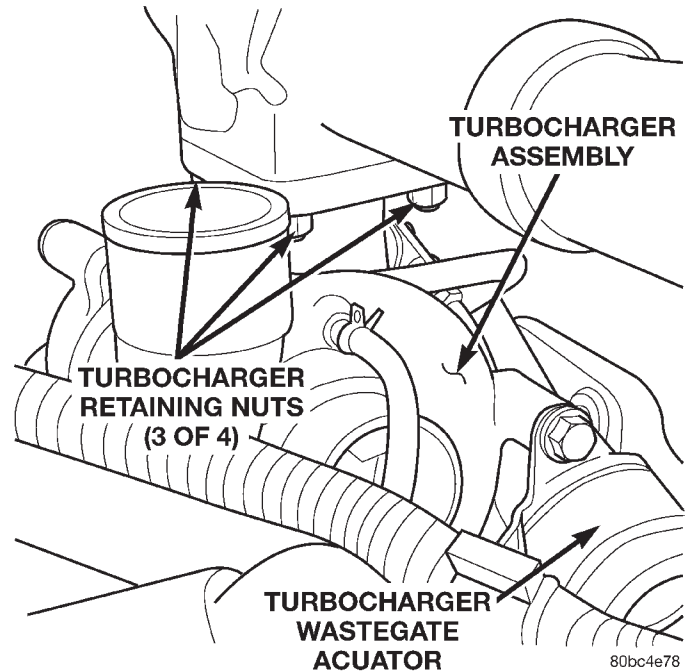

Fig. 41 Turbocharger Retaining Nuts

(7) Install the exhaust manifold retaining nuts and torque to 32 N·m (23 ft. lbs.).

(8) Install the transmission dipstick tube in the transmission case.

(9) Remove the drain pan.

(10) Install the oil pressure supply line on turbocharger. Torque bango bolt fitting to 27 N·m (20 ft. lbs.). Be certain the copper sealing washers are installed. One on the top and bottom of the supply line.

(11) Install the EGR tube nut on the exhaust manifold and temporarily install one of the EGR valve retaining bolts. Be certain the EGR valve gasket is in place.

(12) Torque the EGR tube retaining nut to 34 N·m (25 ft. lbs.). Remove the temporarily installed EGR valve bolt

WARNING: Heatshield is very sharp. Wear gloves to prevent injury.

(13) Install the exhaust manifold heatshield. Torque bolts to 11 N·m (97 in. lbs.).

(14) Install the transmission dipstick tube support bracket retaining nut on the turbocharger heatshield (Fig. 42). Torque the nut to 20 N·m (177 in. lbs.).

(15) Install the front (front of engine) heater core coolant supply hoses on the coolant line assembly and install the line assembly on the engine. Torque the (3) retaining bolts to 27 N·m (20 ft. lbs.) (Fig. 43).

(16) Connect the crankcase vapor supply and return hoses on the oil separator.

(17) Install the oil separator retaining bolts.

REMOVAL AND INSTALLATION (Continued)

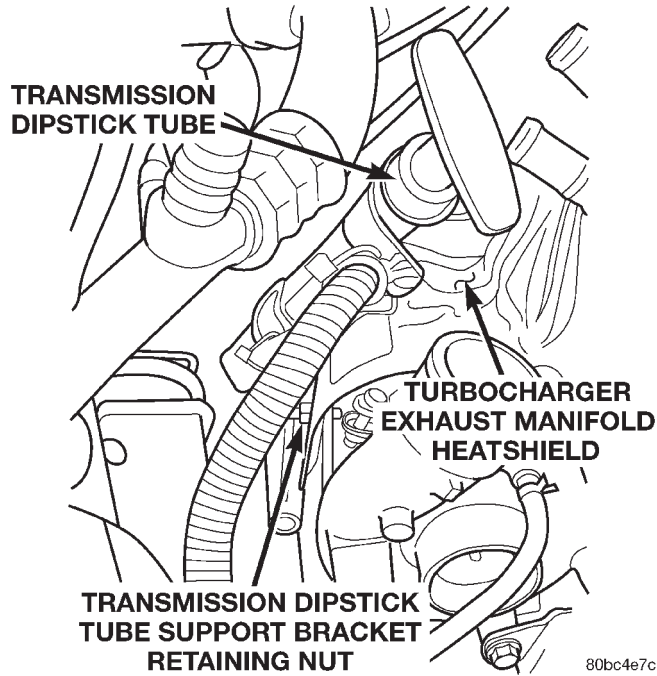

Fig. 42 Transmission Dipstick Tube Support Bracket

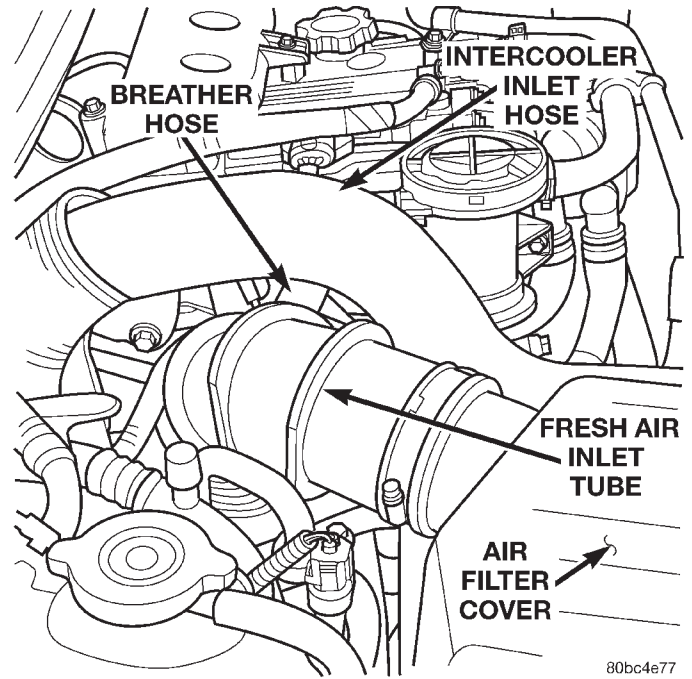

Fig. 44 Air Intake Hoses

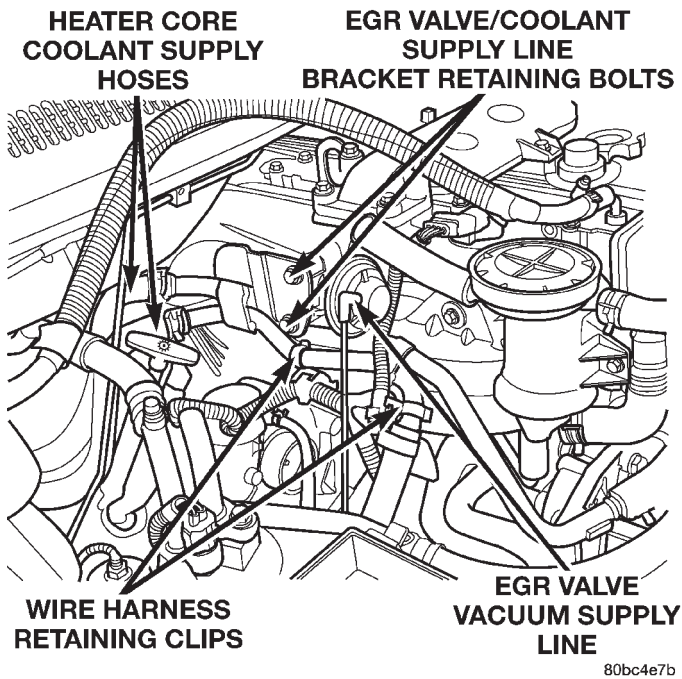

Fig. 43 3.1L Diesel Engine

- (18) Install the heater core coolant supply hoses on the coolant line assembly (Fig. 43).
- (19) Clip the wire harness on the coolant supply lines (Fig. 43).
- (20) Install the EGR vacuum supply hose on the EGR valve.
- (21) Install the fresh air inlet tube assembly on the turbocharger. Clip the air filter cover in position and connect the breather hose (Fig. 44).

- (22) Install the intercooler inlet hose on the vehicle (Fig. 44).
- (23) Raise the vehicle on the hoist.
- (24) Install the turbocharger oil return hose on the turbocharger.

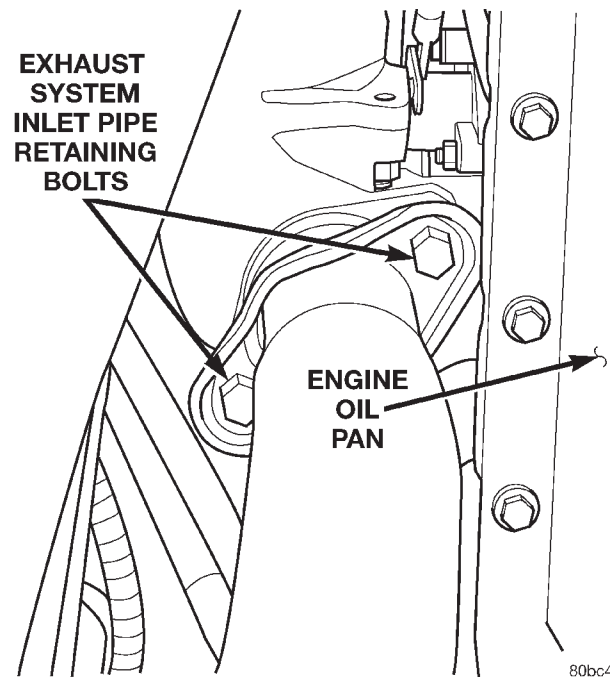

Fig. 45 Exhaust System Inlet Pipe Retaining Bolts

- (25) Install the exhaust system inlet pipe on the turbocharger (Fig. 45). Torque the bolts to 22 N-m (194 in. lbs.).
- (26) Lower the vehicle on the hoist.

REMOVAL AND INSTALLATION (Continued)

(27) Fill the cooling system. Refer to Group 7, Cooling System for procedure.

(28) Check the transmission fluid level and top off if necessary.

(29) Connect the negative battery cable.

(30) Start the engine and check for leaks.

CYLINDER HEAD COVER

REMOVAL

(1) Disconnect the negative battery cable.

(2) Recover the refrigerant system. Refer to Group 24, Heating and Air Conditioning for the procedure.

(3) Raise the vehicle on the hoist.

(4) Remove the front splash shield.

(5) Remove the low pressure refrigerant line retaining bolt and remove the line from the compressor. Cover both openings.

(6) Remove the left engine mount throughbolt nut. Do not remove the bolt at this time.

(7) Lower the vehicle on the hoist.

(8) Remove the intake manifold elbow inlet hose (Fig. 46).

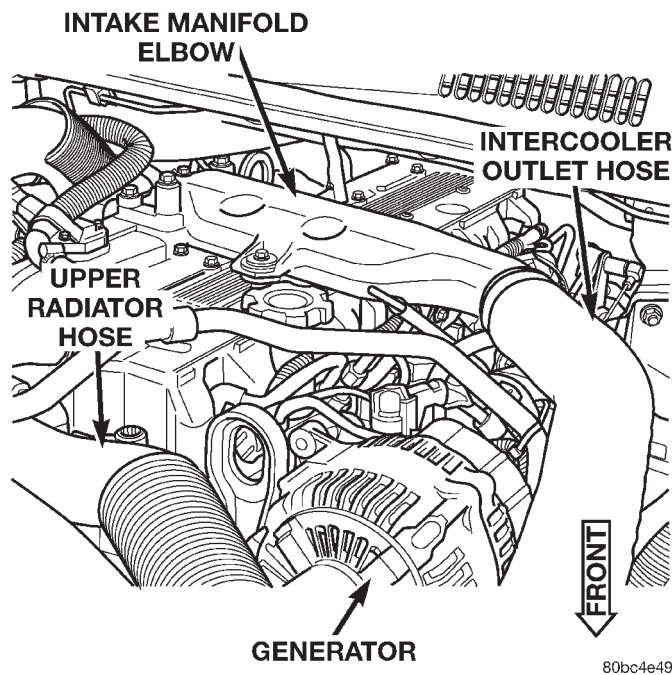

Fig. 46 Intake Manifold Elbow

(9) Remove the intake manifold elbow (Fig. 46).

(10) Remove the refrigerant line support bracket retaining bolt from the cylinder head cover and position the refrigerant line out of the way.

(11) Disconnect the (5) glow plug electrical connectors and position the wire harness out of the way.

(12) Remove the Crankcase breather hose from the front of the cylinder head cover.

(13) Remove the cylinder head cover retaining bolts (Fig. 47).

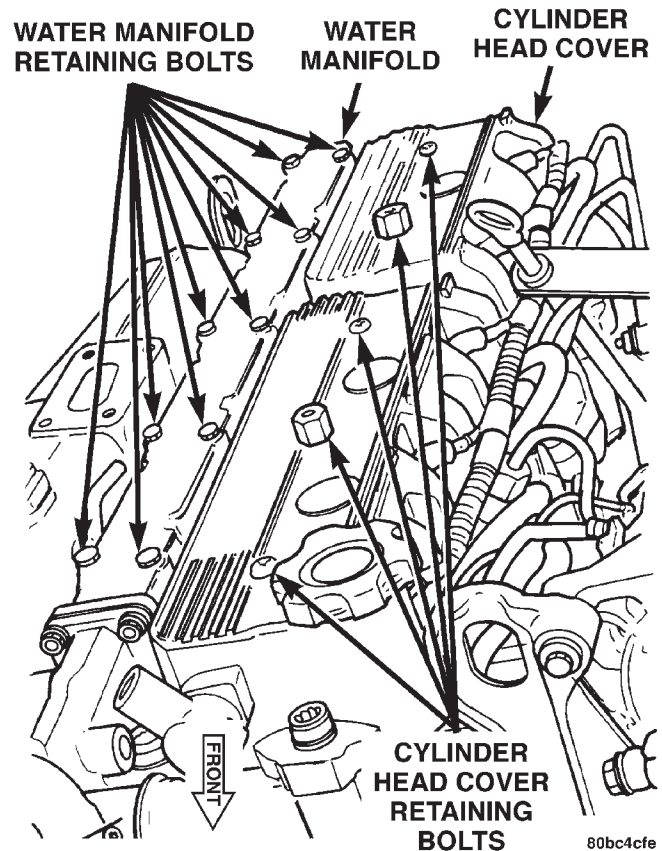

Fig. 47 Cylinder Head Cover

(14) Remove the fuel filter / water separator retaining nuts and position the filter assembly out of the way.

(15) Position a jack under the oil pan. Make sure to place a piece of wood between the jack and the oil pan.

(16) **Slightly**, raise the weight off of the left engine mount until the left engine mount throughbolt can be removed.

(17) Using the jack, lower the engine assembly until the cylinder head cover can be removed from the vehicle.

INSTALLATION

(1) Install the cylinder head cover and gasket. Torque the bolts to 15 N·m (133 in. lbs.) (Fig. 48).

(2) Using the jack, raise the engine assembly until the left engine mount throughbolt can be installed.

(3) Remove the jack and install the fuel filter / water separator.

(4) Connect the crankcase breather hose to front of cylinder head cover.

(5) Connect the (5) glow plug electrical connectors (Fig. 48).

(6) Position the refrigerant line and install the retaining bolt.

(7) Install the intake manifold elbow (Fig. 49).

REMOVAL AND INSTALLATION (Continued)

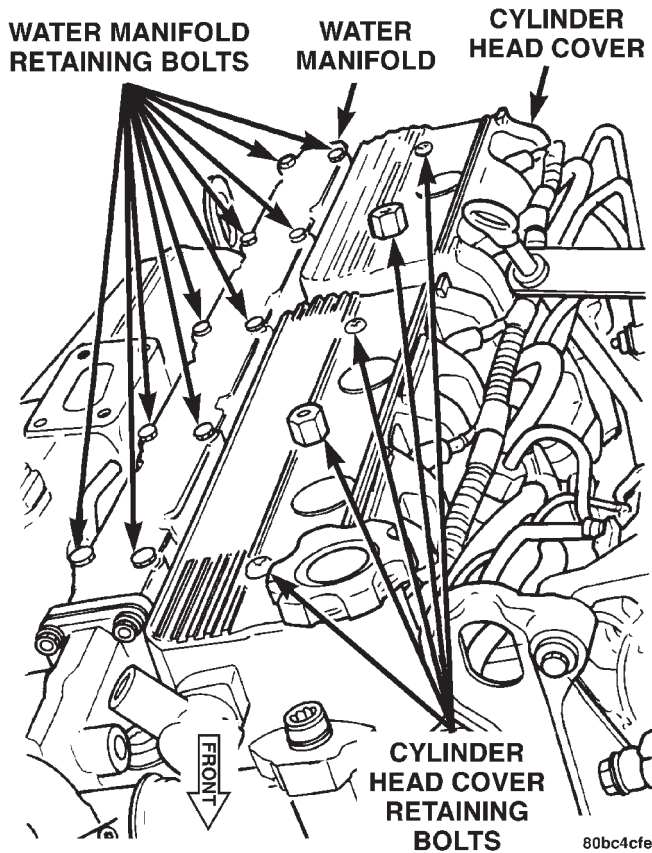

Fig. 48 Cylinder Head Cover

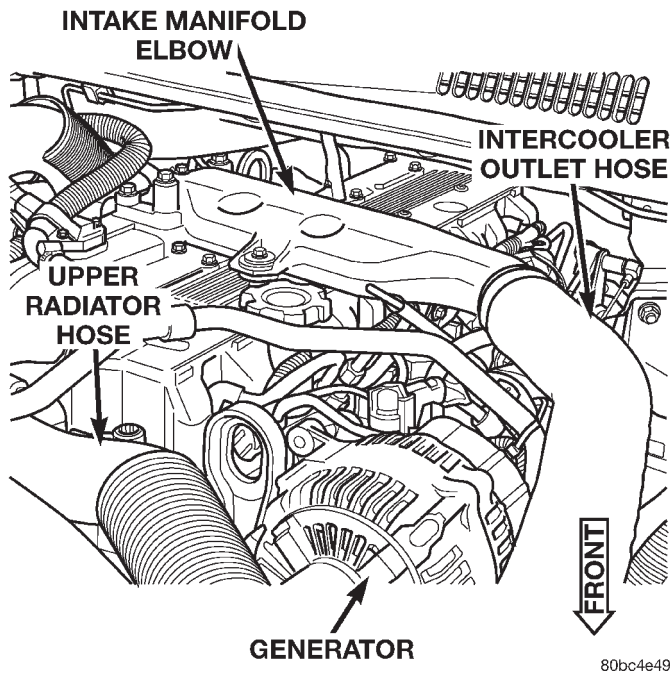

Fig. 49 Intake Manifold Elbow

- (8) Install the intake manifold elbow inlet hose (Fig. 49).
- (9) Raise the vehicle on the hoist.

- (10) Install the left engine mount throughbolt nut. Torque the nut to 61 N·m (45 ft. lbs.).
- (11) Install the low pressure refrigerant line and retaining bolt. Torque the bolt to 28 N·m (21 ft. lbs.). Be certain the sealing o-ring is well lubricated and free of tears.
- (12) Install the front splash shield.
- (13) Lower the vehicle on the hoist.
- (14) Connect the negative battery cable.
- (15) Evacuate and charge the refrigerant system. Refer to Group 24, Heater and Air Conditioning for the procedure.
- (16) Start the engine and check for leaks.

WARNING: USE EXTREME CAUTION WHEN THE ENGINE IS OPERATING. DO NOT STAND IN DIRECT LINE WITH THE FAN. DO NOT PUT HANDS NEAR THE PULLEYS, BELTS OR FAN. DO NOT WEAR LOOSE CLOTHING.

HYDRAULIC TAPPETS

REMOVAL

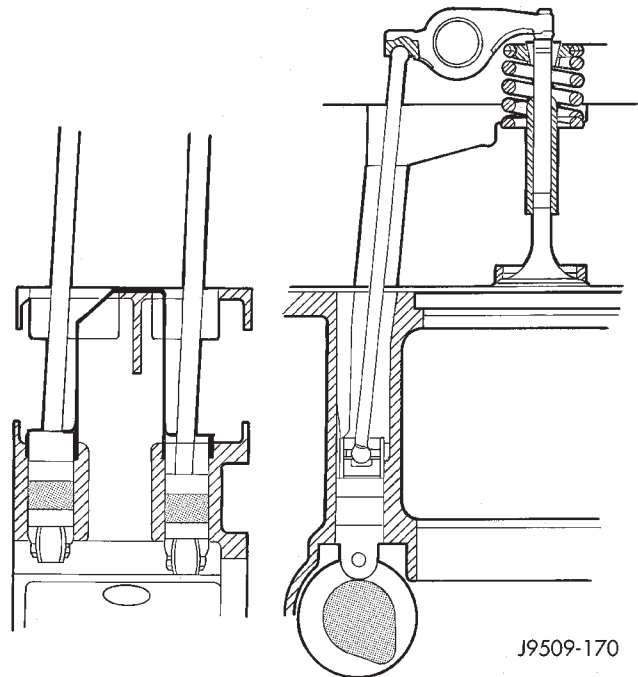

Fig. 50 Tappet And Rocker Arm Assembly

- (1) Disconnect the negative battery cable.
- (2) Discharge the air conditioning system. Refer to Group 24, Heating and Air Conditioning for procedure.
- (3) Remove the A/C lines at the compressor and cap.
- (4) Remove the A/C line bracket attached to the cylinder head cover and move the lines away from the cylinder head.

REMOVAL AND INSTALLATION (Continued)

(5) Remove cylinder head cover. Refer to cylinder head cover removal and installation procedure in this section.

(6) Remove the rocker assemblies and push rods. Refer to rocker arms and push rod removal and installation procedure in this section. Identify push rods to ensure installation in original location.

(7) Remove cylinder head, intake manifold, and exhaust manifold. Refer to cylinder head removal and installation in this section.

(8) Remove the tappet retainers (Fig. 51).

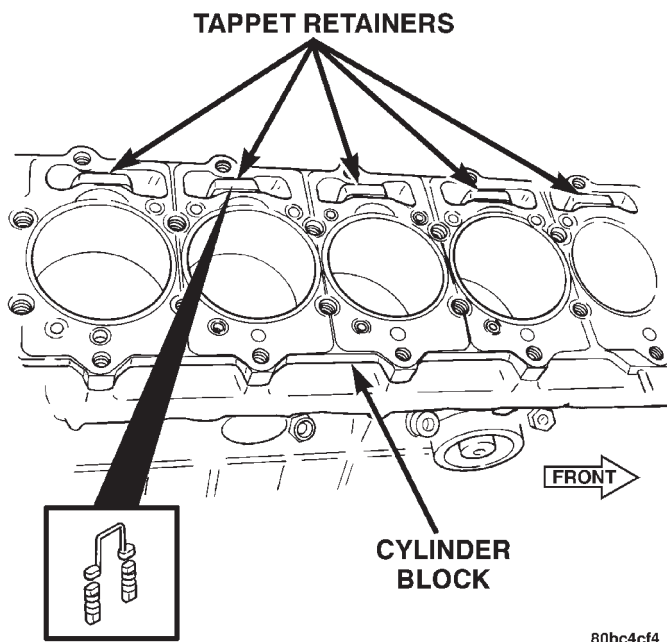

80bc4cf4

Fig. 51 Tappet And Retainer

(9) Slide Hydraulic Tappet Remover/Installer Tool through opening in block and seat tool firmly in the head of tappet.

(10) Pull the tappet out of the bore with a twisting motion. If all tappets are to be removed, identify tappets to ensure installation in original location.

CAUTION: The plunger and tappet bodies are not interchangeable. The plunger and valve must always be fitted to the original body. It is advisable to work on one tappet at a time to avoid mixing of parts. Mixed parts are not compatible. **DO NOT** disassemble a tappet on a dirty work bench.

INSTALLATION

(1) Lubricate the tappets.

(2) Install the tappets and retainers in their original positions. Ensure that the oil feed hole in the side of the tappet body faces up (away from the crankshaft).

(3) Install the cylinder head, intake manifold, and exhaust manifold. Refer to cylinder head removal and installation in this section.

(4) Install the push rods.

(5) Install the rocker arms. Refer to rocker arms and push rod removal and installation in this section.

(6) Install the cylinder head cover. Refer to cylinder head cover removal and installation in this section.

(7) Connect the negative battery cable.

CAUTION: To prevent damage to valve mechanism, engine must not be run above fast idle until all hydraulic tappets have filled with oil and have become quiet.

(8) Start and operate engine. Warm up to normal operating temperature.

ROCKER ARMS AND PUSH RODS

REMOVAL

(1) Disconnect the negative battery cable.

(2) Discharge the air conditioning system. Refer to Group 24, Heating and Air Conditioning for procedure.

(3) Remove the service valves and cap the compressor ports. Refer to Group 24, Heating and Air Conditioning.

(4) Remove the cylinder head cover. Refer to cylinder head cover removal and installation in this section.

(5) Remove the rocker arm retaining nut (Fig. 52) (Fig. 53).

(6) Remove the rocker assembly. Place them on a bench in the same order as removed.

(7) Remove the push rods and place them on a bench in the same order as removed.

INSTALLATION

(1) Rotate the crankshaft until the mark lines up with the TDC mark on the timing cover.

(2) Install the push rods in the same order as removed.

WARNING: During the installation of the rocker arm assemblies it is possible to cause valve interference between the piston and valve if the piston is near Top Dead Center (TDC). This is due to the slow bleed down rate of the tappets when adjusting the rocker arm assemblies. Follow the procedure below to ensure that engine damage does not occur.

- Install the rocker arm assemblies in the same order as removed.

- Bring piston # 1 to Top Dead Center.

REMOVAL AND INSTALLATION (Continued)

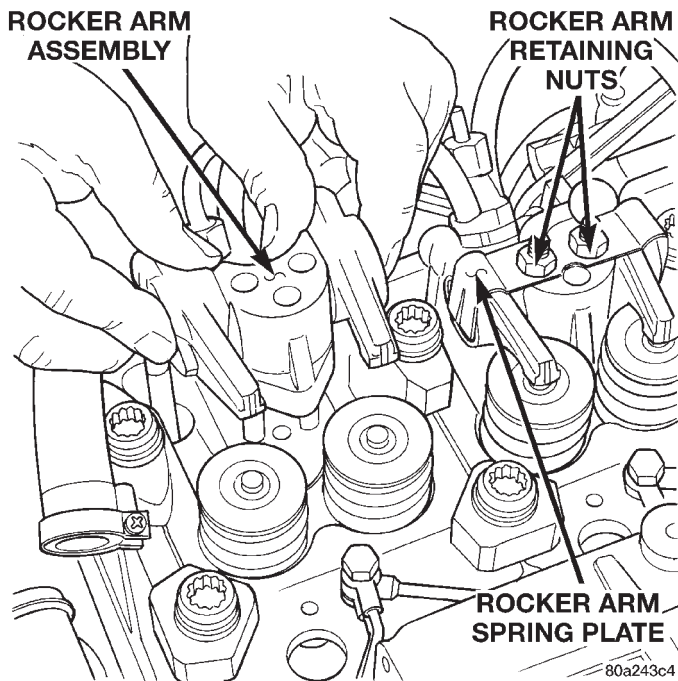

Fig. 52 Rocker Arm Retaining Nut

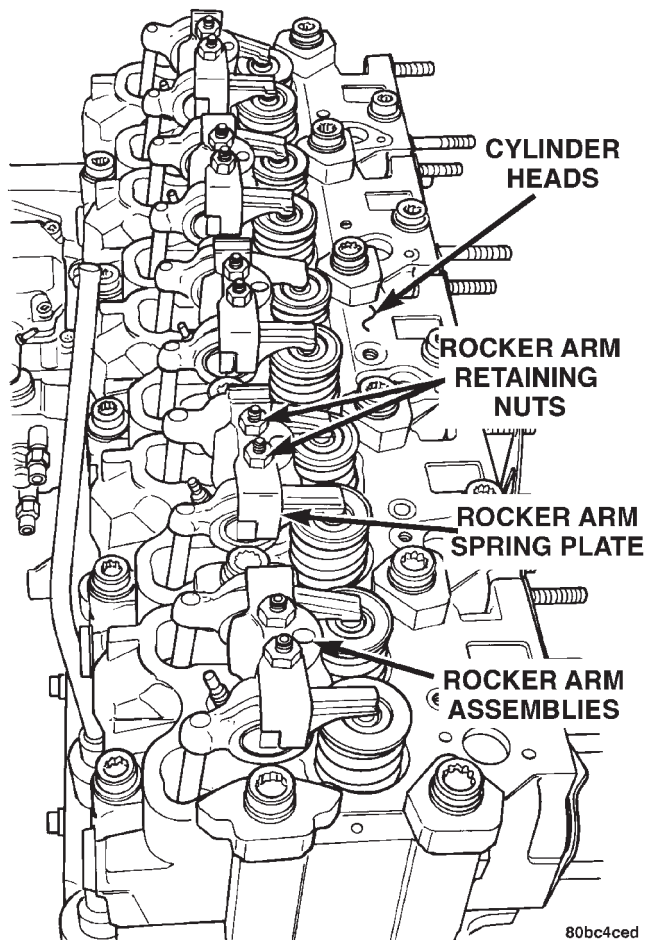

Fig. 53 Rocker Arm Assemblies

- At this point tighten the rocker arm nuts for cylinder # 2-3-4-5. Torque nuts to 27 N·m (20 ft. lbs.).
 - Slowly rotate the crankshaft 90° clockwise or counterclockwise, then tighten the rocker arm nuts for cylinder # 1. Torque nuts to 27 N·m (20 ft. lbs.).
- (4) Install the cylinder head cover. Refer to cylinder head cover removal and installation in this group.
 - (5) Evacuate and charge the air conditioning system. Refer to Group 24, Heater and Air Conditioning.
 - (6) Connect the negative battery cable.

VALVE SPRINGS

This procedure can be done with the engine cylinder head installed on the block. Each valve spring is held in place by a retainer and a set of conical valve locks. The locks can be removed only by compressing the valve spring.

REMOVAL

- (1) Disconnect the negative battery cable.
- (2) Remove the cylinder head cover. Refer to cylinder head cover removal and installation in this section.
- (3) Remove the rocker arms assemblies and push rods. Refer to rocker arm and push rod removal and installation in this section. Retain the push rods, and rocker arms assemblies in the same order and position as removed.
- (4) Inspect the springs and retainer for cracks and possible signs of weakening.
- (5) Install an air hose adaptor in the fuel injector hole.
- (6) Connect an air hose to the adapter and apply air pressure slowly. Maintain at least 621 kPa (90 psi) of air pressure in the cylinder to hold the valves against their seats.
- (7) Tap the retainer or tip with a rawhide hammer to loosen the lock from the retainer. Use Valve Spring Compressor Tool to compress the spring and remove the locks.
- (8) Remove the valve spring and retainer.
- (9) Inspect the valve stems, especially the grooves. An Arkansas smooth stone should be used to remove nicks and high spots.

INSTALLATION

- (1) Install the valve spring and retainer.
- (2) Compress the valve spring with Valve Spring Compressor Tool and insert the valve locks. Release the spring tension and remove the tool. Tap the spring from side-to-side to ensure that the spring is seated properly on the engine cylinder head.
- (3) Disconnect the air hose. Remove the adaptor from the fuel injector hole and install the fuel injector.

REMOVAL AND INSTALLATION (Continued)

(4) Repeat the procedures for each remaining valve spring to be removed.

(5) Install the push rods. Ensure the bottom end of each rod is centered in the plunger cap seat of the hydraulic valve tappet.

WARNING: During the installation of the rocker arm assemblies it is possible to cause valve interference between the piston and valve if the piston is near Top Dead Center (TDC). This is due to the slow bleed down rate of the tappets when adjusting the rocker arm assemblies. Follow the procedure below to ensure that engine damage does not occur.

- Install the rocker arm assemblies in the same order as removed.
- Bring piston # 1 to Top Dead Center.
- At this point tighten the rocker arm nuts for cylinder # 2-3-4-5. Torque nuts to 27 N·m (20 ft. lbs.).
- Slowly rotate the crankshaft 90° clockwise or counterclockwise, then tighten the rocker arm nuts for cylinder # 1. Torque nuts to 27 N·m (20 ft. lbs.).

(7) Install the cylinder head cover. Refer to cylinder head cover removal and installation in this section.

(8) Connect the negative battery cable.

ENGINE CYLINDER HEAD

REMOVAL

(1) Disconnect the negative battery cable.

WARNING: DO NOT REMOVE THE CYLINDER BLOCK DRAIN PLUGS OR LOOSEN THE RADIATOR DRAIN COCK WITH THE SYSTEM HOT AND PRESSURIZED BECAUSE SERIOUS BURNS FROM THE COOLANT CAN OCCUR.

(2) Drain the cooling system. Refer to Group 7, Cooling System for procedure.

(3) Discharge the air conditioning system. Refer to Group 24, Heating and Air Conditioning for procedure.

(4) Remove the A/C lines at the compressor and cap. Refer to Group 24, Heating and Air Conditioning.

(5) Remove A/C line bracket attached to cylinder head cover, and move A/C lines away from cylinder head.

(6) Remove the intake manifold elbow air inlet hose (Fig. 54).

(7) Remove the intake manifold elbow (Fig. 54).

(8) Remove the air cleaner hose from turbocharger and breather hose.

(9) Remove the upper radiator hose and coolant recovery hose.

(10) Remove the water manifold (Fig. 55).

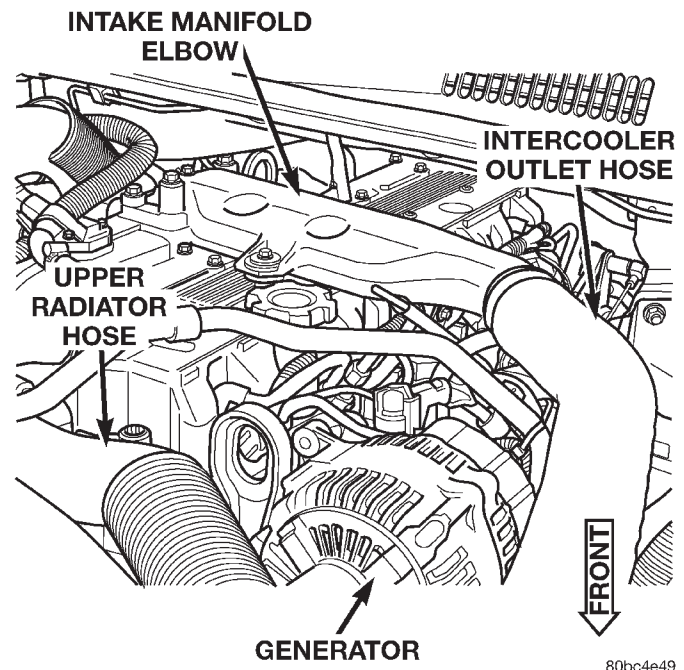

Fig. 54 Intake Manifold Elbow

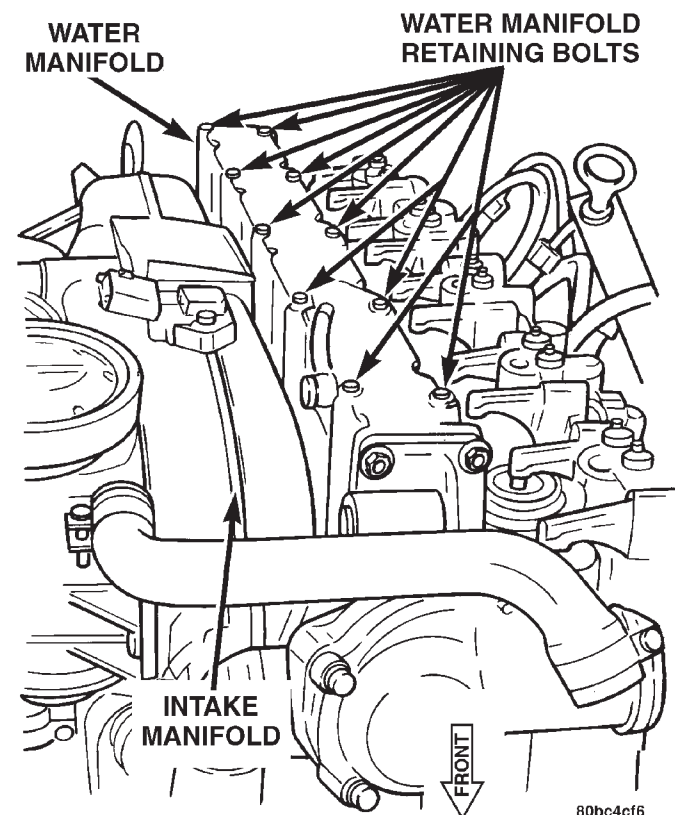

Fig. 55 Water Manifold

(11) Disconnect the heater hoses (Fig. 56).

(12) Remove the EGR valve/heater core supply line retaining bolts

(13) Remove the heater core supply lines

REMOVAL AND INSTALLATION (Continued)

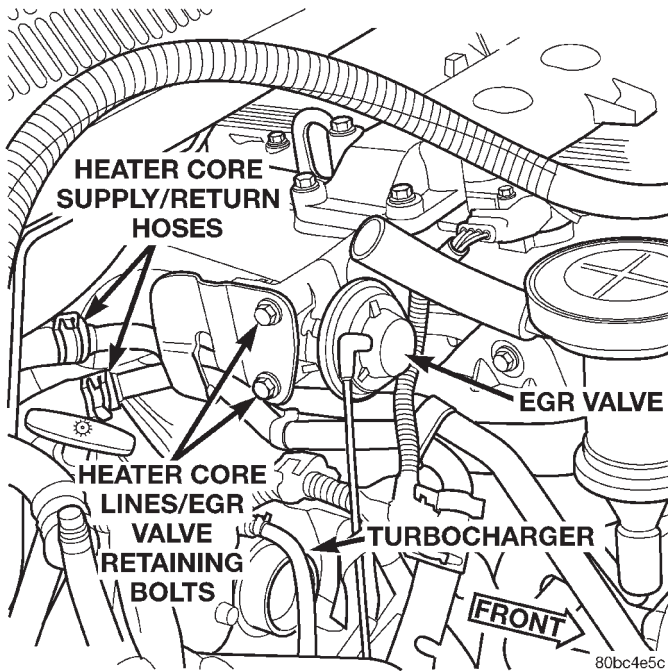

Fig. 56 Heater Hoses

(14) Remove the exhaust manifold/turbocharger heat shield (Fig. 57).

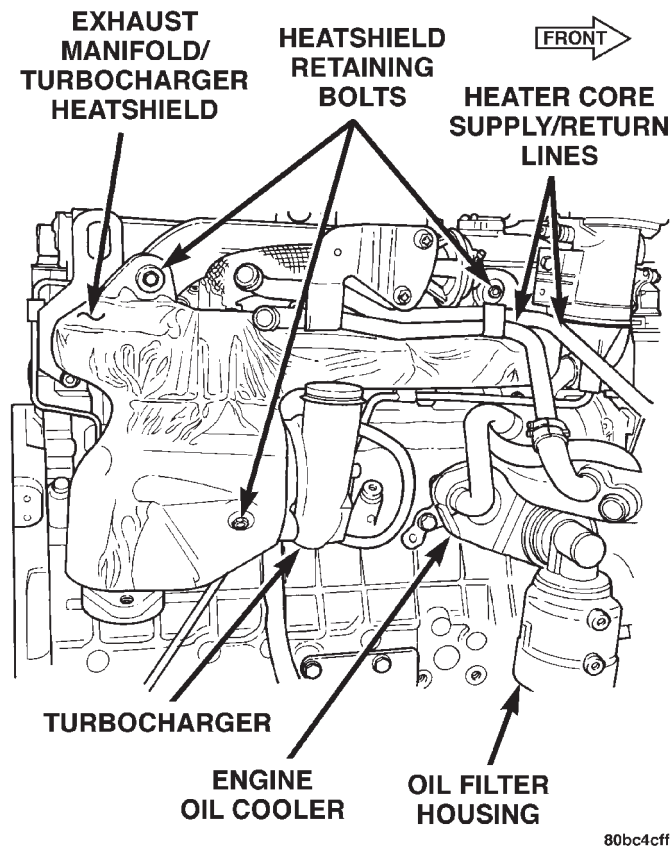

Fig. 57 Exhaust Manifold/Turbocharger Heat Shield

- (15) Disconnect the oil feed line from turbocharger.
- (16) Disconnect the oil return line from turbocharger (Fig. 58).

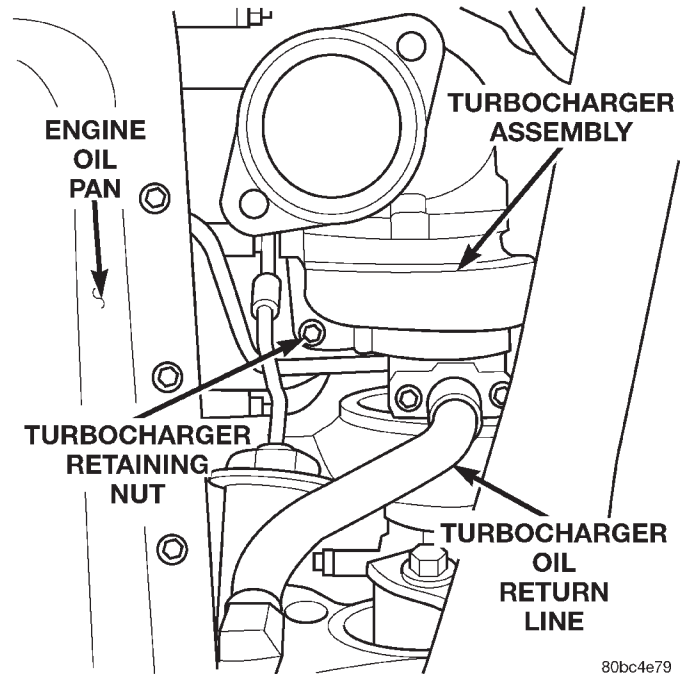

Fig. 58 Oil Return Line

- (17) Raise vehicle on hoist.
- (18) Disconnect the exhaust pipe at the turbocharger.
- (19) Remove the Exhaust manifold and turbocharger. Refer to Group 11, Exhaust System and Turbocharger.
- (20) Disconnect the boost pressure sensor electrical connector.
- (21) Remove the Intake manifold. Refer to intake manifold removal and installation procedure in this section.
- (22) Remove the oil feed line support bracket at rear of the cylinder head (Fig. 59).
- (23) Remove the oil feed line for rocker arm assemblies (Fig. 60).
- (24) Remove the Crankcase breather hose from front of the valve cover
- (25) Remove the injector sensor wire and the glow plug hot lead .
- (26) Remove the fuel injector supply lines from injectors.
- (27) Remove the fuel injectors with tool VM.1012 (Fig. 61). Refer to Group 14, Fuel System for procedure.
- (28) Remove the cylinder head cover. Refer to cylinder head cover removal and installation procedure in this section.

REMOVAL AND INSTALLATION (Continued)

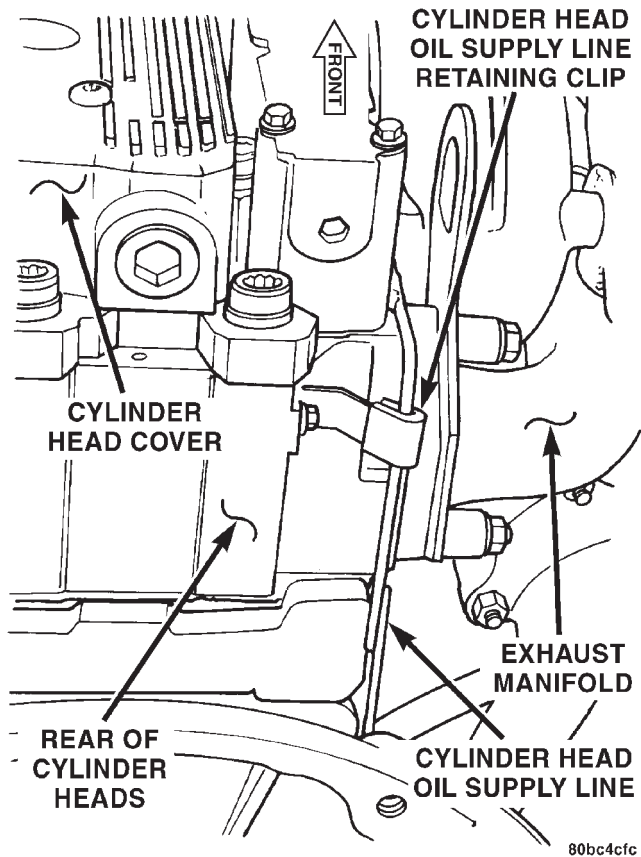

Fig. 59 Cylinder Head Oil Supply Line Retaining Clip

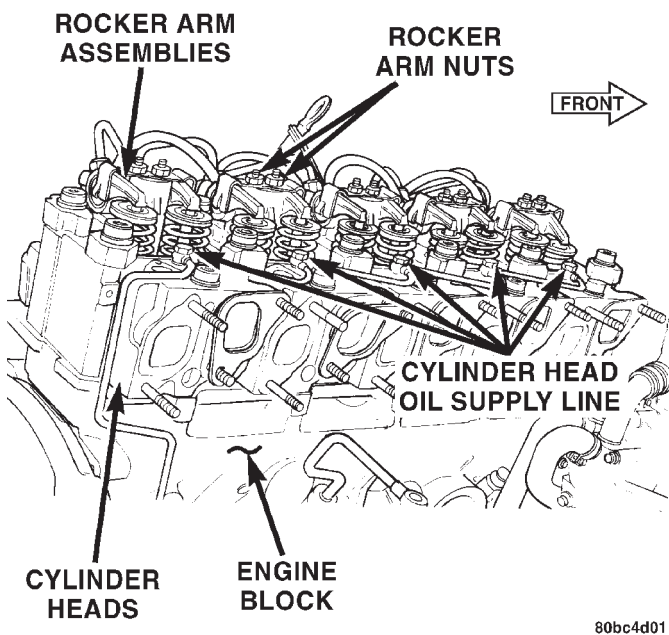

Fig. 60 Rocker Arm Oil Feed Lines

- (29) Remove the rocker retaining nuts (Fig. 63) (Fig. 64).
- (30) Remove the rocker arm assemblies. Place them on a bench in the same order as removed.

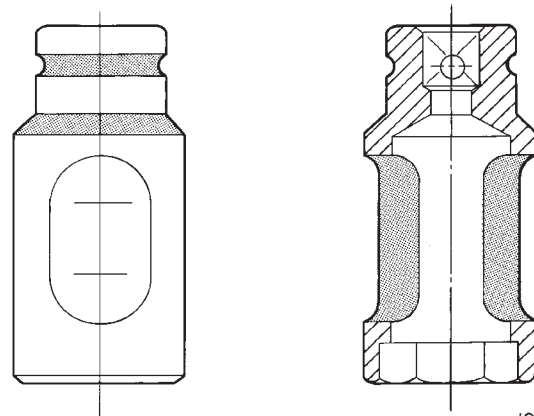

Fig. 61 Fuel Injector Tool VM.1012

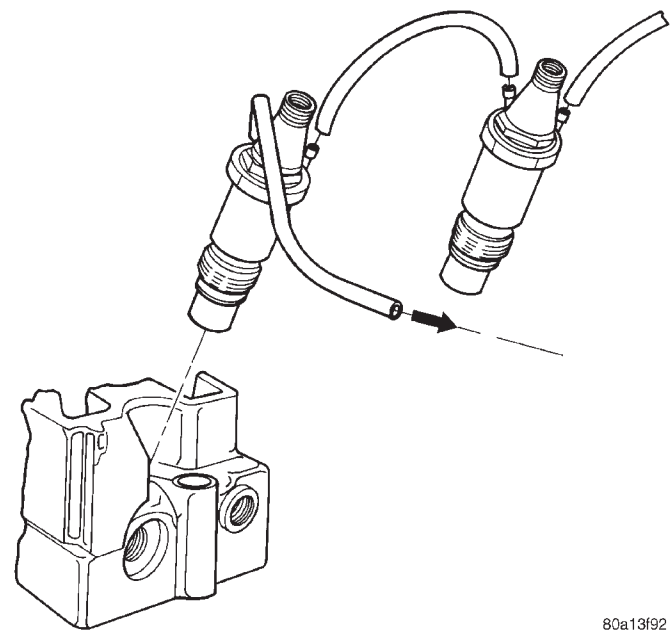

Fig. 62 Fuel Injector

- (31) Remove the push rods and place them on a bench in the same order as removed.
- (32) Mark the cylinder head positions.
- (33) Remove the engine cylinder head bolts with special tool VM.1018 and VM.1019.
- (34) Remove the engine cylinder head and gasket .
- (35) Stuff clean lint free shop towels into the cylinder bores.

CYLINDER HEAD GASKETS

A one piece steel cylinder head gasket is used for all five cylinder heads.

Cylinder head gaskets are available in three thicknesses. Identification holes or notches in the right front corner of the gasket indicate the thickness of the gasket (Fig. 65).

REMOVAL AND INSTALLATION (Continued)

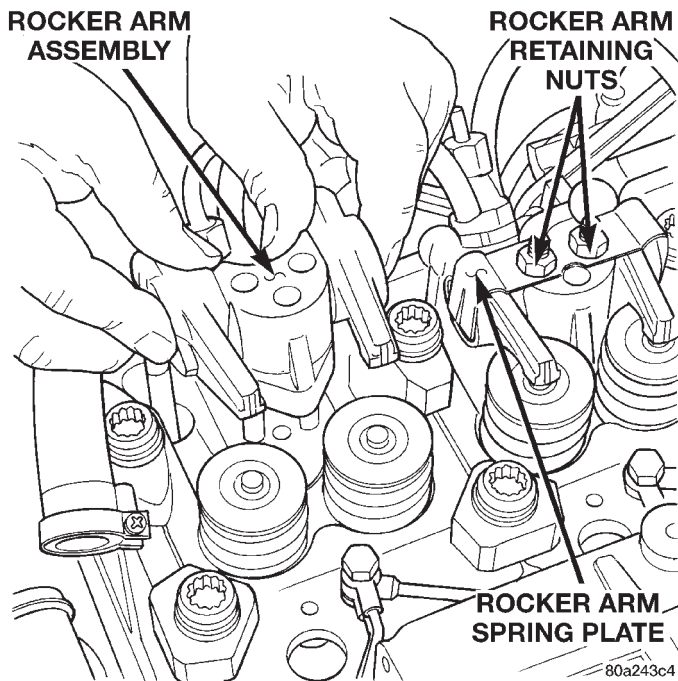
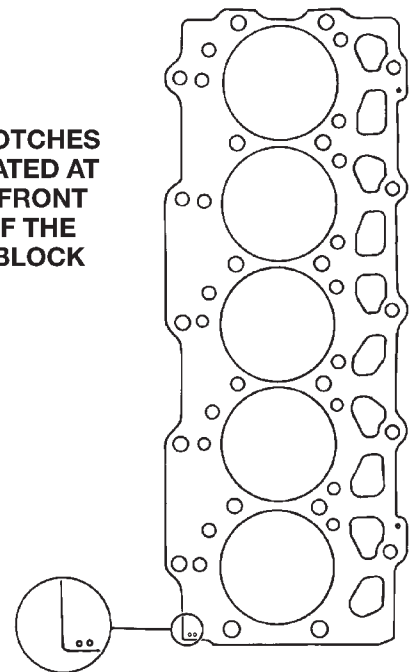

Fig. 63 *Rocker Arm Retaining Nuts*

**HOLES OR NOTCHES
CAN BE LOCATED AT
THE RIGHT FRONT
CORNER OF THE
CYLINDER BLOCK**



HOW TO IDENTIFY GASKET THICKNESS	
NO HOLES OR NOTCHES.....	1.41 mm
2 HOLES OR NOTCHES	1.51 mm
1 HOLE OR NOTCHES	1.61 mm

80bce9e9

Fig. 65 *Steel Type Cylinder Head Gasket—
identification*

CAUTION: Piston protrusion must be measured, to determine cylinder head gasket thickness, if one or more cylinder wall liners have been replaced.

NOTE: If cylinder wall liners have not been removed; the same thickness head gasket removed, may be used.

MEASURING PISTON PROTRUSION

- (1) Use special tool VM.1010 with dial indicator special tool VM.1013 (Fig. 66).
- (2) Bring the piston of cylinder no. 1 exactly to top dead center.
- (3) Zero the dial indicator on the cylinder block mating surface.
- (4) Setup the dial indicator on the piston crown (above the center of the piston pin) 5mm (1/8 in.) from the edge of the piston and note the measurement (Fig. 67).
- (5) Repeat the procedure with the rest of the cylinders.
- (6) Establish the thickness of the steel gasket for all four cylinder heads on the basis of the greatest piston protrusion (Fig. 65).

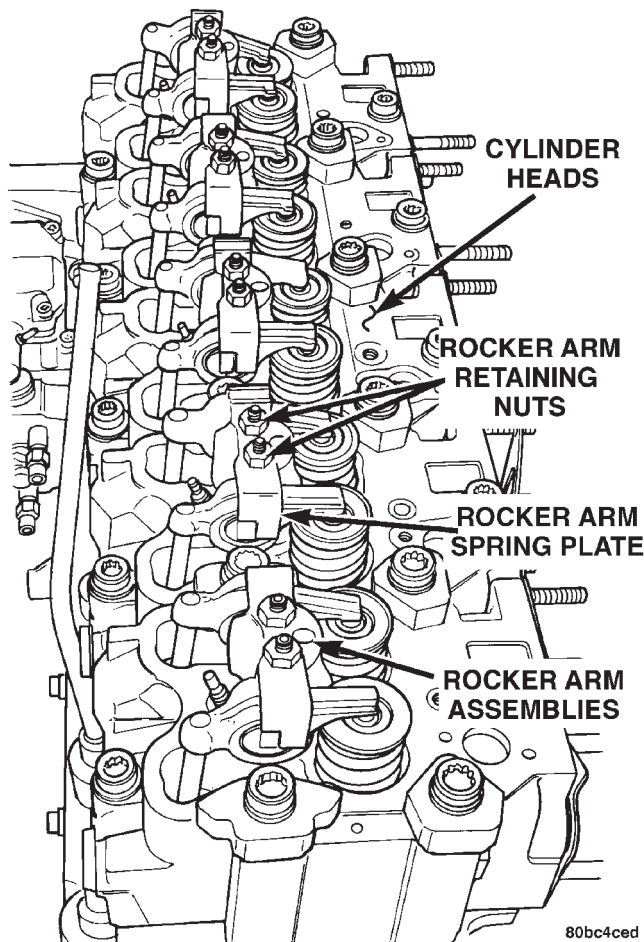

Fig. 64 *Rocker Arm Assemblies*

REMOVAL AND INSTALLATION (Continued)

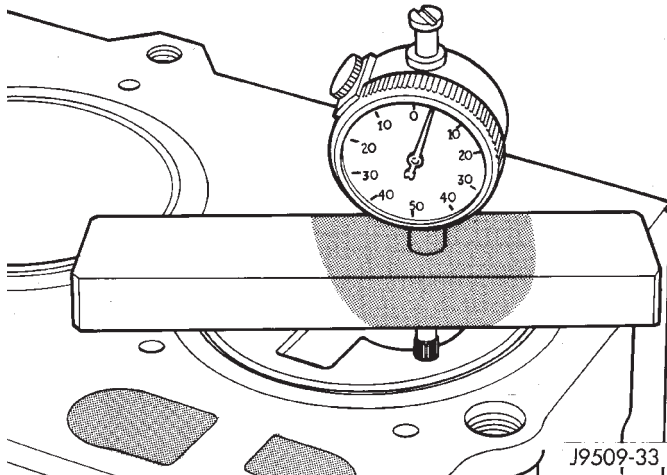

Fig. 66 Measuring Piston Protrusion

Measured dimension (mm)	0.53 - 0.62
Cyl. head gasket thickness (mm)	1.41
Piston clearance (mm)	0.80 - 0.89
Measured dimension (mm)	0.63 - 0.72
Cyl. head gasket thickness (mm)	1.51
Piston clearance (mm)	0.80 - 0.89
Measured dimension (mm)	0.73 - 0.82
Cyl. head gasket thickness (mm)	1.61
Piston clearance (mm)	0.80 - 0.89

80bce9e5

Fig. 67 Piston Protrusion Chart

CAUTION: The cylinder head gasket is to be installed DRY. DO NOT use a gasket sealing compound on the gasket.

INSTALLATION

- (1) Remove the shop towels from the cylinder bores. Coat the bores with clean engine oil.
- (2) Install cylinder head alignment studs VM.1009.
- (3) After determining the correct head gasket thickness, clean the block and head mating surfaces, place the engine cylinder head gasket over the alignment studs.
- (4) Place the engine cylinder head over the alignment studs.

CAUTION: New cylinder head bolts must be used.

- (5) Tighten the engine cylinder head bolts in sequence according to the following procedure (Fig. 68) :

a. The threads and underside heads of the bolts should be lubricated. Use the cylinder head alignment studs tool number VM-1009. Position the heads

on the block and secure with the twelve large center bolts and spacers (clamps), finger tight only.

b. Ensure that the various clamps are installed correctly and the head gasket remains in it's proper position, completely covered. Then, lubricate and install the ten small bolts, also finger tight.

(6) Install the intake and exhaust manifolds with a new gasket, partially tightening the nuts to a maximum of 5 N·m (44 in. lbs.). This will align the heads. Refer to Group 11, Exhaust System and Turbo-charger for the proper procedure.

(7) Then, tighten the 14mm bolts with special tool VM.1019 in the following manner:

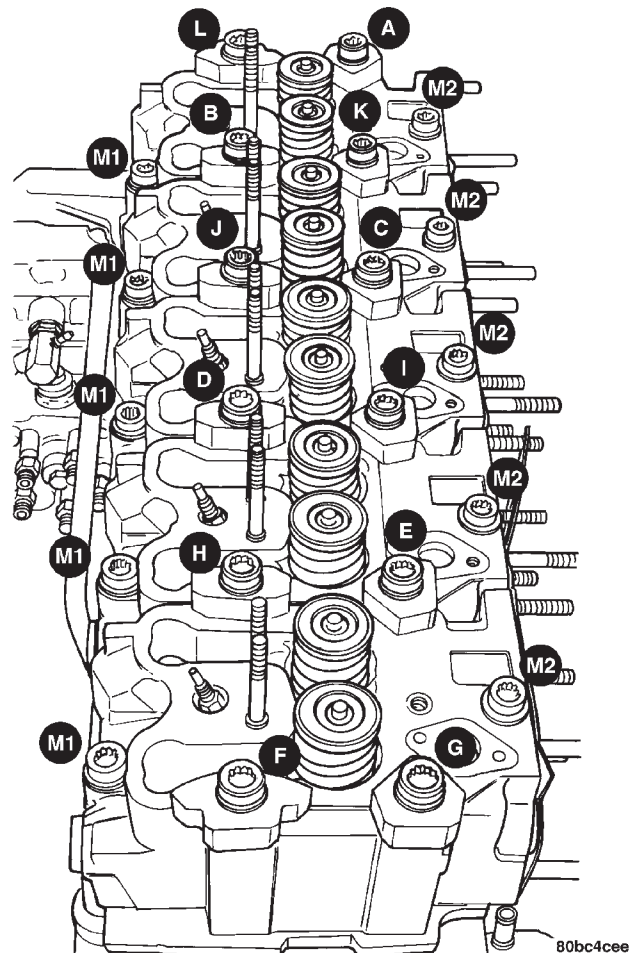

80bc4cee

Fig. 68 Engine Cylinder Head Bolt Tightening Sequence

(8) **1st Phase: Tightening Head Bolts** (Fig. 68). Central bolts (A-L): Tighten all bolts, starting with bolt I then J-K-L-A-B-C-D-E-F-G-H, to 30 N·m. Tighten all bolts an additional 70°, starting with bolt A and continuing in alphabetical order. Finally, tighten all bolts an additional 70°, starting again with bolt A and continuing in alphabetical order.

(9) Tighten the 12mm bolts in the following manner:

REMOVAL AND INSTALLATION (Continued)

(10) Side bolts (M1-M2): Tighten M1 bolts to 30 N·m, then rotate them 85° (±5). Tighten M2 bolts to 30 N·m, then rotate them 85° (±5).

NOTE: If vehicle is equipped with A/C do not install A/C lines to compressor and charge A/C till Phase 2 is complete.

(11) **2nd Phase:** After 20 minutes of engine operation at operating temperature, allow engine to cool down completely. Then retorquer the head bolts as follows:

(12) Central bolts A-L: Completely back off bolts one-by-one and then retighten to 30 N·m plus 130° (±5°). Then proceed in the same way, bolt by bolt, following alphabetical order, as indicated.

(13) Side bolts M1-M2: **Without slackening**, torque bolts M1 then bolts M2 to 90 N·m (66 ft. lbs.).

(14) Torque intake nuts to 28 N·m (20 ft. lbs.) and exhaust manifolds nuts to 32 N·m (24 ft. lbs.) after completing the cylinder head torquing procedure.

(15) Install the oil feed lines for the rocker arm assemblies. Torque oil feed lines to 13 N·m (115 in. lbs.) (Fig. 69).

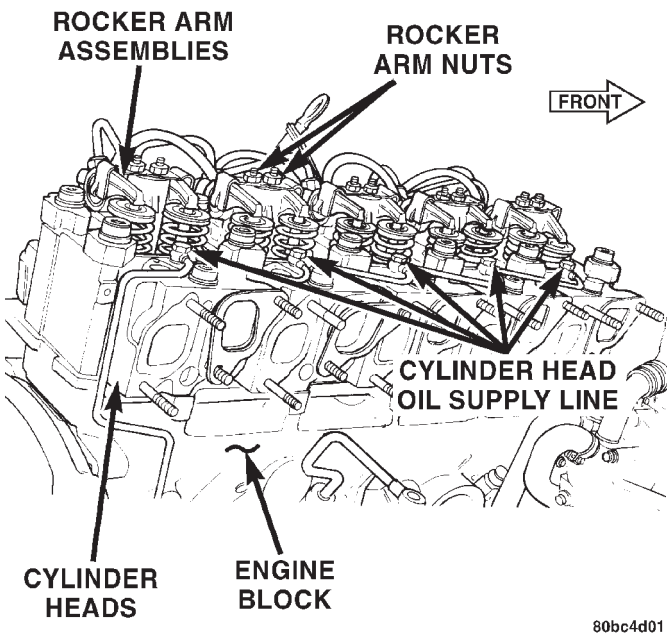

Fig. 69 Oil Feed Lines

(16) Install the oil feed line support bracket at rear of the cylinder head (Fig. 70). Torque bolt to 5.5 N·m (4 ft. lbs.).

(17) Install the push rods. (Fig. 71).

WARNING: During the installation of the rocker arm assemblies it is possible to cause valve interference between the piston and valve if the piston is near Top Dead Center (TDC). This is due to the slow

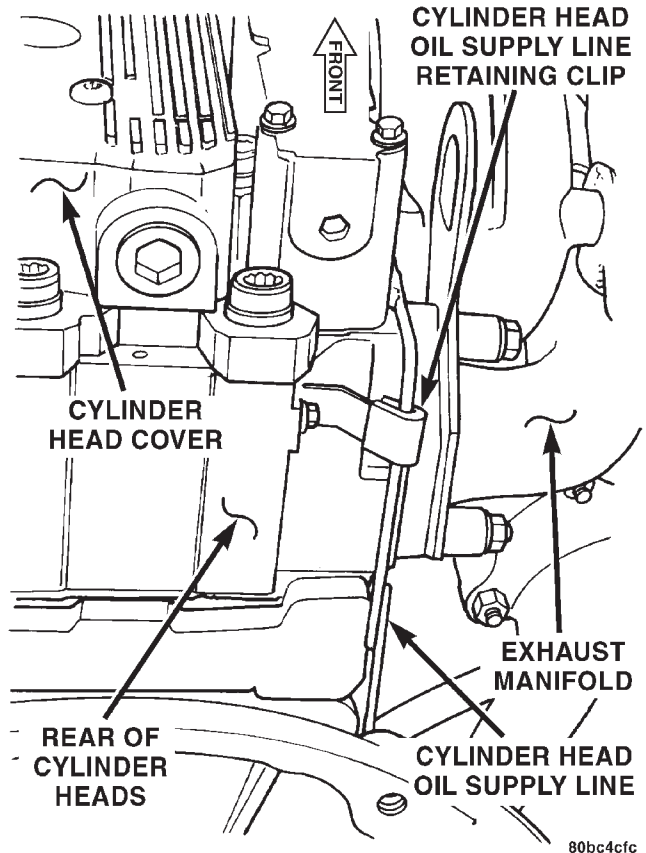

Fig. 70 Cylinder Head Oil Supply Line Retaining Clip

bleed down rate of the tappets when adjusting the rocker arm assemblies. Follow the procedure below to ensure that engine damage does not occur.

- Install the rocker arm assemblies in the same order as removed (Fig. 71).
 - Bring piston # 1 to Top Dead Center.
 - At this point tighten the rocker arm nuts for cylinder # 2-3-4-5. Torque nuts to 27 N·m (20 ft. lbs.).
 - Slowly rotate the crankshaft 90° clockwise or counterclockwise, then tighten the rocker arm nuts for cylinder # 1. Torque nuts to 27 N·m (20 ft. lbs.).
- (19) Install the cylinder head cover. Torque bolts to 15 N·m (133 in. lbs.) (Fig. 72).
- (20) Connect the crankcase breather hose to front of cylinder head cover.
- (21) Connect the injector sensor wire and the glow plug hot lead.
- (22) Install the turbocharger oil feed line. Torque banjo bolts to 27 N·m (20 ft. lbs.).
- (23) Install the turbocharger oil return line. Torque bolts to 11 N·m (97 in. lbs.).
- (24) Install the water manifold. Torque bolts to 12 N·m (106 in. lbs.).
- (25) Raise the vehicle on hoist.
- (26) Install the exhaust pipe to turbocharger. Torque bolts to 32 N·m (23 ft. lbs.).

REMOVAL AND INSTALLATION (Continued)

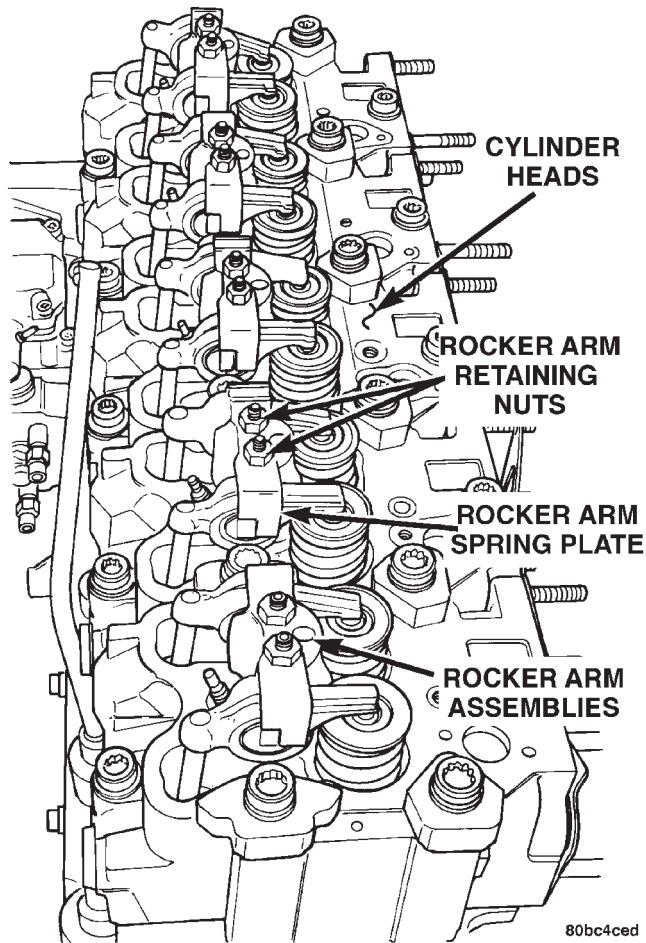

Fig. 71 Rocker Arm Assemblies

- (27) Lower vehicle form hoist.
- (28) Install the exhaust manifold/turbocharger heat shield. Torque bolts to 11 N·m (8 ft. lbs.).
- (29) Install the heater core supply lines.
- (30) Install the EGR valve/heater core supply line retaining bolts. Torque bolts to 28 N·m (20 ft. lbs.).
- (31) Install the intercooler hose to turbocharger.
- (32) Install the air cleaner hose to turbocharger.
- (33) Install the oil breather hose to air cleaner hose.
- (34) Connect the recover hose to water manifold.
- (35) Install the fuel injectors using special tool VM.1012. Refer to Group 14, Fuel System for procedures.
- (36) Install the fuel supply lines to injectors. Torque nuts to 19 N·m (14 ft. lbs.).
- (37) Connect the A/C lines to compressor and install bracket on cylinder head cover.
- (38) Connect the upper radiator hose.
- (39) Install the intake manifold elbow and intercooler hose.
- (40) Connect the negative cable battery.
- (41) Evacuate and charge the air conditioning system. Refer to Group 24, Heater and Air Conditioning.
- (42) Fill the cooling system. Check for leaks.

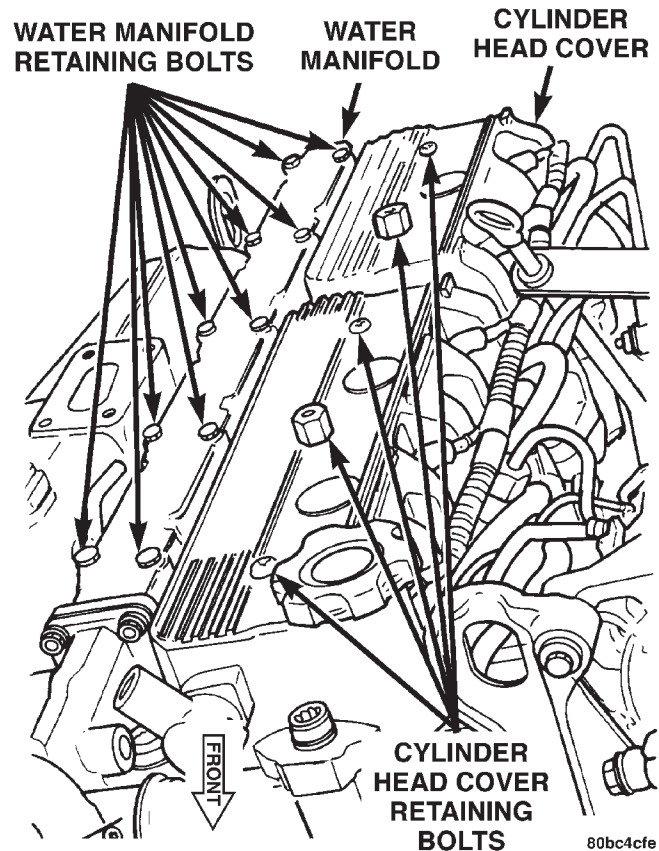

Fig. 72 Cylinder Head Cover

WARNING: USE EXTREME CAUTION WHEN THE ENGINE IS OPERATING. DO NOT STAND IN DIRECT LINE WITH THE FAN. DO NOT PUT HANDS NEAR THE PULLEYS, BELTS OR FAN. DO NOT WEAR LOOSE CLOTHING.

(43) Operate the engine with the radiator cap off. Inspect for leaks and continue operating the engine until the thermostat opens. Add coolant, if required.

NOTE: The one piece steel type head gasket does not require retorquing.

VIBRATION DAMPER

REMOVAL

- (1) Disconnect the negative battery cable.
- (2) Remove the fan and set fan inside fan shroud then remove fan shroud and fan as an assembly.
- (3) Remove the accessory drive belt. Refer to Group 7, Cooling System for procedure.
- (4) Remove the vibration damper nut.
- (5) Install special tool VM.1000-A to remove vibration damper (Fig. 73).

REMOVAL AND INSTALLATION (Continued)

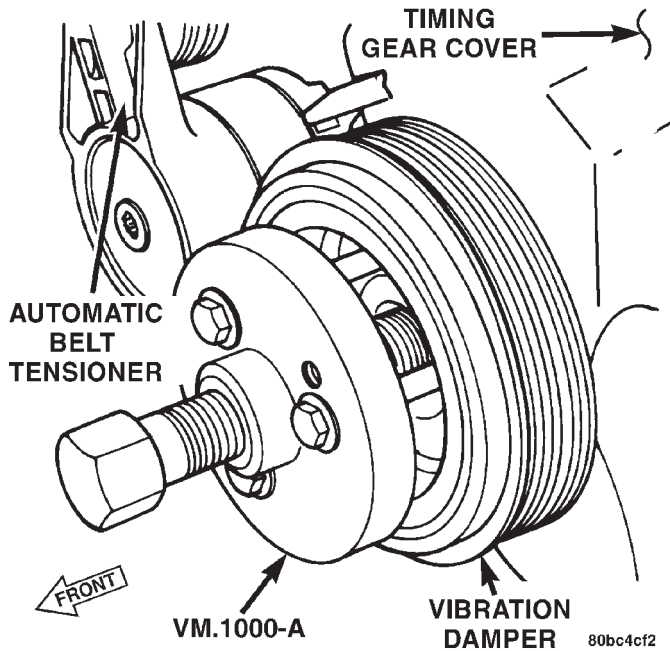

Fig. 73 VM.1000-A

INSTALLATION

- (1) Install the vibration damper and align with key way.
- (2) Install the vibration damper nut. Torque nut to 196 N-m (147 ft. lbs.).
- (3) Install the accessory drive belt. Refer to Group 7, Cooling System for procedure.
- (4) Connect the negative battery cable.

TIMING GEAR COVER OIL SEAL

REMOVAL

- (1) Disconnect the negative battery cable.
- (2) Remove the vibration damper. Refer to vibration damper removal and installation procedure in this section.

CAUTION: Use care when removing the old seal. Be sure not to damage the timing gear cover .

- (3) Pry out the old seal.

INSTALLATION

- The seating diameter must be 68.000 - 68.030 mm.
- (1) Install the new seal using special tool VM.1015A (Fig. 75).
 - (2) Install the vibration damper. Refer to vibration damper removal and installation procedure in this section.
 - (3) Connect the negative battery cable.

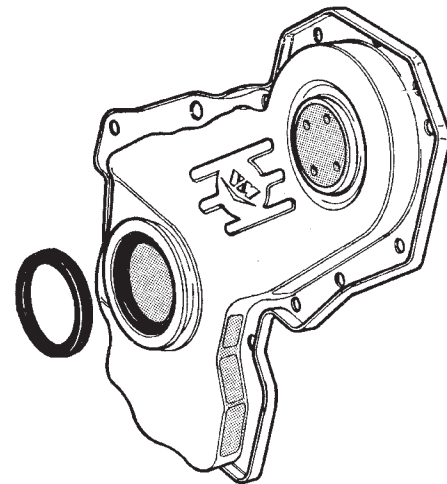

Fig. 74 Timing Gear Cover Oil Seal

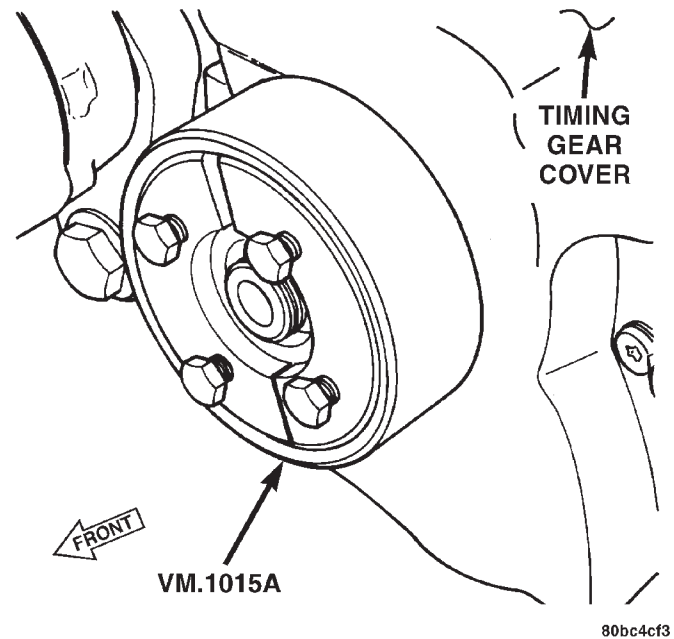

Fig. 75 VM.1015-A

TIMING GEAR COVER

REMOVAL

- (1) Disconnect the negative battery cable.
- (2) Remove the fan and set fan inside fan shroud then remove fan shroud and fan as an assembly.
- (3) Remove the accessory drive belt. Refer to Group 7, Cooling System for procedure.
- (4) Remove the vibration damper nut.
- (5) Install special tool VM.1000-A to remove the vibration damper (Fig. 76).
- (6) Remove the fan pulley (Fig. 77).

NOTE: The idler pulleys have left hand threaded bolts.

REMOVAL AND INSTALLATION (Continued)

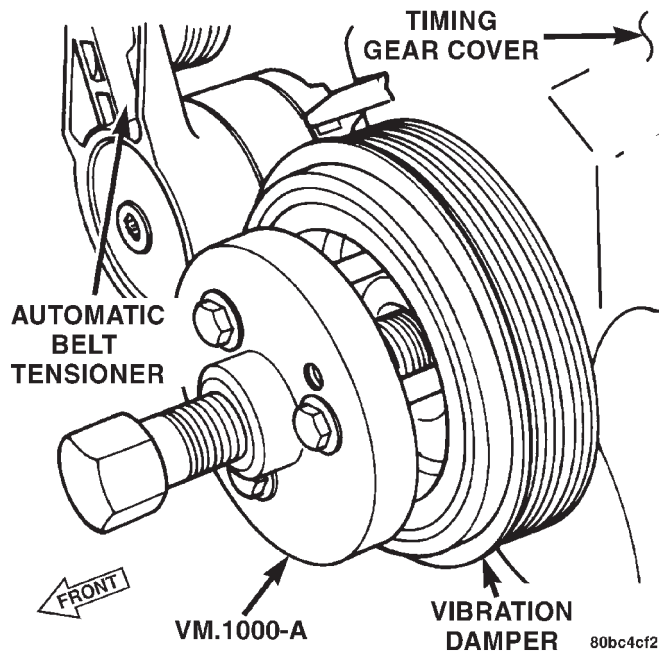

Fig. 76 VM.1000-A

- (7) Remove the idler pulley and bracket (Fig. 77).
- (8) Remove the automatic belt tensioner (Fig. 77).
- (9) Remove the Power steering pump pulley (Fig. 77).
- (10) Remove the timing gear cover.

INSTALLATION

- (1) Be sure the mating surfaces of the gear case cover and the cylinder block are clean and free from burrs.
- (2) Apply a continuous 3 mm bead of Silicone Sealer (Fig. 78) to timing cover, install within 10 minutes, tighten 6mm bolts to 11 N·m (8 ft. lbs.) and tighten 8mm bolts to 26.2 N·m (19 ft. lbs.).
- (3) Install Power steering pump pulley. Torque bolts to 25 N·m (18 ft. lbs.).
- (4) Install the automatic belt tensioner.
- (5) Install the idler pulley bracket. Torque bolts to 47 N·m (34 ft. lbs.).

NOTE: The idler pulley has left hand thread.

- (6) Install the idler pulleys. Torque nut to 47 N·m (34 ft. lbs.).
- (7) Install the fan pulley. Torque bolts to 28 N·m (21 ft. lbs.).
- (8) Install the vibration damper. Torque nut to 196 N·m (147 ft. lbs.).
- (9) Install the accessory drive belt. Refer to Group 7, Cooling System for procedure.
- (10) Install the fan and fan shroud.
- (11) Connect the negative battery cable.

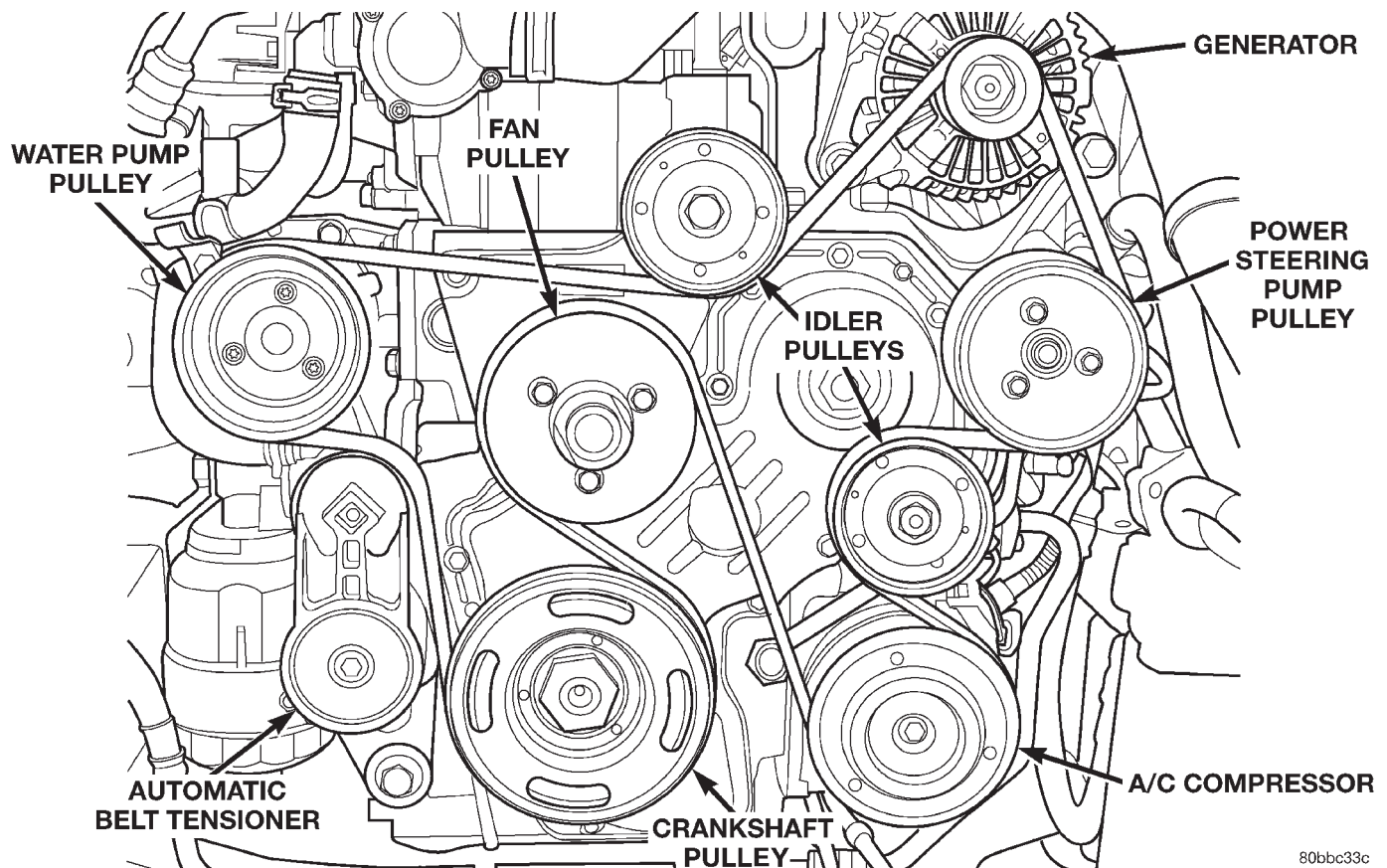
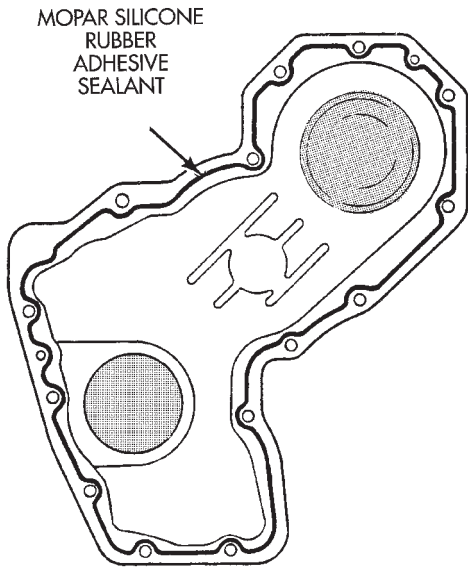

Fig. 77 Idler Pulley And Tensioner Location

REMOVAL AND INSTALLATION (Continued)



J9509-7

Fig. 78 Front Cover Sealer Location

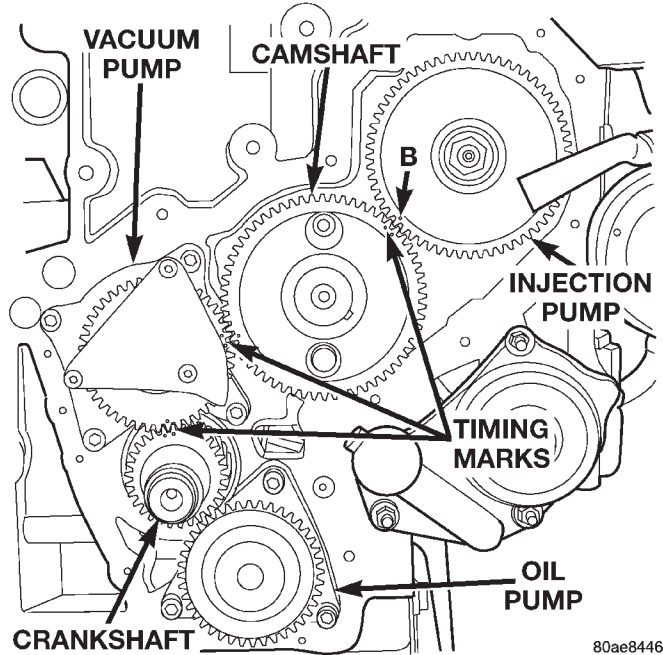

80ae8446

Fig. 79 Timing Marks

CAMSHAFT

REMOVAL

- (1) Disconnect the negative battery cable.
- (2) Remove the cylinder head cover. Refer to cylinder head cover removal and installation in this section.
- (3) Remove the cylinder heads. Refer to cylinder head removal and installation in this section.
- (4) Remove the rocker arm assemblies, push rods, and hydraulic tappets. Refer to the respective groups in this section.
- (5) Remove the fan and set fan inside fan shroud then remove fan shroud and fan as an assembly.
- (6) Remove the accessory drive belt. Refer to Group 7, Cooling System for procedure.
- (7) Remove the radiator, A/C condensor, and inter-cooler as an assembly. Refer to Group 7, Cooling System for procedure.
- (8) Remove the vibration damper. Refer to vibration damper removal and installation in this section.
- (9) Remove the power steering pump pulley.
- (10) Remove timing gear cover. Refer to timing gear cover removal and installation in this section.
- (11) Rotate the engine to align the timing marks as shown (Fig. 79).

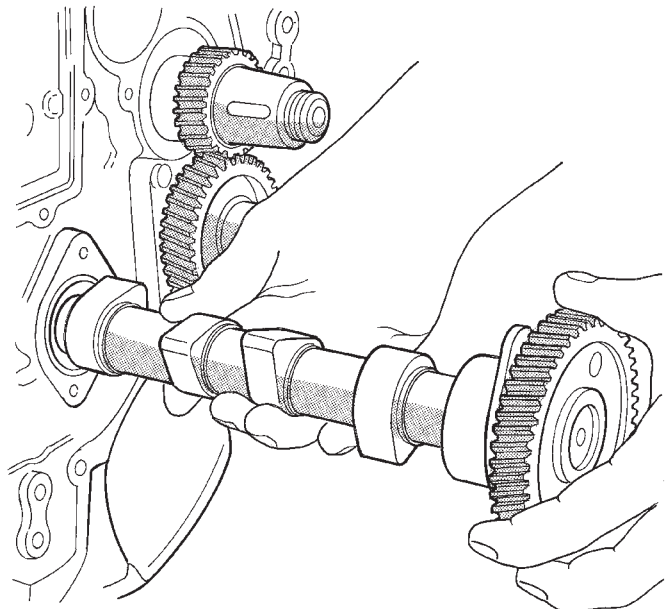

J9509-15

Fig. 80 Camshaft Removal

NOTE: The oil dipstick tube must be removed for camshaft removal.

- (12) Unscrew the flange bolts and remove camshaft (Fig. 80).

THRUST PLATE INSPECTION

Check the thickness (Fig. 81) of the plate at points a-b-c-d. If the measurement is not between 3.950 - 4.050 it must be changed.

INSTALLATION

- (1) Coat the camshaft journals with clean engine oil and carefully install the camshaft complete with thrust plate and gear. Tighten retaining bolts to 18 N·m (13 ft. lbs.). Be sure to align the timing marks as shown (Fig. 82).

REMOVAL AND INSTALLATION (Continued)

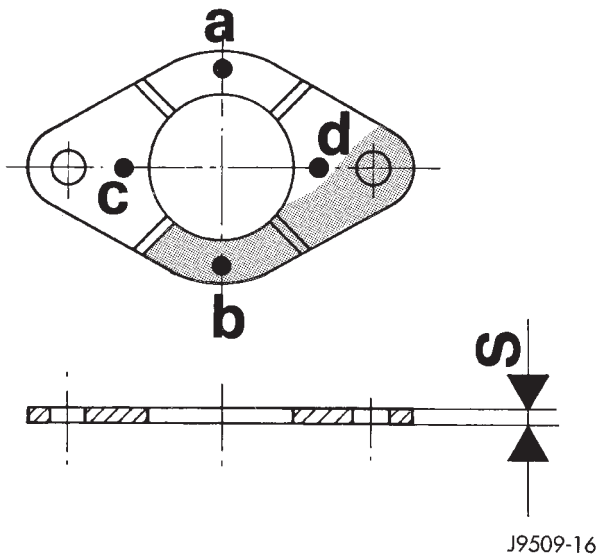

Fig. 81 Camshaft Thrust Plate

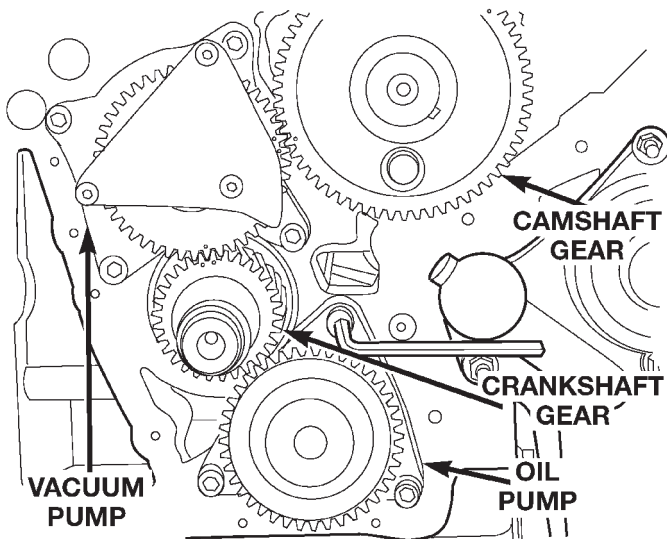

Fig. 82 Timing Marks

(2) Install the hydraulic tappets and retainers. Refer to hydraulic tappet removal and installation in this section.

(3) Install the cylinder heads. Refer to cylinder head removal and installation in this section.

(4) Install the push rods and rocker arm assemblies. Refer to the respective sections.

(5) Install the cylinder head cover. Refer to cylinder head cover removal and installation in this section.

(6) Install the timing gear cover. Refer to timing gear cover removal and installation in this section.

(7) Install the vibration damper. Refer to the vibration damper removal and installation in this section.

(8) Install the radiator, A/C condenser, and intercooler. Refer to Group 7, Cooling System for procedure.

(9) Install the fan and fan shroud. Torque fan to 56 N·m (41 ft. lbs.).

(10) Evacuate and charge the air conditioning system. Refer to Group 24, Heater and Air Conditioning for procedure.

(11) Connect the negative battery cable.

(12) Fill the cooling system. Check for leaks.

WARNING: USE EXTREME CAUTION WHEN THE ENGINE IS OPERATING. DO NOT STAND IN DIRECT LINE WITH THE FAN. DO NOT PUT HANDS NEAR THE PULLEYS, BELTS OR FAN. DO NOT WEAR LOOSE CLOTHING.

(13) Operate the engine with the radiator cap off. Inspect for leaks and continue operating the engine until the thermostat opens. Add coolant, if required.

CAMSHAFT BEARINGS

This procedure requires that the engine is removed from the vehicle.

REMOVAL

(1) With the engine completely disassembled, install the Camshaft Bearing Remover/Installer Tool VM.1040 (Fig. 83).

(2) Pull the camshaft bearings out of the cylinder block.

INSTALLATION

CAUTION: Be sure the oil holes in the center bearings are lined up with oil gallery holes in the cylinder block.

(1) Install the front and rear camshaft bearings with Camshaft Bearing Remover/Installer Tool VM.1040.

(2) Push the new bearings into place.

(3) Install the remaining bearings in the same manner. The Bearings must be carefully aligned to bring oil holes into full register with oil passages from the main bearing. If the camshaft bearing shell oil holes are not in exact alignment, remove and install them correctly.

REMOVAL AND INSTALLATION (Continued)

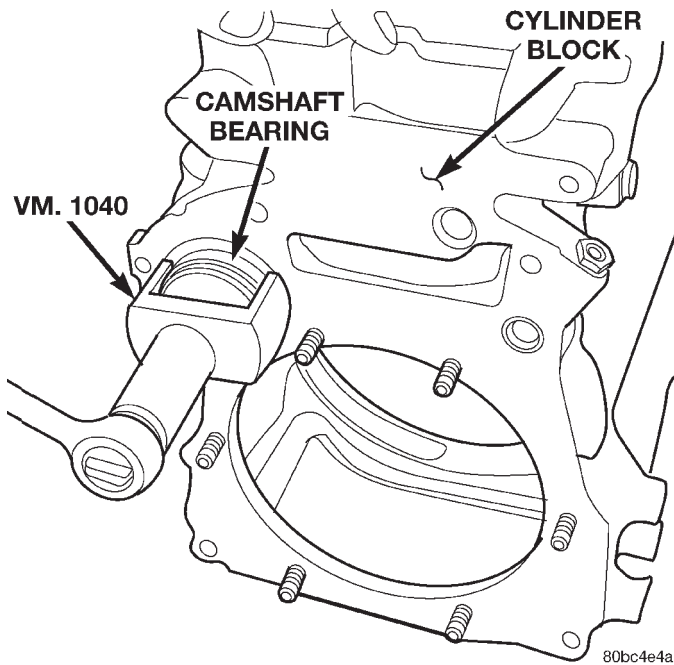

Fig. 83 VM.1040

- (2) Remove the timing gear cover. Refer to timing gear cover removal and installation in this section.
- (3) Remove the oil pump (Fig. 84).

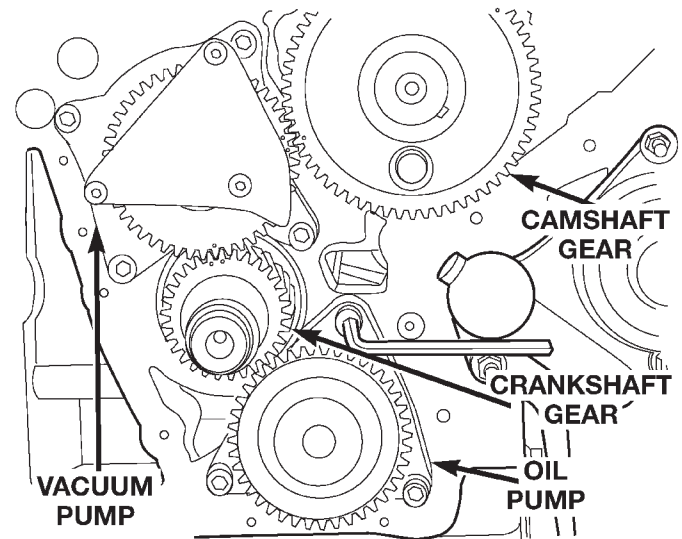

Fig. 84 Oil Pump Removal

OIL PAN

REMOVAL

- (1) Disconnect the negative battery cable.
- (2) Raise the vehicle on hoist.
- (3) Drain the oil.
- (4) Remove the oil pan lower cover.
- (5) Remove the bolts from oil pan. Remove the 6 bolts that are on the inside of the oil pan.
- (6) Remove the oil pan.

INSTALLATION

- (1) Remove all gasket material from cylinder block. Be careful not gouge or scratch aluminum pan sealing surface.
- (2) Apply a continuous 3 mm bead of Silicone Sealer to oil pan, install within 10 minutes. Install the oil pan.
- (3) Install the oil pan bolts. Torque bolts to 13 N·m (9 ft. lbs.).
- (4) Install the oil pan lower cover. Torque bolts to 13 N·m (9 ft. lbs.).
- (5) Install the oil drain plug. Torque to 79 N·m (58 ft. lbs.).
- (6) Lower the vehicle from hoist.
- (7) Fill engine with proper amount of oil.
- (8) Connect the negative battery cable.

OIL PUMP

REMOVAL

- (1) Disconnect the negative battery cable.

INSTALLATION

- (1) Install new O-ring and lubricate with clean engine oil.
- (2) Install the oil pump. Torque screws to 28 N·m (20 ft. lbs.). Check for normal backlash between pump and crankshaft gears.
- (3) Install the timing gear cover. Refer to timing gear cover removal and installation in this section.

INTERNAL VACUUM PUMP

REMOVAL

- (1) Disconnect the negative battery cable.
- (2) Remove the timing gear cover. Refer to timing gear cover removal and installation in this section.
- (3) Align all the timing marks before removing the vacuum pump (Fig. 85).
- (4) Remove the vacuum pump retaining bolts..
- (5) Remove the internal vacuum pump.

INSTALLATION

- (1) To install the vacuum pump, align the outer part of the gear with the inner part using a screwdriver or similar tool, align with timing marks on gear set and install (Fig. 85). Torque bolts to 28 N·m (20 ft. lbs.).
- (2) Install the timing gear cover. Refer to timing gear cover removal and installation in this section.
- (3) Connect the negative battery cable.

REMOVAL AND INSTALLATION (Continued)

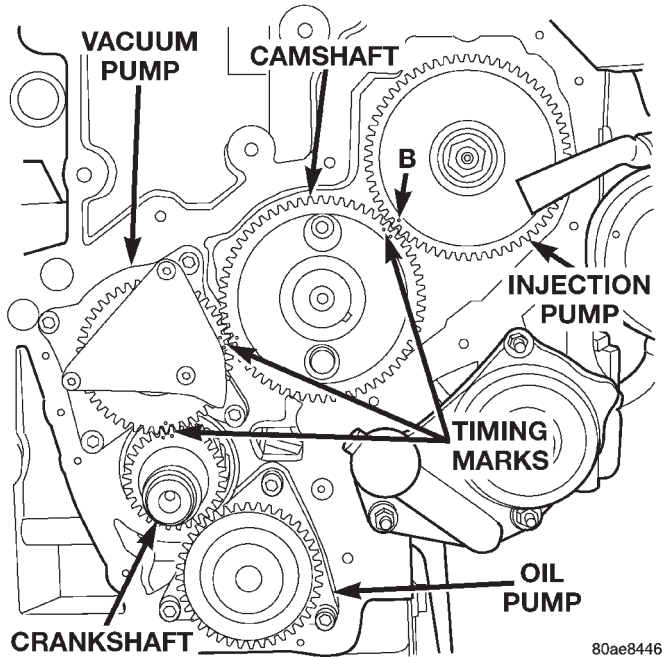

Fig. 85 Timing Marks

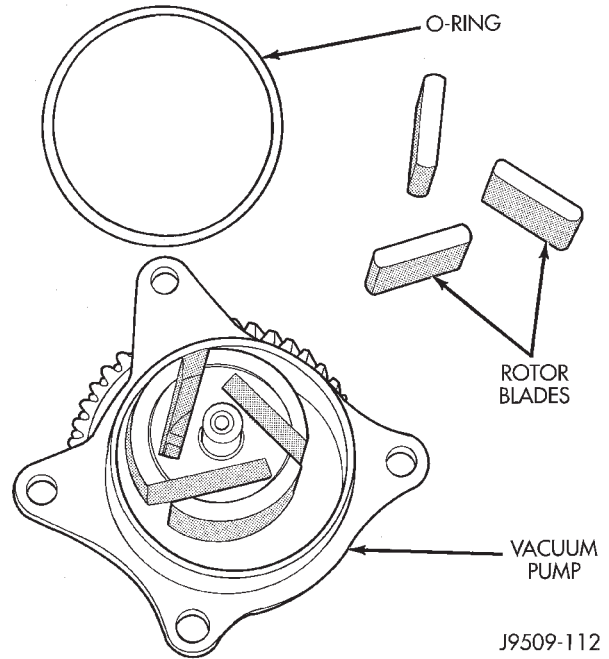

Fig. 87 Vacuum Pump Parts

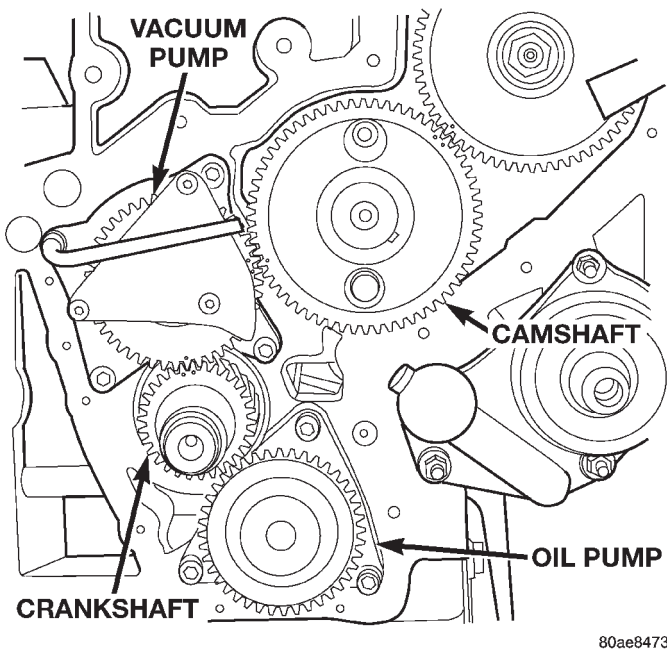

Fig. 86 Vacuum Pump

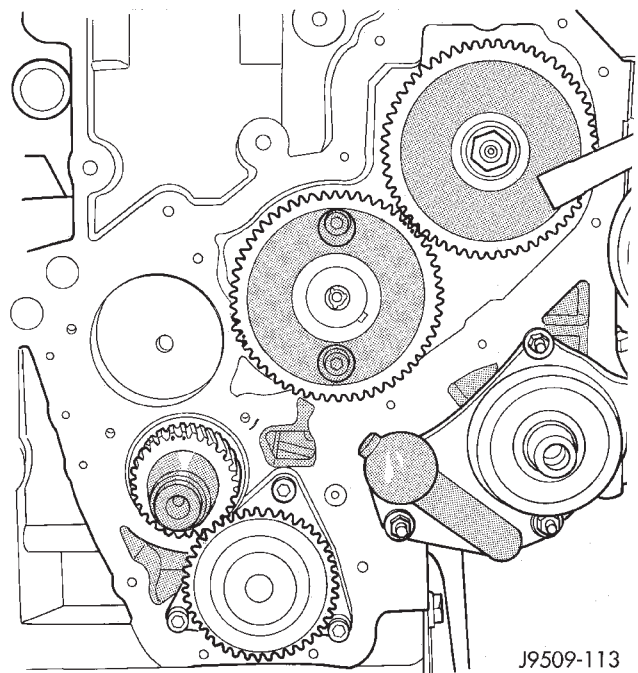

Fig. 88 Vacuum Pump Mounting Hole

OIL PUMP PRESSURE RELIEF VALVE

REMOVAL

- (1) Disconnect the negative battery cable
- (2) Remove the oil pan. Refer to oil pan removal and installation procedure in this section.
- (3) Remove the relief valve snap ring.
- (4) Remove the relief valve cap, spring, and plunger (Fig. 89).

- (5) Check the relief valve spring length. Relief valve spring free length is 57.5mm (2.263 in.). If spring length is less or spring is distorted it must be replaced.
- (6) Check the plunger for scoring, replace if necessary.

INSTALLATION

- (1) Thoroughly clean all components and relief valve pocket in cylinder block.

REMOVAL AND INSTALLATION (Continued)

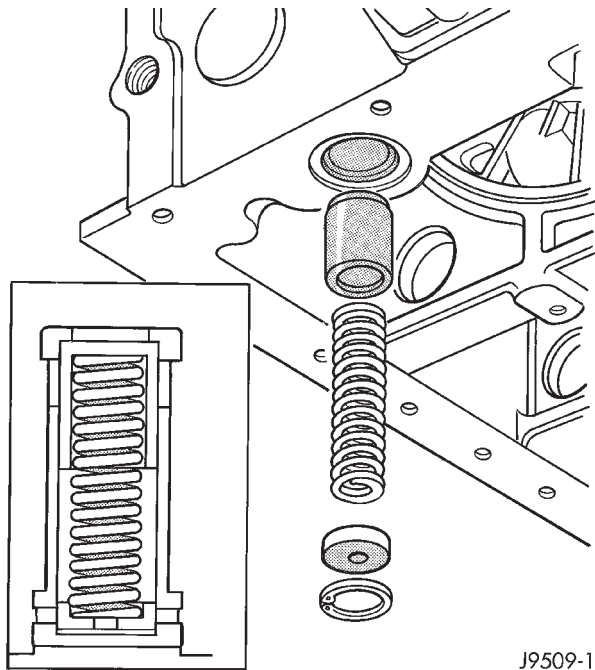

J9509-165

Fig. 89 Oil Pressure Relief Valve

- (2) Fit plunger, spring and cap into block.
- (3) Compress spring and install the snap ring. Ensure the snap ring is completely seated in groove.
- (4) Install the oil pan. Refer to oil pan removal and installation procedure in this section.
- (5) Connect the negative battery cable.

OIL FILTER ADAPTER AND OIL COOLER

REMOVAL

- (1) Disconnect the negative battery cable.
- (2) Remove the oil cooler coolant hoses.
- (3) Remove the oil filter housing/oil cooler retaining bolt (Fig. 90).
- (4) Remove the oil filter housing and oil cooler (Fig. 91).

INSTALLATION

- (1) Install the oil cooler and oil filter housing with a new gasket. Torque bolt to 46.6 N·m (34 ft. lbs.).
- (2) Install the oil cooler coolant hoses.
- (3) Connect the negative battery cable.

ENGINE OIL FILTER

REMOVAL

- (1) Raise the vehicle on a hoist.
- (2) Position a drainpan under the oil filter housing (Fig. 93).
- (3) Remove the oil filter housing drain plug. Located in the center of the housing cap. Drain the engine oil from the oil filter housing.

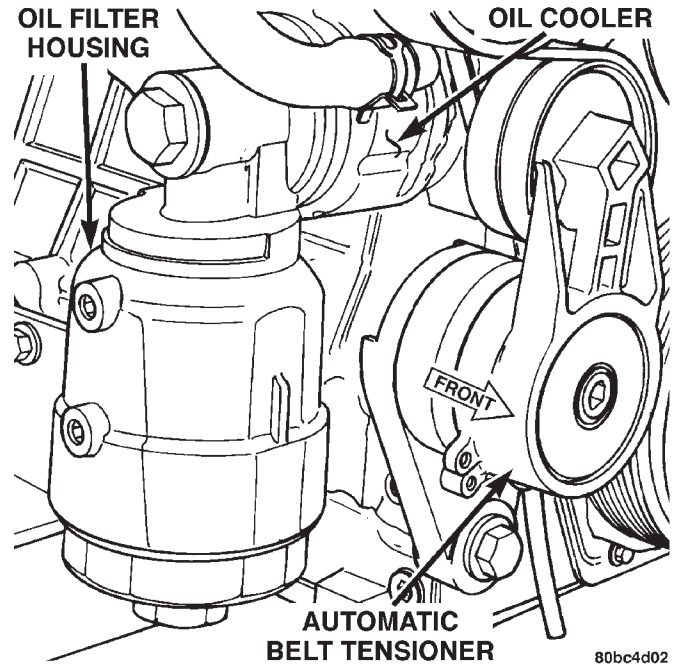

80bc4d02

Fig. 90 Oil Filter Housing

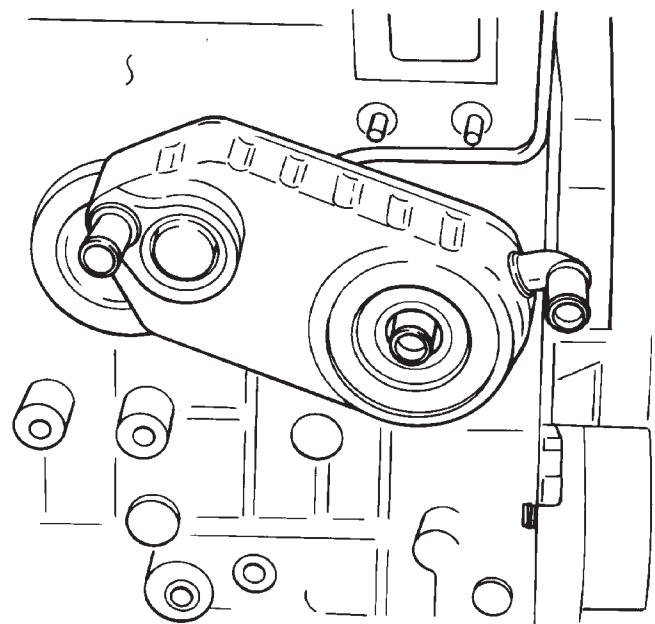

Fig. 91 Oil Cooler

- (4) Remove the oil filter housing cap by rotating counter-clockwise.
- (5) If the element remains in the housing remove the oil filter element by pulling it straight down and out of the oil filter housing.
- (6) Remove the oil filter housing sealing o-ring from the housing cap and discard. A new o-ring is supplied with the oil filter element.
- (7) Clean the oil filter housing and housing cap with shop solvent

REMOVAL AND INSTALLATION (Continued)

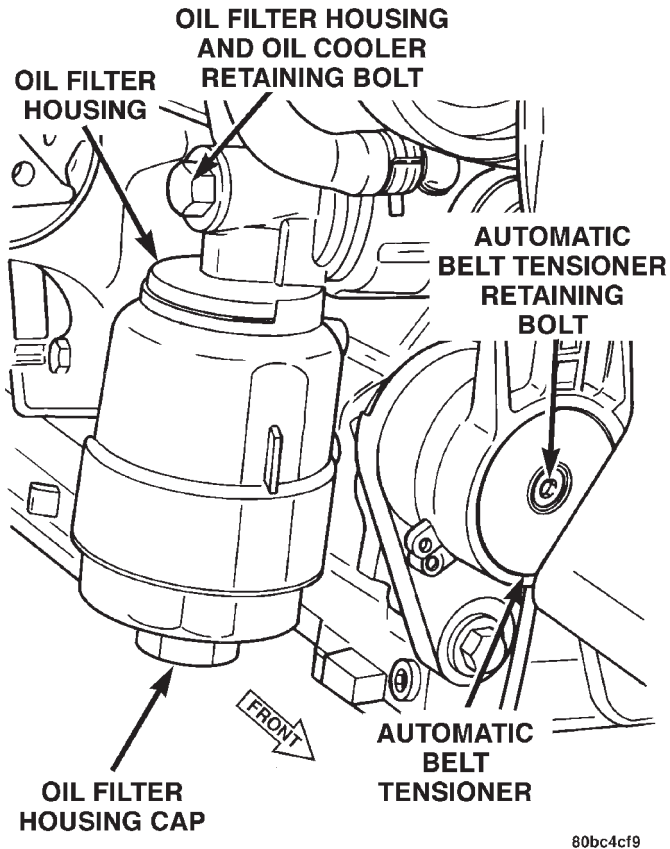

Fig. 92 Oil Filter Position & Orientation

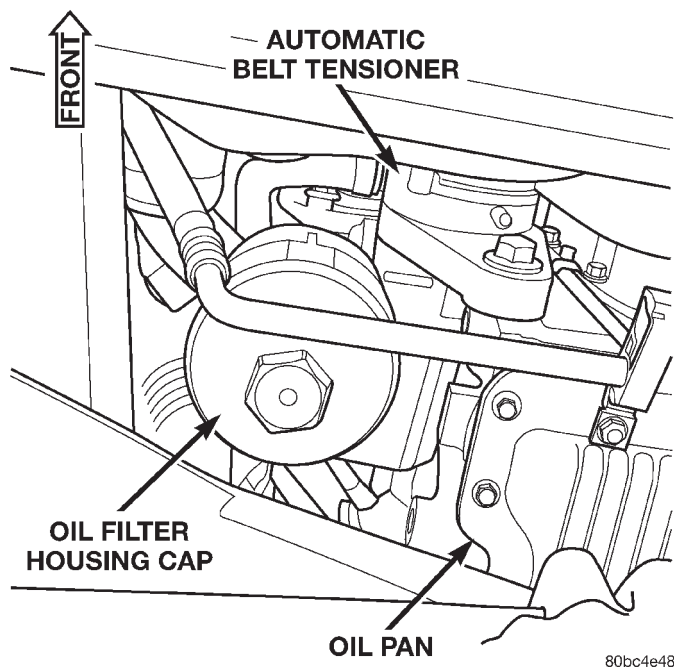

Fig. 93 Oil Filter Housing Cap

INSTALLATION

(1) Install a new sealing o-ring in the housing cap and lubricate with fresh engine oil.

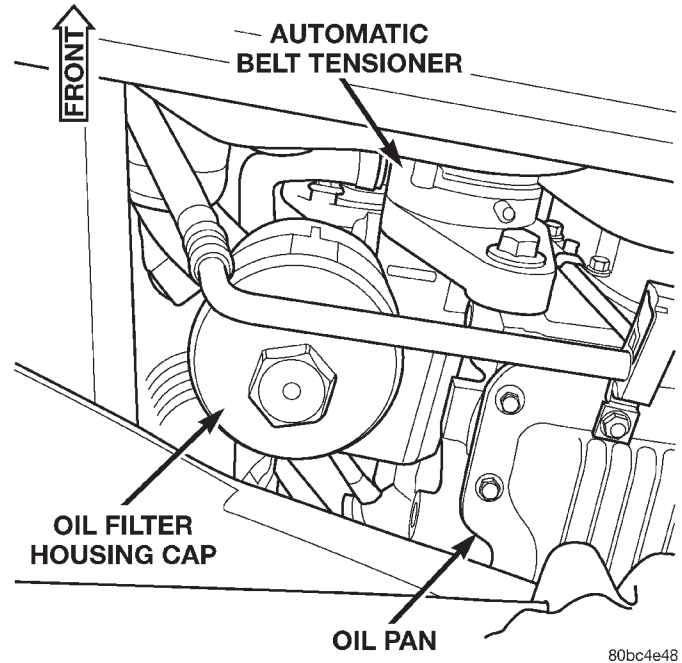

Fig. 94 Oil Filter Housing Cap

(2) Install the new filter element in the housing and install cap. Torque to 22.5 N·m (194in. lbs.) (Fig. 94).

(3) Install the oil filter housing drain plug. Torque to 12 N·m (106in. lbs.).

(4) Lower the vehicle on hoist.

(5) Fill the engine oil level to specification.

(6) Start the engine and check for leaks.

PISTONS AND CONNECTING ROD ASSEMBLY

REMOVAL

(1) Disconnect the battery cable.

(2) Remove cylinder heads, refer to cylinder head removal and installation in this section.

(3) Raise vehicle on hoist.

(4) Remove oil pan, refer to oil pan removal and installation in this section.

(5) Remove top ridge of cylinder bores with a ridge reamer before removing pistons from cylinder block. **Be sure to keep tops of pistons covered during this operation.** Mark piston with matching cylinder number.

(6) Pistons and connecting rods must be removed from top of cylinder block. Rotate crankshaft so that each connecting rod is centered in cylinder bore.

(7) Remove connecting rod cap bolts and cap. Push each piston and rod assembly out of cylinder bore.

NOTE: Be careful not to nick crankshaft journals.

(8) After removal, install bearing cap on the mating rod.

REMOVAL AND INSTALLATION (Continued)

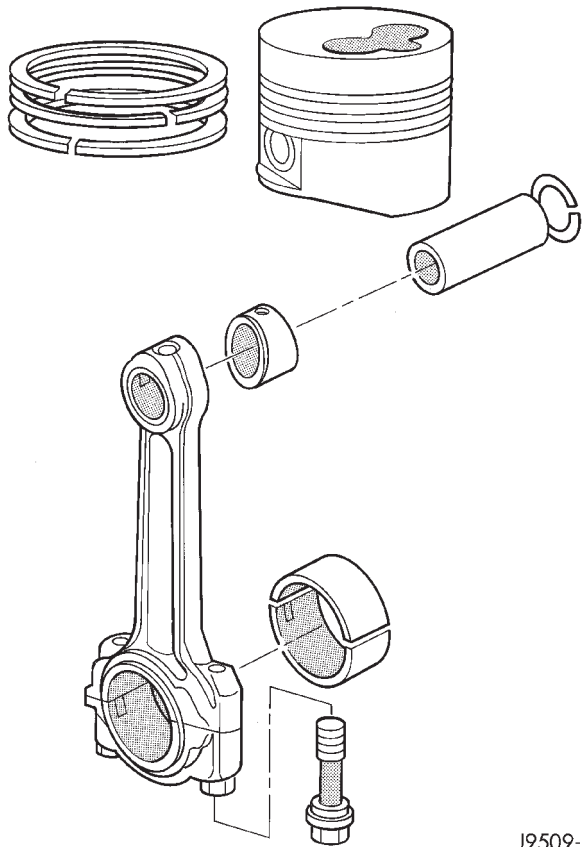

Fig. 95 Piston Assembly

PISTON PIN—REMOVAL

- (1) Secure connecting rod in a soft jawed vice.
- (2) Remove 2 clips securing piston pin.
- (3) Push piston pin out of piston and connecting rod.

PISTON RING—REMOVAL

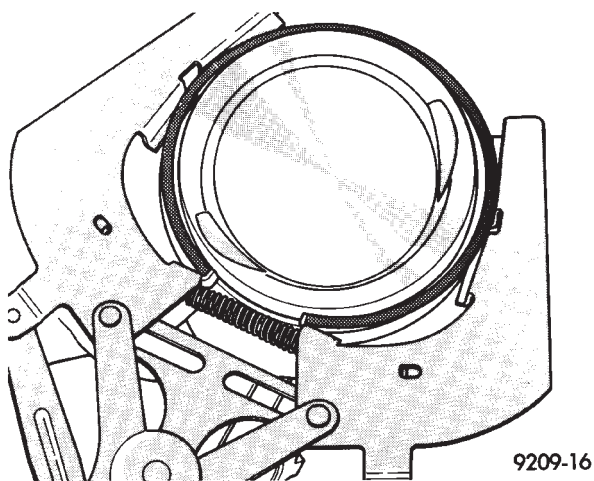

Fig. 96 Piston Rings—Removing and Installing

- (1) ID mark on face of upper and intermediate piston rings must point toward piston crown.

- (2) Using a suitable ring expander, remove upper and intermediate piston rings (Fig. 96).
- (3) Remove the upper oil ring side rail, lower oil ring side rail and then oil ring expander from piston.
- (4) Carefully clean carbon from piston crowns, skirts and ring grooves ensuring the 4 oil holes in the oil control ring groove are clear.

PISTON RING FITTING

(1) Wipe cylinder bore clean. Insert ring and push down with piston to ensure it is square in bore. The ring gap measurement must be made with the ring positioning at least 12 mm (0.50 in.) from bottom of cylinder bore. Check gap with feeler gauge. Top compression ring gap .25 to .50mm (.0098 to .0196 in.). Second compression ring gap .25 to .35mm (.0098 to .0137 in.). Oil control ring gap .25 to .58mm (.0098 to .0228 in.).

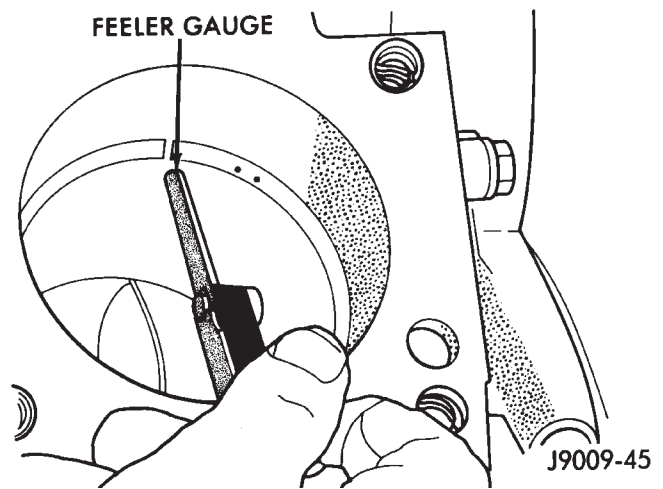

Fig. 97 Ring Gap Measurement

- (2) If ring gaps exceed dimension given, new rings or cylinder liners must be fitted. Keep piston rings in piston sets.
- (3) Check piston ring to groove clearance (Fig. 98). Top compression ring gap .08 to .130mm (.0031 to .0051 in.). Second compression ring gap .070 to .102mm (.0027 to .0040 in.). Oil control ring gap .040 to .072mm (.0015 to .0028 in.).

PISTON RINGS—INSTALLATION

- (1) Install rings on the pistons using a suitable ring expander (Fig. 99).
- (2) Top compression ring is tapered and chromium plated. The second ring is of the scraper type and must be installed with scraping edge facing bottom of the piston. The third is an oil control ring. Ring gaps must be positioned, before inserting piston into the liners, as follows (Fig. 101).
- (3) Top ring gap must be positioned at 30 degrees to the right of the combustion chamber recess (looking at the piston crown from above).

REMOVAL AND INSTALLATION (Continued)

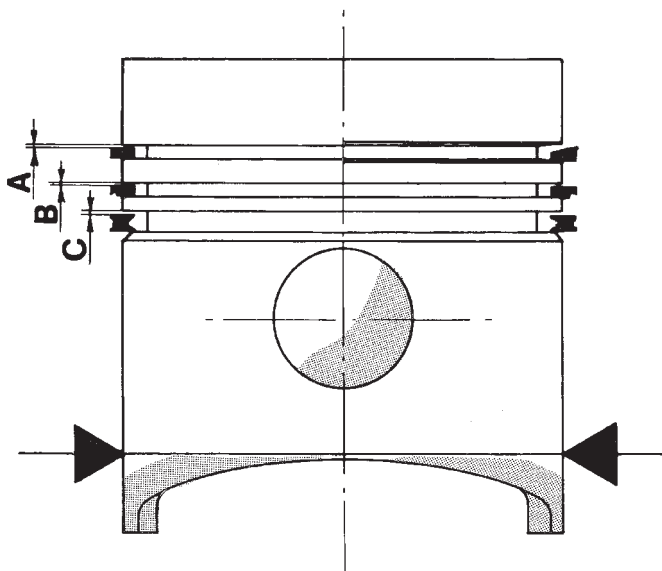

J9509-22

Fig. 98 Piston Ring to Groove Clearance

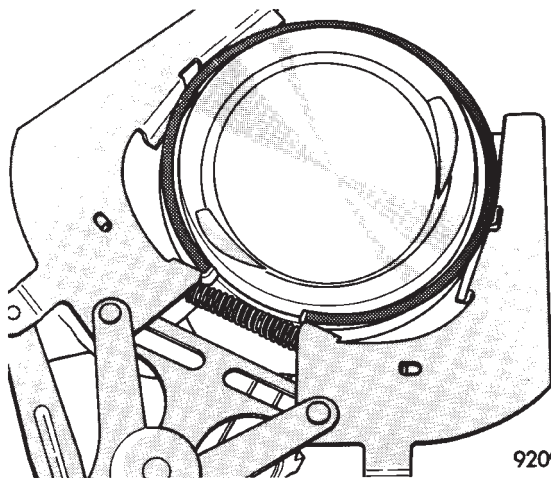

9209-16

Fig. 99 Piston Rings—Removing and Installing

(4) Second piston ring gap should be positioned on the opposite side of the combustion chamber recess.

(5) Oil control ring gap to be located 30 degrees to the left of combustion chamber recess.

(6) When assembling pistons check that components are installed in the same position as before disassembly, determined by the numbers stamped on the crown of individual pistons. Engine cylinders are numbered starting from gear train end of the engine. **Face chamber recess side of piston towards camshaft**. Therefore, the numbers stamped on con rod big end should also face in the same direction. To insert piston into cylinder use a ring compressor as shown in (Fig. 102).

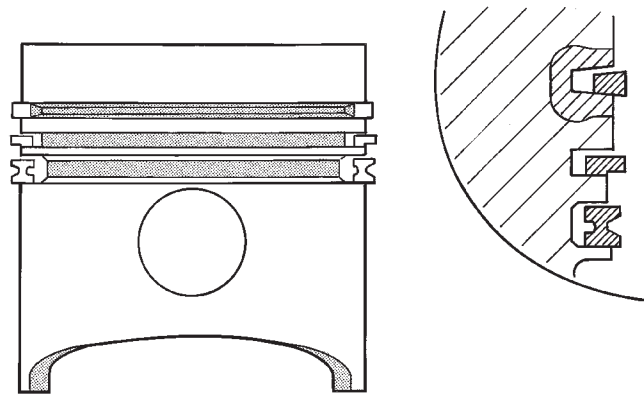

J9509-171

Fig. 100 Piston Ring Identification

PISTON PIN INSTALLATION

- (1) Secure connecting rod in soft jawed vice.
- (2) Lubricate piston pin and piston with clean oil.
- (3) Position piston on connecting rod.

CAUTION: Ensure combustion recess in piston crown and the bearing cap numbers on the connecting rod are on the same side.

- (4) Install piston pin.
- (5) Install clips in piston to retain piston pin.
- (6) Remove connecting rod from vice.

INSTALLATION

(1) Before installing pistons, and connecting rod assemblies into the bore, be sure that compression ring gaps are staggered so that neither is in line with oil ring rail gap (Fig. 101).

- The top piston ring gap must be positioned at 30 degrees to the right of the combustion chamber recess (looking at the piston crown from above).

- The second piston ring gap should be positioned on the opposite side of the combustion chamber recess.

- The piston oil control ring gap is to be located 30 degrees too the left of the combustion chamber recess.

(2) Before installing the ring compressor, make sure the oil ring expander ends are butted and the rail gaps located as shown in (Fig. 101).

(3) Immerse the piston head and rings in clean engine oil, slide the ring compressor, over the piston and tighten with the special wrench (Fig. 102). **Ensure position of rings does not change during this operation.**

(4) Face chamber recess side of piston towards camshaft.

(5) Rotate crankshaft so that the connecting rod journal is on the center of the cylinder bore. Insert

REMOVAL AND INSTALLATION (Continued)

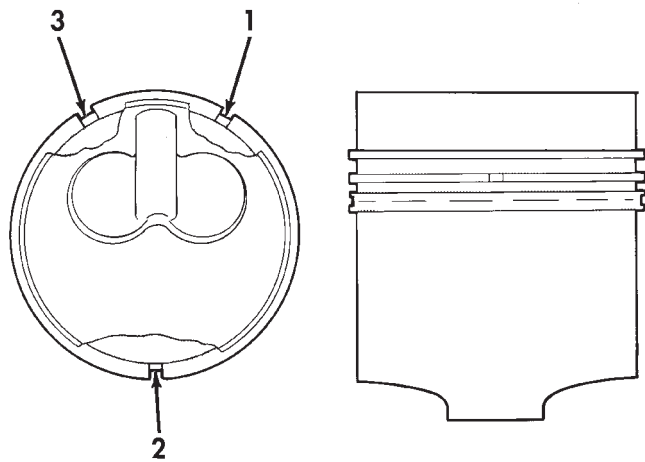

80bce8f2

Fig. 101 Piston Ring Gap Location

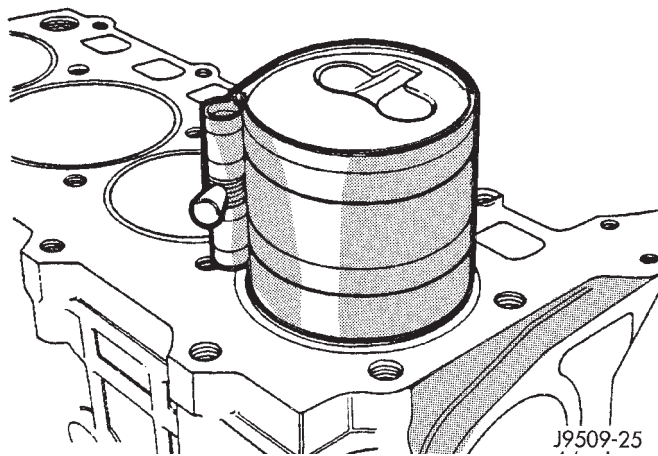

J9509-25

Fig. 102 Installing Piston

rod and piston into cylinder bore and guide rod over the crankshaft journal.

(6) Tap the piston down in cylinder bore, using a hammer handle. At the same time, guide connecting rod into position on connecting rod journal.

(7) Install rod caps. Install cleaned and oiled rod bolts. Torque bolts to 29.5 N·m (22 ft. lb.) plus 60°.

CYLINDER WALL LINER ASSEMBLY

REMOVAL

- (1) Disconnect the negative battery cable
- (2) Remove the engine from vehicle.
- (3) With the engine completely disassembled, install the Cylinder Liner Puller Tool VM-1001 to remove liners (Fig. 103) (Fig. 104).

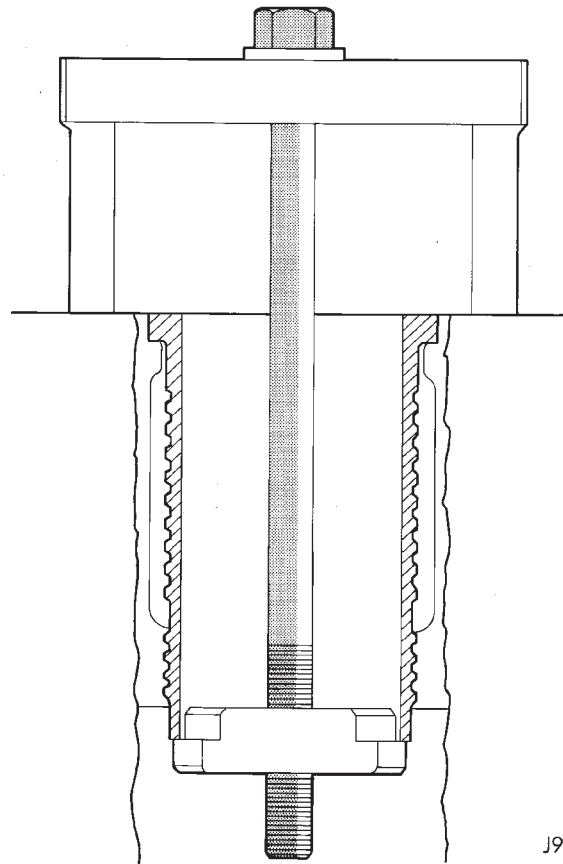

J9509-12

Fig. 103 Liner Removal Tool

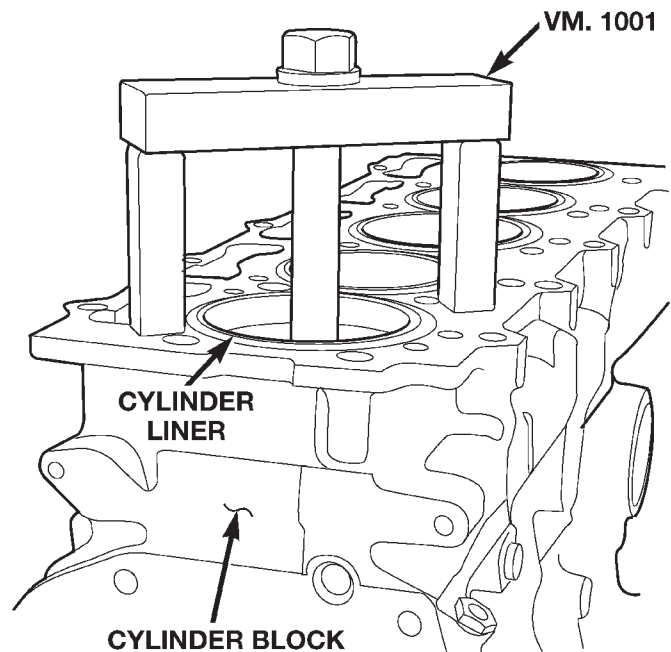

80bc4e4b

Fig. 104 VM.1001

REMOVAL AND INSTALLATION (Continued)

(4) Remove shims from cylinder liner or cylinder block recess. Keep shims with each cylinder liner.

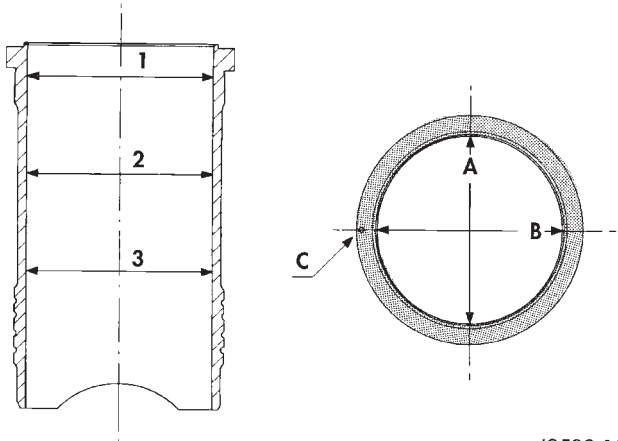

J9509-13

Fig. 105 Liner Inspection

INSTALLATION

(1) Carefully clean residual LOCTITE from liner and crankcase, and degrease the crankcase where it comes into contact with the liners. Install the liners in the crankcase as shown (A), rotating them back and forth by 45° in order to guarantee correct positioning (Fig. 106).

(2) Measure the liner recess relative to block deck with a dial indicator mounted on a special tool VM-1010 A. **All the measurements must be taken on camshaft side**. Zero dial gauge on block deck.

(3) Move dial gauge to cylinder liner record reading on dial gauge.

(4) Remove liner and special tool.

(5) Then select the correct shim thickness to give proper protrusion (0.01 - 0.06 mm).

(6) Fit the shim and the O-rings onto the liner.

(7) Lubricate the lower liner location in the block.

Apply LOCTITE AVX to the corner of the liner seat. Apply LOCTITE AVX uniformly to the upper part of the liner at area.

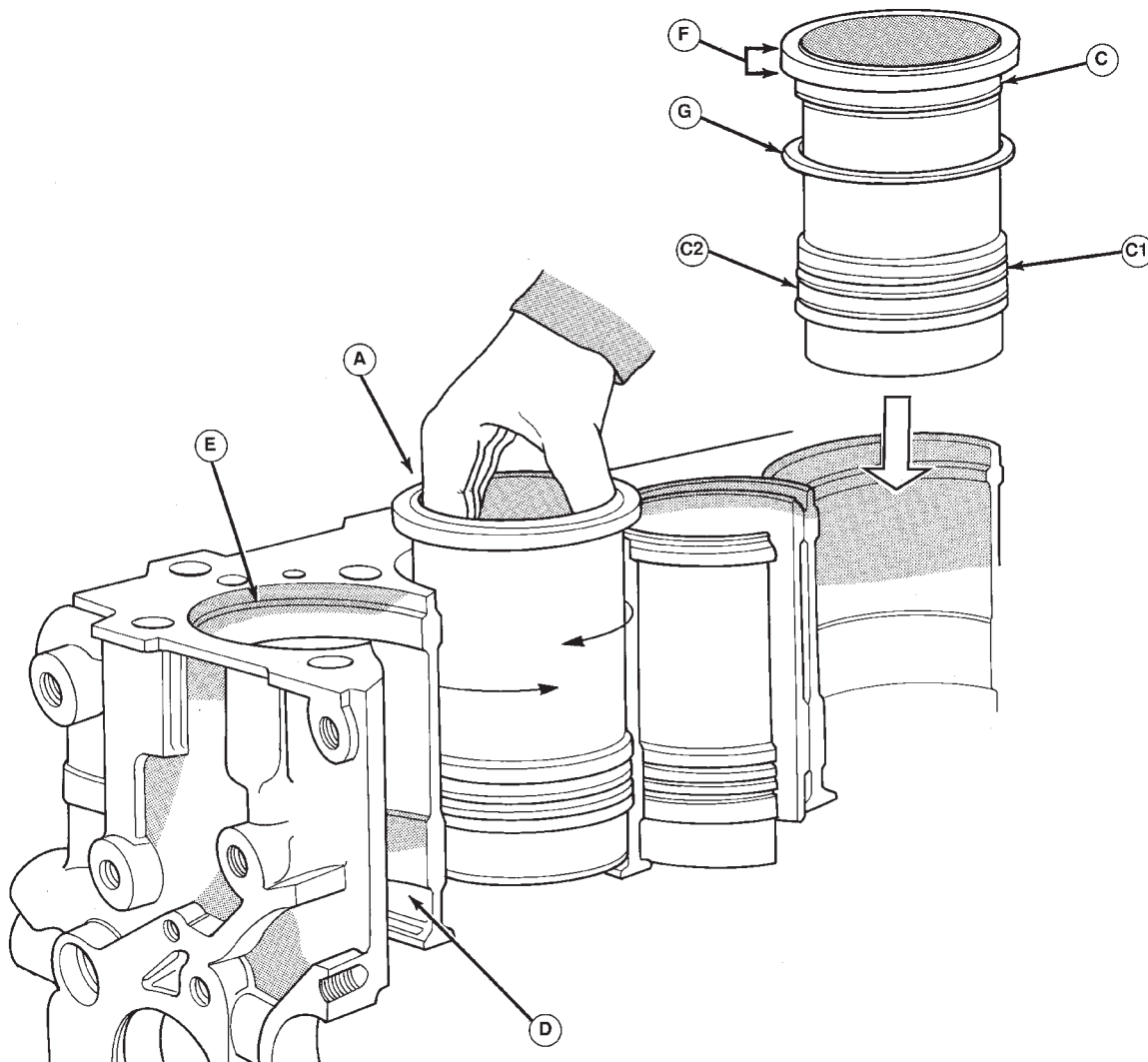

Fig. 106 Liner Installation

J9509-120

REMOVAL AND INSTALLATION (Continued)

(8) Fit the liners in the crankcase making sure that the shim is positioned correctly in the seat. Lock the liners in position using special tool (VM-1016) and bolts (Fig. 107). Clean the residual LOCTITE on the upper surface of the block deck.

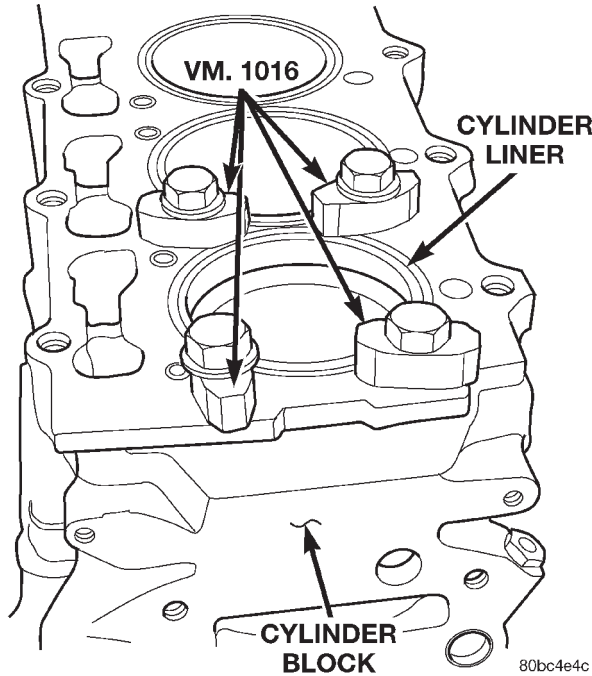

Fig. 107 Liner Clamp Location

(9) Recheck the liner protrusion. It should be 0.01 - 0.06 mm.

NOTE: A period of six hours must elapse between the liners being installed and engine start-up. If engine assembly is not continued after liner installation, the liners need to be clamped for twelve hours minimum.

CRANKSHAFT AND MAIN BEARINGS

REMOVAL

- (1) Disconnect the negative battery cable.
- (2) Remove the engine from vehicle. Refer to engine removal and installation in this section.
- (3) Install the engine on an engine stand.
- (4) Remove the accessory drive system.
- (5) Remove the cylinder head cover. Refer to cylinder head cover removal and installation in this section.
- (6) Remove the rocker arm assemblies and push rods. Refer to rocker arm and push rod removal and installation in this section.
- (7) Remove the intake manifold, exhaust manifold and turbocharger. Refer to Group 11, Exhaust System and Turbocharger.

- (8) Remove the water manifold.
- (9) Remove the oil feed lines to rocker arms.
- (10) Remove the cylinder heads. Refer to cylinder head removal and installation in this section.
- (11) Remove the oil pan and oil pick-up.
- (12) Remove the pistons and connecting rods.
- (13) Remove the vibration damper. Refer to vibration damper removal and installation in this section.
- (14) Remove the timing gear cover. Refer to timing gear cover removal and installation in this section.
- (15) Remove the oil pump and vacuum pump from block.
- (16) Install special tool VM.1004 onto crankshaft over gear (Fig. 108).

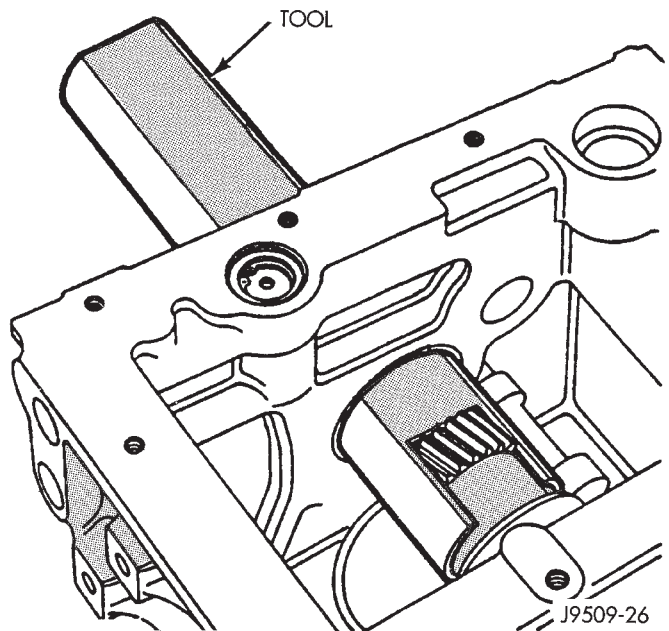
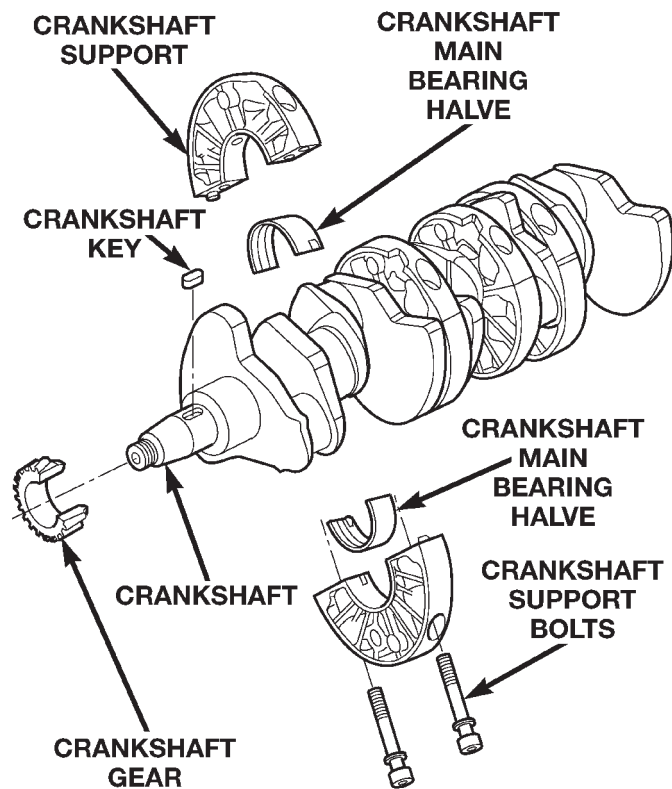

Fig. 108 Crankshaft Special Tool VM.1004

- (17) Remove the main bearing oil feed and crankshaft support locators from block.
- (18) Remove the flywheel and adaptor plate from engine block.
- (19) Remove the thrust bearings from rear main bearing carrier.
- (20) Slide the crankshaft and bearing carriers rearward to rear of cylinder block. Remove crankshaft from the rear of the cylinder block.
- (21) Mark the carriers for assembly and remove the bolts, two for each carrier. Separate the two halves of each carrier, remove from the crankshaft and temporarily re-assemble the carriers (Fig. 109).
- (22) Install the Crankshaft Bearing Remover/Installer VM.1002 on the front main bearing (Fig. 110).
- (23) Using the VM.1002 pull the front main bearing out of the cylinder block (Fig. 110).

REMOVAL AND INSTALLATION (Continued)



80bce8f3

Fig. 109 Crankshaft and Carrier Bearing Assembly

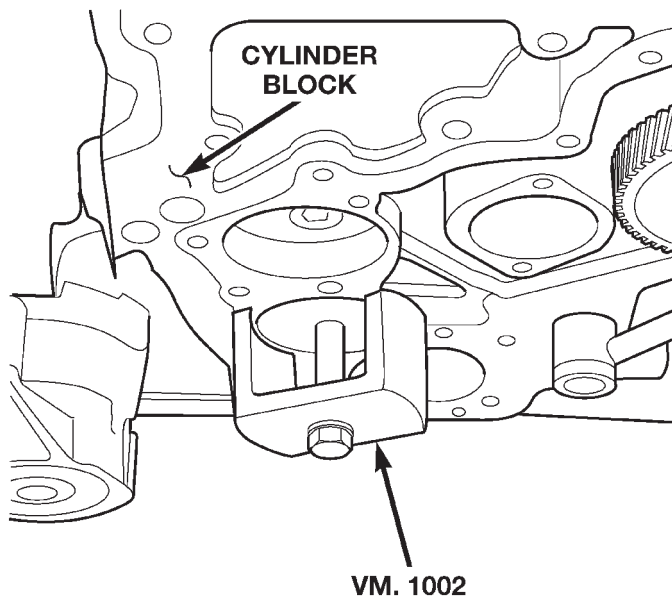

80bc4e4d

Fig. 110 Crankshaft Front Main Bearing Removal

INSTALLATION

NOTE: Be sure that the oil hole in the main bearing lines up with the oil gallery hole in the cylinder block.

(1) Using the VM.1002 push the front main bearing into the cylinder block (Fig. 111).

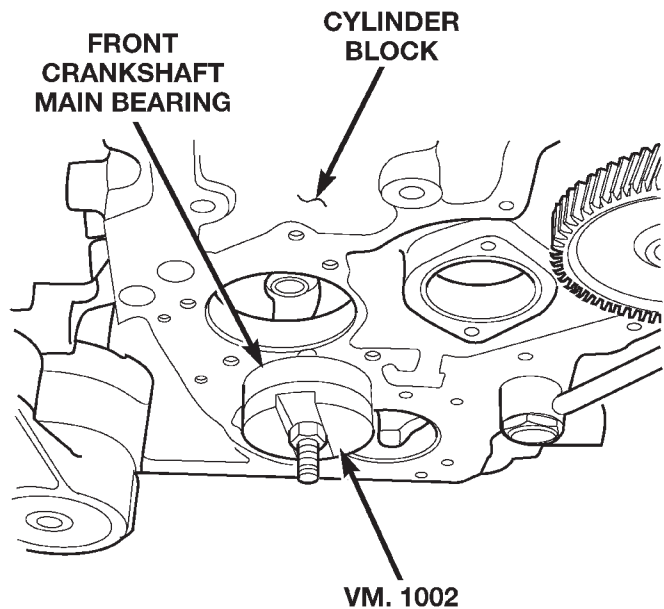

80bc4e4e

Fig. 111 Crankshaft Front Main Bearing Installation

(2) Fit the main bearing supports together. Torque to 44 N·m (32 ft. lbs.)

(3) Check internal diameter of bearings.

(4) If internal diameter of original bearing is being checked and figures are not within specifications, new bearings must be used.

(5) Check the crankshaft main bearing journals to bearing clearances. Clearances of main bearings is .03 to .088mm (.0011 to .0035 in.).

NOTE: Assemble engine according to sequence described, thus saving time and preventing damages to engine components. Clean parts with a suitable solvent and dry them with compressed air before assembly. Use new gaskets where applicable and torque wrenches for correct tightening of components.

(6) Thoroughly clean crankcase and oil passages, and blow dry with compressed air.

(7) Install new main bearing shells in each of the carrier halves. Assemble the carriers to the crankshaft journals, ensuring that the carriers are installed in their original locations. Secure each carrier with the two bolts tightening evenly to 44 N·m (32 ft. lbs.).

REMOVAL AND INSTALLATION (Continued)

(8) Slide special tool VM.1004 over the crankshaft gear and, insert the crankshaft and support assembly into the crankcase in the same manner used for removal.

(9) Align the holes in the lower supports, with the center of the crankcase webs (Fig. 112).

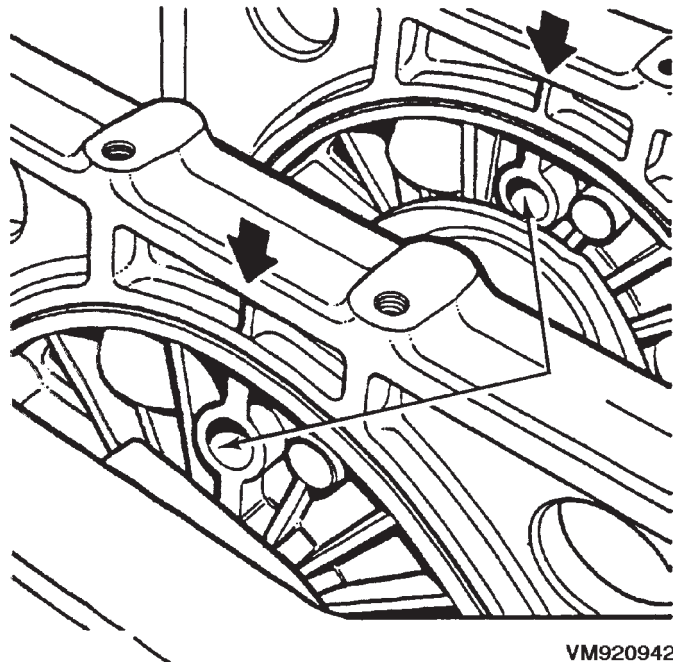

Fig. 112 Main Bearing Support Alignment

(10) Secure each support assembly to the crankcase with the main bearing oil feed and support locators. Torque to 54 N·m (40 ft. lbs.).

(11) Install the rear main bearing support onto crankshaft ensuring arrow on bearing support aligns with vertical web in center of crankcase.

(12) Install the rear oil seal.

(13) Install the new O-rings in adaptor plate.

(14) Install the adaptor plate to block. Torque nuts to 28 N·m (20 ft. lbs.).

(15) Install the Allen bolts through adaptor plate to rear main bearing support. Torque to 11 N·m (97 in. lbs.).

(16) Position the flexplate adapter hub and O-ring on crankshaft and align bolt holes.

NOTE: For purposes of checking crankshaft end play, used adapter hub bolts may be used. Final assembly requires new adapter hub bolts.

(17) Install 2 adapter hub bolts, 180° apart, and tighten bolts to 20 N·m plus 60° (15 ft. lbs.) plus 60°.

(18) Attach dial indicator to engine block.

(19) Move crankshaft toward front of engine and zero indicator.

(20) Move crankshaft toward the rear of engine and record measurement.

(21) Subtract specified crankshaft end play from figure obtained. Crankshaft end play 0.08 to 0.28 mm (.0060 to .0119 in.).

(22) Select thrust washers which will give correct end play.

(23) Remove tools and adapter hub.

(24) Lubricate thrust washer halves and fit them into the rear main bearing carrier.

(25) Ensure that crankshaft end and adapter hub mating surfaces are clean and dry. Install "O" ring in adapter hub groove.

(26) To verify correct end play, install 2 adapter hub bolts 180° apart, and tighten bolts to 20 N·m plus 60° (15 ft. lbs. plus 60°).

(27) Measure crankshaft end play with a dial gauge. Crankshaft end play should not exceed 0.08 to 0.28 mm (.0060 to .0119 in.) (Fig. 113).

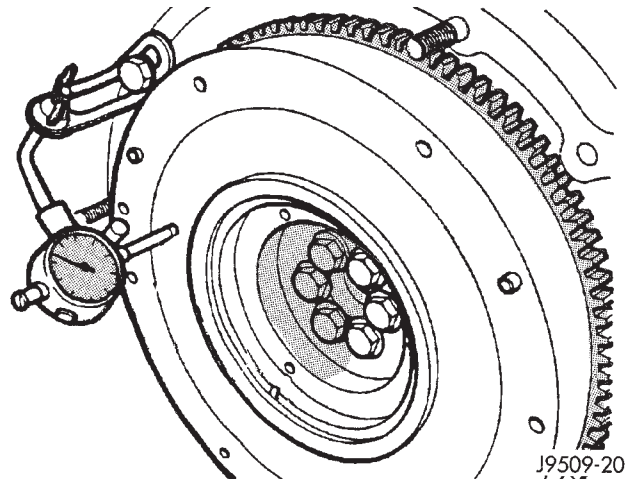

Fig. 113 Measuring Crankshaft End Play

CAUTION: Use NEW adapter hub bolts for the following procedure.

(28) Install a new O-ring on adapter hub. Install adapter hub on crankshaft. The 6 adapter hub bolts must be tightened as follows:

a. Lubricate and install the 6 new adapter hub bolts.

b. Torque the 6 adapter hub bolts to 50 N·m (36 ft. lbs.) starting one bolt and following with the opposite one (cross tightening) until completion, in a clockwise direction..

c. Loosen one bolt at a time and tighten to 20 N·m (14 ft. lbs.) plus 75° using the cross tightening method.

(29) Install the pistons and connecting rod assemblies. Refer to piston and connecting rods removal and installation in this section.

(30) Install the oil pick up tube. Torque bolts to 25 N·m (18 ft. lbs.).

REMOVAL AND INSTALLATION (Continued)

(31) Install the oil pan. Refer to oil pan removal and installation in this section.

(32) Install the vacuum pump, being careful to align the gear timing marks with those on the crankshaft gear. Torque screws to 20 N·m (15 ft. lbs.).

(33) Before installing the oil pump check pump bore depth in block (A) and pump body height (B) (Fig. 114). Difference between A and B should be 0.020-0.082 mm (.0007 to 0032 in.).

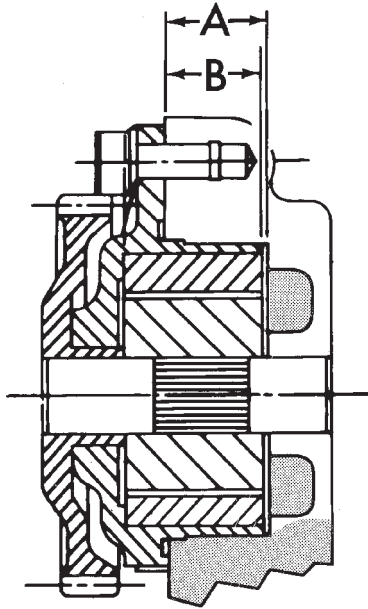

Fig. 114 Oil Pump Bore Depth

(34) Install the oil pump. Torque screws to 27 N·M (20 ft.lbs.). Check for normal backlash between pump and crankshaft gears.

(35) Install the timing gear cover. Refer to timing gear cover removal and installation in this section.

(36) Install the vibration damper. Refer to vibration damper removal and installation in this section.

(37) Install the cylinder heads. Refer to cylinder head removal and installation in this section.

(38) Install the rocker arms and push rods. Refer to rocker arm and push rod removal and installation in this section.

(39) Install the cylinder head cover. Refer to cylinder head cover removal and installation in this section.

(40) Install the accessory drive system.

(41) Install the engine in vehicle. Refer to engine removal and installation in this section.

(42) Fill engine with the correct amount of fluids specified.

(43) Connect the negative battery cable.

DISASSEMBLY AND ASSEMBLY

HYDRAULIC TAPPETS

DISASSEMBLE

- (1) Pry out plunger retainer spring clip.
- (2) Clean varnish deposits from inside of tappet body above plunger cap.
- (3) Invert tappet body and remove plunger cap, plunger, check valve, check valve spring, check valve retainer and plunger spring. Check valve could be flat or ball.

ASSEMBLE

- (1) Clean all tappet parts in a solvent that will remove all varnish and carbon.
- (2) Replace tappets that are unfit for further service with new assemblies.
- (3) If plunger shows signs of scoring or wear, install a new tappet assembly. If valve is pitted, or valve seat on end of plunger is prevented from seating, install a new tappet assembly.
- (4) Assemble tappets.

CLEANING AND INSPECTION

CYLINDER HEAD

CLEANING

Thoroughly clean the engine cylinder head and cylinder block mating surfaces. Clean the intake and exhaust manifold and engine cylinder head mating surfaces. Remove all gasket material and carbon.

Check to ensure that no coolant or foreign material has fallen into the tappet bore area.

Remove the carbon deposits from the combustion chambers and top of the pistons.

INSPECTION

Use a straightedge and feeler gauge to check the flatness of the engine cylinder head and block mating surfaces (Fig. 115).

Minimum cylinder head thickness 89.95mm (3.541 in.)

CAUTION: If only one cylinder head is found to be distorted and requires machining, it will also be necessary to machine the remaining cylinder heads and end plates by a corresponding amount to maintain correct cylinder alignment.

CLEANING AND INSPECTION (Continued)

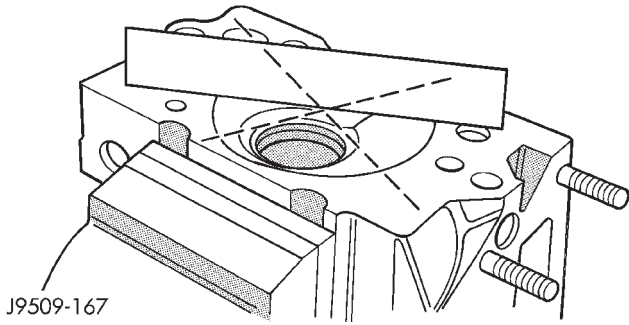

Fig. 115 Checking Cylinder Head Flatness

ROCKER ARMS AND PUSH RODS

CLEANING

Clean all the components (Fig. 116) with cleaning solvent.

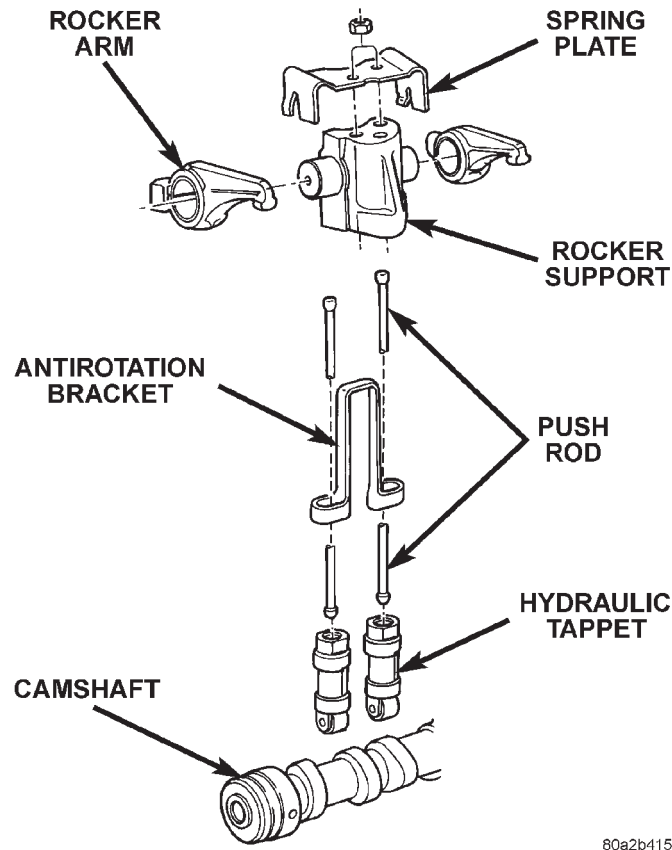

Fig. 116 Rocker Arm Components

Use compressed air to blow out the oil passages in the rocker arms and push rods.

INSPECTION

Inspect the pivot surface area of each rocker arm. Replace any that are scuffed, pitted, cracked or excessively worn.

Inspect the valve stem tip contact surface of each rocker arm and replace any rocker arm that is deeply pitted.

Inspect each push rod end for excessive wear and replace as required. If any push rod is excessively worn because of lack of oil, replace it and inspect the corresponding hydraulic tappet for excessive wear.

Inspect the push rods for straightness by rolling them on a flat surface or by shining a light between the push rod and the flat surface.

A wear pattern along the length of the push rod is not normal. Inspect the engine cylinder head for obstruction if this condition exists.

PISTONS AND CONNECTING ROD ASSEMBLY

INSPECTION—PISTONS

(1) Piston Diameter: Size: 91.93-91.94mm (3.6191-3.6196 in.) Maximum wear limit .05mm (.0019 in.).

(2) Check piston pin bores in piston for roundness. Make 3 checks at 120° intervals. Maximum out of roundness .05mm (.0019in.).

(3) The piston diameter should be measured approximately 15 mm (.590 in.) up from the base.

(4) Skirt wear should not exceed 0.1 mm (.00039 in.).

(5) The clearance between the cylinder liner and piston should not exceed 0.25 mm (.0009 in.).

(6) Make sure the weight of the pistons does not differ by more than 5 g.

INSPECTION—CONNECTING ROD

(1) Assemble bearing shells and bearing caps to their respective connecting rods ensuring that the serrations on the cap and reference marks are aligned.

(2) Tighten bearing cap bolts to 29N·m (21 ft. lbs.) plus 60°.

(3) Check and record internal diameter of crank end of connecting rod.

NOTE: When changing connecting rods, all four must have the same weight and be stamped with the same number. Replacement connecting rods will only be supplied in sets of four.

Connecting rods are supplied in sets of four since they all must be of the same weight category. Max allowable weight difference is 18 gr.

CLEANING AND INSPECTION (Continued)

NOTE: On one side of the big end of the con-rod there is a two-digit number which refers to the weight category. On the other side of the big end there is a four digit number on both the rod and the cap. These numbers must both face the camshaft as well as the recess on the piston crown (Fig. 118). Lightly heat the piston in oven. Insert piston pin in position and secure it with provided snap rings.

The Four digit numbers marked on con rod big end and rod cap must be on the same side as the camshaft (Fig. 118). After having coated threads with Molyguard, tighten con rod bolts to 29 N·m (21 ft. lbs.) plus 60°.

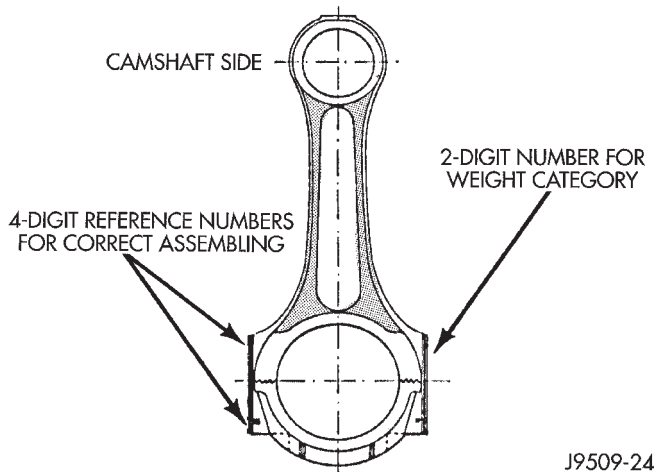

Fig. 117 Connecting Rod Identification

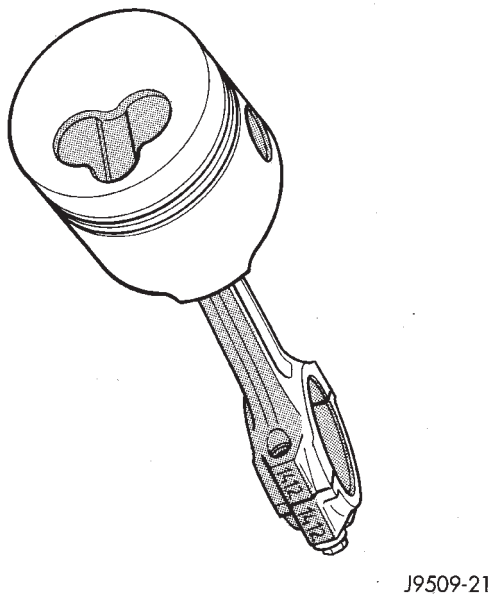

Fig. 118 Piston and Connecting Rod Assembly

INSPECTION—PISTON PIN

(1) Measure the diameter of piston pin in the center and both ends.

(2) Piston pin diameter is 29.990 to 29.996mm (1.1807 to 1.1809 in.).

INSPECTION—CRANKSHAFT JOURNALS

(1) Using a micrometer, measure and record crankshaft connecting rod journals, take reading of each journal 120° apart. Crankshaft journal diameter is 53.84 to 53.955mm (2.1196 to 2.1242 in.).

(2) Crankshaft journals worn beyond limits or show signs of out of roundness must be reground or replaced. Minimum reground diameter is 53.69mm (2.1137 in.).

BEARING-TO-JOURNAL CLEARANCE

Compare internal diameters of connecting rod with crankshaft journal diameter. Maximum clearance between connecting rod and crankshaft journals .022 to .076mm (.0008 to .0029 in.).

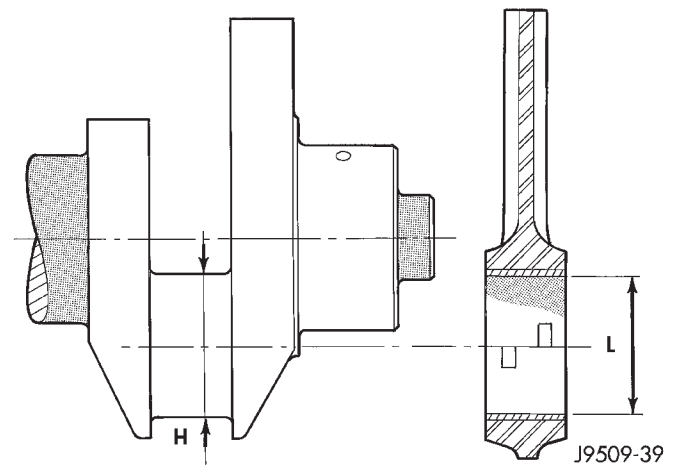

Fig. 119 Bearing Clearance

CYLINDER WALL LINER ASSEMBLY

INSPECTION

The cylinder walls should be checked for out-of-round and taper with dial bore gauge. The cylinder bore out-of-round is 0.100 mm (.0039 inch) maximum and cylinder bore taper is 0.100 mm (0.0039 inch) maximum. If the cylinder walls are badly scuffed or scored, new liners should be installed and honed, and new pistons and rings fitted.

Measure the cylinder bore at three levels in directions A and B (Fig. 120). Top measurement should be 10 mm (3/8 inch) down and bottom measurement should be 10 mm (3/8 inch.) up from bottom of bore.

CLEANING AND INSPECTION (Continued)

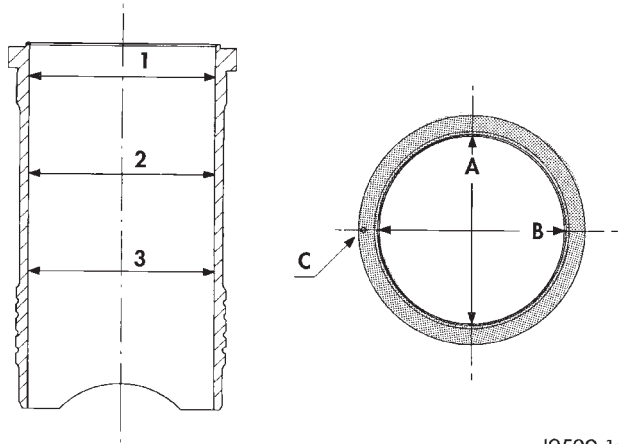

J9509-13

Fig. 120 Liner Inspection

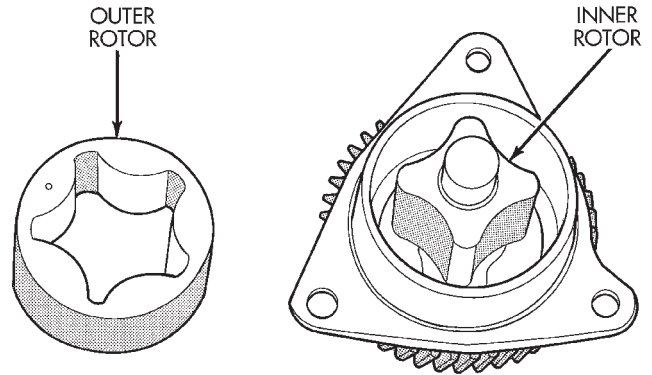

J9509-109

Fig. 122 Oil Pump Inner and Outer Rotors

OIL PUMP

CLEANING

Wash all parts in a suitable solvent and inspect carefully for damage or wear.

INSPECTION

(1) Before installing oil pump check pump bore depth in block (A) and pump body height (B) (Fig. 121). Difference between A and B should be 0.020-0.082 mm.

(2) Check clearance between rotors (Fig. 123).

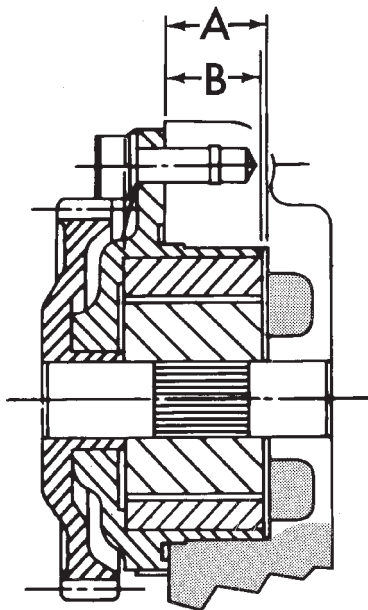

J9509-8

Fig. 121 Oil Pump Bore Depth

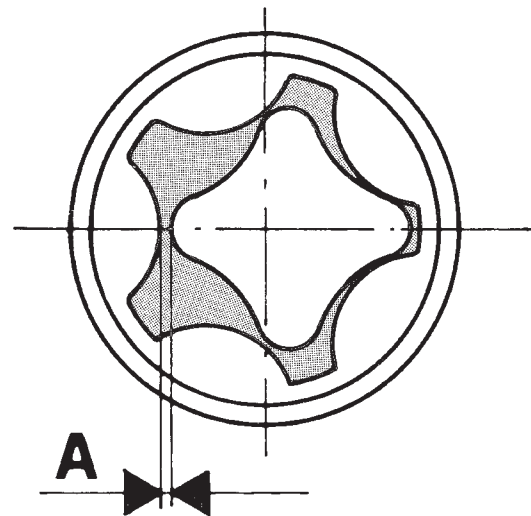

J9509-10

Fig. 123 Checking Rotor Clearance

SPECIFICATIONS

ENGINE SPECIFICATIONS

Description	Specifications
Type	531 CIEW
Number of cylinders	5
Bore	92 mm
Stroke	94 mm
Capacity	3125cc
Injection order	1-2-4-5-3
Compression ratio	21 : 1 (+/- 0.5)
Gasket	Asbestos free

Crankshaft

Front journal diameter	
Nominal	62.985-63.005 mm
-0.25	62.735-62.755 mm
-0.125	62.860-62.880 mm
Front bearing diameter	
Nominal	63.043-63.088 mm
-0.25	62.793-62.838 mm
-0.125	62.918-62.963 mm
Clearance between journal and bearing:	0.038-0.103 mm
Center journal diameter	
Nominal	63.005-63.020 mm
-0.25	62.755-62.770 mm
-0.125	62.880-62.895 mm
Center bearing diameter	
Nominal	63.050-63.093 mm
-0.25	62.800-62.843 mm
-0.125	62.925-62.968 mm
Clearance between journal and bearing:	0.030-0.088
Rear journal diameter	
Nominal	79.980-80.000 mm
-0.25	79.730-79.750 mm
-0.125	79.855-79.875 mm
Rear bearing diameter	
Nominal	80.045-80.070 mm
-0.25	79.795-79.820 mm
-0.125	79.920-79.945 mm
Clearance between journal and bearing:	0.045-0.090
Wear limit:	0.200 mm.
Connecting rod journal	
Nominal	53.940-53.955 mm
-0.25	53.690-53.705 mm
-0.125	53.815-53.830 mm
Connecting rod bearing	
Nominal	53.977-54.016 mm
-0.25	53.727-53.766 mm
-0.125	53.852-53.891 mm
Clearance between journal and bearing:	0.022-0.076
Wear limit:	0.200 mm

Description	Specifications
Crankshaft end play	
End play	0.080-0.280mm
Adjustment	Thrust washers
Thrust washers available:	
	2.31-2.36 mm
	2.41-2.46 mm
	2.51-2.56 mm

Main bearing carriers

Internal diameter	
Front	67.025-67.050 mm
Center	66.670-66.687 mm
Rear	85.985-86.005 mm

Liners

Internal diameter	91.997-92.015 mm
Protrusion	0.01-0.06 mm
Adjustment	Shims
Available shims:	
	0.15 mm
	0.17 mm
	0.20 mm
	0.23 mm
	0.25 mm

Cylinder head

Minimum thickness	89.95-90.05 mm
Gaskets thickness:	
	1.41 mm +/- 0.08, 0 notches
	1.61 mm +/- 0.08, 1 notches
	1.51 mm +/- 0.08, 2 notches
End plates:	
Height	89.92-90.00 mm

Connecting rods

Weight (without the crank bearing):	966 grams
Small end bearing	
Internal diameter	
Minimum	30.035 mm
Maximum	30.050 mm
Crankshaft bearings	
Standard Internal diameter	53.977-54.016 mm

Pistons

Skirt diameter	91.918-91.932 mm
(measured at approximately 10 mm above the bottom of the skirt).	
Piston clearance:	0.065-0.083mm
Top of piston to cylinder head	0.80-0.89 mm
Piston protrusion	0.53 - 0.62 Fit gasket
	Number (1.41), 0 notches
	0.73 - 0.82 Fit gasket
	Number (1.61), 1 notches
	0.63 - 0.72 Fit gasket
	Number (1.51), 2 notches

SPECIFICATIONS (Continued)

Description	Specifications
Piston pins	
Type.....	Fully floating
Pin diameter.....	29.992-29.996 mm
Clearance.....	0.004-0.012 mm
Piston rings	
Clearance in groove:	
Top.....	0.080-0.130 mm
Second.....	0.070-0.110 mm
Oil control.....	0.040-0.080 mm
Fitted gap:	
Top.....	0.30-0.45 mm
Second.....	0.30-0.45 mm
Oil control.....	0.25-0.50 mm
Camshaft	
Journal diameter, front.....	53.495-53.51 mm
Bearing clearance.....	0.030-0.095 mm
Center.....	53.45-53.47 mm
Bearing clearance.....	0.07-0.14 mm
Rear.....	53.48-53.50 mm
Bearing clearance.....	0.04-0.11 mm
Tappets	
Outside diameter.....	22.195-22.212 mm
Rocker gear	
Shaft diameter.....	21.979-22.00 mm
Bush internal diameter.....	22.020-22.041 mm
Assembly clearance.....	0.020-0.062 mm
Valves	
Intake valve:	
Opens.....	26° B.T.D.C.
Closes.....	58° A.B.D.C.
Exhaust valve:	
Opens.....	66° B.B.D.C.
Closes.....	36° A.T.D.C.

Description	Specifications
Face angle:	
Intake.....	55° 30' - 55° 40'
Exhaust.....	45° 25' - 45° 35'
Head diameter:	
Intake.....	40.05-40.25 mm
Exhaust.....	33.8-34.0 mm
Head stand down:	
Intake.....	1.08-1.34 mm
Exhaust.....	0.99-1.25 mm
Stem diameter:	
Intake.....	7.940-7.960 mm
Exhaust.....	7.922-7.940 mm
Clearance in guide:	
Intake.....	0.040-0.075 mm
Exhaust.....	0.060-0.093 mm
Valve guide	
Inside diameter.....	8.0-8.015 mm
Fitted height.....	13.5-14 mm
Valve springs	
Free length.....	44.65 mm
Fitted length.....	38.6 mm
Load at fitted length.....	34 +/- 6% Kg
Load at top of lift.....	92.5 +/- 4% Kg
Number of coils.....	5.33 Valve timing
Lubrication	
System pressure	
at 4000 rev/min.....	3.5 to 5.0 bar (oil at 90-100°C)
Pressure relief valve opens.....	6.84 bar
Pressure relief valve spring - free length.....	57.5 mm
Oil pump:	
Outer rotor end float.....	0.030-0.107 mm
Inner rotor end float.....	0.030-0.107 mm
Outer rotor to body diam. clearance.....	0.130-0.230 mm
Rotor body to drive gear clearance (pump not fitted).....	0.30 - 0.50 mm

SPECIFICATIONS (Continued)

TORQUE SPECIFICATIONS

DESCRIPTION	TORQUE
Adaptor Plate to Block	
Nuts (6)	27 N·m
Automatic Belt Tensioner to Block	
Bolts (2)	120 N·m
Automatic Belt Tensioner to Mounting Bracket	
Bolt (1)	75 N·m
Generator belt	
Tensioner	79 N·m
Generator bracket	
Mounting bolts (10 mm)	47 N·m
Mounting bolts (12 mm)	83 N·m
Generator	
Mounting bolt	47 N·m
Camshaft thrust plate	
Bolts	27 N·m
Connecting rod	
Mounting bolt	29.5 N·m +60°
Crankshaft bearing	
Carrier screw	44 N·m
Crankshaft pulley	
Locknut	196 N·m
Crossmember	
Bolts	42 N·m
Diesel delivery	
Union nut	19 N·m
EGR valve	
To intake manifold	27 N·m
EGR tube	
To EGR valve	26 N·m
Engine mounts	
Engine support bracket	61 N·m
Support Cushion	47 N·m
Support cushion bracket bolts	54 N·m
Support cushion bracket stud nuts	41 N·m
Support Cushion through bolt	65 N·m
Exhaust down pipe	
To turbocharger	32 N·m
Exhaust heat shield	
Screws	11 N·m
Exhaust manifold collar	
Mounting nut	24.5 to 29.5 N·m
Exhaust manifold	
Mounting nut	32 N·m
Fan drive	
To fan hub	56 N·m
Flexplate adapter hub to crankshaft	
Bolts	1st 50 N·m 2nd 20 N·m + 75°
Flexplate to adapter hub	
Bolts	44 N·m
Front timing cover	
Bolts	11 N·m

DESCRIPTION	TORQUE
Fuel filter	
Nuts	28 N·m
Glow plug	
Torque	14 N·m
Idler pulley bracket	
Bolts	40 N·m
Idler pulley	
Bolt (left hand thread)	47 N·m
Injection pump fuel lines	
Nut	23 N·m
Injection pump gear	
Lock nut	86 N·m
Injection pump	
Mounting nut	27.5 N·m
Injector	
Torque	68.5 N·m
Intake manifold	
Mounting nut	32.5 N·m
Main bearing oil delivery	
Union	54 N·m
Water hose to cylinder head	
Nut	8 to 10 N·m
Oil cooler adaptor	
Bolt	60 N·m
Oil feed line	
For rocker arms	12 N·m
To block	27 N·m
To vacuum pump	15 N·m
Oil filter	
Torque	18 N·m
Oil filter adapter	
Torque	46.6 N·m
Oil filter base	
Torque	46.6 N·m
Oil pan	
Mounting bolts	13 N·m
Oil pickup tube	
Torque	25 N·m
Oil pump	
Mounting screw	27 N·m
Oil sump drain plug	
Torque	54 N·m
Power steering pressure hose	
Nut	28 N·m
Power steering pulley	
Nut	130 N·m
Rear crankshaft bearing carrier Allen Bolts	
Torque	11 N·m
Rocker cover	
Bolts	19 N·m
Rocker mounting	
Lock Nut	35 N·m
Steering pump	

SPECIFICATIONS (Continued)

DESCRIPTION	TORQUE
Bolts	28 N·m
Turbocharger	
Mounting nuts	32.5 N·m
Turbocharger	
Oil delivery fitting	27.5 N·m
Turbocharger oil drain	
Plug	10.8 N·m
Vacuum pump	
Torque	27 N·m
Water manifold	
Bolts	12 N·m
Water pump pulley	
Nut	27 N·m

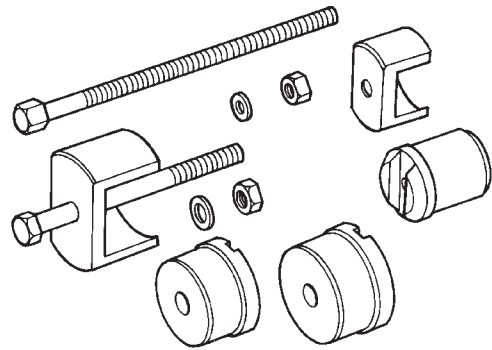

803fd6a3

Crankshaft Bearing Remover/Replacer VM. 1002

SPECIAL TOOLS

SPECIAL TOOLS

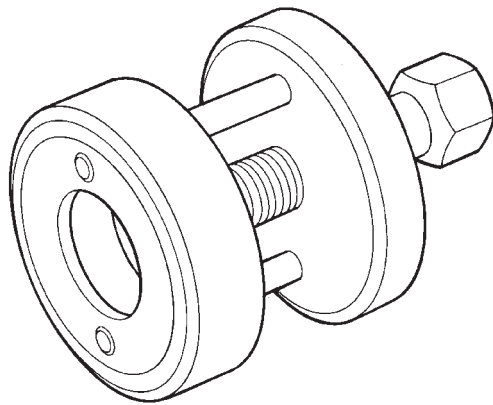

803fd6a1

Crankshaft Pulley and Gear Remover VM. 1000A

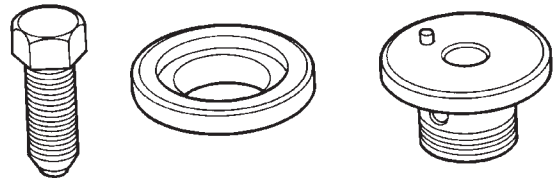

803fd6a4

Injection Pump Puller and Gear retainer VM. 1003

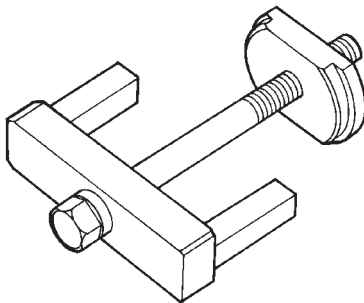

803fd6a2

Cylinder Liner Puller VM, 1001

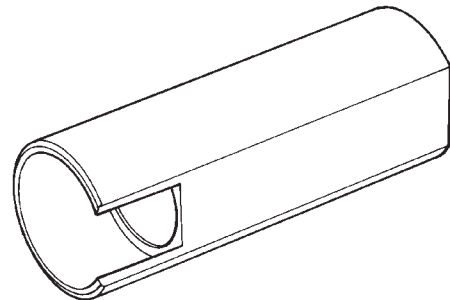

803fd6a5

Crankshaft Remover/Installer Sleeve VM. 1004

SPECIAL TOOLS (Continued)

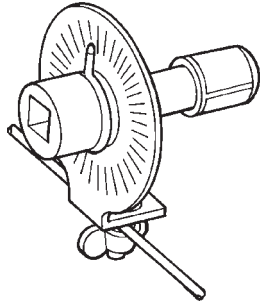

803fd6a6

Torque Angle Gauge VM. 1005

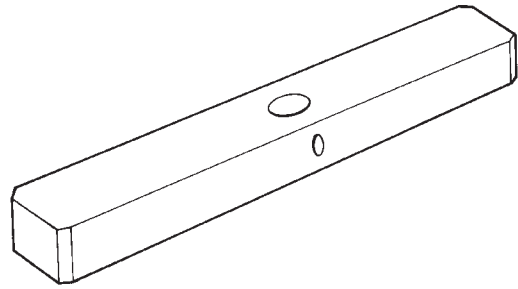

80a1aa43

Cylinder Liner Protrusion Tool VM. 1010

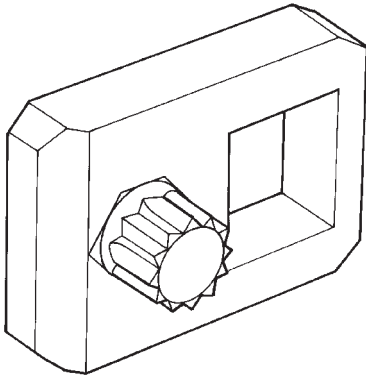

803fd6a7

Cylinder Head Bolt Wrench VM. 1006A

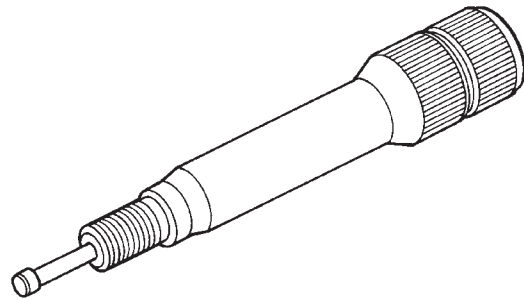

80a1aa44

Bosch Pump Timing Adapter VM. 1011

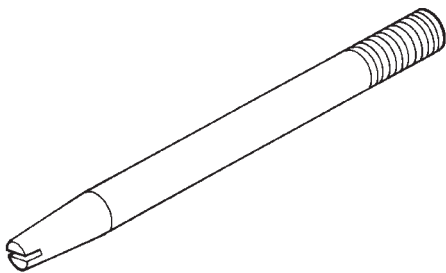

803fd6a9

Cylinder Head Guide Studs VM. 1009

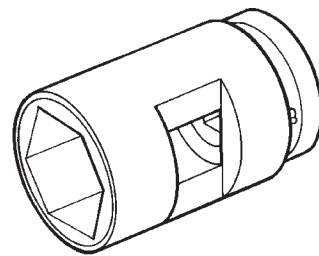

80a1aa45

Injector Remover/Installer Socket VM. 1012

SPECIAL TOOLS (Continued)

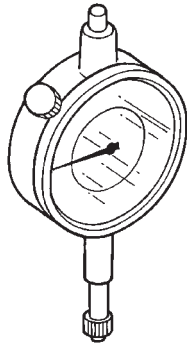

Dial Indicator Gauge VM. 1013

80a1aa46

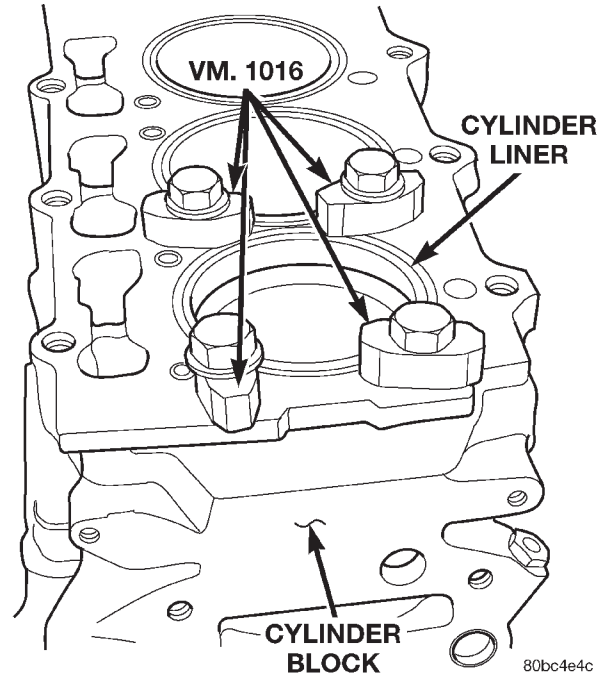

Cylinder Retainer VM. 1016

80bc4e4c

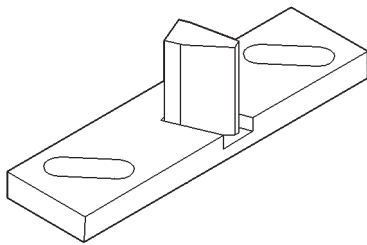

Flywheel Locking Tool VM. 1014

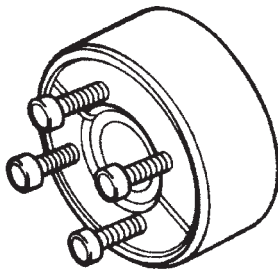

Timing Cover Oil Seal Installer VM. 1015A

80b897ec

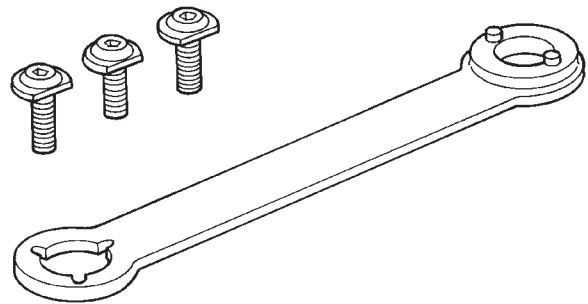

Crankshaft and Water Pump Pulley Holder VM. 1017

80a1aa4a

SPECIAL TOOLS (Continued)

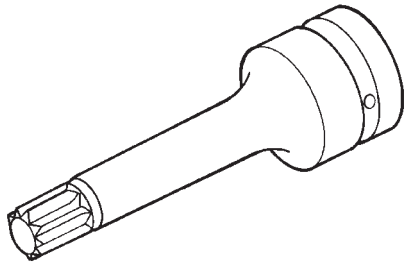

80a1aa4b

Cylinder Head Bolt Wrench M12 VM. 1018

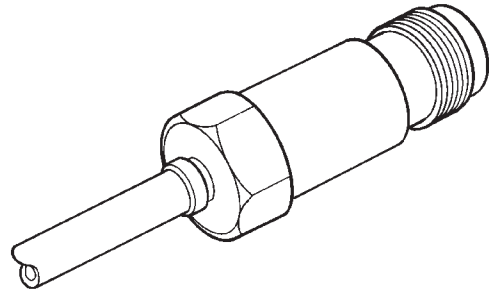

80a1aa4e

Cylinder Leakage Tester Adapter VM. 1021

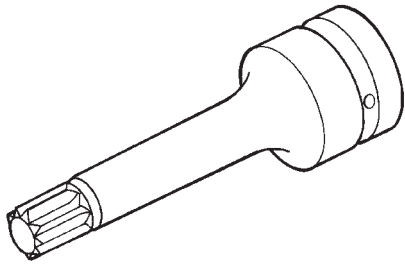

80a1aa4c

Cylinder Head Bolt Wrench M14 VM. 1019

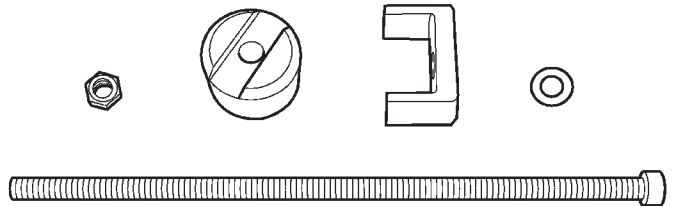

80bc4d03

Fig. 124 Camshaft Bearing Remover/Installer VM. 1040