

FRAME AND BUMPERS

CONTENTS

	page		page
BUMPERS	1	FRAME	4

BUMPERS

INDEX

	page		page
REMOVAL AND INSTALLATION		REAR ABSORBER	3
FRONT ABSORBER	1	REAR FASCIA	2
FRONT FASCIA	1		

REMOVAL AND INSTALLATION

FRONT FASCIA

REMOVAL

- (1) Raise and support vehicle.
- (2) Turn front wheels to access rivets and remove plastic rivets attaching fascia to wheel liner.
- (3) Remove bolts attaching fascia to fender (Fig. 1).
- (4) Remove plastic push pin fasteners attaching front fascia to lower radiator crossmember splash shield (Fig. 2).
- (5) Disengage fog lamp connectors, if equipped.
- (6) Remove screws attaching fascia/grille to upper radiator crossmember (Fig. 3).
- (7) Slide fascia forward to separate from vehicle.

INSTALLATION

- (1) Slide fascia onto vehicle engaging fascia with tabs on bottom of front fenders.
- (2) Install screws attaching fascia/grille to upper radiator crossmember.
- (3) Install bolts attaching fascia to fender.
- (4) Engage fog lamp connectors, if equipped.
- (5) Install plastic rivets attaching fascia to wheel liner.
- (6) Install plastic push pin fasteners attaching front fascia to lower radiator crossmember splash shield.
- (7) Remove supports and lower vehicle.

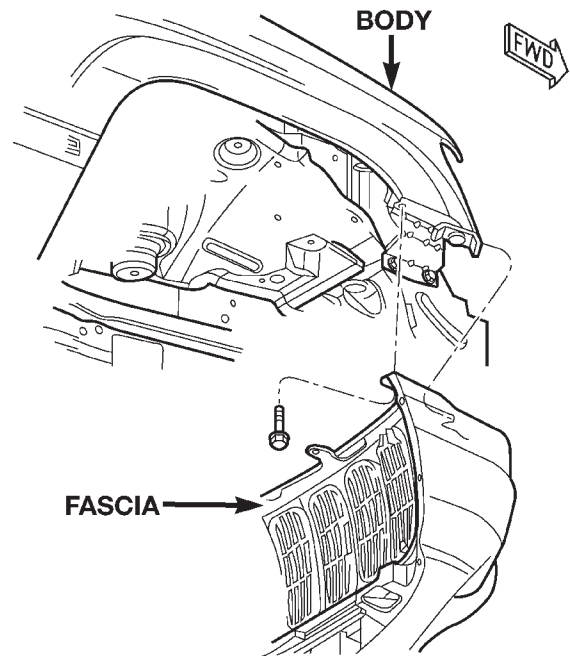

80b46af0

Fig. 1 Front Fascia

FRONT ABSORBER

REMOVAL

- (1) Remove front fascia.
- (2) Remove the retainer attaching the absorber to the fascia.
- (3) Separate the absorber from the fascia.

REMOVAL AND INSTALLATION (Continued)

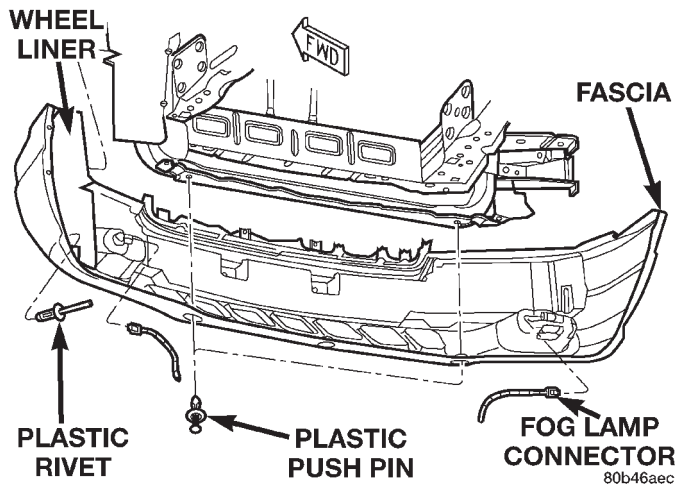

Fig. 2 Front Fascia

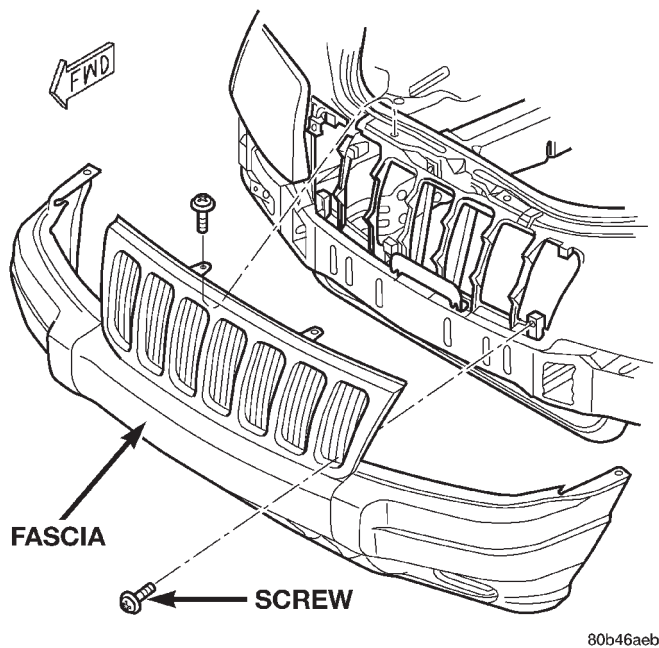

Fig. 3 Front Fascia

INSTALLATION

- (1) Position the absorber on the fascia.
- (2) Install the retainer attaching the absorber to the fascia.
- (3) Install front fascia.

REAR FASCIA

REMOVAL

- (1) Raise and support vehicle.
- (2) Remove tires.
- (3) Remove plastic push pins attaching fascia to fuel tank skid plate.
- (4) Remove plastic rivets attaching fascia to wheel liner.

(5) Remove nuts attaching upper edge of fascia to quarter panel and wheel liner (Fig. 4).

(6) Remove plastic push pins attaching fascia to liftgate opening (Fig. 5).

(7) Remove screws attaching fascia to liftgate opening.

(8) Remove D pillar trim and scuff plate outboard screws.

(9) Remove the rearward tie down screws and the aperture trim panel.

(10) Carefully peel back the rubber body sealer patch to access the retainer clips.

(11) Release the forward and rearward retainer clips on both sides of the fascia.

(12) Grasp forward edges of fascia and pull outward to disengage retainers attaching fascia to quarter panel (Fig. 6).

(13) Separate fascia from vehicle.

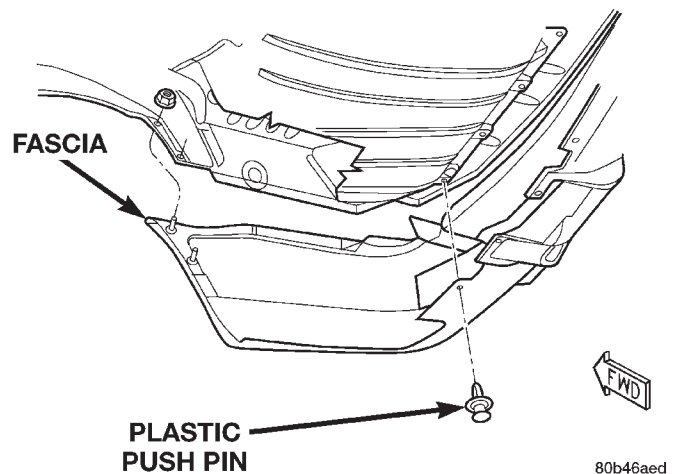

Fig. 4 Rear Fascia Attachment

INSTALLATION

(1) Position fascia on vehicle aligning retainers with slots in quarter panel (Fig. 7).

(2) Press forward edges of fascia inward to engage retainers.

(3) Install screws attaching fascia to liftgate opening.

(4) Install plastic push pins attaching fascia to liftgate opening.

(5) Install nuts attaching upper edge of fascia to quarter panel and wheel liner.

(6) Install plastic rivets attaching fascia to wheel liner.

(7) Install support lower vehicle.

(8) Install plastic push pins attaching fascia to fuel tank skid plate.

(9) Install the interior trim panels removed to access fascia retainers.

(10) Install tie down loop screws.

(11) Install tires.

REMOVAL AND INSTALLATION (Continued)

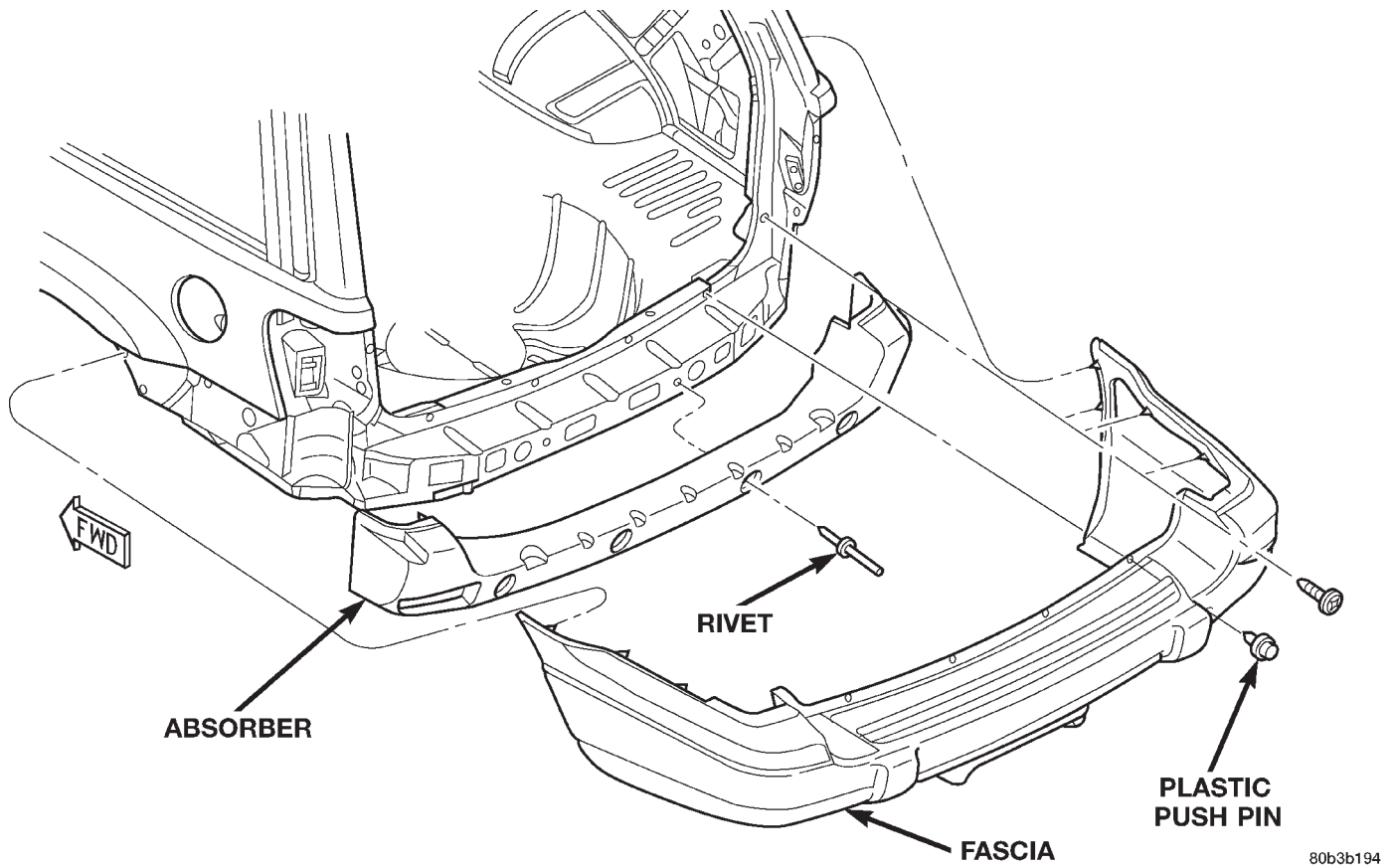

Fig. 5 Rear Fascia

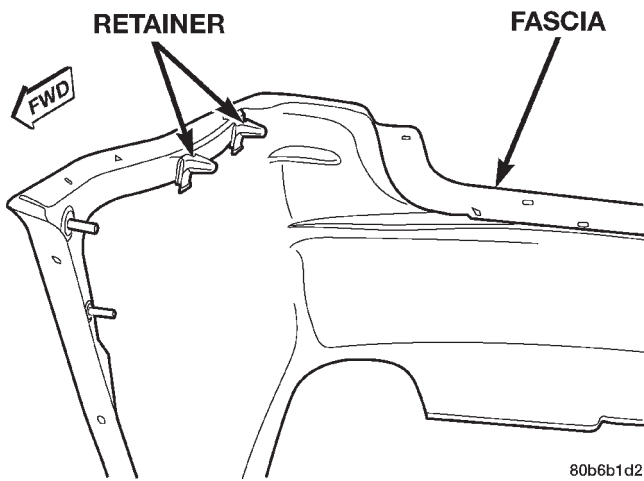

Fig. 6 Rear Fascia Retainers

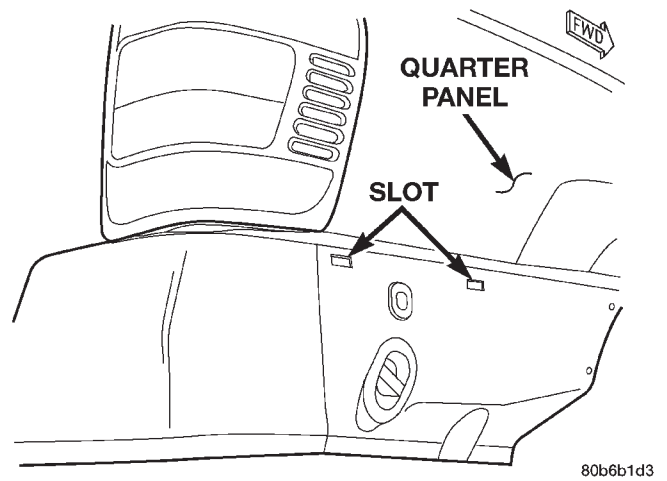

Fig. 7 Fascia Attachment

REAR ABSORBER

REMOVAL

- (1) Remove rear fascia.
- (2) Remove rivets attaching absorber to rear cross-member (Fig. 5).
- (3) Separate absorber from vehicle.

INSTALLATION

- (1) Position absorber on vehicle.
- (2) Install rivets attaching absorber to rear cross-member.
- (3) Install rear fascia.

FRAME

INDEX

	page		page
DESCRIPTION AND OPERATION		REAR TOW HOOK	5
FRAME CONSTRUCTION	4	TRAILER HITCH	5
REMOVAL AND INSTALLATION		TRANSFER CASE SKID PLATE	5
FRONT SKID PLATE	4	SPECIFICATIONS	
FRONT TOW HOOK	4	FRAME DIMENSIONS	6
FUEL TANK SKID PLATE	5	TORQUE SPECIFICATIONS	8

DESCRIPTION AND OPERATION

FRAME CONSTRUCTION

DESCRIPTION

Jeep Grand Cherokee vehicles do not have a conventional frame. They are constructed as a unitized body and frame. Jeep unibodies are constructed from special high-strength steel and coated metals. This process reduces weight and provides strength to withstand the forces applied against structural members. The structural members provide a unibody that has great structural strength.

REMOVAL AND INSTALLATION

FRONT TOW HOOK

REMOVAL

- (1) Remove bolts that attach tow hook bracket to the lower crossmember (Fig. 1).
- (2) Separate tow hook bracket from lower crossmember.

INSTALLATION

- (1) Position tow hook bracket at the lower crossmember.
- (2) Install bolts attaching tow hook bracket to crossmember. Tighten bolts to 54 N·m (40 ft. lbs.) torque.

FRONT SKID PLATE

REMOVAL

- (1) Position a support under skid plate.
- (2) Remove bolts attaching skid plate to frame (Fig. 2).
- (3) Separate skid plate from frame.

INSTALLATION

- (1) Position skid plate on a support.
- (2) Raise it into position

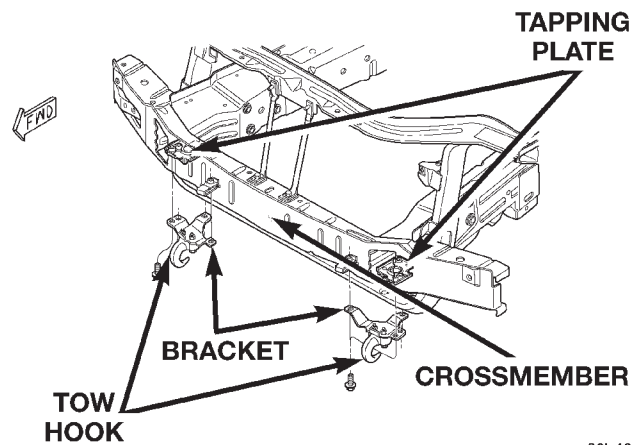

80b46aof

Fig. 1 Front Tow Hook

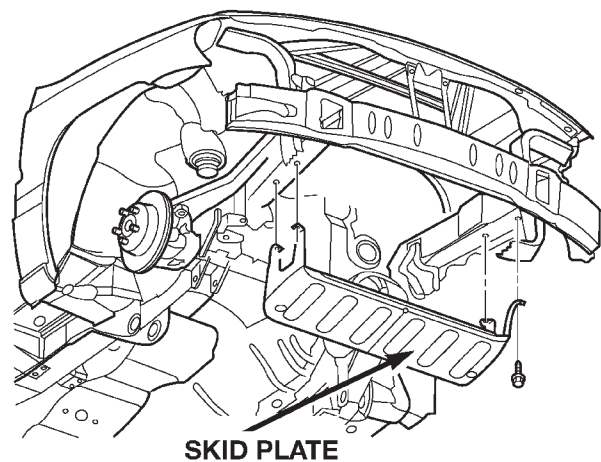

80b46a10

Fig. 2 Front Skid Plate

- (3) Install bolts attaching skid plate to frame. Tighten bolts to 54 N·m (40 ft. lbs.) torque.

REMOVAL AND INSTALLATION (Continued)

TRANSFER CASE SKID PLATE

REMOVAL

- (1) Support skid plate.
- (2) Remove bolts that attach skid plate to transmission support crossmember and frame sill (Fig. 3).
- (3) Remove support and skid plate from vehicle.

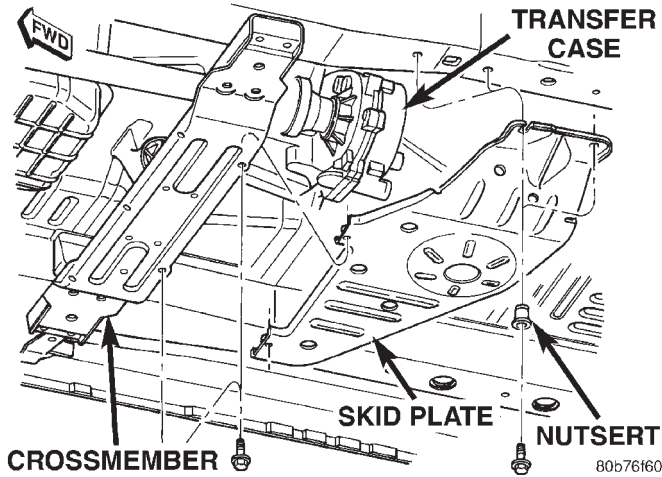

Fig. 3 Transfer Case Skid Plate

INSTALLATION

- (1) Install nutserts, if removed.
- (2) Position and support skid plate at the frame sill and transmission support crossmember.
- (3) Attach skid plate to frame sill and crossmember with the bolts. Tighten bolts to 34 N·m (25 ft. lbs) torque.

FUEL TANK SKID PLATE

The fuel tank skid plate is integrated with the fuel tank. Refer to Fuel Tank for service procedures

REAR TOW HOOK

REMOVAL

- (1) Remove rear tow hook to frame brace.
- (2) Remove bolts attaching the tow hook bracket to frame (Fig. 4).
- (3) Separate tow hook bracket from frame.

INSTALLATION

- (1) position tow hook bracket on frame.
- (2) Install bolts attaching tow hook bracket to frame. Tighten bolts to 68 N·m (50 ft. lbs.) torque.
- (3) Install rear tow hook to frame brace.

TRAILER HITCH

REMOVAL

- (1) Raise and support vehicle.
- (2) Remove rear fascia.

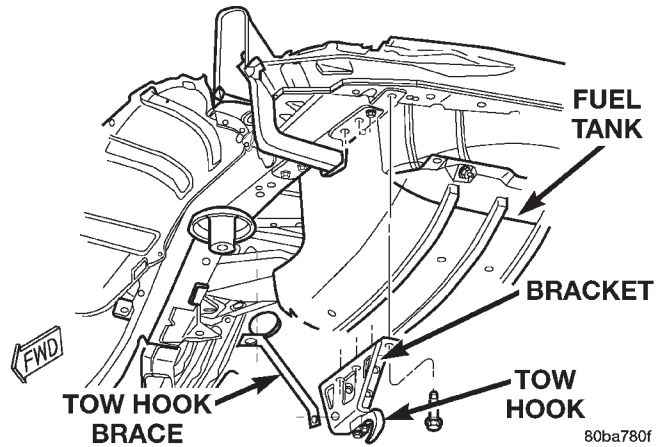

Fig. 4 Rear Tow Hook

- (3) Remove screws attaching trailer harness plug to trailer hitch.
- (4) Disconnect harness connector from harness plug.
- (5) Position support stands under trailer hitch.
- (6) Remove bolts attaching trailer hitch to frame rails (Fig. 5).
- (7) Separate trailer hitch from vehicle.

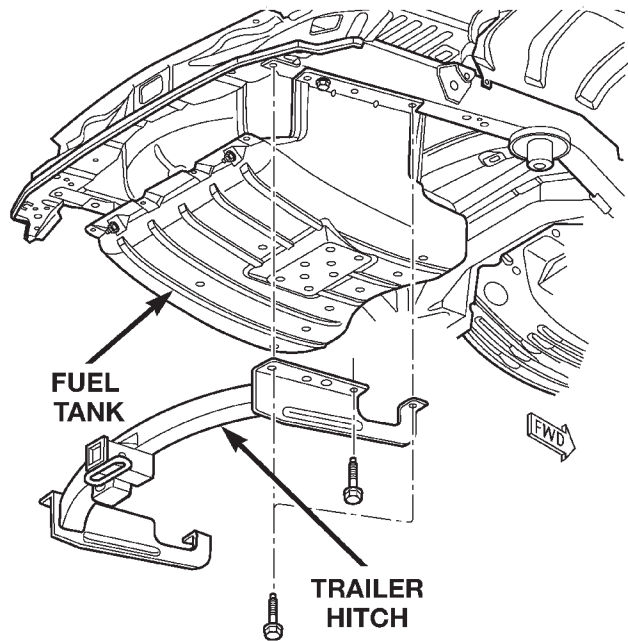
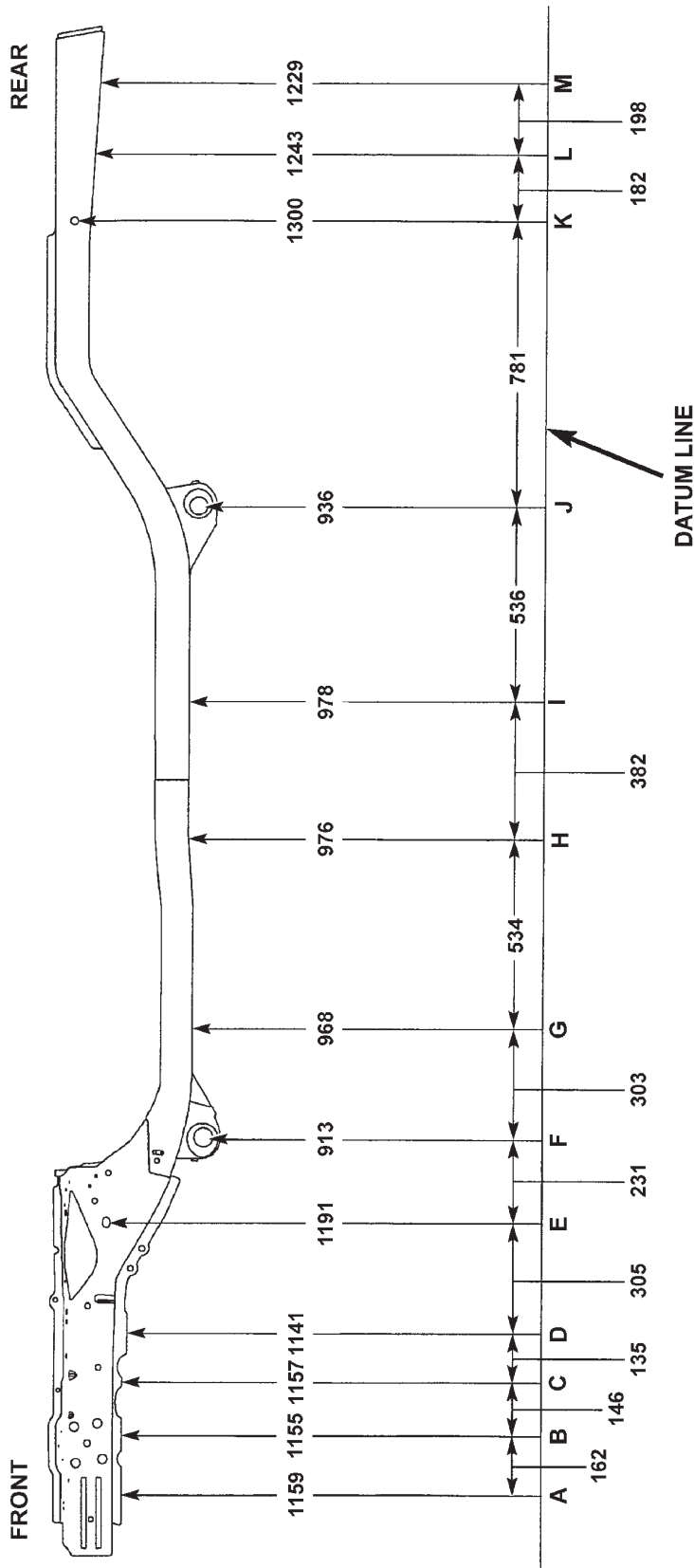

Fig. 5 Trailer Hitch

INSTALLATION

- (1) Position trailer hitch on support stands.
- (2) Position trailer hitch on vehicle.
- (3) Install bolts attaching trailer hitch to frame rails. Tighten bolts to 68 N·m (50 lbs.) torque.
- (4) Connect harness connector to harness plug.
- (5) Position harness plug in trailer hitch and install screws.
- (6) Install rear fascia.
- (7) Remove supports and lower vehicle.

SPECIFICATIONS
 FRAME DIMENSIONS
 SIDE VIEW



SIDE VIEW

DATUM HEIGHT DIMENSIONS ARE PERPENDICULAR TO DATUM PLANE.
 DATUM LENGTH DIMENSIONS ARE PARALLEL TO CENTERLINE OF VEHICLE,
 AND ARE MEASURED CENTER-TO-CENTER.

ALL MEASUREMENTS ARE IN MILLIMETERS

80b6feba

SPECIFICATIONS (Continued)

BOTTOM VIEW

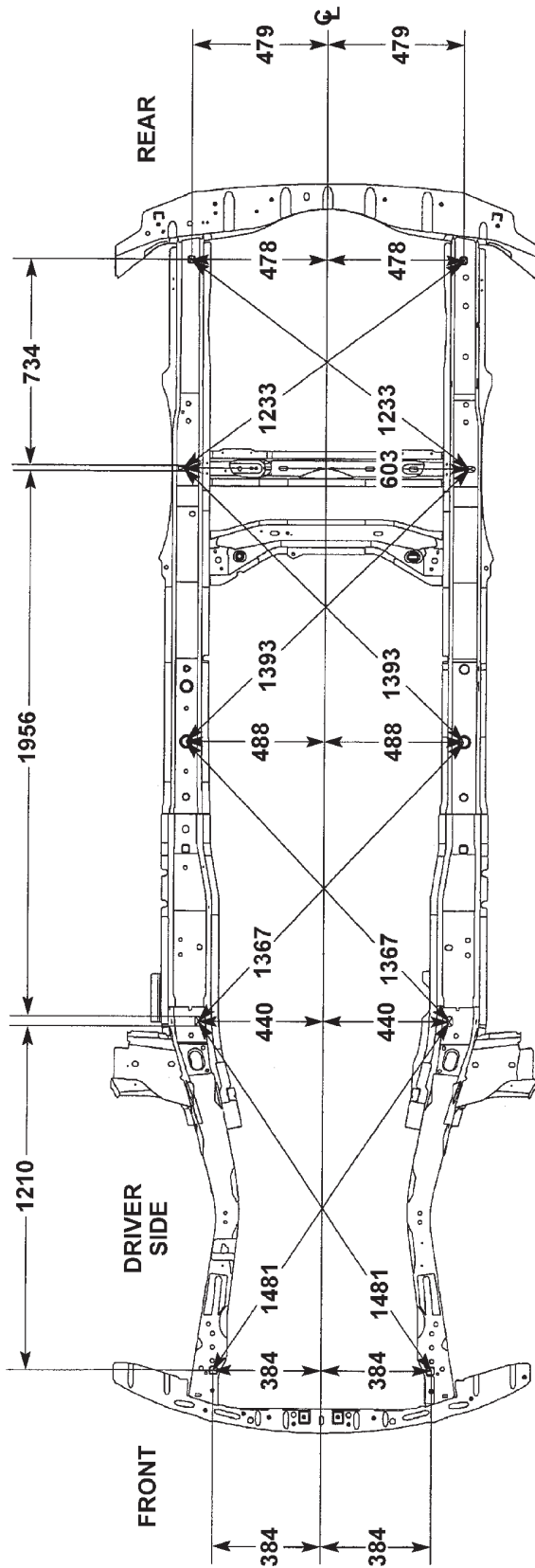

BOTTOM VIEW

BOTTOM VIEW POINT-TO-POINT DIMENSIONS ARE TAKEN WITH TRAM BAR POINTERS SET AT EQUAL LENGTHS. BOLTS AND STUDS ARE MEASURED TO CENTER. HOLES ARE MEASURED TO CLOSEST EDGE.

ALL MEASUREMENTS ARE IN MILLIMETERS

80b6f6bb

SPECIFICATIONS (Continued)

TORQUE SPECIFICATIONS

DESCRIPTION	TORQUE
Front Tow Hook Bolt	54 N·m (40 ft. lbs.)
Front Skid Plate Bolt	54 N·m (40 ft. lbs.)
Rear Tow Hook Bolt	68 N·m (50 ft. lbs.)
Trailer Hitch Bolts	68 N·m (50 ft. lbs.)
Transfer Case Skid Plate Bolts . .	34 N·m (25ft. lbs.)