

HEATING AND AIR CONDITIONING

CONTENTS

	page		page
DESCRIPTION AND OPERATION		COMPRESSOR CLUTCH RELAY	
A/C APPLICATION TABLE	2	HEATER PERFORMANCE	29
ACCUMULATOR	2	HIGH PRESSURE SWITCH	30
BLOWER MOTOR	2	LOW PRESSURE SWITCH	30
BLOWER MOTOR CONTROLLER	3	REFRIGERANT SYSTEM LEAKS	30
BLOWER MOTOR RESISTOR	3	SERVICE PROCEDURES	
BLOWER MOTOR SWITCH	3	REFRIGERANT OIL LEVEL	31
COMPRESSOR	4	REFRIGERANT RECOVERY	32
COMPRESSOR CLUTCH	4	REFRIGERANT SYSTEM CHARGE	32
COMPRESSOR CLUTCH RELAY	4	REFRIGERANT SYSTEM EVACUATE	33
CONDENSER	4	REMOVAL AND INSTALLATION	
EVAPORATOR COIL	5	ACCUMULATOR	34
HEATER AND AIR CONDITIONER	5	BLEND-AIR DOOR(S)	35
HEATER AND AIR CONDITIONER CONTROL	6	BLOWER MOTOR	38
HEATER CORE	5	BLOWER MOTOR RESISTOR AND CONTROLLER	38
HIGH PRESSURE RELIEF VALVE	6	COMPRESSOR	39
HIGH PRESSURE SWITCH	7	COMPRESSOR CLUTCH	40
INFRARED TEMPERATURE SENSOR	7	COMPRESSOR CLUTCH RELAY	42
LOW PRESSURE SWITCH	7	CONDENSER	42
REFRIGERANT	7	DISCHARGE LINE	43
REFRIGERANT LINES	8	DUCTS AND OUTLETS	44
REFRIGERANT OIL	8	EVAPORATOR COIL	46
REFRIGERANT SYSTEM SERVICE EQUIPMENT	8	HEAT/DEFROST DOOR	46
REFRIGERANT SYSTEM SERVICE PORT	9	HEATER CORE AND TUBES	50
SERVICE WARNINGS AND PRECAUTIONS	9	HEATER-A/C CONTROL	48
VACUUM CHECK VALVE	11	HEATER-A/C HOUSING	48
VACUUM RESERVOIR	11	HIGH PRESSURE RELIEF VALVE	51
VACUUM SYSTEM	11	HIGH PRESSURE SWITCH	52
VARIABLE ORIFICE VALVE	13	LIQUID LINE	52
DIAGNOSIS AND TESTING		LOW PRESSURE CYCLING CLUTCH SWITCH	53
A/C PERFORMANCE	13	MODE DOOR ACTUATORS	53
AUTOMATIC ZONE CONTROL SYSTEM	17	PANEL OUTLET DOOR	56
BLOWER MOTOR	26	PANEL/DEFROST DOOR AND LEVER	56
BLOWER MOTOR RESISTOR	27	RECIRCULATION AIR DOOR	57
BLOWER MOTOR SWITCH	27	VACUUM CHECK VALVE	58
COMPRESSOR	28	VACUUM RESERVOIR	58
COMPRESSOR CLUTCH COIL	28	VARIABLE ORIFICE VALVE	58

DESCRIPTION AND OPERATION

A/C APPLICATION TABLE

Item	Description	Notes
VEHICLE	WJ Grand Cherokee	
SYSTEM	R134a w/variable orifice tube	
COMPRESSOR	Nippondenso 10PA17	ND-8 PAG oil
Freeze-up Control	Low Pressure Cycling Cutout Switch	accumulator mounted
Low psi Control	opens < 25 psi - resets > 34-38 psi	
High psi Control	opens > 450-490 psi - resets < 270-330 psi	line mounted
CONTROL HEAD	manual type	manual controls
	Automatic Zone Control (AZC)	Automatic Zone Control (AZC) with dual infrared sensing
Mode Doors	vacuum actuators	(electric actuator AZC)
Blend Air Door	electric actuator	(manual and AZC)
Blend Air Door (passenger)	electric actuator	(AZC only)
Fresh/Recirc door	vacuum	(electric actuator AZC)
Blower Motor	hardwired to control head	resistor block manual, power module (AZC)
COOLING FAN	Hybrid - viscous clutch/electric	PCM output
CLUTCH		
Control	relay	PCM
Draw	2.0-3.9 amps @ 12 V	± 0.5V @ 70° F
Gap	0.016"-0.031"	
DRB III®		
Reads	TPS, RPM, A/C switch	
Actuators	clutch relay	

ACCUMULATOR

The accumulator is mounted in the engine compartment between the evaporator coil outlet tube and the compressor inlet. Refrigerant enters the accumulator canister as a low pressure vapor through the inlet tube.

Any liquid, oil-laden refrigerant falls to the bottom of the canister, which acts as a separator. A desiccant bag is mounted inside the accumulator canister to absorb any moisture which may have entered and become trapped within the refrigerant system (Fig. 1).

BLOWER MOTOR

The blower motor and blower wheel are located in the passenger side end of the heater-A/C housing, below the glove box module. The blower motor controls the velocity of the air flowing through the heat-

er-A/C housing by spinning a squirrel cage-type blower wheel within the housing at the selected speed. The blower motor and blower wheel can be serviced from the passenger compartment side of the housing.

The blower motor will only operate when the ignition switch is in the On position, and the heater-A/C mode control switch is in any position, except Off. The blower motor circuit is protected by a fuse in the junction block. On models with the standard manual temperature control system, the blower motor speed is controlled by regulating the battery feed through the blower motor switch and the blower motor resistor. On models with the optional Automatic Zone Control (AZC) system, the blower motor speed is controlled by using Pulse Width Modulation (PWM). The power module adjusts the battery feed voltage to the blower motor, based upon an input from the blower

DESCRIPTION AND OPERATION (Continued)

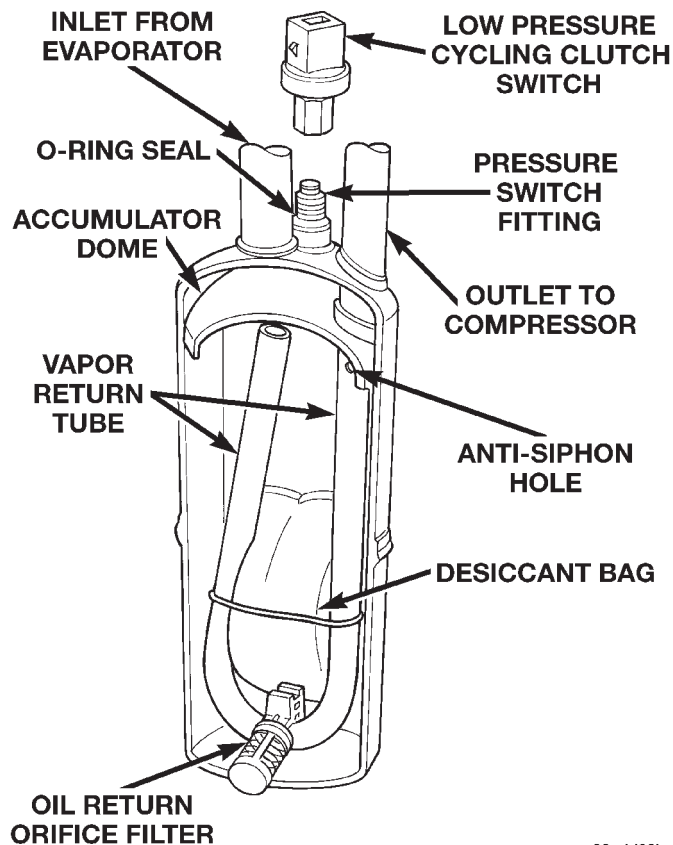

Fig. 1 Accumulator - Typical

motor switch, through the AZC control module. Pulse width modulation of blower power allows the blower to operate at any speed from stationary, to full speed.

The blower motor and blower motor wheel cannot be repaired, and if faulty or damaged, they must be replaced. The blower motor and blower wheel are each serviced separately.

BLOWER MOTOR CONTROLLER

Models equipped with the optional Automatic Zone Control (AZC) system have a blower motor controller (power module). The controller allows the selection of almost infinitely variable blower motor speeds. The controller is mounted to the heater-A/C housing, under the instrument panel and just inboard of the blower motor, in the same location used for the blower motor resistor on manual temperature control systems. It can be accessed without removing any other components.

The blower motor controller output to the blower motor can be adjusted by the blower motor speed switch knob on the AZC heater-A/C control panel, or it can be adjusted automatically by the logic circuitry and programming of the AZC control module. In either case, the AZC control module sends the correct pulse width modulated signal to the power module to

obtain the selected or programmed blower motor speed.

The blower motor controller cannot be repaired and, if faulty or damaged, it must be replaced.

BLOWER MOTOR RESISTOR

Models with the standard manual temperature control system have a blower motor resistor. The blower motor resistor is mounted to the bottom of the heater-A/C housing, under the instrument panel and just inboard of the blower motor. It can be accessed for service without removing any other components.

The resistor has multiple resistor wires, each of which will reduce the current flow to the blower motor to change the blower motor speed by changing the resistance in the blower motor ground path. The blower motor switch directs the ground path through the correct resistor wire to obtain the selected speed.

With the blower motor switch in the lowest speed position, the ground path for the motor is applied through all of the resistor wires. Each higher speed selected with the blower motor switch applies the blower motor ground path through fewer of the resistor wires, increasing the blower motor speed. When the blower motor switch is in the highest speed position, the blower motor resistor is bypassed and the blower motor receives a direct path to ground.

The blower motor resistor cannot be repaired and, if faulty or damaged, it must be replaced.

BLOWER MOTOR SWITCH

The heater-A/C blower motor is controlled by a rotary-type blower motor switch, mounted in the heater-A/C control panel. On vehicles with manual temperature control systems, the switch allows the selection of four blower motor speeds, but will only operate with the ignition switch in the On position and the heater-A/C mode control switch in any position, except Off. On vehicles with the Automatic Zone Control (AZC) systems, the switch allows the selection of Lo Auto, Hi Auto, and an infinite number of manual speed settings between Lo and Hi.

On manual temperature control systems, the blower motor switch is connected in series with the blower motor ground path through the heater-A/C mode control switch. The blower motor switch directs this ground path to the blower motor through the blower motor resistor wires, or directly to the blower motor, as required to achieve the selected blower motor speed.

On AZC systems, the blower motor switch is just one of many inputs to the AZC control module. In the manual blower modes, the AZC control module adjusts the blower motor speed through the blower motor power module as required to achieve the selected blower switch position. In the auto blower

DESCRIPTION AND OPERATION (Continued)

modes, the AZC controller is programmed to select and adjust the blower motor speed through the blower motor power module as required to achieve and maintain the selected comfort level.

The blower motor switch cannot be repaired and, if faulty or damaged, it must be replaced. The switch is serviced only as a part of the heater-A/C control assembly.

COMPRESSOR

The air conditioning system uses a Nippondenso 10PA17 ten cylinder, double-acting swash plate-type compressor on all models. This compressor has a fixed displacement of 170 cubic centimeters (10.374 cubic inches), and has both the suction and discharge ports located on the cylinder head. A label identifying the use of R-134a refrigerant is located on the compressor.

The compressor is driven by the engine through an electric clutch, drive pulley and belt arrangement. The compressor is lubricated by refrigerant oil that is circulated throughout the refrigerant system with the refrigerant.

The compressor draws in low-pressure refrigerant vapor from the evaporator through its suction port. It then compresses the refrigerant into a high-pressure, high-temperature refrigerant vapor, which is then pumped to the condenser through the compressor discharge port.

The compressor cannot be repaired. If faulty or damaged, the entire compressor assembly must be replaced. The compressor clutch, pulley and clutch coil are available for service.

COMPRESSOR CLUTCH

The compressor clutch assembly consists of a stationary electromagnetic coil, a hub bearing and pulley assembly, and a clutch plate (Fig. 2). The electromagnetic coil unit and the hub bearing and pulley assembly are each retained on the nose of the compressor front housing with snap rings. The clutch plate is keyed to the compressor shaft and secured with a screw.

These components provide the means to engage and disengage the compressor from the engine serpentine accessory drive belt. When the clutch coil is energized, it magnetically draws the clutch into contact with the pulley and drives the compressor shaft. When the coil is not energized, the pulley freewheels on the clutch hub bearing, which is part of the pulley. The compressor clutch and coil are the only serviced parts on the compressor.

The compressor clutch engagement is controlled by several components: the A/C switch on the heater-A/C control panel, the Automatic Zone Control (AZC) control module (if the vehicle is so equipped), the low

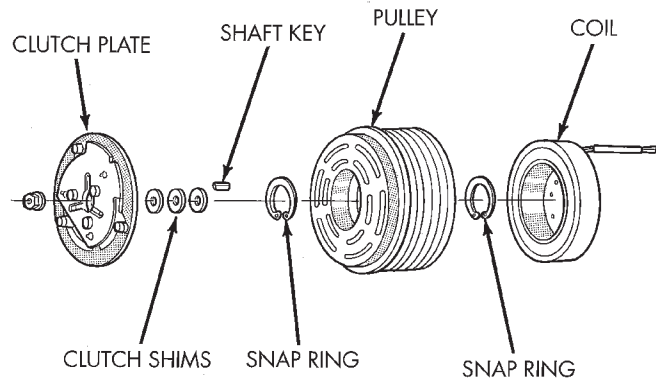

J9524-33

Fig. 2 Compressor Clutch - Typical

pressure cycling clutch switch, the high pressure cut-off switch, the compressor clutch relay, and the Powertrain Control Module (PCM). The PCM may delay compressor clutch engagement for up to thirty seconds. Refer to Group 14 - Fuel System for more information on the PCM controls.

COMPRESSOR CLUTCH RELAY

The compressor clutch relay is a International Standards Organization (ISO) micro-relay. The terminal designations and functions are the same as a conventional ISO relay. However, the micro-relay terminal orientation (footprint) is different, the current capacity is lower, and the relay case dimensions are smaller than those of the conventional ISO relay.

The compressor clutch relay is an electromechanical device that switches battery current to the compressor clutch coil when the Powertrain Control Module (PCM) grounds the coil side of the relay. The PCM responds to inputs from the A/C compressor switch on the heater-A/C control panel, the Automatic Zone Control (AZC) control module (if the vehicle is so equipped), the low pressure cycling clutch switch, and the high pressure cut-off switch. See Compressor Clutch Relay in the Diagnosis and Testing section of this group for more information.

The compressor clutch relay is located in the Power Distribution Center (PDC) in the engine compartment. Refer to the PDC label for relay identification and location.

The compressor clutch relay cannot be repaired and, if faulty or damaged, it must be replaced.

CONDENSER

The condenser is located in the air flow in front of the engine cooling radiator. The condenser is a heat exchanger that allows the high-pressure refrigerant gas being discharged by the compressor to give up its heat to the air passing over the condenser fins. When the refrigerant gas gives up its heat, it condenses.

DESCRIPTION AND OPERATION (Continued)

When the refrigerant leaves the condenser, it has become a high-pressure liquid refrigerant.

The volume of air flowing over the condenser fins is critical to the proper cooling performance of the air conditioning system. Therefore, it is important that there are no objects placed in front of the radiator grille openings in the front of the vehicle or foreign material on the condenser fins that might obstruct proper air flow. Also, any factory-installed air seals or shrouds must be properly reinstalled following radiator or condenser service.

The condenser cannot be repaired and, if faulty or damaged, it must be replaced.

EVAPORATOR COIL

The evaporator coil is located in the heater-A/C housing, under the instrument panel. The evaporator coil is positioned in the heater-A/C housing so that all air that enters the housing must pass over the fins of the evaporator before it is distributed through the system ducts and outlets. However, air passing over the evaporator coil fins will only be conditioned when the compressor is engaged and circulating refrigerant through the evaporator coil tubes.

Refrigerant enters the evaporator from the variable orifice tube as a low-temperature, low-pressure liquid. As air flows over the fins of the evaporator, the humidity in the air condenses on the fins, and the heat from the air is absorbed by the refrigerant. Heat absorption causes the refrigerant to boil and vaporize. The refrigerant becomes a low-pressure gas before it leaves the evaporator.

The evaporator coil cannot be repaired and, if faulty or damaged, it must be replaced.

HEATER CORE

The heater core is located in the heater-A/C housing, under the instrument panel. It is a heat exchanger made of rows of tubes and fins. Engine coolant is circulated through heater hoses to the heater core at all times. As the coolant flows through the heater core, heat removed from the engine is transferred to the heater core fins and tubes.

Air directed through the heater core picks up the heat from the heater core fins. The blend air door allows control of the heater output air temperature by controlling how much of the air flowing through the heater-A/C housing is directed through the heater core. The blower motor speed controls the volume of air flowing through the heater-A/C housing.

The heater core cannot be repaired and, if faulty or damaged, it must be replaced. Refer to Group 7 - Cooling System for more information on the engine cooling system, the engine coolant and the heater hoses.

HEATER AND AIR CONDITIONER

A manual temperature control type heating-air conditioning system is standard factory-installed equipment on this model. An electronically controlled Automatic Zone Control (AZC) type heating-air conditioning system is an available factory-installed option.

All vehicles are equipped with a common heater-A/C housing assembly (Fig. 3). The system combines air conditioning, heating, and ventilating capabilities in a single unit housing mounted under the instrument panel.

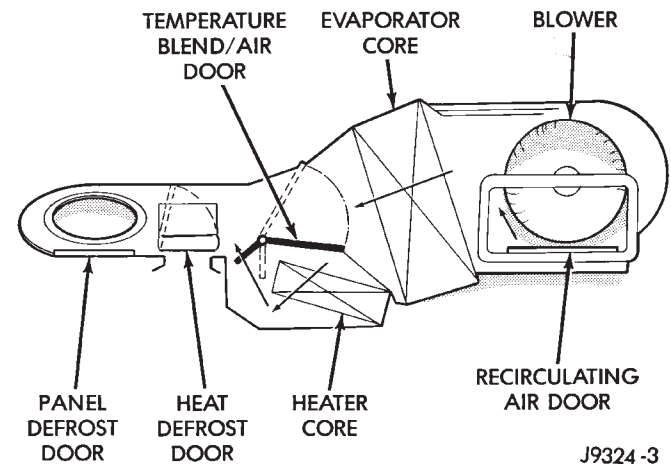

Fig. 3 Common Blend-Air Heater-Air Conditioner System

Outside fresh air enters the vehicle through the cowl top opening at the base of the windshield, and passes through a plenum chamber to the heater-A/C system blower housing. Air flow velocity can then be adjusted with the blower motor speed selector switch on the heater-A/C control panel. The air intake openings must be kept free of snow, ice, leaves, and other obstructions for the heater-A/C system to receive a sufficient volume of outside air.

It is also important to keep the air intake openings clear of debris because leaf particles and other debris that is small enough to pass through the cowl plenum screen can accumulate within the heater-A/C housing. The closed, warm, damp and dark environment created within the heater-A/C housing is ideal for the growth of certain molds, mildews and other fungi. Any accumulation of decaying plant matter provides an additional food source for fungal spores, which enter the housing with the fresh air. Excess debris, as well as objectionable odors created by decaying plant matter and growing fungi can be discharged into the passenger compartment during heater-A/C system operation.

Both the manual and AZC heater and air conditioner are blend-air type systems. In a blend-air system, a blend-air door controls the amount of

DESCRIPTION AND OPERATION (Continued)

unconditioned air (or cooled air from the evaporator) that is allowed to flow through, or around, the heater core. A temperature control knob on the heater-A/C control panel determines the discharge air temperature by energizing the blend-air door motor, which operates the blend-air door. This allows an almost immediate control of the output air temperature of the system. The AZC system will have separate blend-air doors and temperature controls for each front seat occupant.

The mode control knob on the heater-A/C control panel is used to direct the conditioned air to the selected system outlets. On manual temperature control systems, the mode control knob switches engine vacuum to control the mode doors, which are operated by vacuum actuator motors. On AZC systems, the mode control knob switches electrical current to control the mode doors, which are operated by electronic actuator motors.

The outside air intake can be shut off on manual temperature control systems by selecting the Recirculation Mode with the mode control knob. The outside air intake can be shut off on Automatic Zone Control (AZC) type system by pushing the Recirculation Mode button. This will operate the recirculating air door that closes off the outside fresh air intake and recirculates the air that is already inside the vehicle.

The air conditioner for all models is designed for the use of non-CFC, R-134a refrigerant. The air conditioning system has an evaporator to cool and dehumidify the incoming air prior to blending it with the heated air. This air conditioning system uses a variable orifice tube in the liquid line near the condenser outlet tube to meter refrigerant flow to the evaporator coil. To maintain minimum evaporator temperature and prevent evaporator freezing, a fixed pressure setting switch on the accumulator cycles the compressor clutch.

HEATER AND AIR CONDITIONER CONTROL

The manual temperature control heater-A/C system uses a combination of electrical, and vacuum controls. The Automatic Zone Control (AZC) heater-A/C system uses only electrical controls. These controls provide the vehicle operator with a number of setting options to help control the climate and comfort within the vehicle. Refer to the owner's manual in the vehicle glove box for more information on the suggested operation and use of these controls.

Both heater-A/C control panels are located on the instrument panel inboard of the steering column and below the radio (Fig. 4). Both control panels contain rotary-type temperature control knob(s), a rotary-type mode control switch knob, a rotary-type blower motor speed switch knob and an air conditioning compressor push button switch. The Rear Window

Defogger push button switch is also located on heater-A/C control panel. The AZC control panel also features a Recirc push button switch and a vacuum fluorescent display area.

MANUAL AIR CONDITIONING SYSTEM

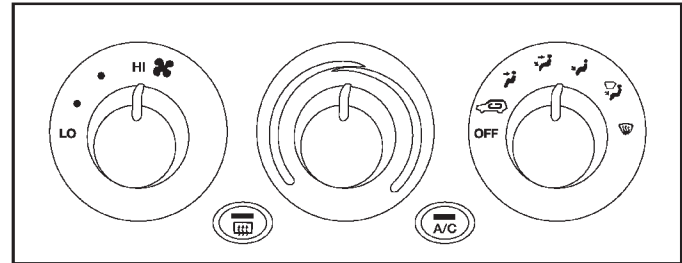

AUTOMATIC ZONE CONTROL SYSTEM

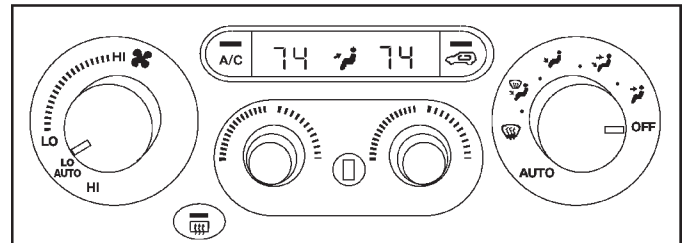

80b6f021

Fig. 4 Heater-Air Conditioner Control Panels

The AZC control module uses infrared sensing technology to control occupant comfort levels, not the actual passenger compartment air temperature. Dual infrared sensors mounted in the face of the control unit independently measure the surface temperature to maintain customer-perceived comfort temperature under changing conditions. Dual Zone temperature control provides wide side-to-side variation in comfort temperature to exceed the needs of either front seat occupant. This sensing system replaces interior air temperature and solar sensors used to approximate direct sensing control through complex control programs.

Both the manual heater-A/C control panel and the AZC control panel are serviced only as complete units and cannot be repaired. If faulty or damaged, the entire control panel unit must be replaced.

HIGH PRESSURE RELIEF VALVE

A high pressure relief valve is located on the compressor manifold, which is on the side of the compressor. This mechanical valve is designed to vent refrigerant from the system to protect against damage to the compressor and other system components, caused by condenser air flow restriction or an overcharge of refrigerant.

The high pressure relief valve vents the system when a discharge pressure of 3445 to 4135 kPa (500 to 600 psi) or above is reached. The valve closes

DESCRIPTION AND OPERATION (Continued)

when a minimum discharge pressure of 2756 kPa (400 psi) is reached.

The high pressure relief valve vents only enough refrigerant to reduce the system pressure, and then re-seats itself. The majority of the refrigerant is conserved in the system. If the valve vents refrigerant, it does not mean that the valve is faulty.

The high pressure relief valve is a factory-calibrated unit. The valve cannot be adjusted or repaired, and must not be removed or otherwise disturbed. The valve is only serviced as a part of the compressor assembly.

HIGH PRESSURE SWITCH

The high pressure switch is located on the discharge line or discharge line block fitting near the compressor. The switch is screwed onto a fitting that contains a Schrader-type valve, which allows the switch to be serviced without discharging the refrigerant system. The discharge line fitting is equipped with an O-ring to seal the switch connection.

The high pressure switch is connected in series electrically with the low pressure switch between ground and the Powertrain Control Module (PCM). The switch contacts open and close causing the PCM to turn the compressor clutch on and off. This prevents compressor operation when the discharge line pressure approaches high levels.

The high pressure switch contacts are open when the discharge line pressure rises above 3100 to 3375 kPa (450 to 490 psi). The switch contacts will close when the discharge line pressure drops to 1860 to 2275 kPa (270 to 330 psi).

The high pressure switch is a factory-calibrated unit. The switch cannot be adjusted or repaired and, if faulty or damaged, it must be replaced.

INFRARED TEMPERATURE SENSOR

Models equipped with the optional Automatic Zone Control (AZC) system use automatic dual zone temperature control with infrared sensing technology. The temperature sensor is located in the center instrument panel, between the dual temperature knobs of the AZC.

The AZC module uses infrared sensing technology to control occupant comfort levels, not the actual passenger compartment air temperature. Dual infrared sensors mounted in the face of the control unit independently measure the surface temperature to maintain customer-perceived comfort temperature under changing conditions. Dual Zone temperature control provides wide side-to-side variation in comfort temperature to exceed the needs of either front seat occupant. This sensing system replaces interior air temperature and solar sensors used to approximate

direct sensing control through complex control programs.

The infrared temperature sensor cannot be adjusted or repaired and, if faulty or damaged, the module must be replaced.

NOTE: The infrared sensor window may be permanently damaged if any type of cosmetic vinyl dressings are allowed to contact the lens. Avoid spraying or wiping this area with any cleaner or conditioner. This may result in impaired temperature sensing and control.

LOW PRESSURE SWITCH

The low pressure switch is located on the top of the accumulator. The switch is screwed onto an accumulator fitting that contains a Schrader-type valve, which allows the switch to be serviced without discharging the refrigerant system. The accumulator fitting is equipped with an O-ring to seal the switch connection.

The low pressure switch is connected in series electrically with the high pressure switch, between ground and the Powertrain Control Module (PCM). The switch contacts open and close causing the PCM to turn the compressor clutch on and off. This regulates the refrigerant system pressure and controls evaporator temperature. Controlling the evaporator temperature prevents condensate water on the evaporator fins from freezing and obstructing air conditioning system air flow.

The low pressure switch contacts are open when the suction pressure is approximately 141 kPa (20.5 psi) or lower. The switch contacts will close when the suction pressure rises to approximately 234 to 262 kPa (34 to 38 psi) or above. Lower ambient temperatures, below approximately -1° C (30° F), will also cause the switch contacts to open. This is due to the pressure/temperature relationship of the refrigerant in the system.

The low pressure switch is a factory-calibrated unit. It cannot be adjusted or repaired and, if faulty or damaged, it must be replaced.

REFRIGERANT

The refrigerant used in this air conditioning system is a HydroFluoroCarbon (HFC), type R-134a. Unlike R-12, which is a ChloroFluoroCarbon (CFC), R-134a refrigerant does not contain ozone-depleting chlorine. R-134a refrigerant is a non-toxic, non-flammable, clear, and colorless liquefied gas.

Even though R-134a does not contain chlorine, it must be reclaimed and recycled just like CFC-type refrigerants. This is because R-134a is a greenhouse gas and can contribute to global warming.

DESCRIPTION AND OPERATION (Continued)

R-134a refrigerant is not compatible with R-12 refrigerant in an air conditioning system. Even a small amount of R-12 added to an R-134a refrigerant system will cause compressor failure, refrigerant oil sludge or poor air conditioning system performance. In addition, the PolyAlkylene Glycol (PAG) synthetic refrigerant oils used in an R-134a refrigerant system are not compatible with the mineral-based refrigerant oils used in an R-12 refrigerant system.

R-134a refrigerant system service ports, service tool couplers and refrigerant dispensing bottles have all been designed with unique fittings to ensure that an R-134a system is not accidentally contaminated with the wrong refrigerant (R-12). There are also labels posted in the engine compartment of the vehicle and on the compressor identifying to service technicians that the air conditioning system is equipped with R-134a.

REFRIGERANT LINES

The refrigerant lines and hoses are used to carry the refrigerant between the various air conditioning system components. A barrier hose design with a nylon tube inner hose liner is used for the R-134a air conditioning system on this vehicle. This nylon liner helps to further contain the R-134a refrigerant, which has a smaller molecular structure than R-12 refrigerant. The ends of the refrigerant hoses are made from lightweight aluminum or steel, and use braze-less fittings.

Any kinks or sharp bends in the refrigerant plumbing will reduce the capacity of the entire air conditioning system. Kinks and sharp bends reduce the flow of refrigerant in the system. A good rule for the flexible hose refrigerant lines is to keep the radius of all bends at least ten times the diameter of the hose. In addition, the flexible hose refrigerant lines should be routed so they are at least 80 millimeters (3 inches) from the exhaust manifold.

High pressures are produced in the refrigerant system when the air conditioning compressor is operating. Extreme care must be exercised to make sure that each of the refrigerant system connections is pressure-tight and leak free. It is a good practice to inspect all flexible hose refrigerant lines at least once a year to make sure they are in good condition and properly routed.

The refrigerant lines and hoses are coupled with other components of the HVAC system with peanut-block style fittings. A stat-O seal type flat steel gasket with a captured compressible O-ring, is used to mate plumbing lines with A/C components to ensure the integrity of the refrigerant system.

The refrigerant lines and hoses cannot be repaired and, if faulty or damaged, they must be replaced.

REFRIGERANT OIL

The refrigerant oil used in R-134a refrigerant systems is a synthetic-based, PolyAlkylene Glycol (PAG), wax-free lubricant. Mineral-based R-12 refrigerant oils are not compatible with PAG oils, and should never be introduced to an R-134a refrigerant system.

There are different PAG oils available, and each contains a different additive package. The 10PA17 compressor used in this vehicle is designed to use an ND8 PAG refrigerant oil. Use only refrigerant oil of this same type to service the refrigerant system.

After performing any refrigerant recovery or recycling operation, always replenish the refrigerant system with the same amount of the recommended refrigerant oil as was removed. Too little refrigerant oil can cause compressor damage, and too much can reduce air conditioning system performance.

PAG refrigerant oil is much more hygroscopic than mineral oil, and will absorb any moisture it comes into contact with, even moisture in the air. The PAG oil container should always be kept tightly capped until it is ready to be used. After use, recap the oil container immediately to prevent moisture contamination.

REFRIGERANT SYSTEM SERVICE EQUIPMENT

WARNING: EYE PROTECTION MUST BE WORN WHEN SERVICING AN AIR CONDITIONING REFRIGERANT SYSTEM. TURN OFF (ROTATE CLOCKWISE) ALL VALVES ON THE EQUIPMENT BEING USED BEFORE CONNECTING TO, OR DISCONNECTING FROM THE REFRIGERANT SYSTEM. FAILURE TO OBSERVE THESE WARNINGS MAY RESULT IN PERSONAL INJURY.

When servicing the air conditioning system, a R-134a refrigerant recovery/recycling/charging station that meets SAE Standard J2210 must be used. Contact an automotive service equipment supplier for refrigerant recovery/recycling/charging equipment. Refer to the operating instructions supplied by the equipment manufacturer for proper care and use of this equipment.

A manifold gauge set may be needed with some recovery/recycling/charging equipment (Fig. 5). The service hoses on the gauge set being used should have manual (turn wheel), or automatic back-flow valves at the service port connector ends. This will prevent refrigerant from being released into the atmosphere.

MANIFOLD GAUGE SET CONNECTIONS

CAUTION: Do not use an R-12 manifold gauge set on an R-134a system. The refrigerants are not compatible and system damage will result.

DESCRIPTION AND OPERATION (Continued)

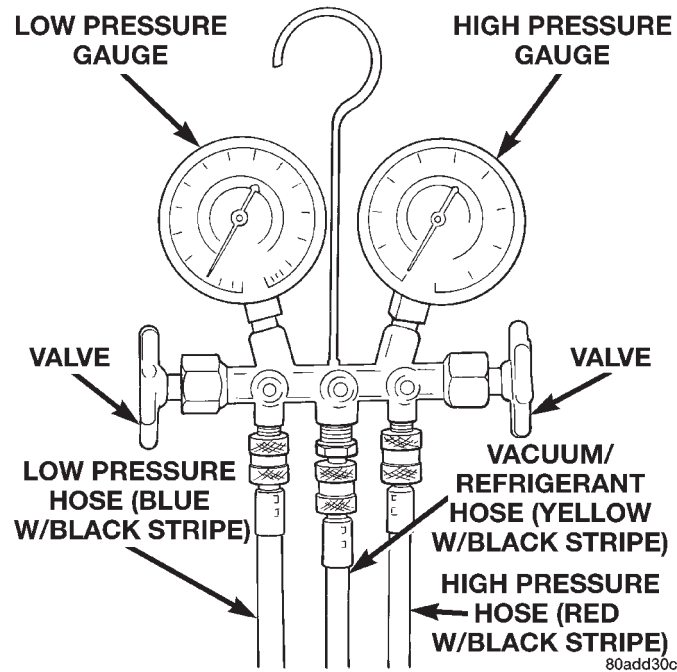

Fig. 5 Manifold Gauge Set - Typical

LOW PRESSURE GAUGE HOSE The low pressure hose (Blue with Black stripe) attaches to the suction service port. This port is located on the liquid line, near the evaporator at the rear of the engine compartment.

HIGH PRESSURE GAUGE HOSE The high pressure hose (Red with Black stripe) attaches to the discharge service port. This port is located on the compressor manifold on the side of the compressor.

RECOVERY/RECYCLING/EVACUATION/CHARGING HOSE The center manifold hose (Yellow, or White, with Black stripe) is used to recover, evacuate, and charge the refrigerant system. When the low or high pressure valves on the manifold gauge set are opened, the refrigerant in the system will escape through this hose.

REFRIGERANT SYSTEM SERVICE PORT

The two refrigerant system service ports are used to charge, recover/recycle, evacuate, and test the air conditioning refrigerant system. Unique service port coupler sizes are used on the R-134a system, to ensure that the refrigerant system is not accidentally contaminated by the use of the wrong refrigerant (R-12), or refrigerant system service equipment.

The high pressure service port is located on the discharge line off the side of the compressor. The low pressure service port is located on the suction line near the evaporator at the rear of the engine compartment.

Each of the service ports has a threaded plastic protective cap installed over it from the factory. After

servicing the refrigerant system, always reinstall both of the service port caps.

SERVICE WARNINGS AND PRECAUTIONS

WARNING:

- **THE AIR CONDITIONING SYSTEM CONTAINS REFRIGERANT UNDER HIGH PRESSURE. SEVERE PERSONAL INJURY MAY RESULT FROM IMPROPER SERVICE PROCEDURES. REPAIRS SHOULD ONLY BE PERFORMED BY QUALIFIED SERVICE PERSONNEL.**

- **AVOID BREATHING THE REFRIGERANT AND REFRIGERANT OIL VAPOR OR MIST. EXPOSURE MAY IRRITATE THE EYES, NOSE, AND/OR THROAT. WEAR EYE PROTECTION WHEN SERVICING THE AIR CONDITIONING REFRIGERANT SYSTEM. SERIOUS EYE INJURY CAN RESULT FROM DIRECT CONTACT WITH THE REFRIGERANT. IF EYE CONTACT OCCURS, SEEK MEDICAL ATTENTION IMMEDIATELY.**

- **DO NOT EXPOSE THE REFRIGERANT TO OPEN FLAME. POISONOUS GAS IS CREATED WHEN REFRIGERANT IS BURNED. AN ELECTRONIC LEAK DETECTOR IS RECOMMENDED.**

- **IF ACCIDENTAL SYSTEM DISCHARGE OCCURS, VENTILATE THE WORK AREA BEFORE RESUMING SERVICE. LARGE AMOUNTS OF REFRIGERANT RELEASED IN A CLOSED WORK AREA WILL DISPLACE THE OXYGEN AND CAUSE SUFFOCATION.**

- **THE EVAPORATION RATE OF R-134a REFRIGERANT AT AVERAGE TEMPERATURE AND ALTITUDE IS EXTREMELY HIGH. AS A RESULT, ANYTHING THAT COMES IN CONTACT WITH THE REFRIGERANT WILL FREEZE. ALWAYS PROTECT THE SKIN OR DELICATE OBJECTS FROM DIRECT CONTACT WITH THE REFRIGERANT.**

- **THE R-134a SERVICE EQUIPMENT OR THE VEHICLE REFRIGERANT SYSTEM SHOULD NOT BE PRESSURE TESTED OR LEAK TESTED WITH COMPRESSED AIR. SOME MIXTURES OF AIR AND R-134a HAVE BEEN SHOWN TO BE COMBUSTIBLE AT ELEVATED PRESSURES. THESE MIXTURES ARE POTENTIALLY DANGEROUS, AND MAY RESULT IN FIRE OR EXPLOSION CAUSING INJURY OR PROPERTY DAMAGE.**

DESCRIPTION AND OPERATION (Continued)

CAUTION:

- Liquid refrigerant is corrosive to metal surfaces. Follow the operating instructions supplied with the service equipment being used.
- Never add R-12 to a refrigerant system designed to use R-134a. Damage to the system will result.
- R-12 refrigerant oil must not be mixed with R-134a refrigerant oil. They are not compatible.
- Do not use R-12 equipment or parts on the R-134a system. Damage to the system will result.
- Do not overcharge the refrigerant system. This will cause excessive compressor head pressure and can cause noise and system failure.
- Recover the refrigerant before opening any fitting or connection. Open the fittings with caution, even after the system has been discharged. Never open or loosen a connection before recovering the refrigerant.
- Do not remove the secondary retention clip from any spring-lock coupler connection while the refrigerant system is under pressure. Recover the refrigerant before removing the secondary retention clip. Open the fittings with caution, even after the system has been discharged. Never open or loosen a connection before recovering the refrigerant.
- The refrigerant system must always be evacuated before charging.
- Do not open the refrigerant system or uncap a replacement component until you are ready to service the system. This will prevent contamination in the system.
- Before disconnecting a component, clean the outside of the fittings thoroughly to prevent contamination from entering the refrigerant system.
- Immediately after disconnecting a component from the refrigerant system, seal the open fittings with a cap or plug.
- Before connecting an open refrigerant fitting, always install a new seal or gasket. Coat the fitting and seal with clean refrigerant oil before connecting.
- Do not remove the sealing caps from a replacement component until it is to be installed.
- When installing a refrigerant line, avoid sharp bends that may restrict refrigerant flow. Position the refrigerant lines away from exhaust system components or any sharp edges, which may damage the line.
- Tighten refrigerant fittings only to the specified torque. The aluminum fittings used in the refrigerant system will not tolerate overtightening.
- When disconnecting a refrigerant fitting, use a wrench on both halves of the fitting. This will prevent twisting of the refrigerant lines or tubes.

- Refrigerant oil will absorb moisture from the atmosphere if left uncapped. Do not open a container of refrigerant oil until you are ready to use it. Replace the cap on the oil container immediately after using. Store refrigerant oil only in a clean, airtight, and moisture-free container.

- Keep service tools and the work area clean. Contamination of the refrigerant system through careless work habits must be avoided.

COOLING SYSTEM REQUIREMENTS

To maintain the performance level of the heating-air conditioning system, the engine cooling system must be properly maintained. The use of a bug screen is not recommended. Any obstructions in front of the radiator or condenser will reduce the performance of the air conditioning and engine cooling systems.

The engine cooling system includes the heater core and the heater hoses. Refer to Group 7 - Cooling System for more information before the opening of, or attempting any service to the engine cooling system.

REFRIGERANT HOSES/LINES/TUBES PRECAUTIONS

Kinks or sharp bends in the refrigerant plumbing will reduce the capacity of the entire system. High pressures are produced in the system when it is operating. Extreme care must be exercised to make sure that all refrigerant system connections are pressure tight.

A good rule for the flexible hose refrigerant lines is to keep the radius of all bends at least ten times the diameter of the hose. Sharp bends will reduce the flow of refrigerant. The flexible hose lines should be routed so they are at least 80 millimeters (3 inches) from the exhaust manifold. It is a good practice to inspect all flexible refrigerant system hose lines at least once a year to make sure they are in good condition and properly routed.

There are two types of refrigerant fittings:

- All fittings with O-rings need to be coated with refrigerant oil before installation. Use only O-rings that are the correct size and approved for use with R-134a refrigerant. Failure to do so may result in a leak.

- Refrigerant line connections with Stat-O seal type gaskets cannot be serviced with O-rings. The gaskets are not reusable and should be replaced any time the connection has been opened for service.

Using the proper tools when making a refrigerant plumbing connection is very important. Improper tools or improper use of the tools can damage the refrigerant fittings. Always use two wrenches when loosening or tightening tube fittings. Use one wrench

DESCRIPTION AND OPERATION (Continued)

to hold one side of the connection stationary, while loosening or tightening the other side of the connection with a second wrench.

The refrigerant must be recovered completely from the system before opening any fitting or connection. Open the fittings with caution, even after the refrigerant has been recovered. If any pressure is noticed as a fitting is loosened, tighten the fitting and recover the refrigerant from the system again.

Do not discharge refrigerant into the atmosphere. Use an R-134a refrigerant recovery/recycling device that meets SAE Standard J2210.

The refrigerant system will remain chemically stable as long as pure, moisture-free R-134a refrigerant and refrigerant oil is used. Dirt, moisture, or air can upset this chemical stability. Operational troubles or serious damage can occur if foreign material is present in the refrigerant system.

When it is necessary to open the refrigerant system, have everything needed to service the system ready. The refrigerant system should not be left open to the atmosphere any longer than necessary. Cap or plug all lines and fittings as soon as they are opened to prevent the entrance of dirt and moisture. All lines and components in parts stock should be capped or sealed until they are to be installed.

All tools, including the refrigerant recycling equipment, the manifold gauge set, and test hoses should be kept clean and dry. All tools and equipment must be designed for R-134a refrigerant.

VACUUM CHECK VALVE

A vacuum check valve (non AZC only) is installed in the accessory vacuum supply line in the engine compartment, near the vacuum tap on the engine intake manifold. The vacuum check valve is designed to allow vacuum to flow in only one direction through the accessory vacuum supply circuits.

The use of a vacuum check valve helps to maintain the system vacuum needed to retain the selected heater-A/C mode settings. The check valve will prevent the engine from bleeding down system vacuum through the intake manifold during extended heavy engine load (low engine vacuum) operation.

The vacuum check valve cannot be repaired and, if faulty or damaged, it must be replaced.

VACUUM RESERVOIR

The vacuum reservoir is mounted in the right front of the vehicle behind the headlamp mounting module (Fig. 6). The headlamp mounting module and headlamp assembly must be removed from the vehicle to access the vacuum reservoir for service. Refer to Group 8L - Lamps for more information on component removal.

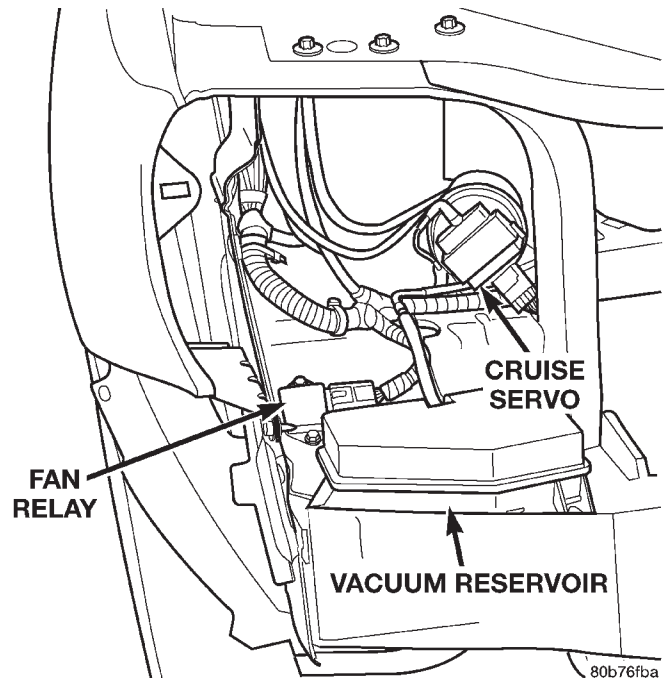

Fig. 6 Vacuum Reservoir

Engine vacuum is stored in the vacuum reservoir. The stored vacuum is used to operate the vacuum-controlled vehicle accessories during periods of low engine vacuum such as when the vehicle is climbing a steep grade, or under other high engine load operating conditions.

The vacuum reservoir cannot be repaired and, if faulty or damaged, it must be replaced.

VACUUM SYSTEM

Vacuum control is used to operate the mode doors in the standard equipment manual temperature control system heater-A/C housing. Testing of the heater-A/C mode control switch operation will determine if the vacuum, and electrical controls are functioning. However, it is possible that a vacuum control system that operates perfectly at engine idle (high engine vacuum) may not function properly at high engine speeds or loads (low engine vacuum). This can be caused by leaks in the vacuum system, or a faulty vacuum check valve.

A vacuum system test will help to identify the source of poor vacuum system performance or vacuum system leaks. Before starting this test, stop the engine and make certain that the problem isn't a disconnected vacuum supply tube at the engine intake manifold vacuum tap or the vacuum reservoir.

Use an adjustable vacuum test set (Special Tool C-3707-B) and a suitable vacuum pump to test the heater-A/C vacuum control system. With a finger placed over the end of the vacuum test hose probe (Fig. 7), adjust the bleed valve on the test set gauge to obtain a vacuum of exactly 27 kPa (8 in. Hg.).

DESCRIPTION AND OPERATION (Continued)

Release and block the end of the probe several times to verify that the vacuum reading returns to the exact 27 kPa (8 in. Hg.) setting. Otherwise, a false reading will be obtained during testing.

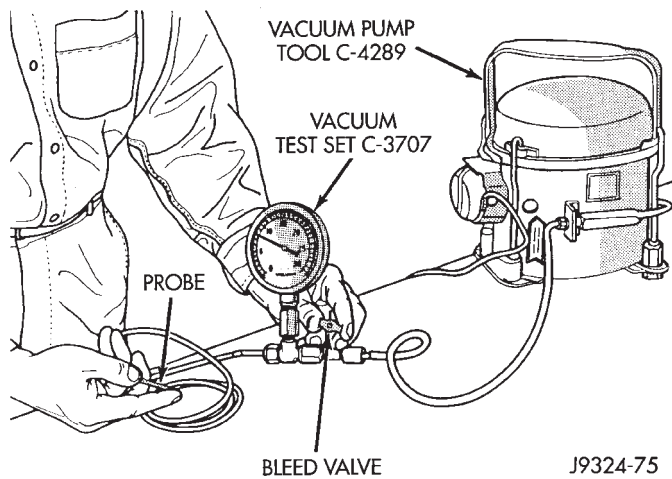

Fig. 7 Adjust Vacuum Test Bleed Valve-Typical

VACUUM CHECK VALVE

(1) Remove the vacuum check valve. The valve is located in the (black) vacuum supply tube at the engine intake manifold vacuum tap.

(2) Connect the test set vacuum supply hose to the heater-A/C control side of the valve. When connected to this side of the check valve, no vacuum should pass and the test set gauge should return to the 27 kPa (8 in. Hg.) setting. If OK, go to step Step 3. If not OK, replace the faulty valve.

(3) Connect the test set vacuum supply hose to the engine vacuum side of the valve. When connected to this side of the check valve, vacuum should flow through the valve without restriction. If not OK, replace the faulty valve.

HEATER-A/C CONTROLS

(1) Connect the test set vacuum probe to the heater-A/C vacuum supply (black) tube in the engine compartment. Position the test set gauge so that it can be viewed from the passenger compartment.

(2) Place the heater-A/C mode control switch knob in each mode position, one position at a time, and pause after each selection. The test set gauge should return to the 27 kPa (8 in. Hg.) setting shortly after each selection is made. If not OK, a component or vacuum line in the vacuum circuit of the selected mode has a leak. See the procedure in Locating Vacuum Leaks.

CAUTION: Do not use lubricant on the switch ports or in the holes in the plug, as lubricant will ruin the vacuum valve in the switch. A drop of clean water in the connector plug holes will help the connector slide onto the switch ports.

LOCATING VACUUM LEAKS

WARNING: ON VEHICLES EQUIPPED WITH AIR-BAGS, REFER TO GROUP 8M - PASSIVE RESTRAINT SYSTEMS BEFORE ATTEMPTING ANY STEERING WHEEL, STEERING COLUMN, OR INSTRUMENT PANEL COMPONENT DIAGNOSIS OR SERVICE. FAILURE TO TAKE THE PROPER PRECAUTIONS COULD RESULT IN ACCIDENTAL AIR-BAG DEPLOYMENT AND POSSIBLE PERSONAL INJURY.

(1) Disconnect the vacuum harness connector from the back of the heater-A/C mode control switch on the control panel.

(2) Connect the test set vacuum hose probe to each port in the vacuum harness connector, one at a time, and pause after each connection (Fig. 8). The test set gauge should return to the 27 kPa (8 in. Hg.) setting shortly after each connection is made. If OK, replace the faulty mode control switch. If not OK, go to Step 3.

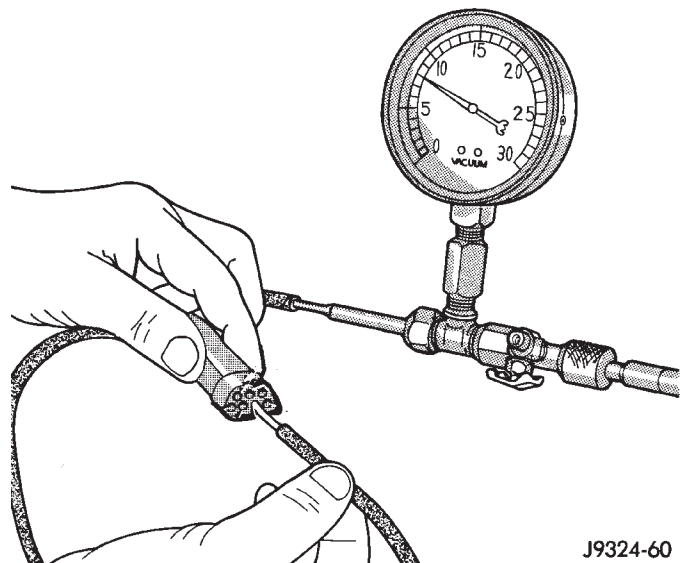

Fig. 8 Vacuum Circuit Test

(3) Determine the vacuum line color of the vacuum circuit that is leaking. To determine the vacuum line colors, refer to the Vacuum Circuits chart (Fig. 9).

(4) Disconnect and plug the vacuum line from the component (fitting, actuator, valve, switch, or reservoir) on the other end of the leaking circuit. Instrument panel disassembly or removal may be necessary to gain access to some components.

(5) Connect the test set hose or probe to the open end of the leaking circuit. The test set gauge should return to the 27 kPa (8 in. Hg.) setting shortly after each connection is made. If OK, replace the faulty disconnected component. If not OK, go to Step 6.

DESCRIPTION AND OPERATION (Continued)

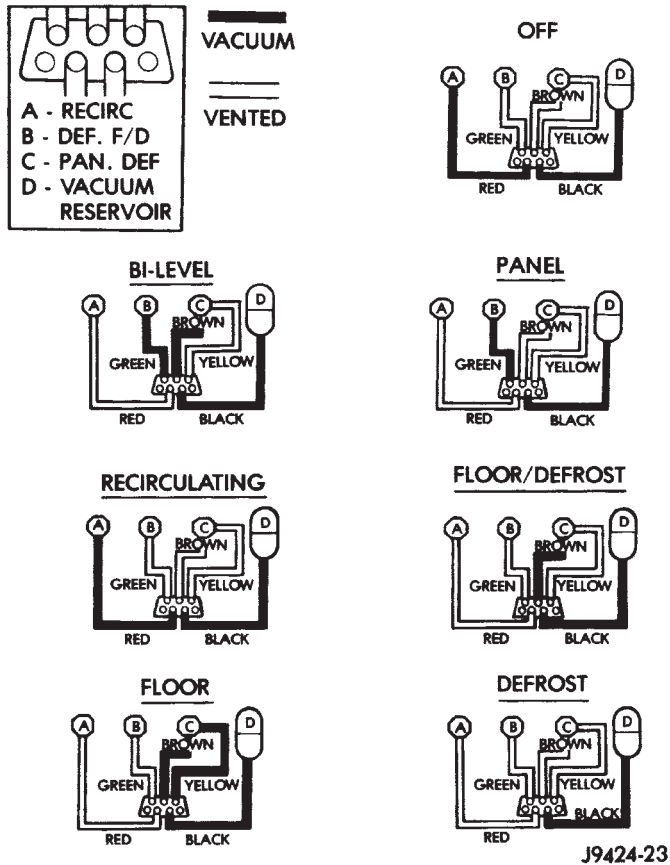

Fig. 9 Vacuum Circuits

(6) To locate a leak in a vacuum line, leave one end of the line plugged and connect the test set hose or probe to the other end. Run your fingers slowly along the line while watching the test set gauge. The vacuum reading will fluctuate when your fingers contact the source of the leak. To repair the vacuum line, cut out the leaking section of the line. Then, insert the loose ends of the line into a suitable length of 3 millimeter (1/8-inch) inside diameter rubber hose.

VARIABLE ORIFICE VALVE

The Variable Orifice Valve (VOV) is installed in the liquid line between the outlet of the condenser and the inlet of the evaporator. The VOV is only serviced as an integral part of the liquid line.

The VOV contains two orifices which work in parallel. The fixed orifice works along with the variable port, to regulate refrigerant expansion in the evaporator in a manner that is suitable for most operating conditions.

The inlet end of the Variable Orifice Valve has a nylon mesh filter screen, which filters the refrigerant and helps to reduce the potential for blockage of the metering orifices by refrigerant system contaminants (Fig. 10). The outlet end of the tube has a nylon

mesh diffuser screen. The O-rings on the plastic body of the VOV seal the tube to the inside of the liquid line and prevent the refrigerant from bypassing the fixed metering orifices. A thermostatic bimetal coil wrapped around the valve body serves as a refrigerant regulator during temperature changes.

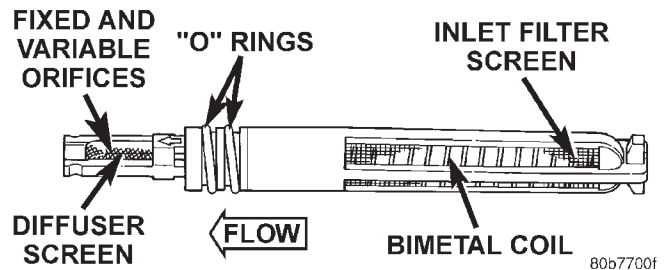

Fig. 10 Variable Orifice Valve

The VOV is used to meter the flow of liquid refrigerant into the evaporator coil. The high-pressure liquid refrigerant from the condenser expands into a low-pressure liquid/vapor as it passes through the metering orifices and diffuser screen of the valve.

The VOV varies the flow of refrigerant in response to the refrigerant temperature exiting the condenser. As condenser discharge refrigerant temperature increases, the variable port is progressively closed. A higher temperature (while idling) equals more restriction. A lower temperature (at road speed) will have less restriction.

The Variable Orifice Valve cannot be repaired and, if faulty or plugged, the liquid line assembly must be replaced.

DIAGNOSIS AND TESTING

A/C PERFORMANCE

The air conditioning system is designed to provide the passenger compartment with low temperature and low humidity air. The evaporator, located in the heater-A/C housing on the dash panel below the instrument panel, is cooled to temperatures near the freezing point. As warm damp air passes through the cooled evaporator, the air transfers its heat to the refrigerant in the evaporator and the moisture in the air condenses on the evaporator fins. During periods of high heat and humidity, an air conditioning system will be more effective in the Recirculation Mode. With the system in the Recirculation Mode, only air from the passenger compartment passes through the evaporator. As the passenger compartment air dehumidifies, the air conditioning system performance levels improve.

Humidity has an important bearing on the temperature of the air delivered to the interior of the vehicle. It is important to understand the effect that

DIAGNOSIS AND TESTING (Continued)

humidity has on the performance of the air conditioning system. When humidity is high, the evaporator has to perform a double duty. It must lower the air temperature, and it must lower the temperature of the moisture in the air that condenses on the evaporator fins. Condensing the moisture in the air transfers heat energy into the evaporator fins and tubing. This reduces the amount of heat the evaporator can absorb from the air. High humidity greatly reduces the ability of the evaporator to lower the temperature of the air.

However, evaporator capacity used to reduce the amount of moisture in the air is not wasted. Wringing some of the moisture out of the air entering the vehicle adds to the comfort of the passengers. Although, an owner may expect too much from their air conditioning system on humid days. A performance test is the best way to determine whether the system is performing up to standard. This test also provides valuable clues as to the possible cause of trouble with the air conditioning system.

If the vehicle has the optional Automatic Zone Control (AZC) system, and has intermittent operational problems or fault codes, be certain that the 16-way wire harness connector on the heater-A/C housing is properly seated (Fig. 11). To check this condition, unplug the two wire harness connector halves, then plug them in again.

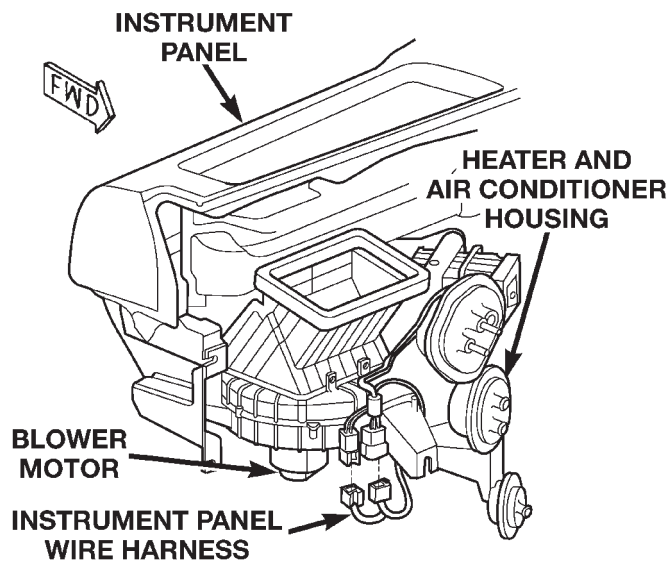

80b6b3b7

Fig. 11 16-Way Wire Harness Connector (AZC)

Review the Service Warnings and Precautions in the front of this group before performing this procedure. The air temperature in the test room and in the vehicle must be a minimum of 21° C (70° F) for this test.

(1) Connect a tachometer and a manifold gauge set.

(2) If the vehicle has the standard manual temperature control, set the heater-A/C mode control switch knob in the Panel position, the temperature control knob in the full cool (Recirculation Mode) position, the A/C button in the On position, and the blower motor switch knob in the highest speed position. If the vehicle has the optional AZC, set the heater-A/C mode control switch knob in the Panel position, the temperature control knob in the full cool position, the A/C and Recirc buttons in the On position, and the blower motor switch knob in the highest (manual) speed position.

(3) Start the engine and hold the idle at 1,000 rpm with the compressor clutch engaged.

(4) The engine should be at operating temperature. The doors and windows must be open.

(5) Insert a thermometer in the driver side center A/C (panel) outlet. Operate the engine for five minutes.

(6) The compressor clutch may cycle, depending upon the ambient temperature and humidity. If the clutch cycles, unplug the low pressure switch wire harness connector from the switch located on the accumulator (Fig. 12). Place a jumper wire across the terminals of the low pressure switch wire harness connector.

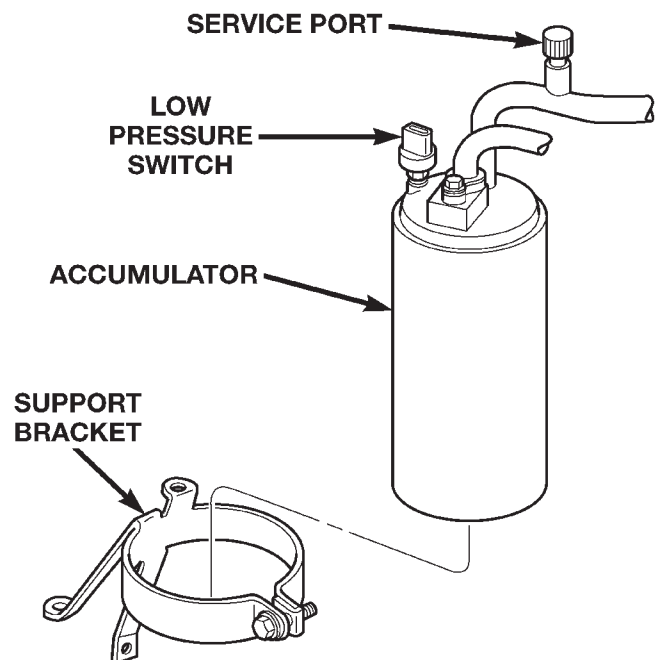

80b76f91

Fig. 12 Accumulator and Low Pressure Switch

(7) With the compressor clutch engaged, record the discharge air temperature and the compressor discharge pressure.

DIAGNOSIS AND TESTING (Continued)

(8) Compare the discharge air temperature to the Performance Temperature and Pressure chart. If the discharge air temperature is high, see Refrigerant System Leaks and Refrigerant System Charge in this group.

Performance Temperature and Pressure					
Ambient Air Temperature	21° C (70° F)	27° C (80° F)	32° C (90° F)	38° C (100° F)	43° C (110° F)
Air Temperature at Center Panel Outlet	-3 to 3° C (27 to 38° F)	1 to 7° C (33 to 44° F)	3 to 9° C (37 to 48° F)	6 to 13° C (43 to 55° F)	10 to 18° C (50 to 64° F)
Evaporator Inlet Pressure at Charge Port	179 to 241 kPa (26 to 35 psi)	221 to 283 kPa (32 to 41 psi)	262 to 324 kPa (38 to 47 psi)	303 to 365 kPa (44 to 53 psi)	345 to 414 kPa (50 to 60 psi)
Compressor Discharge Pressure	1240 to 1655 kPa (180 to 240 psi)	1380 to 1790 kPa (200 to 260 psi)	1720 to 2070 kPa (250 to 300 psi)	1860 to 2345 kPa (270 to 340 psi)	2070 to 2690 kPa (300 to 390 psi)

(9) Compare the compressor discharge pressure to the Performance Temperature and Pressure chart. If the compressor discharge pressure is high, see the Pressure Diagnosis chart.

Pressure Diagnosis		
Condition	Possible Causes	Correction
Rapid compressor clutch cycling (ten or more cycles per minute).	1. Low refrigerant system charge.	1. See Refrigerant System Leaks in this group. Test the refrigerant system for leaks. Repair, evacuate and charge the refrigerant system, if required.
Equal pressures, but the compressor clutch does not engage.	1. No refrigerant in the refrigerant system. 2. Faulty fuse. 3. Faulty compressor clutch coil. 4. Faulty compressor clutch relay. 5. Improperly installed or faulty low pressure switch. 6. Faulty high pressure switch. 7. Faulty Powertrain Control Module (PCM).	1. See Refrigerant System Leaks in this group. Test the refrigerant system for leaks. Repair, evacuate and charge the refrigerant system, if required. 2. Check the fuses in the Power Distribution Center and the fuseblock module. Repair the shorted circuit or component and replace the fuses, if required. 3. See Compressor Clutch Coil in this group. Test the compressor clutch coil and replace, if required. 4. See Compressor Clutch Relay in this group. Test the compressor clutch relay and relay circuits. Repair the circuits or replace the relay, if required. 5. See Low Pressure Cycling Clutch Switch in this group. Test the low pressure switch and tighten or replace, if required. 6. See High Pressure Switch in this group. Test the high pressure switch and replace, if required. 7. Refer to the proper Diagnostic Procedures manual for testing of the PCM. Test the PCM and replace, if required.

DIAGNOSIS AND TESTING (Continued)

Pressure Diagnosis		
Condition	Possible Causes	Correction
Normal pressures, but A/C Performance Test air temperatures at center panel outlet are too high.	<ol style="list-style-type: none"> 1. Excessive refrigerant oil in system. 2. Blend-air door motor, or wire harness improperly installed or faulty. 3. Blend-air door inoperative or sealing improperly. 	<ol style="list-style-type: none"> 1. See Refrigerant Oil Level in this group. Recover the refrigerant from the refrigerant system and inspect the refrigerant oil content. Restore the refrigerant oil to the proper level, if required. 2. See Blend-air door motor in this group. Inspect the motor, and wire harness for proper installation and operation and correct, if required. 3. See Blend-Air Door under Heater-A/C Housing Door in this group. Inspect the blend-air door for proper operation and sealing. Correct if required.
The low side pressure is normal or slightly low, and the high side pressure is too low.	<ol style="list-style-type: none"> 1. Low refrigerant system charge. 2. Refrigerant flow through the accumulator is restricted. 3. Refrigerant flow through the evaporator coil is restricted. 4. Faulty compressor. 	<ol style="list-style-type: none"> 1. See Refrigerant System Leaks in this group. Test the refrigerant system for leaks. Repair, evacuate and charge the refrigerant system, if required. 2. See Accumulator in this group. Replace the restricted accumulator, if required. 3. See Evaporator Coil in this group. Replace the restricted evaporator coil, if required. 4. See Compressor in this group. Replace the compressor, if required.
The low side pressure is normal or slightly high, and the high side pressure is too high.	<ol style="list-style-type: none"> 1. Condenser air flow restricted. 2. Inoperative cooling fan. 3. Refrigerant system overcharged. 4. Air in the refrigerant system. 5. Engine overheating. 	<ol style="list-style-type: none"> 1. Check the condenser for damaged fins, foreign objects obstructing air flow through the condenser fins, and missing or improperly installed air seals. Refer to Group 7 - Cooling System for more information on air seals. Clean, repair, or replace components as required. 2. Refer to Group 7 - Cooling System for more information. Test the cooling fan and replace, if required. 3. See Refrigerant System Charge in this group. Recover the refrigerant from the refrigerant system. Charge the refrigerant system to the proper level, if required. 4. See Refrigerant System Leaks in this group. Test the refrigerant system for leaks. Repair, evacuate and charge the refrigerant system, if required. 5. Refer to Group 7 - Cooling System for more information. Test the cooling system and repair, if required.
The low side pressure is too high, and the high side pressure is too low.	<ol style="list-style-type: none"> 1. Accessory drive belt slipping. 2. Variable orifice tube not installed. 3. Faulty compressor. 	<ol style="list-style-type: none"> 1. Refer to Group 7 - Cooling System for more information. Inspect the accessory drive belt condition and tension. Tighten or replace the accessory drive belt, if required. 2. See Variable Orifice Tube in this group. Install the missing orifice tube and line if required. 3. See Compressor in this group. Replace the compressor, if required.

DIAGNOSIS AND TESTING (Continued)

Pressure Diagnosis		
Condition	Possible Causes	Correction
The low side pressure is too low, and the high side pressure is too high.	1. Restricted refrigerant flow through the refrigerant lines. 2. Restricted refrigerant flow through the variable orifice tube. 3. Restricted refrigerant flow through the condenser.	1. See Liquid Line and Suction and Discharge Line in this group. Inspect the refrigerant lines for kinks, tight bends or improper routing. Correct the routing or replace the refrigerant line, if required. 2. See Variable Orifice Tube in this group. Replace the restricted fixed orifice tube, if required. 3. See Condenser in this group. Replace the restricted condenser, if required.

AUTOMATIC ZONE CONTROL SYSTEM

The Automatic Zone Control (AZC) control module has a system self-diagnostic mode which continuously monitors various parameters during normal system operation. If a system fault is detected, a current and historical fault is recorded. When the current fault is cleared, the historical fault remains until reset (manually or automatically). Both the current and historical fault codes can be accessed through either the front panel, or over the Programmable Communications Interface (PCI) bus using a DRBIII® scan tool, and the proper Diagnostic Procedures manual.

The AZC control module is capable of three different types of self-diagnostic tests, as follows:

- Fault Code Tests
- Input Circuit Tests
- Output Circuit/Actuator Tests

The information that follows describes:

- How to read the self-diagnostic display
- How to enter the AZC control module self-diagnostic test mode
- How to select the self-diagnostic test types
- How to perform the different tests

ENTERING THE AZC SELF-DIAGNOSTIC MODE

To enter the AZC self-diagnostic mode, perform the following:

(1) Depress the A/C and Recirc buttons at the same time and hold. Rotate the left temperature control knob clockwise (CW) one detent.

(2) If you continue to hold the A/C and Recirc buttons depressed, the AZC control module will perform a Segment Test of the vacuum fluorescent (VF) display. In the Segment Test you should see all of the display segments illuminate as long as both buttons are held. If a display segment fails to illuminate, the vacuum fluorescent display is faulty and the heater-A/C control must be replaced.

(3) After viewing the Segment Test, release the A/C and Recirc buttons and the display will clear momentarily. If the display remains blank then no faults are set in the system. Should there be any faults, either "current" or "historical", all fault codes

will be displayed in ascending numerical sequence (note no effort is made to display fault codes in chronological order). Each fault code is displayed for one second before the next code is displayed. Once all fault codes have been displayed, the system will then repeat the fault code numbers. This will continue until the left side set temperature control is moved at least one detent position in the CW direction or the ignition is turned "OFF".

FAULT CODE TESTS

Fault codes are two-digit numbers that identify a circuit that is malfunctioning. There are two different kinds of fault codes.

1. **Current Fault Codes** - Current means the fault is present right now. There are two types of current faults: input faults, and system faults. If the system has a current fault when the ignition is turned "ON", or during normal operation a current fault occurs, the right side set temperature digits will display "ER" at maximum intensity, while the left side set temperature digits are blanked.

2. **Historical Fault Codes** - Historical or stored means that the fault occurred previously, but is not present right now. A majority of historical fault codes are caused by intermittent wire harness or wire harness connector problems.

NOTE: A battery disconnect will erase all faults stored in Random Access Memory (RAM) of the AZC control module. It is recommended that all faults be recorded before they are erased.

RETRIEVING FAULT CODES

(1) To begin the fault code tests, depress the A/C and Recirc buttons at the same time and rotate the left temperature control knob clockwise (CW) one detent, then release the push-button.

(2) **If there are no fault codes, the "00" display value will remain in the VF window.** Should there be any codes, each will be displayed for one second in ascending numerical sequence (note: no

DIAGNOSIS AND TESTING (Continued)

CURRENT FAULT CODES	
Input faults	01 = IR thermister circuit open
	02 = IR thermister circuit shorted
	03 = Fan pot shorted
	04 = Fan pot open
	05 = Mode pot shorted
	06 = Mode pot open
	07 = IR sensor delta too large
	08 = Reserved
	09 = Reserved
	10 = Reserved
	11 = Reserved
	12 = Reserved
System Faults	13 = AI (Recirc) motor not responding
	14 = Mode motor not responding
	15 = Left temperature door not responding
	16 = Right temperature door not responding
	17 = AI (Recirc) door travel too small
	18 = AI (Recirc) door travel too large
	19 = Mode door travel range too small
	20 = Mode door travel range too large
	21 = Left temperature door travel too small
	22 = Left temperature door travel too large
	23 = Right temperature door travel too small
	24 = Right temperature door travel too large
	25 = Calibration check sum error
	26 = Engine coolant temp bus message missing
	27 = Vehicle speed bus message missing
	28 = Engine RPM bus message missing
	29 = OAT bus message missing
	30 = Display intensity bus message missing
	31 = VIN number bus message missing
	32 = Reserved

effort is made to display faults in the order they occurred). The left side set temperature display will be blanked and the right side set temperature display will indicate current and historical codes (8 historical max) presently active. Once all codes have been displayed, the system will repeat the fault code numbers. This will continue until the left side set temperature control is moved at least one detent position in either direction, by pressing both the A/C and Recirc buttons at the same time, or the ignition is turned off. Record all of the fault codes, then see

the Current and Historical Fault Code charts for the descriptions.

CLEARING FAULT CODES

Current faults cannot be electronically cleared. Repair must be made to the system to eliminate the fault causing code. Historical fault codes can be cleared manually, or automatically. To clear a historical fault manually, depress and hold either the A/C or Recirc button for at least three seconds while the display is in the fault code mode of operation. Historical fault codes are cleared automatically when the

DIAGNOSIS AND TESTING (Continued)

HISTORICAL FAULT CODES	
Input faults	33 = IR thermister circuit was open
	34 = IR thermister circuit was shorted
	35 = Fan pot was shorted
	36 = Fan pot was open
	37 = Mode pot was shorted
	38 = Mode pot was open
	39 = IR sensor delta was too large
	40 = Reserved
	41 = Reserved
	42 = Reserved
	43 = Reserved
System Faults	44 = Reserved
	45 = AI (Recirc) motor was not responding
	46 = Mode motor was not responding
	47 = Left temperature door was not responding
	48 = Right temperature door was not responding
	49 = AI (Recirc) door travel was too small
	50 = AI (Recirc) door travel too large
	51 = Mode door travel range too small
	52 = Mode door travel range too large
	53 = Left temperature door travel too small
	54 = Left temperature door travel too large
	55 = Right temperature door travel too small
	56 = Right temperature door travel too large
	57 = Calibration check sum error
	58 = Engine coolant temp bus message missing
	59 = Vehicle speed bus message missing
	60 = Engine RPM bus message missing
	61 = OAT bus message missing
	62 = Display intensity bus message missing
	63 = VIN number bus message missing
64 = Reserved	
65 = Reserved	
66 = Reserved	
67 = Reserved	

corresponding current fault code has been cleared, and has remained cleared for a number of ignition cycles. The faults have been cleared when two horizontal bars appear in the Test Selector display.

EXITING SELF-DIAGNOSTIC MODE

The self-diagnostic mode can be exited by pressing both the A/C and Recirc buttons at the same time, or turning off the ignition.

MONITOR CURRENT PARAMETERS

While in the display fault code mode of operation, current system parameters can also be monitored and/or forced. Rotating the left side set temperature control clockwise will increase the pointer number while rotating the control counter clockwise will decrease the pointer number. Rotating the right set temperature control will have no impact on pointer

DIAGNOSIS AND TESTING (Continued)

value or the value of the parameter being monitored. Once the desired pointer number has been selected, pressing either the AC or Recirc buttons will display the current value of the selected parameter. **The right side set temperature display is only capable of displaying only values ranging from 0 to 99, the left side set temperature display is used for values greater than 99. If the value is less than 99, the left side set temperature display remains blanked.** While a parameter is being overridden, the system will continue to function normally except for the parameter which is being manually controlled.

On a limited number of pointers, pressing just the AC button, will cause the system to automatically increment the selected parameter values in step sizes determined by pointer 15 at a rate selected by pointer 16. Pressing just the Recirc button, will cause the system to automatically decrement the selected parameter values in step sizes determined by pointer 15 at a rate selected by pointer 16. On a pointer which this is not allowed, pressing either of these button will have no effect. Pressing and holding both the AC and recirculation buttons while rotating the left set temperature control either direction, will cause the system to exit the selected parameter and will maintain the override parameter value selected.

Rotating just left set temperature control without pressing any buttons will cause the system to revert back to automatic control of the selected parameter and will display the point number of the parameter just viewed. While displaying any pointer number and pressing both the AC and Recirc buttons will cause the system to exit the diagnostic mode of operation.

For values < 0, the "G" segment in the left side set temperature Most Significant Digit (MSD)(or left-most number in the pair) will be used to indicate a negative number. For values between -01 to -99 the Least Significant Digit (LSD)(or right-most number of the pair) in the left side set temperature will remain blank. System control of parameter being displayed can be overridden by rotating the right set temperature control in either direction. Rotating the right temperature control in the CW direction, the selected parameter value is overridden and incremented beginning at the value which was being displayed. Rotating the right temperature control in the CCW direction, the selected parameter value is overridden and decremented beginning at the value which was being displayed. The rate at which incrementing and decrement occurs is one unit value per set temperature detent position.

HVAC SYSTEM POINTER		
Pointer Number	DESCRIPTION	Value Displayed
01	A/C Enable	0 or 1
		0 = disabled 1 = enabled
02	Final fan PWM duty cycle	0 to 255
	While the value of this pointer is being displayed, turning the right set temperature control either direction will manually control the value. CW = increase; CCW = decrease	
	Pressing the AC button will cause the system to begin a sweep decrementing this variable beginning at the value being displayed just prior to the button press.	
	Pressing the Rec button will cause the system to begin a sweep incrementing this variable beginning at the value being displayed just prior to the button press.	
	The rate and step size of the sweep is controlled by the value set in pointers 15 and 16.	
03	Left NPRG	0 to 255
	While the value of this pointer is being displayed, turning the right set temperature control either direction will manually control the value. CW = increase; CCW = decrease	
	Pressing the AC button will cause the system to begin a sweep decrementing this variable beginning at the value being displayed just prior to the button press.	

DIAGNOSIS AND TESTING (Continued)

HVAC SYSTEM POINTER		
	Pressing the Rec button will cause the system to begin a sweep incrementing this variable beginning at the value being displayed just prior to the button press.	
	The rate and step size of the sweep is controlled by the value set in pointers 15 and 16.	
04	Right NPRG	0 to 255
	While the value of this pointer is being displayed, turning the right set temperature control either direction will manually control the value. CW = increase; CCW = decrease	
	Pressing the AC button will cause the system to begin a sweep decrementing this variable beginning at the value being displayed just prior to the button press.	
	Pressing the Rec button will cause the system to begin a sweep incrementing this variable beginning at the value being displayed just prior to the button press.	
	The rate and step size of the sweep is controlled by the value set in pointers 15 and 16.	
05	Avg NPRG	0 TO 255
	While the value of this pointer is being displayed, turning the right set temperature control either direction will manually control the value. CW = increase; CCW = decrease	
	Pressing the AC button will cause the system to begin a sweep decrementing this variable beginning at the value being displayed just prior to the button press.	
	Pressing the Rec button will cause the system to begin a sweep incrementing this variable beginning at the value being displayed just prior to the button press.	
	The rate and step size of the sweep is controlled by the value set in pointers 15 and 16.	
06	Primary control side	0 or 1 0 = left 1 = right
07	EE Check sum (calculated)	0 to 255
08	Target intensity (in % ON time)	0 to 255
	While the value of this pointer is being displayed, turning the right set temperature control either direction will manually control the value. CW = increase; CCW = decrease	
09	Not Used	0 to 0
10	number of indexes during ignition	0 to 255
	While the value of this pointer is being displayed, pressing the AC push button will zero the number of indexes during ignition OFF.	
11	Right NINC	0 to 255
	While the value of this pointer is being displayed, turning the right set temperature control either direction will manually control the value. CW = increase; CCW = decrease	
	Pressing the AC button will cause the system to begin a sweep decrementing this variable beginning at the value being displayed just prior to the button press.	

DIAGNOSIS AND TESTING (Continued)

HVAC SYSTEM POINTER		
	Pressing the Rec button will cause the system to begin a sweep incrementing this variable beginning at the value being displayed just prior to the button press.	
	The rate and step size of the sweep is controlled by the value set in pointers 15 and 16.	
12	Left NINC	0 to 255
	While the value of this pointer is being displayed, turning the right set temperature control either direction will manually control the value. CW = increase; CCW = decrease	
	Pressing the AC button will cause the system to begin a sweep decrementing this variable beginning at the value being displayed just prior to the button press.	
	Pressing the Rec button will cause the system to begin a sweep incrementing this variable beginning at the value being displayed just prior to the button press.	
	The rate and step size of the sweep is controlled by the value set in pointers 15 and 16.	
13	Right NMIX	0 to 255
	While the value of this pointer is being displayed, turning the right set temperature control either direction will manually control the value. CW = increase; CCW = decrease	
	Pressing the AC button will cause the system to begin a sweep decrementing this variable beginning at the value being displayed just prior to the button press.	
	Pressing the Rec button will cause the system to begin a sweep incrementing this variable beginning at the value being displayed just prior to the button press.	
	The rate and step size of the sweep is controlled by the value set in pointers 15 and 16.	
14	Left NMIX	0 to 255
	While the value of this pointer is being displayed, turning the right set temperature control either direction will manually control the value. CW = increase; CCW = decrease	
	Pressing the AC button will cause the system to begin a sweep decrementing this variable beginning at the value being displayed just prior to the button press.	
	Pressing the Rec button will cause the system to begin a sweep incrementing this variable beginning at the value being displayed just prior to the button press.	
	The rate and step size of the sweep is controlled by the value set in pointers 15 and 16.	
15	Scan Step Size	1 to 255
	The value displayed in this pointer is used to control step size used whenever the system is commanded (from the front panel) to conduct an automatic sweep. CW = increase; CCW = decrease; 0 is an illegal value min value =1	
16	Scan Step Time (in loop passes)	1 to 255
17	Reserved	

DIAGNOSIS AND TESTING (Continued)

HVAC SYSTEM POINTER		
18	Reserved	
19	Reserved	

MODE VALUE POINTER		
Pointer Number	DESCRIPTION	Value Displayed
20	mode range in delta counts	0 to 9999
21	Current mode position (in counts)	0 to 9999
22	mode target position in ratio	0 to 255
	While the value of this pointer is being displayed, turning the right set temperature control either direction will manually control the value. CW = increase; CCW = decrease	
	Pressing the AC button will cause the system to begin a sweep decrementing this variable beginning at the value being displayed just prior to the button press.	
	Pressing the Rec button will cause the system to begin a sweep incrementing this variable beginning at the value being displayed just prior to the button press.	
	The rate and step size of the sweep is controlled by the value set in pointers 15 and 16.	
23	mode target position in counts	0 to 9999
	While the value of this pointer is being displayed, turning the right set temperature control either direction will manually control the value. CW = increase; CCW = decrease	
24	elapsed time since last index in tenths of hours	0 to 255
25	number of valve moves since last index	0 to 9999
26	number of valve moves before last index	0 to 9999
27	number of ignition cycles since last index	0 to 255
28	number of ignition ON indexes	0 to 255
29	mode motor state	0 to 5
	While the value of this pointer is being displayed, pressing either the A/C or Recirc button will force the system to perform a calibration routine. 0 = searching range 1 = moving toward panel 2 = moving toward defrost 3 = in position 4 = stalled moving toward panel 5 = stalled moving toward defrost	

LEFT SIDE TEMPERATURE POINTER		
Pointer Number	DESCRIPTION	Value Displayed
30	Left side temp range in delta counts	0 to 9999
31	Current left side temp position (in counts)	0 to 9999
32	Left side temp target position (in ratio)	0 to 255
	While the value of this pointer is being displayed, turning the right set temperature control either direction will manually control the value. CW = increase; CCW = decrease	
	Pressing the AC button will cause the system to begin a sweep decrementing this variable beginning at the value being displayed just prior to the button press.	

DIAGNOSIS AND TESTING (Continued)

LEFT SIDE TEMPERATURE POINTER		
	Pressing the Rec button will cause the system to begin a sweep incrementing this variable beginning at the value being displayed just prior to the button press.	
	The rate and step size of the sweep is controlled by the value set in pointers 15 and 16.	
33	Left side temp target in counts	0 to 9999
	While the value of this pointer is being displayed, turning the right set temperature control either direction will manually control the value. CW = increase; CCW = decrease	
34	Elapsed time since last index in tenths of hours	0 to 255
35	number of valve moves since last index	0 to 9999
36	number of valve moves before last index	0 to 9999
37	number of ignition cycles since last index	0 to 255
38	number of ignition ON indexes	0 to 255
39	Left side temp motor state	0 to 5
	While the value of this pointer is being displayed, pressing either the A/C or Recirc button will force the system to perform a calibration routine. 0 = searching range 1 = moving toward panel 2 = moving toward defrost 3 = in position 4 = stalled moving toward panel 5 = stalled moving toward defrost	

RIGHT SIDE TEMPERATURE POINTER		
Pointer Number	DESCRIPTION	Value Displayed
40	Right side temp range in delta counts	0 to 9999
41	Current right side temp position (in counts)	0 to 9999
42	Right side temp target position (in ratio)	0 to 255
	While the value of this pointer is being displayed, turning the right set temperature control either direction will manually control the value. CW = increase; CCW = decrease	
	Pressing the AC button will cause the system to begin a sweep decrementing this variable beginning at the value being displayed just prior to the button press.	
	Pressing the Rec button will cause the system to begin a sweep incrementing this variable beginning at the value being displayed just prior to the button press.	
	The rate and step size of the sweep is controlled by the value set in pointers 15 and 16.	
43	Right side temp target in counts	0 to 9999
	While the value of this pointer is being displayed, turning the right set temperature control either direction will manually control the value. CW = increase; CCW = decrease	
44	Elapsed time since last index in tenths of hours	0 to 255
45	number of valve moves since last index	0 to 9999
46	number of valve moves before last index	0 to 9999
47	number of ignition cycles since last index	0 to 255
48	number of ignition ON indexes	0 to 255

DIAGNOSIS AND TESTING (Continued)

RIGHT SIDE TEMPERATURE POINTER		
49	Right side temp motor state	0 to 5
	While the value of this pointer is being displayed, pressing either the A/C or Recirc button will force the system to perform a calibration routine. 0 = searching range 1 = moving toward panel 2 = moving toward defrost 3 = in position 4 = stalled moving toward panel 5 = stalled moving toward defrost	

AIR INLET POINTER		
Pointer Number	DESCRIPTION	Value Displayed
50	Air inlet range (in counts)	0 to 9999
51	Current air inlet position (in counts)	0 to 9999
52	Air inlet target position (in ratio)	0 to 255
	While the value of this pointer is being displayed, turning the right set temperature control either direction will manually control the value. CW = increase; CCW = decrease	
	Pressing the AC button will cause the system to begin a sweep decrementing this variable beginning at the value being displayed just prior to the button press.	
	Pressing the Rec button will cause the system to begin a sweep incrementing this variable beginning at the value being displayed just prior to the button press.	
	The rate and step size of the sweep is controlled by the value set in pointers 15 and 16.	
53	Air inlet target in counts	0 to 9999
	While the value of this pointer is being displayed, turning the right set temperature control either direction will manually control the value. CW = increase; CCW = decrease	
54	Elapsed time since last index in tenths of hours	0 to 255
55	number of motor moves since last index	0 to 9999
56	number of motor moves before last index	0 to 9999
57	number of ignition cycles since last index	0 to 255
58	number of ignition ON indexes	0 to 255
59	Air inlet motor state	0 to 5
	While the value of this pointer is being displayed, pressing either the A/C or Recirc button will force the system to perform a calibration routine. 0 = searching range 1 = moving toward panel 2 = moving toward defrost 3 = in position 4 = stalled moving toward panel 5 = stalled moving toward defrost	
60	Reserved	
61	Actual Outside Air Temp (in degrees F)	-40 to 215
62	Engine Air Temp (in degrees F)	-40 to 215
63	Engine Intake Air Temperature (in degrees F)	-40 to 215
64	Vehicle speed in MPH	0 to 255
65	Engine RPM/100	-0 to 82
66	Engine Coolant Temp - 40 (in degrees F)	-40 to 215
67	Country Code	0 to 255

DIAGNOSIS AND TESTING (Continued)

AIR INLET POINTER		
68	User A/B	0, 1, 2
		0 = user A 1 = user B 2 = user undefined

IR SENSOR POINTER		
Pointer Number	DESCRIPTION	Value Displayed
70	Thermistor temp (in degrees)	-40 to 215
71	Left side sensor A/D (filtered)	0 to 255
72	Right side sensor A/D (filtered)	0 to 255
73	Left side temp (in degrees F)	-40 to 140
74	Right side temp (in degrees F)	-40 to 140

IDENTIFICATION POINTER		
Pointer Number	DESCRIPTION	Value Displayed
80	ROM bit pattern number (digits 1,2,3 & 4)	0 to 9999
81	ROM bit pattern number (digits 5,6,7 & 8)	0 to 9999
82	CAL bit pattern number (digits 1,2,3 & 4)	0 to 9999
83	CAL bit pattern number (digits 5,6,7 & 8)	0 to 9999
84	Software version Flash ROM	0 to 99
85	Software version revision	0 to 99
86	Not used	
87	Not used	
88	Not used	
89	Not used	

OUTPUT CIRCUIT/ACTUATOR TESTS

In the Output Circuit/Actuator Test mode, the output circuits can be viewed, monitored, overridden, and tested. If a failure occurs in an output circuit, test the circuit by overriding the system. Test the actuator through its full range of operation. When the override control has been activated, the Test Selector display will be flashing. The Test Selector will display feedback information about the output circuit being tested.

(1) To begin the Output Circuit/Actuator Tests you must be in the Select Test mode.

(2) With a "00" value displayed in the Test Selector and no stick man, turn the rotary temperature control knob until the test number you are looking for appears in the Test Selector display. See the Circuit Testing charts for a listing of the test numbers, test items, test types, system tested, and displayed values.

(3) To see the output value, depress the A/C or Recirc button. The values displayed will represent the output from the AZC control module.

(4) To enter the actuator test, depress the A/C or Recirc button. The Test Selector display will blink, indicating you are in the actuator test mode. Manual tests are those in which you will have to depress and hold the A/C or Recirc button to control the output. Automatic tests are those in which you will have to depress the A/C or Recirc button once to generate the output.

BLOWER MOTOR

WARNING: ON VEHICLES EQUIPPED WITH AIR-BAGS, REFER TO GROUP 8M - PASSIVE RESTRAINT SYSTEMS BEFORE ATTEMPTING ANY STEERING WHEEL, STEERING COLUMN, OR INSTRUMENT PANEL COMPONENT DIAGNOSIS OR SERVICE. FAILURE TO TAKE THE PROPER PRECAUTIONS COULD RESULT IN ACCIDENTAL AIR-BAG DEPLOYMENT AND POSSIBLE PERSONAL INJURY.

DIAGNOSIS AND TESTING (Continued)

For circuit descriptions and diagrams, refer to 8W-42 - Air Conditioning/Heater in Group 8W - Wiring Diagrams. Possible causes of an inoperative blower motor include:

- Faulty fuse
- Faulty blower motor circuit wiring or wire harness connections
- Faulty blower motor resistor (if the vehicle is so equipped)
- Faulty blower motor power module (if the vehicle is so equipped)

- Faulty blower motor switch
- Faulty heater-A/C mode control switch
- Faulty blower motor.

Possible causes of the blower motor not operating in all speeds include:

- Faulty fuse
- Faulty blower motor switch
- Faulty blower motor resistor (if the vehicle is so equipped)
- Faulty blower motor controller (power module) (if the vehicle is so equipped)
- Faulty AZC module (if the vehicle is so equipped)
- Faulty blower motor circuit wiring or wire harness connections.

VIBRATION

Possible causes of blower motor vibration include:

- Improper blower motor mounting
- Improper blower wheel mounting
- Blower wheel out of balance or bent
- Blower motor faulty.

NOISE

To verify that the blower is the source of the noise, unplug the blower motor wire harness connector and operate the heater-A/C system. If the noise goes away, possible causes include:

- Foreign material in the heater-A/C housing
- Improper blower motor mounting
- Improper blower wheel mounting
- Blower motor faulty.

BLOWER MOTOR RESISTOR

For circuit descriptions and diagrams, refer to 8W-42 - Air Conditioning/Heater in Group 8W - Wiring Diagrams.

WARNING: ON VEHICLES EQUIPPED WITH AIR-BAGS, REFER TO GROUP 8M - PASSIVE RESTRAINT SYSTEMS BEFORE ATTEMPTING ANY STEERING WHEEL, STEERING COLUMN, OR INSTRUMENT PANEL COMPONENT DIAGNOSIS OR SERVICE. FAILURE TO TAKE THE PROPER PRECAUTIONS COULD RESULT IN ACCIDENTAL AIR-

BAG DEPLOYMENT AND POSSIBLE PERSONAL INJURY.

(1) Disconnect and isolate the battery negative cable.

(2) Unplug the wire harness connector from the blower motor resistor.

(3) Check for continuity between each of the blower motor switch input terminals of the resistor and the resistor output terminal. In each case there should be continuity. If OK, repair the wire harness circuits between the blower motor switch and the blower motor resistor or blower motor as required. If not OK, replace the faulty blower motor resistor.

BLOWER MOTOR SWITCH

For circuit descriptions and diagrams, refer to 8W-42 - Air Conditioning/Heater in Group 8W - Wiring Diagrams.

WARNING: ON VEHICLES EQUIPPED WITH AIR-BAGS, REFER TO GROUP 8M - PASSIVE RESTRAINT SYSTEMS BEFORE ATTEMPTING ANY STEERING WHEEL, STEERING COLUMN, OR INSTRUMENT PANEL COMPONENT DIAGNOSIS OR SERVICE. FAILURE TO TAKE THE PROPER PRECAUTIONS COULD RESULT IN ACCIDENTAL AIR-BAG DEPLOYMENT AND POSSIBLE PERSONAL INJURY.

(1) Check for battery voltage at the fuse in the Power Distribution Center (PDC). If OK, go to Step 2. If not OK, repair the shorted circuit or component as required and replace the faulty fuse.

(2) Turn the ignition switch to the Off position. Disconnect and isolate the battery negative cable. Remove the heater-A/C control from the instrument panel. Check for continuity between the ground circuit cavity of the heater-A/C control wire harness connector and a good ground. There should be continuity. If OK, go to Step 3. If not OK, repair the open circuit to ground as required.

(3) With the heater-A/C control wire harness connector unplugged, place the heater-A/C mode control switch knob in any position except the Off position. Check for continuity between the ground circuit terminal and each of the blower motor driver circuit terminals of the heater-A/C control as you move the blower motor switch knob to each of the four speed positions. There should be continuity at each driver circuit terminal in only one blower motor switch speed position. If OK, test and repair the blower driver circuits between the heater-A/C control connector and the blower motor resistor as required. If not OK, replace the faulty heater-A/C control unit.

DIAGNOSIS AND TESTING (Continued)

COMPRESSOR

When investigating an air conditioning related noise, you must first know the conditions under which the noise occurs. These conditions include: weather, vehicle speed, transmission in gear or neutral, engine speed, engine temperature, and any other special conditions. Noises that develop during air conditioning operation can often be misleading. For example: What sounds like a failed front bearing or connecting rod, may be caused by loose bolts, nuts, mounting brackets, or a loose compressor clutch assembly.

Drive belts are speed sensitive. At different engine speeds and depending upon belt tension, belts can develop noises that are mistaken for a compressor noise. Improper belt tension can cause a misleading noise when the compressor clutch is engaged, which may not occur when the compressor clutch is disengaged. Check the serpentine drive belt condition and tension as described in Group 7 - Cooling System before beginning this procedure.

(1) Select a quiet area for testing. Duplicate the complaint conditions as much as possible. Switch the compressor on and off several times to clearly identify the compressor noise. Listen to the compressor while the clutch is engaged and disengaged. Probe the compressor with an engine stethoscope or a long screwdriver with the handle held to your ear to better localize the source of the noise.

(2) Loosen all of the compressor mounting hardware and retighten. Tighten the compressor clutch mounting nut. Be certain that the clutch coil is mounted securely to the compressor, and that the clutch plate and pulley are properly aligned and have the correct air gap. See Compressor and Compressor Clutch in the Removal and Installation section of this group for the procedures.

(3) To duplicate a high-ambient temperature condition (high head pressure), restrict the air flow through the condenser. Install a manifold gauge set to be certain that the discharge pressure does not exceed 2760 kPa (400 psi).

(4) Check the refrigerant system plumbing for incorrect routing, rubbing or interference, which can cause unusual noises. Also check the refrigerant lines for kinks or sharp bends that will restrict refrigerant flow, which can cause noises. See Suction and Discharge Line in the Removal and Installation section of this group for more information.

(5) If the noise is from opening and closing of the high pressure relief valve, evacuate and recharge the refrigerant system. See Refrigerant System Evacuate and Refrigerant System Charge in the Service Procedures section of this group. If the high pressure relief valve still does not seat properly, replace the compressor.

(6) If the noise is from liquid slugging on the suction line, replace the accumulator. See Accumulator in the Removal and Installation section of this group for the procedures. Check the refrigerant oil level and the refrigerant system charge. See Refrigerant Oil Level and Refrigerant System Charge in the Service Procedures section of this group. If the liquid slugging condition continues following accumulator replacement, replace the compressor.

(7) If the noise continues, replace the compressor and repeat Step 1.

COMPRESSOR CLUTCH COIL

For circuit descriptions and diagrams, refer to 8W-42 - Air Conditioning/Heater in Group 8W - Wiring Diagrams. The battery must be fully-charged before performing the following tests. Refer to Group 8A - Battery for more information.

(1) Connect an ammeter (0 to 10 ampere scale) in series with the clutch coil terminal. Use a voltmeter (0 to 20 volt scale) with clip-type leads for measuring the voltage across the battery and the compressor clutch coil.

(2) With the heater-A/C mode control switch in any A/C mode, the heater-A/C control A/C switch in the On position, and the blower motor switch in the lowest speed position, start the engine and run it at normal idle.

(3) The compressor clutch coil voltage should read within two volts of the battery voltage. If there is voltage at the clutch coil, but the reading is not within two volts of the battery voltage, test the clutch coil feed circuit for excessive voltage drop and repair as required. If there is no voltage reading at the clutch coil, use a DRBIII® scan tool and the proper Diagnostic Procedures manual for testing of the compressor clutch circuit. The following components must be checked and repaired as required before you can complete testing of the clutch coil:

- Fuses in the junction block and the Power Distribution Center (PDC)
- Heater-A/C mode control switch
- Compressor clutch relay
- High pressure switch
- Low pressure switch
- Powertrain Control Module (PCM)

(4) The compressor clutch coil is acceptable if the current draw measured at the clutch coil is 2.0 to 3.9 amperes with the electrical system voltage at 11.5 to 12.5 volts. This should only be checked with the work area temperature at 21° C (70° F). If system voltage is more than 12.5 volts, add electrical loads by turning on electrical accessories until the system voltage drops below 12.5 volts.

DIAGNOSIS AND TESTING (Continued)

- (a) If the clutch coil current reading is four amperes or more, the coil is shorted and should be replaced.
- (b) If the clutch coil current reading is zero, the coil is open and should be replaced.

COMPRESSOR CLUTCH RELAY

For circuit descriptions and diagrams, refer to 8W-42 - Air Conditioning/Heater in Group 8W - Wiring Diagrams.

The compressor clutch relay (Fig. 13) is located in the Power Distribution Center (PDC). Refer to the PDC label for relay identification and location. Remove the relay from the PDC to perform the following tests:

- (1) A relay in the de-energized position should have continuity between terminals 87A and 30, and no continuity between terminals 87 and 30. If OK, go to Step 2. If not OK, replace the faulty relay.
- (2) Resistance between terminals 85 and 86 (electromagnet) should be 75 ± 5 ohms. If OK, go to Step 3. If not OK, replace the faulty relay.
- (3) Connect a battery to terminals 85 and 86. There should now be continuity between terminals 30 and 87, and no continuity between terminals 87A and 30. If OK, see the Relay Circuit Test procedure in this group. If not OK, replace the faulty relay.

RELAY CIRCUIT TEST

For circuit descriptions and diagrams, refer to 8W-42 - Air Conditioning/Heater in Group 8W - Wiring Diagrams.

- (1) The relay common feed terminal cavity (30) is connected to fused battery feed. There should be battery voltage at the cavity for relay terminal 30 at all times. If OK, go to Step 2. If not OK, repair the open circuit to the fuse in the PDC as required.
- (2) The relay normally closed terminal (87A) is not used in this application. Go to Step 3.
- (3) The relay normally open terminal cavity (87) is connected to the compressor clutch coil. There should be continuity between this cavity and the A/C compressor clutch relay output circuit cavity of the compressor clutch coil wire harness connector. If OK, go to Step 4. If not OK, repair the open circuit as required.
- (4) The relay coil battery terminal (86) is connected to the fused ignition switch output (run/start) circuit. There should be battery voltage at the cavity for relay terminal 86 with the ignition switch in the On position. If OK, go to Step 5. If not OK, repair the open circuit to the fuse in the junction block as required.
- (5) The coil ground terminal cavity (85) is switched to ground through the Powertrain Control Module (PCM). There should be continuity between this cavity and the A/C compressor clutch relay control circuit cavity of the PCM wire harness connector C (gray) at all times. If not OK, repair the open circuit as required.

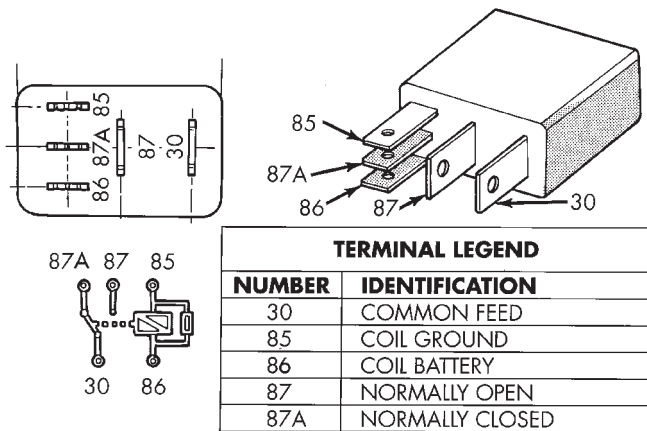

9514-16

Fig. 13 Compressor Clutch Relay

HEATER PERFORMANCE

Before performing the following tests, refer to Group 7 - Cooling System for the procedures to check the radiator coolant level, serpentine drive belt tension, radiator air flow and the radiator fan operation. Also be certain that the accessory vacuum supply line is connected at the engine intake manifold.

MAXIMUM HEATER OUTPUT

Engine coolant is delivered to the heater core through two heater hoses. With the engine idling at normal operating temperature, set the temperature control knob in the full hot position, the mode control switch knob in the floor heat position, and the blower motor switch knob in the highest speed position. Using a test thermometer, check the temperature of the air being discharged at the heater-A/C housing floor outlets. Compare the test thermometer reading to the Temperature Reference chart.

DIAGNOSIS AND TESTING (Continued)

Temperature Reference				
Ambient Air Temperature	15.5° C (60° F)	21.1° C (70° F)	26.6° C (80° F)	32.2° C (90° F)
Minimum Air Temperature at Floor Outlet	62.2° C (144° F)	63.8° C (147° F)	65.5° C (150° F)	67.2° C (153° F)

If the floor outlet air temperature is too low, refer to Group 7 - Cooling System to check the engine coolant temperature specifications. Both of the heater hoses should be hot to the touch. The coolant return heater hose should be slightly cooler than the coolant supply heater hose. If the return hose is much cooler than the supply hose, locate and repair the engine coolant flow obstruction in the cooling system. Refer to Group 7 - Cooling System for the procedures.

OBSTRUCTED COOLANT FLOW

Possible locations or causes of obstructed coolant flow:

- Pinched or kinked heater hoses.
- Improper heater hose routing.
- Plugged heater hoses or supply and return ports at the cooling system connections.
- A plugged heater core.

If proper coolant flow through the cooling system is verified, and heater outlet air temperature is still low, a mechanical problem may exist.

MECHANICAL PROBLEMS

Possible locations or causes of insufficient heat:

- An obstructed cowl air intake.
- Obstructed heater system outlets.
- A blend-air door not functioning properly.

TEMPERATURE CONTROL

If the heater outlet air temperature cannot be adjusted with the temperature control knob(s) on the heater-A/C control panel, the following could require service:

- The heater-A/C control.
- The blend-air door motor(s).
- The wire harness circuits for the heater-A/C control or the blend air door motor(s).
- The blend-air door(s).
- Improper engine coolant temperature.

HIGH PRESSURE SWITCH

Before performing diagnosis of the high pressure switch, verify that the refrigerant system has the correct refrigerant charge. See Refrigerant System Charge in the Service Procedures section of this group for more information.

For circuit descriptions and diagrams, refer to 8W-42 - Air Conditioning/Heater in Group 8W - Wiring Diagrams.

(1) Disconnect and isolate the battery negative cable.

(2) Unplug the wire harness connector from the high pressure switch on the refrigerant system fitting.

(3) Check for continuity between the two terminals of the high pressure switch. There should be continuity. If OK, test and repair the A/C switch sense circuit as required. If not OK, replace the faulty switch.

LOW PRESSURE SWITCH

Before performing diagnosis of the low pressure switch, be certain that the switch is properly installed on the accumulator fitting. If the switch is too loose it may not open the Schrader-type valve in the accumulator fitting, which will prevent the switch from correctly monitoring the refrigerant system pressure.

Also verify that the refrigerant system has the correct refrigerant charge. See Refrigerant System Charge in this group for the procedures.

For circuit descriptions and diagrams, refer to 8W-42 - Air Conditioning/Heater in Group 8W - Wiring Diagrams.

(1) Disconnect and isolate the battery negative cable.

(2) Unplug the low pressure switch wire harness connector from the switch on the accumulator fitting.

(3) Install a jumper wire between the two cavities of the low pressure switch wire harness connector.

(4) Connect a manifold gauge set to the refrigerant system service ports. See Refrigerant System Service Equipment in this group for the procedures.

(5) Connect the battery negative cable.

(6) Place the heater-A/C mode control switch knob in any A/C position and start the engine.

(7) Check for continuity between the two terminals of the low pressure switch. There should be continuity with a suction pressure reading of 262 kPa (38 psi) or above, and no continuity with a suction pressure reading of 141 kPa (20.5 psi) or below. If OK, test and repair the A/C switch sense circuit as required. If not OK, replace the faulty switch.

REFRIGERANT SYSTEM LEAKS

WARNING: REVIEW THE WARNINGS AND CAUTIONS IN THE FRONT OF THIS GROUP BEFORE LEAK TESTING THE SYSTEM.

DIAGNOSIS AND TESTING (Continued)

If the air conditioning system is not cooling properly, determine if the refrigerant system is fully-charged. See A/C Performance in this group for the procedures. If the refrigerant system is low or empty; a leak at a refrigerant line, connector fitting, component, or component seal is likely.

An electronic leak detector designed for R-134a refrigerant is recommended for locating and confirming refrigerant system leaks. Refer to the operating instructions supplied by the equipment manufacturer for proper care and use of this equipment.

An oily residue on or near refrigerant system lines, connector fittings, components, or component seals can indicate the general location of a possible refrigerant leak. However, the exact leak location should be confirmed with an electronic leak detector prior to component repair or replacement.

To detect a leak in the refrigerant system, perform one of the following procedures:

SYSTEM EMPTY

(1) Evacuate the refrigerant system. See Refrigerant System Evacuate in this group for the procedures.

(2) Connect and dispense 0.283 kilograms (0.625 pounds or 10 ounces) of R-134a refrigerant into the evacuated refrigerant system. See Refrigerant System Charge in this group for the procedures.

(3) Position the vehicle in a wind-free work area. This will aid in detecting small leaks.

(4) With the engine not running, use a electronic R-134a leak detector and search for leaks. Because R-134a refrigerant is heavier than air, the leak detector probe should be moved slowly along the bottom side of all refrigerant lines, connector fittings and components.

(5) To inspect the evaporator coil for leaks, insert the electronic leak detector probe into the center instrument panel outlet. Set the blower motor switch to the lowest speed position, the A/C button in the On position, and select the Recirculation Mode.

SYSTEM LOW

(1) Position the vehicle in a wind-free work area. This will aid in detecting small leaks.

(2) Bring the refrigerant system up to operating temperature and pressure. This is done by allowing the engine to run with the air conditioning system turned on for five minutes.

(3) With the engine not running, use a electronic R-134a leak detector and search for leaks. Because R-134a refrigerant is heavier than air, the leak detector probe should be moved slowly along the bottom side of all refrigerant lines, connector fittings and components.

(4) To inspect the evaporator coil for leaks, insert the electronic leak detector probe into the center instrument panel outlet. Set the blower motor switch to the lowest speed position, the A/C button in the On position, and select the Recirculation Mode.

SERVICE PROCEDURES

REFRIGERANT OIL LEVEL

When an air conditioning system is assembled at the factory, all components except the compressor are refrigerant oil free. After the refrigerant system has been charged and operated, the refrigerant oil in the compressor is dispersed throughout the refrigerant system. The accumulator, evaporator, condenser, and compressor will each retain a significant amount of the needed refrigerant oil.

It is important to have the correct amount of oil in the refrigerant system. This ensures proper lubrication of the compressor. Too little oil will result in damage to the compressor. Too much oil will reduce the cooling capacity of the air conditioning system.

It will not be necessary to check the oil level in the compressor or to add oil, unless there has been an oil loss. An oil loss may occur due to a rupture or leak from a refrigerant line, a connector fitting, a component, or a component seal. If a leak occurs, add 30 milliliters (1 fluid ounce) of refrigerant oil to the refrigerant system after the repair has been made. Refrigerant oil loss will be evident at the leak point by the presence of a wet, shiny surface around the leak.

Refrigerant oil must be added when a accumulator, evaporator coil, or condenser are replaced. See the Refrigerant Oil Capacities chart. When a compressor is replaced, the refrigerant oil must be drained from the old compressor and measured. Drain all of the refrigerant oil from the new compressor, then fill the new compressor with the same amount of refrigerant oil that was drained out of the old compressor.

Refrigerant Oil Capacities		
Component	ml	fl oz
A/C System	220	7.44
Accumulator	120	4
Condenser	30	1
Evaporator	60	2
Compressor	drain and measure the oil from the old compressor - see text.	

SERVICE PROCEDURES (Continued)

REFRIGERANT RECOVERY

WARNING: REVIEW THE WARNINGS AND CAUTIONS IN THE GENERAL INFORMATION SECTION NEAR THE FRONT OF THIS GROUP BEFORE RECOVERING REFRIGERANT.

A R-134a refrigerant recovery/recycling/charging station that meets SAE Standard J2210 must be used to recover the refrigerant from an R-134a refrigerant system. Refer to the operating instructions supplied by the equipment manufacturer for the proper care and use of this equipment.

REFRIGERANT SYSTEM CHARGE

WARNING: REVIEW THE WARNINGS AND CAUTIONS IN THE FRONT OF THIS GROUP BEFORE CHARGING THE REFRIGERANT SYSTEM.

After the refrigerant system has been tested for leaks and evacuated, a refrigerant charge can be injected into the system. See Refrigerant Charge Capacity for the proper amount of the refrigerant charge.

A R-134a refrigerant recovery/recycling/charging station that meets SAE Standard J2210 must be used to charge the refrigerant system with R-134a refrigerant. Refer to the operating instructions supplied by the equipment manufacturer for proper care and use of this equipment.

REFRIGERANT CHARGE CAPACITY

The R-134a refrigerant system charge capacity for this vehicle is 0.737 kilograms (1.625 pounds/26 ounces).

PARTIAL CHARGE METHOD

WARNING: REVIEW THE WARNINGS AND CAUTIONS IN THE FRONT OF THIS GROUP BEFORE CHARGING THE REFRIGERANT SYSTEM.

The partial charge method is used to add a partial charge to a refrigerant system that is low on refrigerant. To perform this procedure the evaporator inlet and outlet tube temperatures are measured. The temperature difference is measured with a temperature meter with one or two clamp-on thermocouple probes. The difference between the evaporator inlet and outlet tube temperatures will determine the amount of refrigerant needed.

Before adding a partial refrigerant charge, check for refrigerant system leaks. See Refrigerant System Leaks in this group for the procedures. If a leak is found, make the necessary repairs before attempting a full or partial refrigerant charge.

(1) Attach a manifold gauge set to the refrigerant system service ports.

(2) Attach the two clamp-on thermocouple probes to the inlet and outlet tubes of the evaporator coil.

a. If a single thermocouple probe is used, attach the probe to the evaporator inlet tube just before the collar of the refrigerant line connector fitting. The probe must make contact with the bottom surface of the evaporator inlet tube.

b. If dual thermocouple probes are used, attach probe 1 to the evaporator inlet tube, and probe 2 to the evaporator outlet tube. Attach both probes to the evaporator tubes just before the collar of the refrigerant line connector fittings. The probes must make contact with the bottom surfaces of the evaporator inlet and outlet tubes.

(3) Open all of the windows or doors of the passenger compartment.

(4) Set the A/C button on the heater-A/C controls to the on position, the temperature control knob in the full cool position, select the Recirculation Mode, and place the blower motor switch in the highest speed position.

(5) Start the engine and hold the engine idle speed at 1,000 rpm. Allow the engine to warm up to normal operating temperature.

(6) The compressor clutch may cycle, depending upon ambient temperature, humidity, and the refrigerant system charge level. If the compressor clutch cycles, unplug the wire harness connector from the low pressure cycling clutch switch on the accumulator. Install a jumper wire between the two cavities of the switch wire harness connector.

(7) Hold the engine idle speed at 1,000 rpm.

(8) Allow three to five minutes for the refrigerant system to stabilize, then record the temperatures of the evaporator inlet and outlet tubes.

c. If a single probe is used, record the temperature of the evaporator inlet tube. Then remove the probe from the inlet tube and attach it to the evaporator outlet tube just before the collar of the refrigerant line connector fitting. The probe must make contact with the bottom surface of the evaporator outlet tube. Allow the thermocouple and meter time to stabilize, then record the temperature of the evaporator outlet tube. Subtract the inlet tube temperature reading from the outlet tube temperature reading.

d. If dual probes are used, record the temperatures of both the evaporator inlet and outlet tubes. Then subtract the inlet tube temperature reading from the outlet tube temperature reading.

(9) See the Low Charge Determination chart to determine the additional charge required. If the measured temperature differential is higher than 22° C to 26° C (40° F to 47° F), add 0.4 kilograms (14 ounces) of refrigerant.

SERVICE PROCEDURES (Continued)

(10) Allow three to five minutes for the refrigerant system to stabilize, then take a second set of thermocouple measurements. Record the temperature difference and see the Low Charge Determination chart (Fig. 14) to determine if an additional charge is required.

(11) Record the compressor discharge pressure. If the reading is higher than the pressure shown in the Compressor Discharge Pressure chart (Fig. 15), the system could be overcharged. If the reading is equal to, or lower, than the pressure shown in the chart, continue with this procedure.

(12) **EXAMPLE:** The ambient temperature is 21° C (70° F). The evaporator inlet tube temperature is 12° C (54° F) and the evaporator outlet tube temperature is 10° C (50° F). Subtract the inlet tube temperature from the outlet tube temperature. The difference is -2° C (-4° F). With a -2° C (-4° F) tem-

perature differential at 21° C (70° F) ambient temperature, the system is fully charged.

(13) Add enough refrigerant to bring the refrigerant system up to a full charge.

(14) Remove the jumper wire from the low pressure cycling clutch switch wire harness connector and plug the connector back into the switch.

REFRIGERANT SYSTEM EVACUATE

WARNING: REVIEW THE WARNINGS AND CAUTIONS IN THE GENERAL INFORMATION SECTION NEAR THE FRONT OF THIS GROUP BEFORE EVACUATING THE SYSTEM.

If the refrigerant system has been open to the atmosphere, it must be evacuated before the system can be charged. If moisture and air enters the system and becomes mixed with the refrigerant, the com-

Open the windows and/or doors of the passenger compartment. Set the air conditioning controls to A/C, PANEL, RECIRC (temperature knob on full cool) and blower speed on HIGH. Set the engine speed at 1,000 RPM.

Evaporator Outlet and Inlet Temperature Differential					
<ul style="list-style-type: none"> • If Outlet is WARMER than Inlet, temperature differential is plus (+). • If Outlet is COLDER than Inlet, temperature differential is minus (-). <p>See the example in the Refrigerant Charge Check (Alternative Method).</p>					
Added Amount of R134a to Properly Charge A/C System	Ambient Temperature				
	21°C (70°F)	27°C (80°F)	32°C (90°F)	38°C (100°F)	43°C (110°F)
	Differential Temperature				
0.90 lbs. (14 oz.)	+22°C (+40°F)	+23°C (+42°F)	+24°C (+43°F)	+25°C (+45°F)	+26°C (+47°F)
0.75 lbs. (12 oz.)	+12°C (+22°F)	+12°C (+23°F)	+13°C (+24°F)	+15°C (+26°F)	+16°C (+28°F)
0.60 lbs. (10 oz.)	+4°C (+8°F)	+5°C (+9°F)	+6°C (+10°F)	+7°C (+12°F)	+8°C (+13°F)
0.50 lbs. (8 oz.)	0°C (0°F)	+0°C (+1°F)	+1°C (+2°F)	+2°C (+3°F)	+3°C (+4°F)
0.40 lbs. (6 oz.)	-1°C (-2°F)	-1°C (-1°F)	+0°C (-0°F)	0°C (0°F)	0°C (0°F)
Recommended Charge	-2 to -6°C (-3 to -10°F)				

Note: A temperature differential of -2°C to -6°C (-3°F to -10°F) indicates an acceptable charge.

Fig. 14 Low Charge Determination

SERVICE PROCEDURES (Continued)

Ambient Temperature	16°C (60°F)	21°C (70°F)	27°C (80°F)	32°C (90°F)	38°C (100°F)	43°C (110°F)
Compressor Discharge Pressure	1515 kPa (220 psi)	1655 kPa (240 psi)	1790 kPa (260 psi)	2070 kPa (300 psi)	2345 kPa (340 psi)	2690 kPa (390 psi)

J9324-40

Fig. 15 Compressor Discharge Pressure

pressor head pressure will rise above acceptable operating levels. This will reduce the performance of the air conditioner and damage the compressor. Evacuating the refrigerant system will remove the air and boil the moisture out of the system at near room temperature. To evacuate the refrigerant system, use the following procedure:

(1) Connect a R-134a refrigerant recovery/recycling/charging station that meets SAE Standard J2210 and a manifold gauge set to the refrigerant system of the vehicle.

(2) Open the low and high side valves and start the charging station vacuum pump. When the suction gauge reads 88 kPa (26 in. Hg.) vacuum or greater, close all of the valves and turn off the vacuum pump.

(a) If the refrigerant system fails to reach the specified vacuum, the system has a leak that must be corrected. See Refrigerant System Leaks in the Diagnosis and Testing section of this group for the procedures.

(b) If the refrigerant system maintains the specified vacuum for five minutes, restart the vacuum pump, open the suction and discharge valves and evacuate the system for an additional ten minutes.

(3) Close all of the valves, and turn off the charging station vacuum pump.

(4) The refrigerant system is now ready to be charged with R-134a refrigerant. See Refrigerant System Charge in the Service Procedures section of this group.

REMOVAL AND INSTALLATION

ACCUMULATOR

WARNING: REVIEW THE WARNINGS AND CAUTIONS IN THE FRONT OF THIS GROUP BEFORE PERFORMING THE FOLLOWING OPERATION.

The suction lines from the evaporator outlet tube to the accumulator, and from the accumulator to the suction port of the compressor manifold are integral to the accumulator. If either suction line or the accu-

mulator is faulty or damaged, the accumulator assembly must be replaced.

Any kinks or sharp bends in the refrigerant plumbing will reduce the capacity of the entire air conditioning system. Kinks and sharp bends reduce the flow of refrigerant in the system. A good rule for the flexible hose refrigerant lines is to keep the radius of all bends at least ten times the diameter of the hose. In addition, the flexible hose refrigerant lines should be routed so they are at least 80 millimeters (3 inches) from the exhaust manifold.

High pressures are produced in the refrigerant system when the air conditioning compressor is operating. Extreme care must be exercised to make sure that each of the refrigerant system connections is pressure-tight and leak free. It is a good practice to inspect all flexible hose refrigerant lines at least once a year to make sure they are in good condition and properly routed.

REMOVAL

(1) Disconnect and isolate the battery negative cable.

(2) Remove the low pressure cycling clutch switch from the accumulator. See Low Pressure Cycling Clutch Switch in this group for the procedures.

(3) Recover the refrigerant from the refrigerant system. See Refrigerant Recovery in this group for the procedures.

(4) Disconnect the suction line refrigerant line fitting from the evaporator outlet tube. Install plugs in, or tape over all of the opened refrigerant line fittings.

(5) Remove the screw that secures the suction line block fitting to the manifold on the compressor. Install plugs in, or tape over all of the opened refrigerant line fittings.

(6) Loosen the screw that clamps the band of the accumulator support bracket around the accumulator (Fig. 16).

(7) Remove the accumulator from the support bracket.

INSTALLATION

(1) Install the accumulator through the band of the support bracket. Be certain that the index tab on

REMOVAL AND INSTALLATION (Continued)

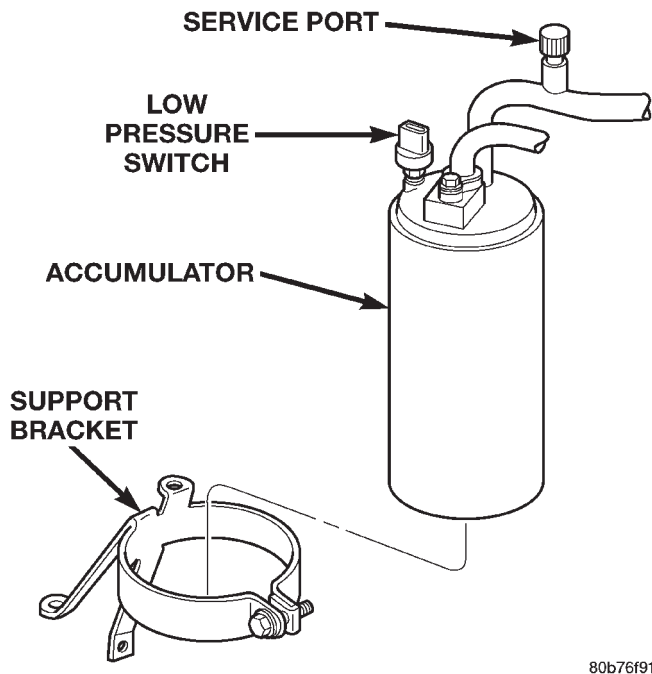

80b76f91

Fig. 16 Accumulator and Support Bracket

the side of the accumulator is aligned with the notch in the support bracket band.

(2) Tighten the clamp screw in the support bracket band to 12 N·m (105 in. lbs.).

(3) Remove the tape or plugs from the suction line block fitting and the manifold on the compressor. Install the suction line block fitting to the manifold on the compressor. Tighten the mounting screw to 28 N·m (250 in. lbs.).

(4) Remove the tape or plugs from the refrigerant line fittings on the suction line and the evaporator outlet tube.

(5) Install the low pressure cycling clutch switch onto the accumulator fitting. See Low Pressure Cycling Clutch Switch in this group for the procedures.

(6) Connect the battery negative cable.

(7) Evacuate the refrigerant system. See Refrigerant System Evacuate in this group for the procedures.

(8) Charge the refrigerant system. See Refrigerant System Charge in this group for the procedures.

NOTE: If the accumulator is replaced, add 120 milliliters (4 fluid ounces) of refrigerant oil to the refrigerant system. Use only refrigerant oil of the type recommended for the compressor in the vehicle.

BLEND-AIR DOOR(S)

WARNING: ON VEHICLES EQUIPPED WITH AIR-BAGS, REFER TO GROUP 8M - PASSIVE RESTRAINT SYSTEMS BEFORE ATTEMPTING ANY STEERING WHEEL, STEERING COLUMN, OR INSTRUMENT PANEL COMPONENT DIAGNOSIS OR SERVICE. FAILURE TO TAKE THE PROPER PRECAUTIONS COULD RESULT IN ACCIDENTAL AIR-BAG DEPLOYMENT AND POSSIBLE PERSONAL INJURY.

REMOVAL

(1) Remove the heater-A/C housing from the vehicle. See Heater-A/C Housing in this group for the procedures.

(2) Place the heater-A/C housing with the tubing side down on a work bench, making allowance for leakage of fluids.

(3) Using a sharp knife, split the foam seal surrounding the panel outlet opening, at the dividing line of the upper and lower cases (Fig. 17).

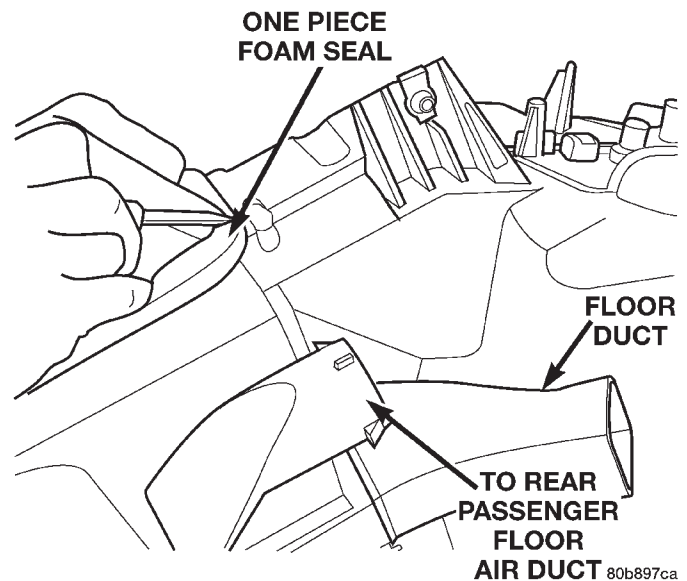

80b897ca

Fig. 17 Split Foam Seal at Panel Outlet

(4) Place the heater-A/C housing in the upright position on the work bench.

(5) Remove the mode door actuator on the left side of the housing, controlling the mode door in the top of the case (Fig. 18) (Fig. 19).

(6) Remove the screw with plastic washer holding the lever assembly to the upper case section, and move aside (Fig. 20).

(7) Remove the 5 clips that secure the two housing halves to each other. There are 2 on either side at the center, and 1 located at the forward end of the mode door side of the case (Fig. 21).

REMOVAL AND INSTALLATION (Continued)

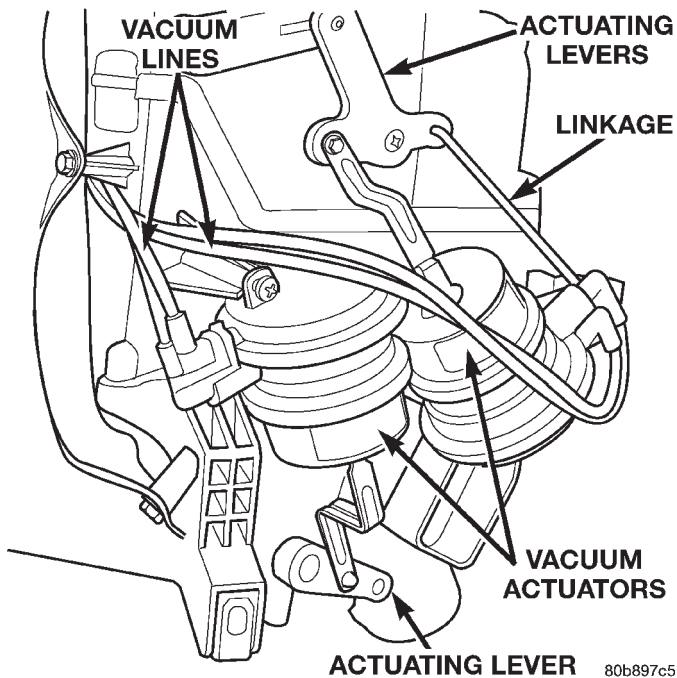

Fig. 18 Mode Door Actuators-Manual System

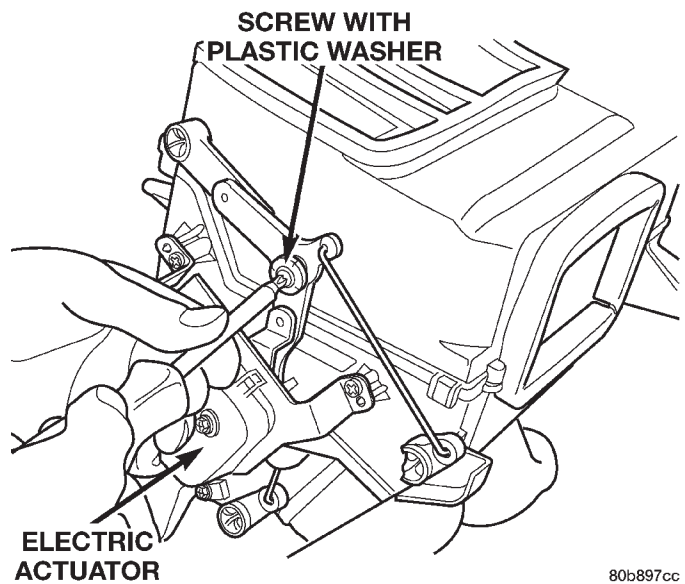

Fig. 20 Remove Screw with Plastic Washer

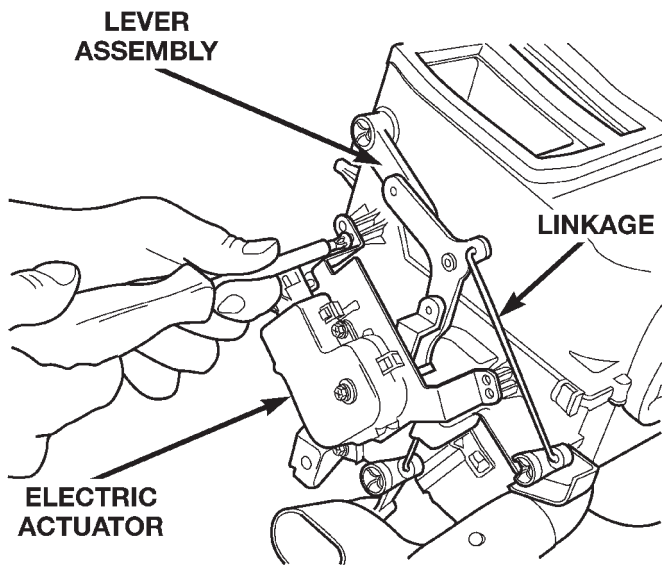

Fig. 19 Mode Door Actuator-AZC System

(8) Release the wire harness electrical connector(s) from the mounts on the lower case at the blower motor end of the unit (Fig. 22).

(9) Remove the 10 screws that secure the two housing halves to each other.

(10) Separate the top half of the heater-A/C housing from the bottom half (Fig. 23).

(11) Remove evaporator from lower case to ease access to plastic door shaft bushing.

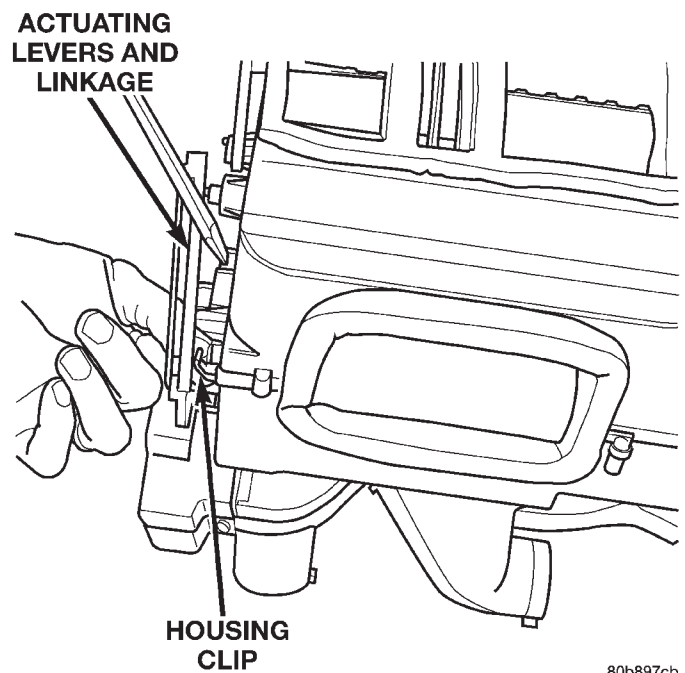

Fig. 21 HVAC Housing Clips

(12) Pinch the retention tabs holding the blend-air door pivot shaft bushing to the case. The 3 plastic tabs, located on the inside of the case, are part of the shaft retainer.

(13) Remove door(s).

NOTE: The blend-air door sub-assembly is attached to the housing with 2 screws, and may be removed for service (Fig. 24).

INSTALLATION

Reverse the removal procedures to install.

REMOVAL AND INSTALLATION (Continued)

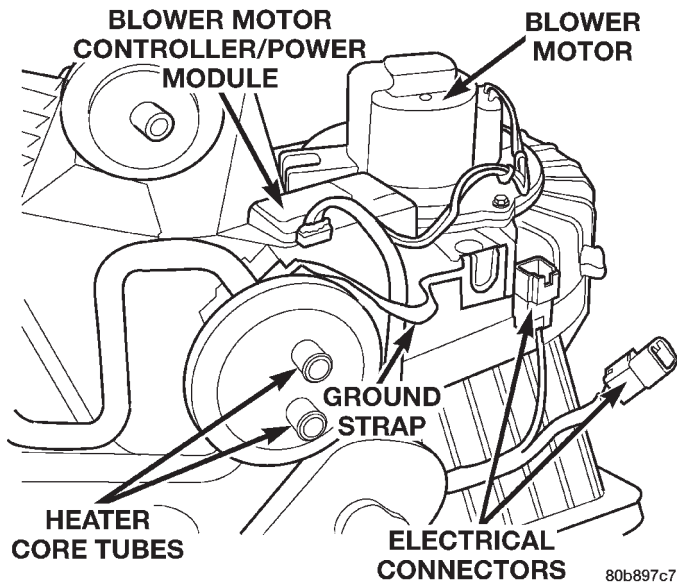

Fig. 22 Wire Harness Electrical Connector(s)

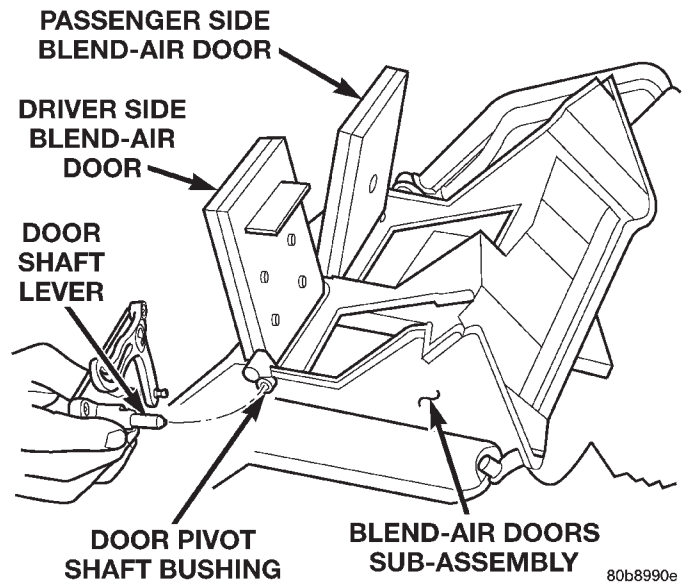

Fig. 24 Blend-Air Doors Sub-Assembly (AZC)

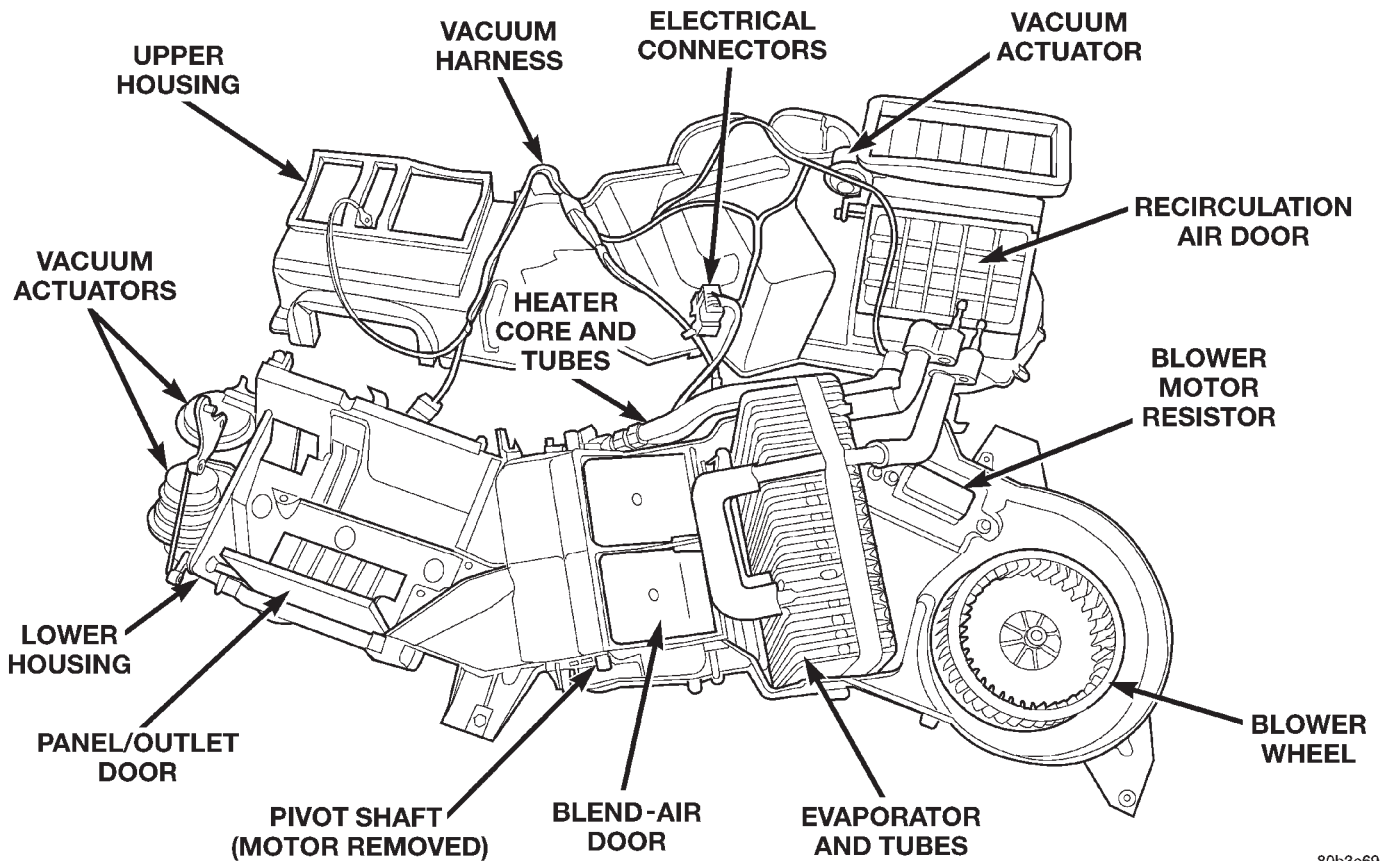

Fig. 23 Upper and Lower HVAC Housing-Separated

- Be certain that each of the door pivot pins align with the pivot holes in the heater-A/C housing.
- Tighten the heater-A/C housing screws to 2.2 N·m (20 in. lbs.).
- Check doors for binding after replacement, and after assembly of housing.

REMOVAL AND INSTALLATION (Continued)

BLOWER MOTOR

WARNING: ON VEHICLES EQUIPPED WITH AIRBAGS, REFER TO GROUP 8M - PASSIVE RESTRAINT SYSTEMS BEFORE ATTEMPTING ANY STEERING WHEEL, STEERING COLUMN, OR INSTRUMENT PANEL COMPONENT DIAGNOSIS OR SERVICE. FAILURE TO TAKE THE PROPER PRECAUTIONS COULD RESULT IN ACCIDENTAL AIRBAG DEPLOYMENT AND POSSIBLE PERSONAL INJURY.

REMOVAL

(1) Disconnect and isolate the battery negative cable.

(2) Pinch the connector retainer and unplug the blower motor wire harness from the heater-A/C blower motor (Fig. 25).

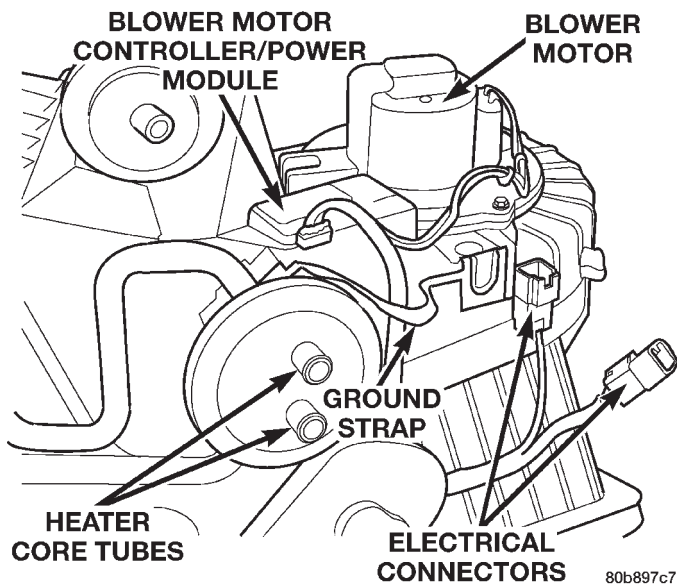

Fig. 25 Blower Motor (housing removed from vehicle)

(3) Remove the three screws that secure the blower motor and blower wheel assembly to the heater-A/C housing, using either a T-25 Torx® head or flat-bladed screwdriver.

(4) Lower the blower motor and wheel from the heater-A/C housing.

(5) Remove the blower wheel retainer clip (Fig. 26).

(6) Remove the wheel from the blower motor shaft.

INSTALLATION

(1) Press the blower wheel hub onto the blower motor shaft. Be sure the flat on the blower motor shaft is indexed to the flat on the inside of the blower wheel hub.

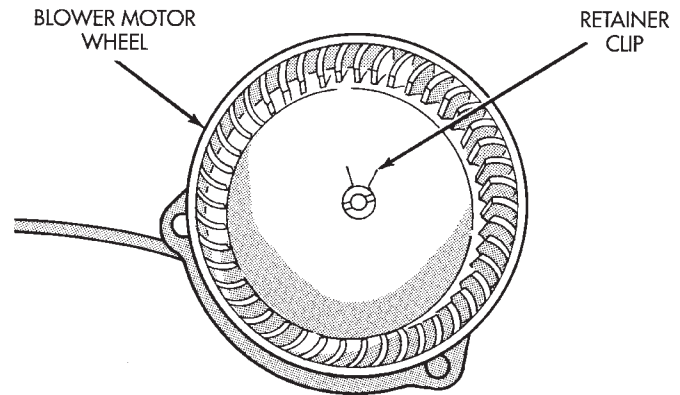

J9324-92

Fig. 26 Blower Motor Wheel Remove/Install

(2) Install the retainer clip over the blower wheel hub.

(3) Install the blower motor in the heater-A/C housing with three mounting screws. Tighten the mounting screws to 2.2 N·m (20 in. lbs.).

(4) Plug the blower motor wire harness connector into the blower motor socket.

(5) Connect the battery negative cable.

BLOWER MOTOR RESISTOR AND CONTROLLER

REMOVAL

(1) Disconnect and isolate the battery negative cable.

(2) Depress locking tab and unplug the wire harness connector from the blower motor resistor or controller (power module).

(3) Depress locking tab and unplug the resistor or controller connector from the blower motor.

(4) Remove the 2 screws that secure the blower motor resistor or controller to the heater-A/C housing.

(5) Remove the blower motor resistor or controller from the heater-A/C housing (Fig. 27).

INSTALLATION

(1) Install the blower motor resistor or controller to the heater-A/C housing. The housing is indexed to allow (controller/power module) mounting in only one position. Tighten the mounting screws to 2.2 N·m (20 in. lbs.).

(2) Plug in the wire harness connector to the blower motor resistor or controller.

(3) Plug in the connector from the blower motor resistor or controller to the blower motor.

(4) Connect the battery negative cable.

REMOVAL AND INSTALLATION (Continued)

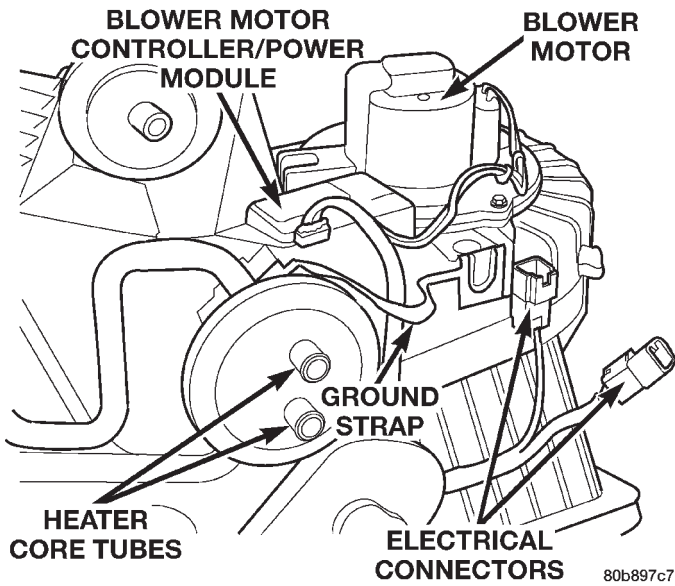

Fig. 27 Blower Motor Resistor or Controller/Power Module Remove/Install

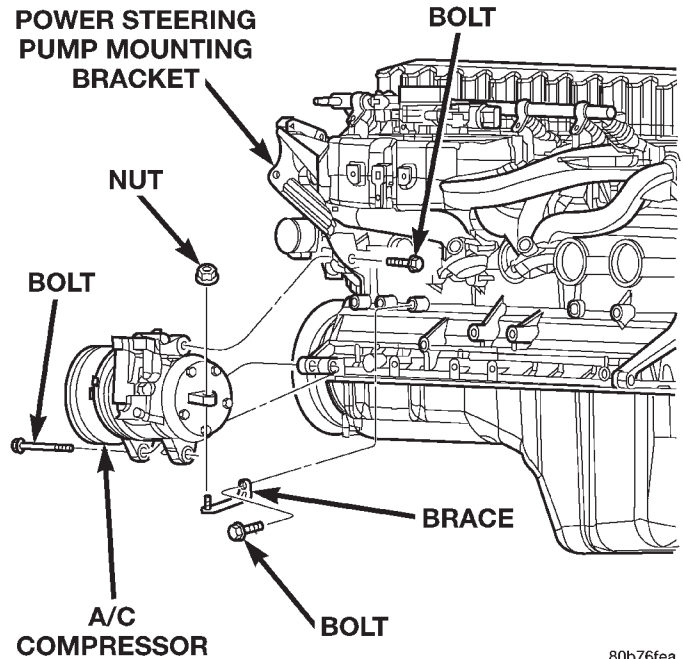

Fig. 28 Compressor Remove/Install - 6 Cylinder Engine

COMPRESSOR

The compressor may be removed and repositioned without disconnecting the refrigerant lines or discharging the refrigerant system. Discharging is not necessary if servicing the compressor clutch or clutch coil, the engine, the cylinder head, or the generator.

WARNING: REVIEW THE WARNINGS AND CAUTIONS IN THE FRONT OF THIS GROUP BEFORE PERFORMING THE FOLLOWING OPERATION.

REMOVAL

- (1) Recover the refrigerant from the refrigerant system. See Refrigerant Recovery in this group for the procedures.
- (2) Disconnect and isolate the battery negative cable.
- (3) Remove the serpentine drive belt. Refer to Group 7 - Cooling System for the procedures.
- (4) Unplug the compressor clutch coil wire harness connector.
- (5) Remove the screws that secure the suction line and discharge line block fittings to the manifold on the compressor. Install plugs in, or tape over all of the opened refrigerant fittings.
- (6) Remove the screws that secure the compressor (Fig. 28) or (Fig. 29) and (Fig. 30).
- (7) Remove the compressor.

INSTALLATION

NOTE: If a replacement compressor is being installed, be certain to check the refrigerant oil level. See Refrigerant Oil Level in this group for the

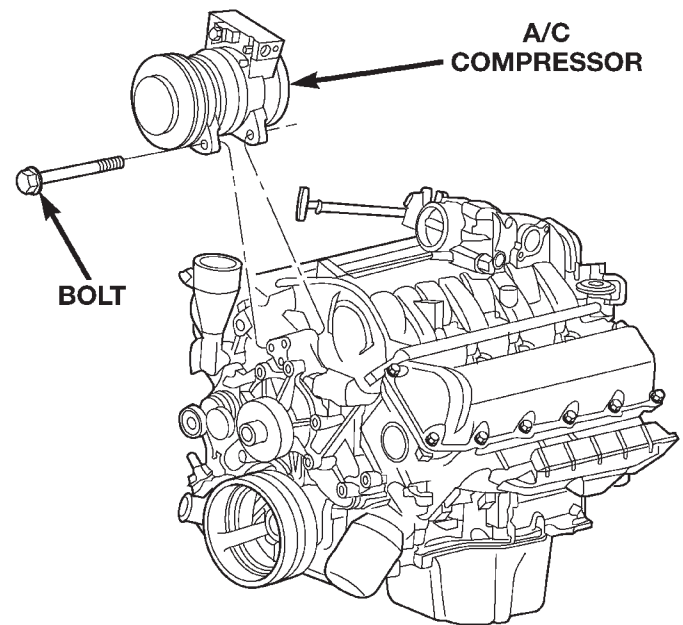

Fig. 29 Compressor Remove/Install - V8 Engine - Left View

procedures. Use only refrigerant oil of the type recommended for the compressor in the vehicle.

- (1) Install the compressor. Tighten the 4.0L mounting screws fastening the compressor to the block to 45-65 N·m (35-50 ft. lbs.). Tighten the mounting screws holding the rear brace to the compressor and block to 40-55 N·m (30-40 ft. lbs.).

REMOVAL AND INSTALLATION (Continued)

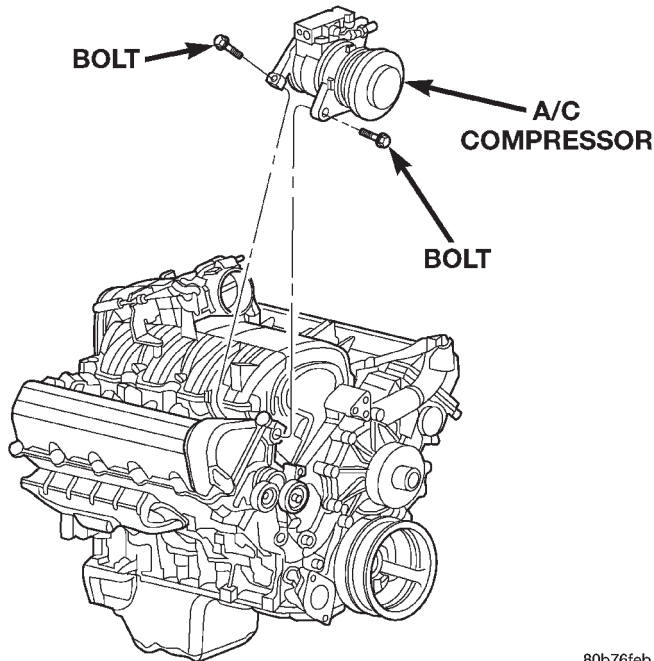

Fig. 30 Compressor Remove/Install - V8 Engine - Right View

80b76feb

Tighten the 4.7L compressor front mounting screws to 45-65 N·m (35-50 ft. lbs.), and the rear mounting screws to 35-45 N·m (25-35 ft. lbs.).

(2) Remove the tape or plugs from all of the opened refrigerant line fittings. Install the suction line and discharge line block fittings to the manifold on the compressor. Tighten the mounting screws to 25.4 N·m (225 in. lbs.).

(3) Install the serpentine drive belt. Refer to Group 7 - Cooling System for the procedures.

(4) Plug in the compressor clutch coil wire harness connector.

(5) Connect the battery negative cable.

(6) Evacuate the refrigerant system. See Refrigerant System Evacuate in this group for the procedures.

(7) Charge the refrigerant system. See Refrigerant System Charge in this group for the procedures.

COMPRESSOR CLUTCH

The refrigerant system can remain fully-charged during compressor clutch, pulley, or coil replacement. The compressor clutch can be serviced in the vehicle.

REMOVAL

(1) Disconnect and isolate the battery negative cable.

(2) Remove the serpentine drive belt. Refer to Group 7 - Cooling System for the procedures.

(3) Remove the bolt that secures the compressor clutch to the compressor shaft (Fig. 31). A band-type

oil filter wrench may be used to secure the clutch during bolt removal.

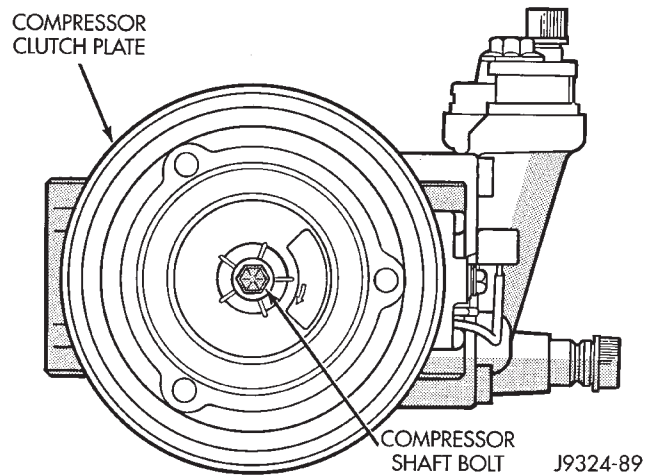

Fig. 31 Compressor Shaft Bolt

(4) Tap the clutch plate with a plastic mallet to release it from the splines on the compressor shaft. Remove the clutch plate and shim(s) from the compressor shaft (Fig. 32).

CAUTION: Do not pry between the clutch plate assembly and the pulley to remove it from the compressor shaft. Prying may damage the clutch plate assembly.

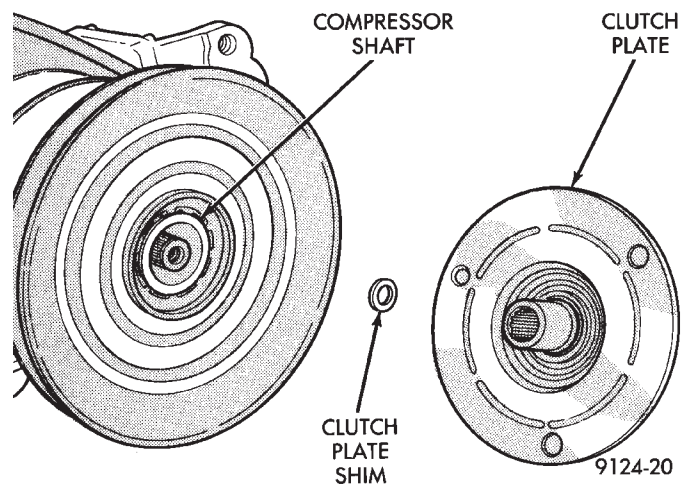

Fig. 32 Clutch Plate and Shim

(5) Remove the external snap ring that secures the compressor clutch pulley to the nose of the compressor front housing with snap ring pliers (Special Tool C-4574) and slide the pulley assembly off of the compressor (Fig. 33).

(6) Remove the screw and retainer from the clutch coil lead wire harness on the compressor front housing.

(7) Remove the external snap ring that secures the compressor clutch coil to the nose of the compressor front housing with snap ring pliers and slide the coil assembly off of the compressor (Fig. 34).

REMOVAL AND INSTALLATION (Continued)

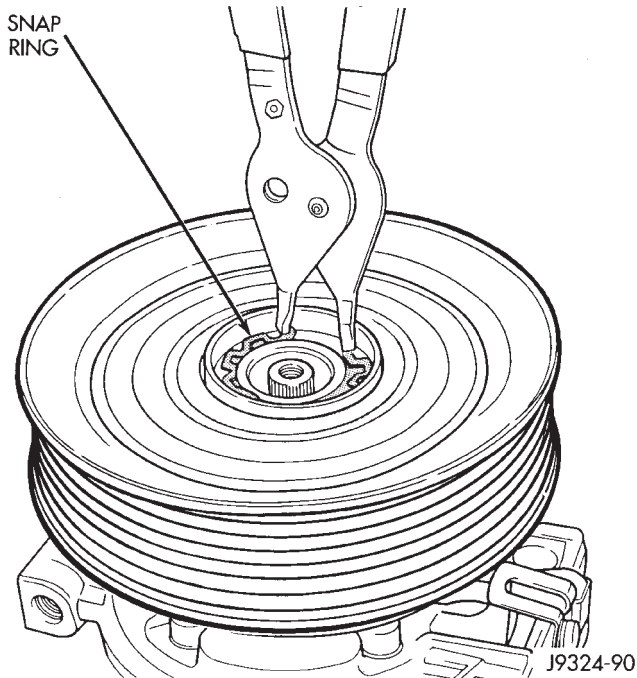

Fig. 33 Pulley Snap Ring Remove/Install

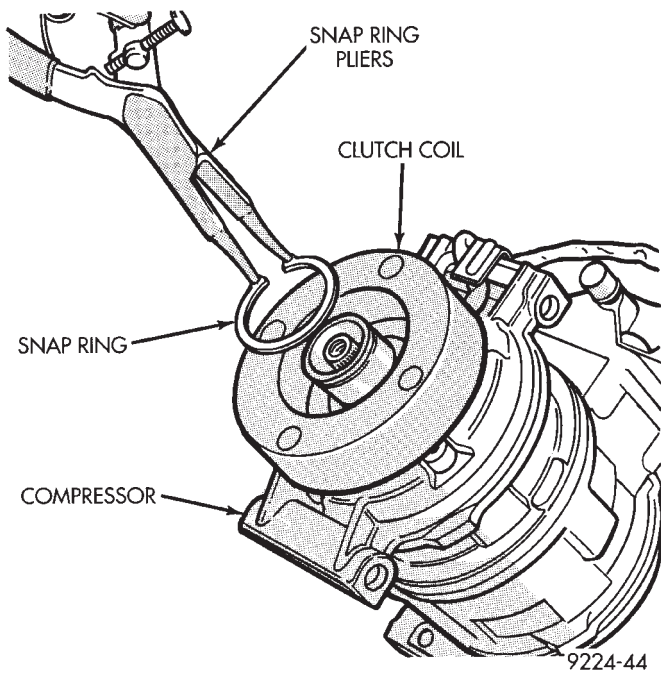

Fig. 34 Clutch Coil Snap Ring Remove/Install

INSPECTION

Examine the friction surfaces of the clutch pulley and the clutch plate for wear. The pulley and plate should be replaced if there is excessive wear or scoring.

If the friction surfaces are oily, inspect the shaft and nose area of the compressor for refrigerant oil. Remove the felt wick from around the shaft inside the nose of the compressor front housing. If the felt

is saturated with refrigerant oil, the compressor shaft seal is leaking and the compressor must be replaced.

Check the clutch pulley bearing for roughness or excessive leakage of grease. Replace the bearing, if required.

INSTALLATION

(1) Align the dowel pin on the back of the clutch field coil with the hole in the compressor front housing and press the field coil into place over the nose of the compressor.

(2) Install the clutch coil lead wire harness retaining clip on the compressor front housing and tighten the retaining screw.

(3) Install the clutch field coil and snap ring with snap ring pliers (Special Tool C-4574). The bevel side of the snap ring must be facing outward. Also, both eyelets of the snap ring must be to the right or left of the pin on the compressor. Press in on the snap ring to be certain that it is properly seated in the groove.

CAUTION: If the snap ring is not fully seated in the groove it will vibrate out, resulting in a clutch failure and severe damage to the front housing of the compressor.

(4) Install the pulley assembly onto the compressor. If necessary, place a block of wood on the friction surface and tap gently with a hammer (Fig. 35).

CAUTION: Do not mar the pulley friction surface.

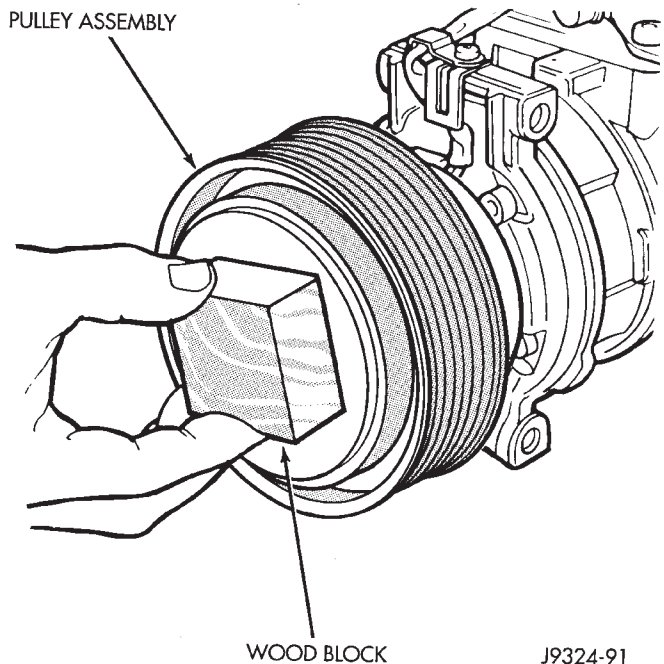

Fig. 35 Pulley Assembly Install

REMOVAL AND INSTALLATION (Continued)

(5) Install the pulley assembly retaining snap ring (bevel side outward) with snap ring pliers (Special Tool C-4574). Press in on the snap ring to be certain that it is properly seated in the groove.

(6) If the original clutch plate assembly and pulley assembly are to be reused, the old shim(s) can be used. If not, place a stack of shim(s) equal to the old shim(s) on the shaft against the shoulder.

(7) Install the clutch plate assembly onto the shaft.

(8) With the clutch plate assembly tight against the shim(s), measure the air gap between the clutch plate and the pulley face with feeler gauges. The air gap should be between 0.35 to 0.65 millimeter (0.014 to 0.026 inch). If the proper air gap is not obtained, add or subtract shims as needed until the desired air gap is obtained.

(9) Install the compressor shaft bolt. Tighten the bolt to 13 N·m (115 in. lbs.).

NOTE: The shims may compress after tightening the shaft bolt. Check the air gap in four or more places to verify the air gap is still correct. Spin the pulley before performing a final check of the air gap.

(10) Reverse the remaining removal procedures to complete the installation.

CLUTCH BREAK-IN

After a new compressor clutch has been installed, cycle the compressor clutch approximately twenty times (five seconds on, then five seconds off). During this procedure, set the heater-A/C control in the Recirculation Mode, the A/C button in the on position, the blower motor switch in the highest speed position, and the engine speed at 1500 to 2000 rpm. This procedure (burnishing) will seat the opposing friction surfaces and provide a higher compressor clutch torque capability.

COMPRESSOR CLUTCH RELAY

(1) Disconnect and isolate the battery negative cable.

(2) Remove the cover from the Power Distribution Center (PDC) (Fig. 36).

(3) Refer to the label on the PDC for compressor clutch relay identification and location.

(4) Unplug the compressor clutch relay from the PDC.

(5) Install the compressor clutch relay by aligning the relay terminals with the cavities in the PDC and pushing the relay firmly into place.

(6) Install the PDC cover.

(7) Connect the battery negative cable.

(8) Test the relay operation.

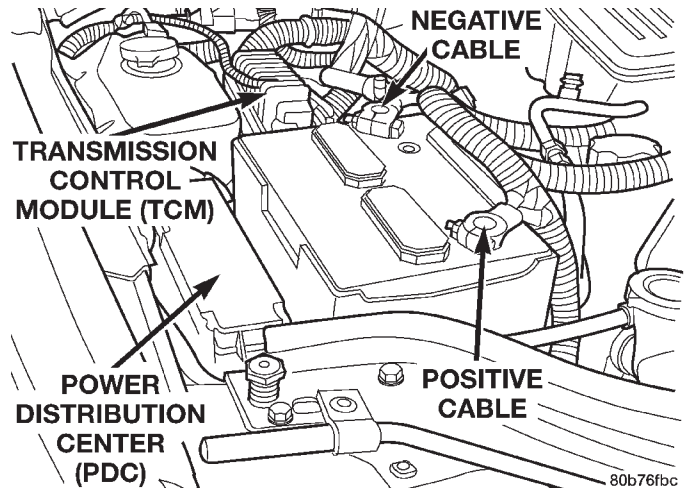

Fig. 36 Power Distribution Center (PDC)

CONDENSER

WARNING: REVIEW THE WARNINGS AND CAUTIONS IN THE FRONT OF THIS GROUP BEFORE PERFORMING THE FOLLOWING OPERATION.

CAUTION: Before removing the condenser, note the location of each of the radiator and condenser air seals. These seals are used to direct air through the condenser and radiator. The air seals must be reinstalled in their proper locations in order for the air conditioning and engine cooling systems to perform as designed (Fig. 37).

REMOVAL

(1) Disconnect and isolate the battery negative cable.

(2) Recover the refrigerant from the refrigerant system. See Refrigerant Recovery in this group for the procedures.

(3) Remove the screws attaching the grille and headlamp mounting module to the upper crossmember of the vehicle. Refer to Group 23 - Body for this and further steps in the procedure.

(4) Remove the headlamps from their mounts.

(5) Remove the nuts that secure the hood latch and brace to the upper crossmember.

(6) The radiator upper crossmember can be adjusted left or right through the use of its slotted mounting holes. Before removal, mark the original position of the crossmember.

(7) Remove the bolts that secure the radiator to the upper crossmember and set it aside (Fig. 38).

(8) Remove the engine air filter inlet duct secured at the headlamp mounting module.

(9) Remove the headlamp mounting module and front fascia for access to the condenser and fittings.

REMOVAL AND INSTALLATION (Continued)

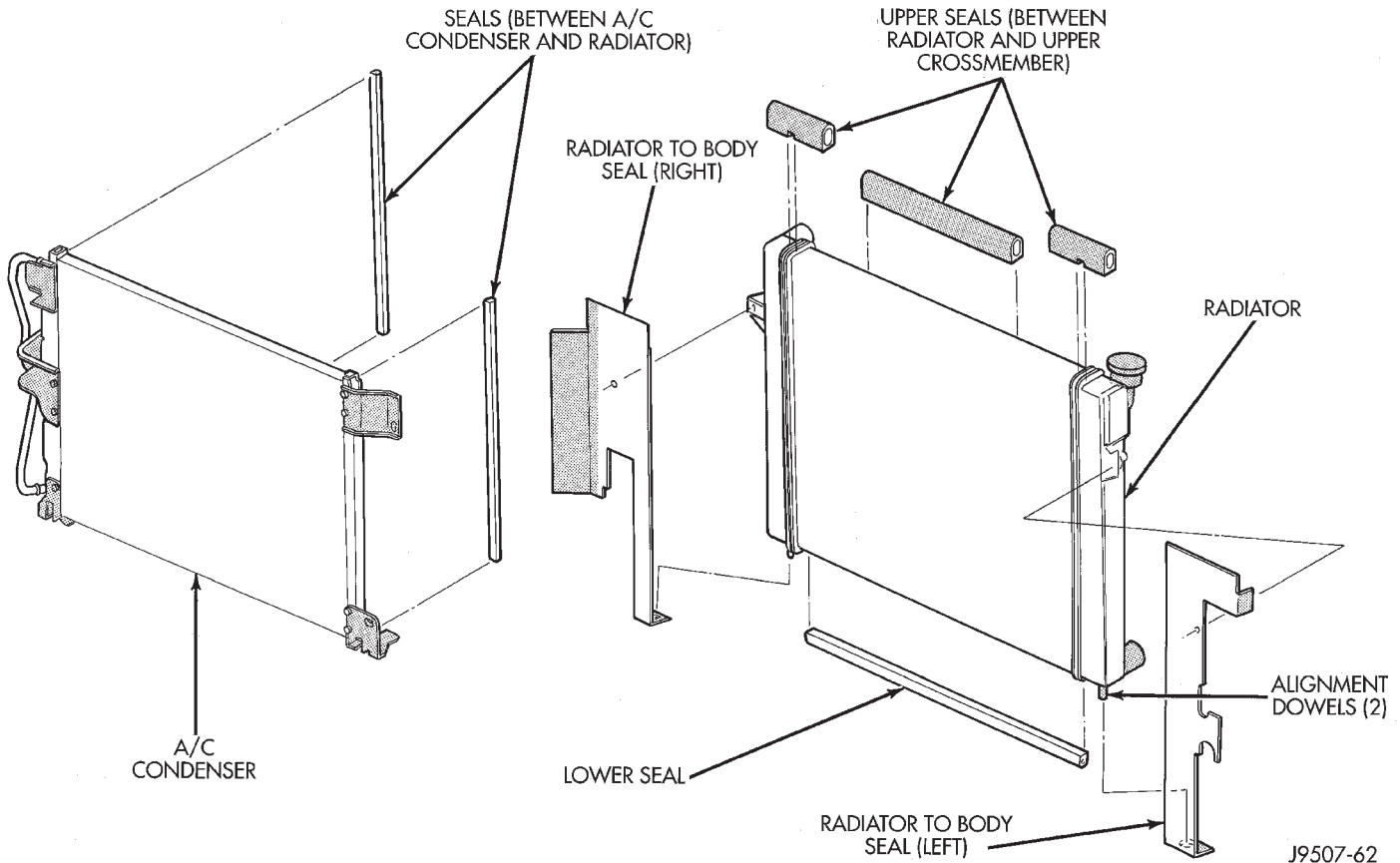

Fig. 37 Air Seals - Typical

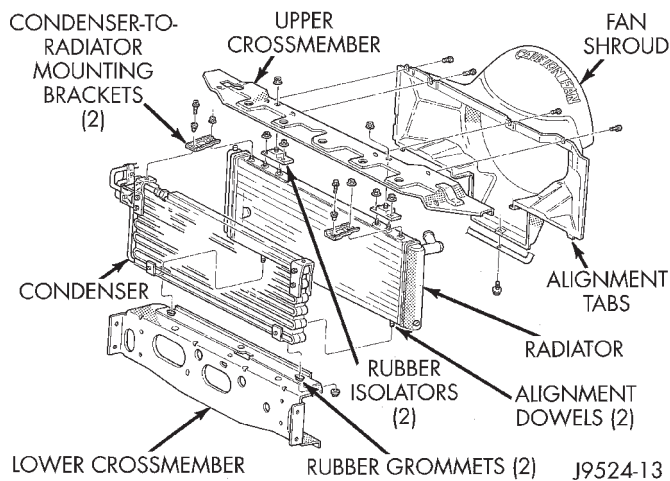

Fig. 38 Condenser Mounting - Typical

(10) Disconnect the discharge line and liquid line refrigerant line fittings from the condenser. See Refrigerant Line Coupler in this group for the procedures. Install plugs in, or tape over all of the opened refrigerant line fittings.

(11) Remove the bolts that secure the upper condenser and transmission cooler.

(12) Carefully lift the condenser out of the vehicle.

INSTALLATION

For installation, reverse the above procedures.

- Carefully position the condenser in the vehicle.
- Remove the tape or plugs from the refrigerant line fittings on the discharge line, liquid line and the condenser. Connect both of the refrigerant line couplers to the condenser. See Refrigerant Line Coupler in this group for the procedures.
- Evacuate and charge the refrigerant system. See Refrigerant System Evacuate and Charge procedures in this group.

NOTE: If the condenser is replaced, add 30 milliliters (1 fluid ounce) of refrigerant oil to the refrigerant system. Use only refrigerant oil of the type recommended for the compressor in the vehicle.

DISCHARGE LINE

Any kinks or sharp bends in the refrigerant plumbing will reduce the capacity of the entire air conditioning system. Kinks and sharp bends reduce the flow of refrigerant in the system. A good rule for the flexible hose refrigerant lines is to keep the radius of all bends at least ten times the diameter of the hose. In addition, the flexible hose refrigerant lines should be routed so they are at least 80 millimeters (3 inches) from the exhaust manifold.

REMOVAL AND INSTALLATION (Continued)

High pressures are produced in the refrigerant system when the air conditioning compressor is operating. Extreme care must be exercised to make sure that each of the refrigerant system connections is pressure-tight and leak free. It is a good practice to inspect all flexible hose refrigerant lines at least once a year to make sure they are in good condition and properly routed.

WARNING: REVIEW THE WARNINGS AND CAUTIONS IN THE FRONT OF THIS GROUP BEFORE PERFORMING THE FOLLOWING OPERATION.

REMOVAL

- (1) Disconnect and isolate the battery negative cable.
- (2) Recover the refrigerant from the refrigerant system. See Refrigerant Recovery in this group for the procedures.
- (3) Remove the high pressure cut-off switch. See High Pressure Cut-Off Switch in this group for the procedures.
- (4) Disconnect the discharge line refrigerant line fitting from the condenser inlet tube. Install plugs in, or tape over all of the opened refrigerant line fittings.
- (5) Remove the screw that secures the discharge line block fitting to the manifold on the compressor. Install plugs in, or tape over all of the opened refrigerant line fittings.
- (6) Remove the discharge line assembly from the vehicle.

INSTALLATION

- (1) Remove the tape or plugs from the discharge line block fitting and the manifold on the compressor. Install the discharge line block fitting to the manifold on the compressor. Tighten the mounting screw to 25.4 N·m (225 in. lbs.).
- (2) Remove the tape or plugs from the refrigerant line fittings on the discharge line and the condenser

inlet tube. Connect the discharge line refrigerant line coupler to the condenser inlet tube.

(3) Install the high pressure cut-off switch. See High Pressure Cut-Off Switch in this group for the procedures.

(4) Connect the battery negative cable.

(5) Evacuate the refrigerant system. See Refrigerant System Evacuate in this group for the procedures.

(6) Charge the refrigerant system. See Refrigerant System Charge in this group for the procedures.

DUCTS AND OUTLETS

DEFROSTER DUCT

(1) Remove the instrument panel assembly from the vehicle. See Instrument Panel Assembly in Group 8E - Instrument Panel Systems for the procedures.

(2) Remove the three screws that secure the defroster duct to the HVAC unit housing (Fig. 39).

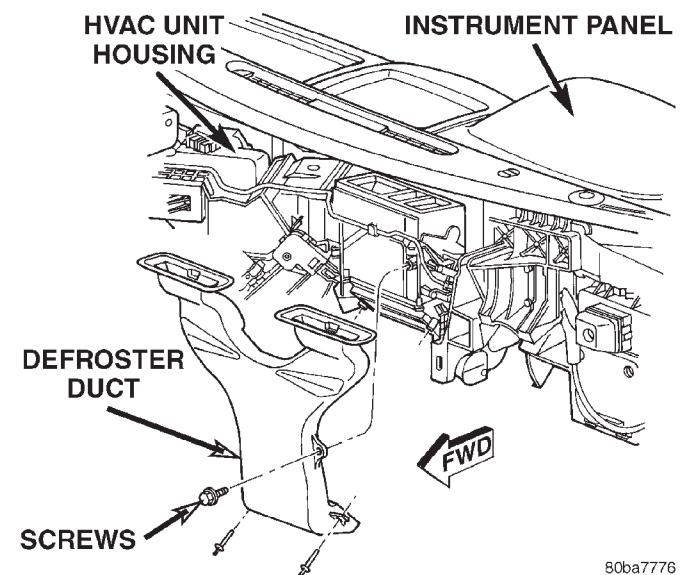

80ba7776

Fig. 39 HVAC Defroster Duct

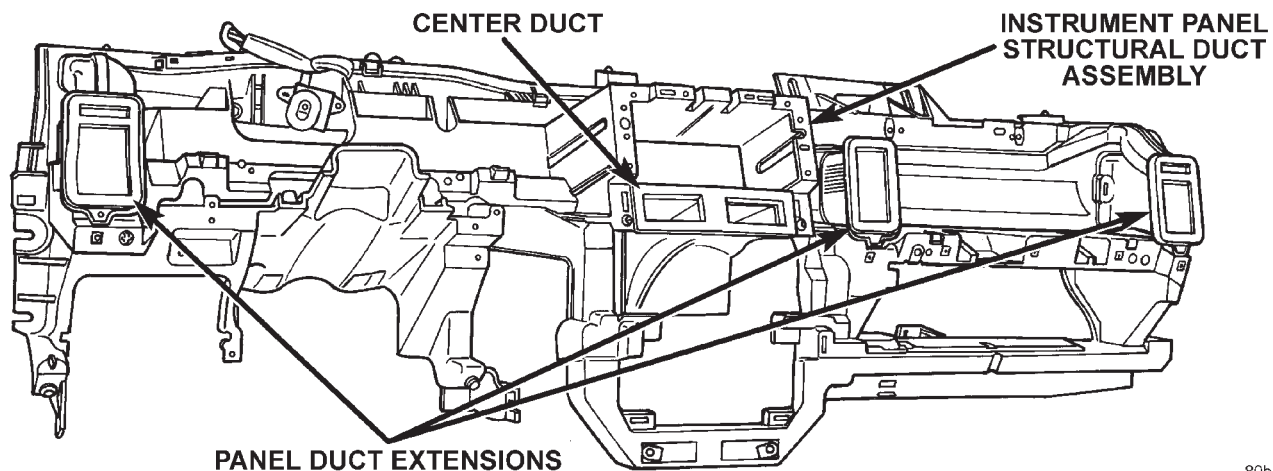

80b46c5b

Fig. 40 Instrument Panel Structural Duct Assembly

REMOVAL AND INSTALLATION (Continued)

(3) Remove the defroster duct from the HVAC unit housing.

(4) Reverse the removal procedures to install. Tighten the mounting screws to 2.2 N·m (20 in. lbs.).

INSTRUMENT PANEL DUCT EXTENSIONS

(1) Remove the instrument panel top pad from the vehicle. See Instrument Panel Assembly in Group 8E - Instrument Panel Systems for the procedure.

(2) Unsnap the duct extension(s) from the instrument panel structural duct assembly (Fig. 40).

(3) Remove the duct extension(s) from the instrument panel (Fig. 41).

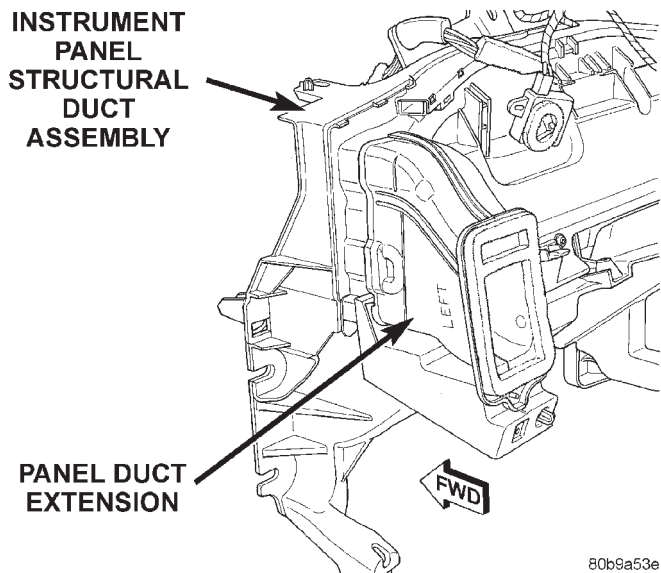

Fig. 41 Instrument Panel Duct Extension

(4) Reverse the removal procedures to install.

FLOOR DUCTS

(1) To remove the driver side floor duct from the vehicle, remove the knee blocker panel for access to attaching screw. See Instrument Panel Assembly in Group 8E - Instrument Panel Systems for the procedures.

(2) The passenger side floor duct fastener can be accessed under the right-center instrument panel.

(3) Remove the screw that secures the floor duct(s) to the HVAC housing (Fig. 42).

(4) Reverse the removal procedures to install. Tighten the mounting screws to 2.2 N·m (20 in. lbs.).

REAR FLOOR DUCTS

(1) To remove the rear floor ducts from the vehicle, remove the knee blocker panels for access, and pull carpeting back.

(2) Pull the floor ducts from the HVAC housing (Fig. 43).

NOTE: The ductwork running from the HVAC housing rearward through the passenger compartment is

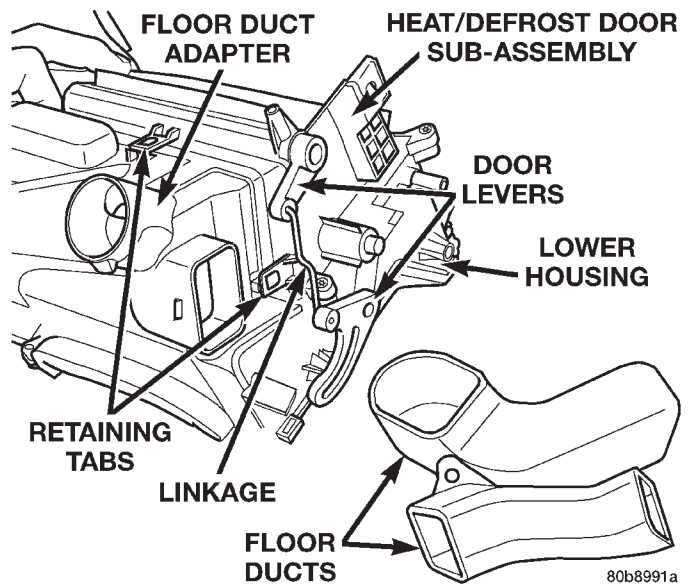

Fig. 42 Floor Ducts (Housing Removed)

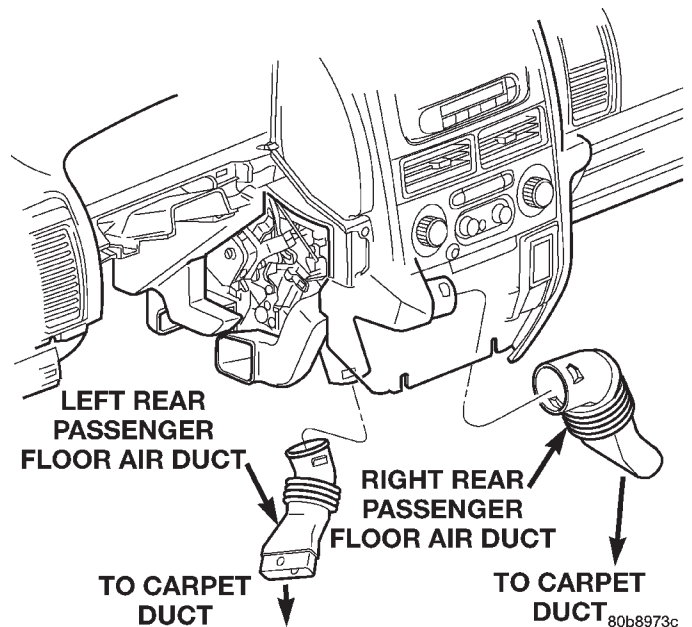

Fig. 43 Rear Floor Ducts

molded into the carpeting, and must be replaced as a unit if damaged.

(3) Reverse the removal procedures to install.

PANEL OUTLETS

The driver side, and passenger side panel outlets are available for service. The center outlets are only serviced as part of the instrument cluster center bezel unit.

(1) Remove the instrument panel top pad from the instrument panel. Refer to Instrument Panel Top Pad

REMOVAL AND INSTALLATION (Continued)

in Group 8E - Instrument Panel Systems for the procedures.

(2) Remove the two screws that secure each outlet to the backside of the instrument panel top pad (Fig. 44).

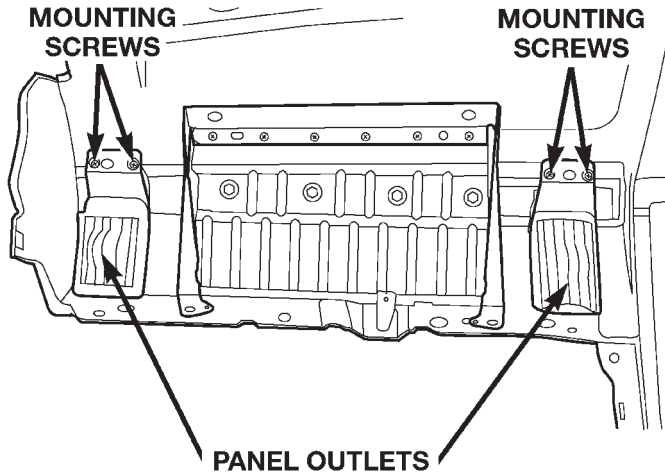

80ba7781

Fig. 44 Panel Outlets (Passenger Side)

(3) Remove the outlet from the top pad.

(4) Reverse the removal procedures to install. Tighten the mounting screws to 2.2 N·m (20 in. lbs.).

EVAPORATOR COIL

WARNING: ON VEHICLES EQUIPPED WITH AIRBAGS, REFER TO GROUP 8M - PASSIVE RESTRAINT SYSTEMS BEFORE ATTEMPTING ANY STEERING WHEEL, STEERING COLUMN, OR INSTRUMENT PANEL COMPONENT DIAGNOSIS OR SERVICE. FAILURE TO TAKE THE PROPER PRECAUTIONS COULD RESULT IN ACCIDENTAL AIRBAG DEPLOYMENT AND POSSIBLE PERSONAL INJURY.

(1) Remove the heater-A/C housing from the vehicle. See Heater-A/C Housing in this group for the procedures.

(2) Place the heater-A/C housing on the work bench.

(3) Remove the defroster duct from the heater-A/C housing.

(4) Remove the defrost door linkage from the top half the housing to enable separation of the two parts.

(5) Remove the screws and clips fastening the upper and lower heater-A/C housing halves.

(6) Remove the top half of the housing.

(7) Lift the evaporator coil unit out of the lower half of the heater-A/C housing (Fig. 45).

(8) Reverse the removal procedures to install. Be certain that the evaporator foam insulator wrap is reinstalled. Be certain that each of the door pivot pins align with the pivot holes in the heater-A/C housing. Tighten the heater-A/C housing screws to 2.2 N·m (20 in. lbs.).

NOTE: If the evaporator is replaced, add 60 milliliters (2 fluid ounces) of refrigerant oil to the refrigerant system.

HEAT/DEFROST DOOR

WARNING: ON VEHICLES EQUIPPED WITH AIRBAGS, REFER TO GROUP 8M - PASSIVE RESTRAINT SYSTEMS BEFORE ATTEMPTING ANY STEERING WHEEL, STEERING COLUMN, OR INSTRUMENT PANEL COMPONENT DIAGNOSIS OR SERVICE. FAILURE TO TAKE THE PROPER PRECAUTIONS COULD RESULT IN ACCIDENTAL AIRBAG DEPLOYMENT AND POSSIBLE PERSONAL INJURY.

REMOVAL

(1) Remove the heater-A/C housing from the vehicle. See Heater-A/C Housing in this group for the procedures.

(2) Place the heater-A/C housing with the tubing side down on a work bench, making allowance for leakage of fluids.

(3) Using a sharp knife, split the foam seal surrounding the panel outlet opening, at the dividing line of the upper and lower cases (Fig. 17).

(4) Place the heater-A/C housing in the upright position on the work bench.

(5) Remove the mode door actuator on the left side of the housing, controlling the mode door in the top of the case (Fig. 18) (Fig. 19).

(6) Remove the screw with plastic washer holding the lever assembly to the upper case section, and move aside (Fig. 20).

(7) Remove the 5 clips that secure the two housing halves to each other. There are 2 on either side at the center, and 1 located at the forward end of the mode door side of the case (Fig. 21).

(8) Release the wire harness electrical connector(s) from the mounts on the lower case at the blower motor end of the unit (Fig. 22).

(9) Remove the 10 screws that secure the two housing halves to each other.

(10) Separate the top half of the heater-A/C housing from the bottom half (Fig. 23).

(11) Remove the evaporator, and styrofoam tray from the lower case.

REMOVAL AND INSTALLATION (Continued)

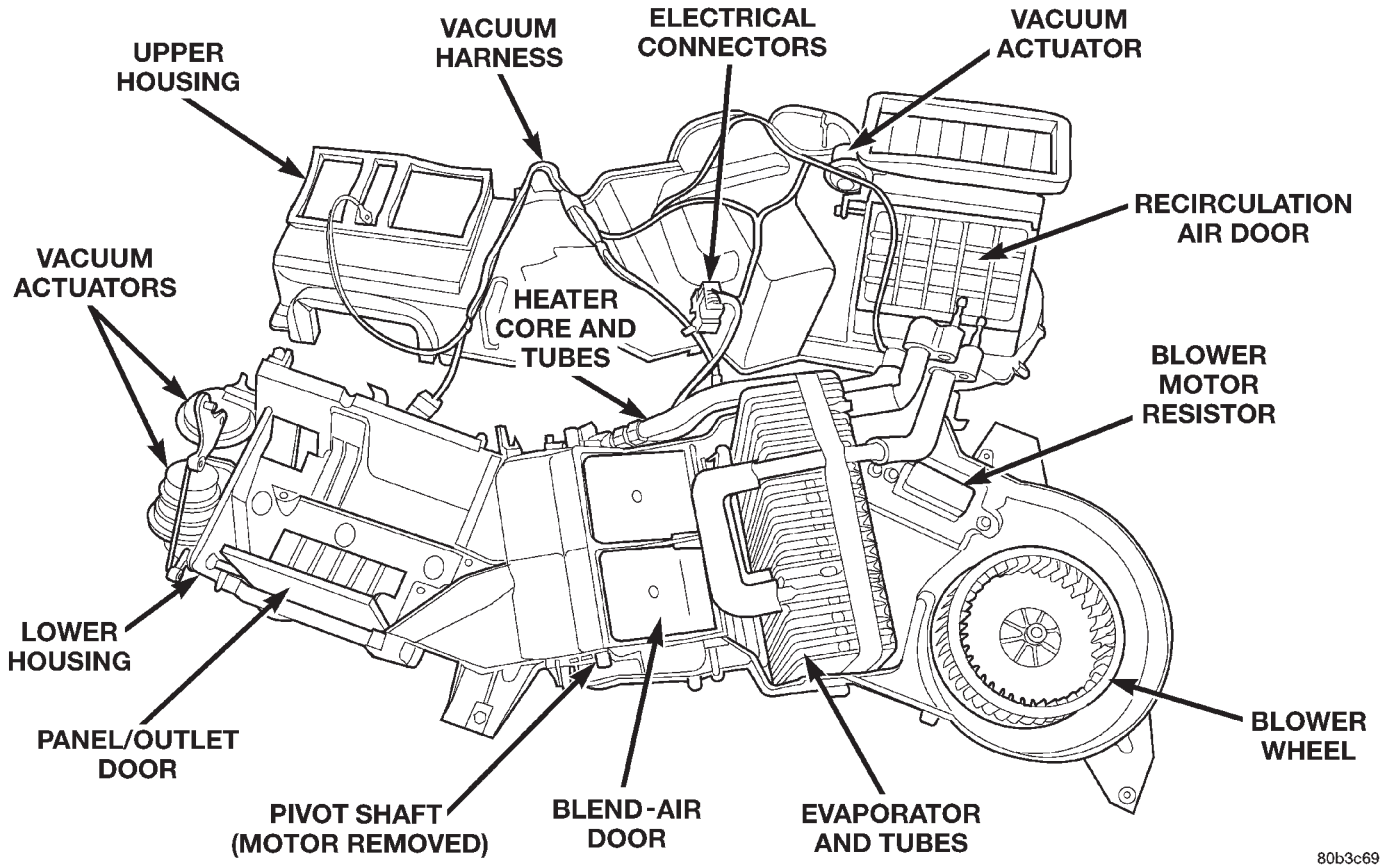

80b3c695

Fig. 45 HVAC Housing and Evaporator

- (12) Place the heater-A/C housing upside down on a work bench.
- (13) Unscrew and remove the 2 floor heat ducts.
- (14) Unsnap and remove the duct adapter from the bottom of the heat/defrost door sub-assembly (Fig. 46).

- (15) Gently pry the metal linkage from the heat/defrost door lever. Remove the heat/defrost door sub-assembly, which is attached to the housing with 4 screws (Fig. 47).

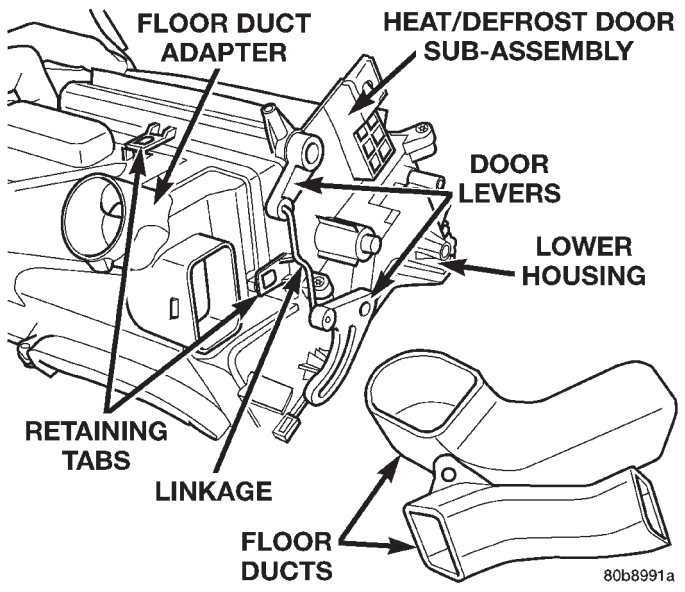

80b8991a

Fig. 46 Heat/Defrost Door Ducts, and Adapter

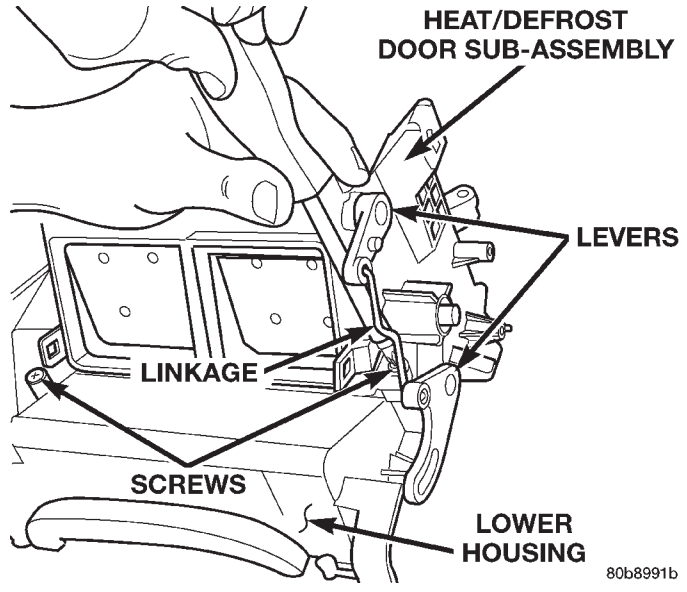

80b8991b

Fig. 47 Heat/Defrost Door Sub-Assembly Removal

- (16) Pinch the retention tabs holding the heat/defrost door pivot shaft lever to the case. The 3 plastic

REMOVAL AND INSTALLATION (Continued)

tabs, located on the inside of the case, are part of the shaft retainer.

(17) Remove the heat/defrost door (Fig. 48).

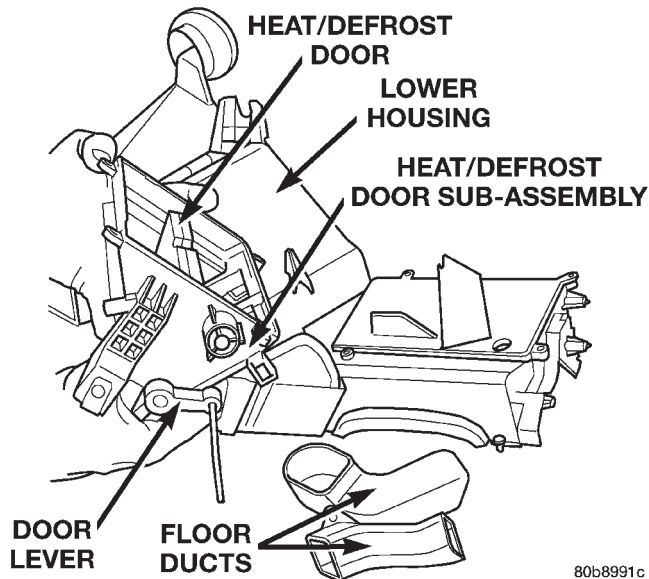

80b8991c

Fig. 48 Heat/Defrost Door Removal

INSTALLATION

(1) Reverse the removal procedures to install.

- Be certain that each of the door pivot pins align with the pivot holes in the heater-A/C housing.
- Tighten the heater-A/C housing screws to 2.2 N·m (20 in. lbs.).
- Check door for binding after replacement, and after assembly of housing.

HEATER-A/C CONTROL

WARNING: ON VEHICLES EQUIPPED WITH AIR-BAGS, REFER TO GROUP 8M - PASSIVE RESTRAINT SYSTEMS BEFORE ATTEMPTING ANY STEERING WHEEL, STEERING COLUMN, OR INSTRUMENT PANEL COMPONENT DIAGNOSIS OR SERVICE. FAILURE TO TAKE THE PROPER PRECAUTIONS COULD RESULT IN ACCIDENTAL AIR-BAG DEPLOYMENT AND POSSIBLE PERSONAL INJURY.

REMOVAL

- (1) Disconnect and isolate the battery negative cable.
- (2) Remove the inboard switch pod bezel from the instrument panel. Refer to Switch Pod Bezel in Group 8E - Instrument Panel Systems for the procedures.
- (3) Remove the 4 screws that secure the heater-A/C control to the instrument panel (Fig. 49).

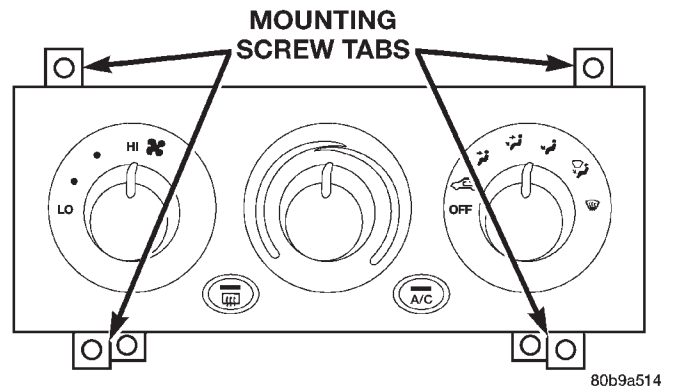

80b9a514

Fig. 49 Heater-A/C Control Remove/Install

(4) Pull the heater-A/C control assembly away from the instrument panel far enough to access the connections on the back of the control.

(5) Unplug the wire and/or vacuum harness connectors from the back of the heater-A/C control (Fig. 50).

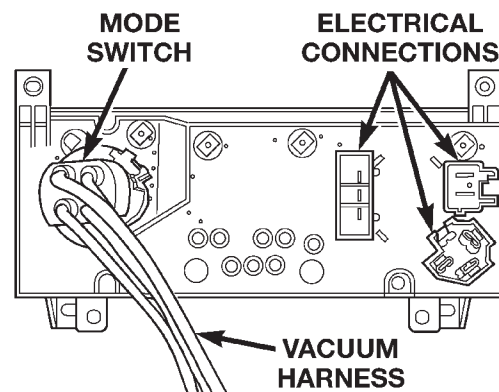

80b9a515

Fig. 50 Heater-A/C Control Connections

(6) Remove the heater-A/C control from the instrument panel.

INSTALLATION

- (1) Plug the wire harness and/or vacuum harness connectors into the back of the heater-A/C control.
- (2) Position the heater-A/C control in the instrument panel and secure it with 4 screws. Tighten the screws to 2.2 N·m (20 in. lbs.).
- (3) Reinstall the inboard switch pod bezel onto the instrument panel. Refer to Switch Pod Bezel in Group 8E - Instrument Panel Systems for the procedures.
- (4) Connect the battery negative cable.

HEATER-A/C HOUSING

The heater-A/C housing assembly must be removed from the vehicle and the two halves of the housing separated for service access of the heater core, evaporator coil, blend-air door(s), and each of the various mode control doors.

REMOVAL AND INSTALLATION (Continued)

WARNING: ON VEHICLES EQUIPPED WITH AIR-BAGS, REFER TO GROUP 8M - PASSIVE RESTRAINT SYSTEMS BEFORE ATTEMPTING ANY STEERING WHEEL, STEERING COLUMN, OR INSTRUMENT PANEL COMPONENT DIAGNOSIS OR SERVICE. FAILURE TO TAKE THE PROPER PRECAUTIONS COULD RESULT IN ACCIDENTAL AIR-BAG DEPLOYMENT AND POSSIBLE PERSONAL INJURY.

REMOVAL

- (1) Disconnect and isolate the battery negative cable.
- (2) Remove the instrument panel from the vehicle. Refer to Instrument Panel Assembly in Group 8E - Instrument Panel Systems for the procedures.
- (3) Recover the refrigerant from the refrigerant system. See Refrigerant Recovery in this group for the procedures.
- (4) Disconnect the liquid line refrigerant line from the evaporator inlet tube. Install plugs in, or tape over all of the opened refrigerant line fittings.
- (5) Disconnect the suction line refrigerant line from the evaporator outlet tube. Install plugs in, or tape over all of the opened refrigerant line fittings.
- (6) Disconnect the heater hoses from the heater core tubes. Clamp off the heater hoses to prevent loss of coolant. Refer to Group 7-Cooling System for the procedures. Install plugs in, or tape over the opened heater core tubes.
- (7) If the vehicle is equipped with the manual temperature control system, unplug the heater-A/C system vacuum supply line connector from the tee fitting near the heater core tubes.

- (8) Remove the coolant reserve/overflow bottle from the passenger side inner fender shield. Refer to Group 7 - Cooling System for the procedures.
- (9) Remove the Powertrain Control Module (PCM) from the passenger side dash panel in the engine compartment and set it aside. Do not unplug the PCM wire harness connectors. Refer to Group 14 - Fuel System for the procedures.

- (10) Remove the nuts from the heater-A/C housing mounting studs on the engine compartment side of the dash panel (Fig. 51).
- (11) Remove the rear floor heat ducts from the floor heat duct outlets (Fig. 52).
- (12) Unplug the heater-A/C housing wire harness connectors.
- (13) Remove the heater-A/C housing mounting nuts from the studs on the passenger compartment side of the dash panel (Fig. 53).
- (14) Remove the heater-A/C housing from the vehicle, ensuring that the interior is covered in case of loss of fluids.

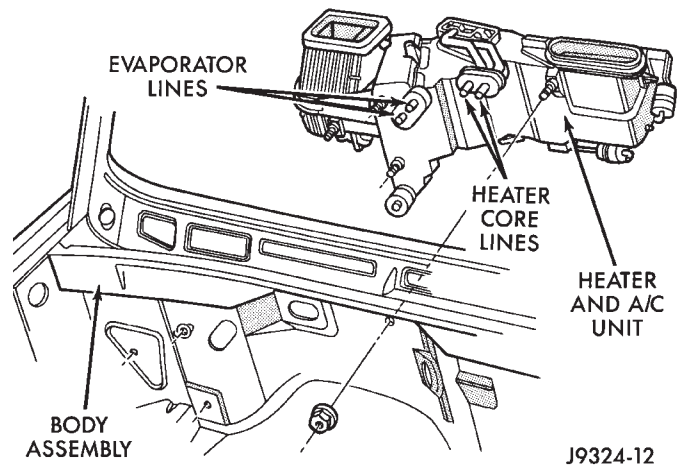

Fig. 51 Heater-A/C Housing Remove/Install

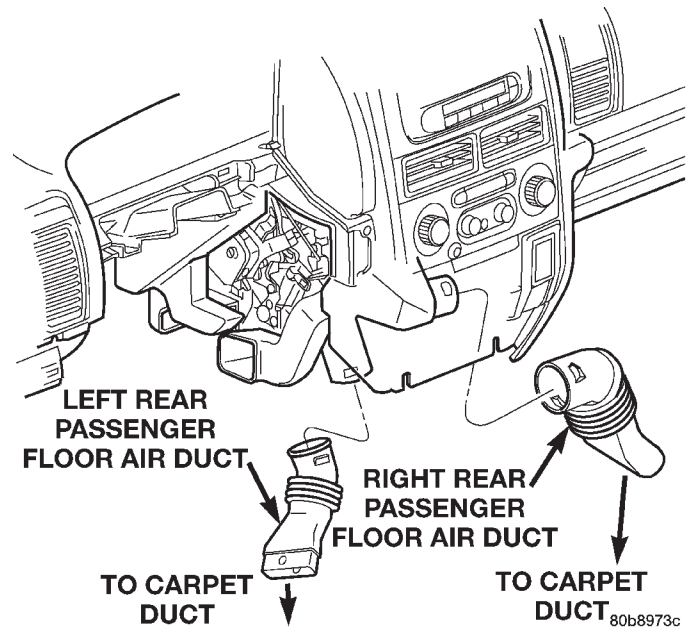

Fig. 52 Rear Floor Heat Ducts

INSTALLATION

- (1) Position the heater-A/C housing to the dash panel. Be certain that the evaporator condensate drain tube and the housing mounting studs are inserted into their correct mounting holes.
- (2) Install the heater-A/C housing mounting nuts to the studs on the passenger compartment side of the dash panel. Tighten the nuts to 4.5 N·m (40 in. lbs.).
- (3) Connect the heater-A/C housing wire harness connectors.
- (4) Reinstall the rear floor heat ducts to the center floor heat duct outlets.
- (5) Install and tighten the nuts onto the heater-A/C housing mounting studs on the engine compart-

REMOVAL AND INSTALLATION (Continued)

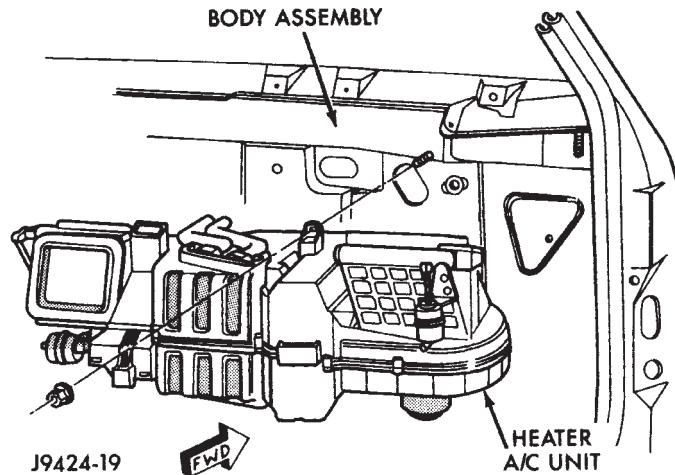

Fig. 53 Heater A/C Housing Remove/Install

ment side of the dash panel. Tighten the nuts to 7 N·m (60 in. lbs.).

(6) Reinstall the PCM to the passenger side dash panel in the engine compartment. Refer to Group 14 - Fuel System for the procedures.

(7) Reinstall the coolant reserve/overflow bottle to the passenger side inner fender shield. Refer to Group 7 - Cooling System for the procedures.

(8) If the vehicle is equipped with the manual temperature control system, connect the heater-A/C system vacuum supply line connector to the tee fitting near the heater core tubes.

(9) Unclamp/unplug the heater core hoses and tubes. Connect the heater hoses to the heater core tubes and fill the engine cooling system. Refer to Group 7-Cooling System for the procedures.

(10) Unplug or remove the tape from the suction line and the evaporator outlet tube fittings. Connect the suction line coupler to the evaporator outlet tube. See Refrigerant Line Coupler in this group for the procedures.

(11) Unplug or remove the tape from the liquid line and the evaporator inlet tube fittings. Connect the liquid line coupler to the evaporator inlet tube. See Refrigerant Line Coupler in this group for the procedures.

(12) Evacuate the refrigerant system. See Refrigerant System Evacuate in this group for the procedures.

(13) Charge the refrigerant system. See Refrigerant System Charge in this group for the procedures.

(14) Install the instrument panel in the vehicle. Refer to Group 8E - Instrument Panel Systems for the procedures.

(15) Connect the battery negative cable.

(16) Start the engine and check for proper operation of the heating and air conditioning systems.

HEATER CORE AND TUBES

WARNING: ON VEHICLES EQUIPPED WITH AIR-BAGS, REFER TO GROUP 8M - PASSIVE RESTRAINT SYSTEMS BEFORE ATTEMPTING ANY STEERING WHEEL, STEERING COLUMN, OR INSTRUMENT PANEL COMPONENT DIAGNOSIS OR SERVICE. FAILURE TO TAKE THE PROPER PRECAUTIONS COULD RESULT IN ACCIDENTAL AIR-BAG DEPLOYMENT AND POSSIBLE PERSONAL INJURY.

REMOVAL

(1) Remove the heater-A/C housing from the vehicle. See Heater-A/C Housing in this group for the procedures.

(2) Remove the foam gasket surrounding the core tubes.

NOTE: Notice the orientation of the irregularly shaped gasket on the tubes. The gasket must be placed correctly to ensure proper sealing against the body during reinstallation.

(3) Remove the screws and retainers that secure the heater core and tubes to the heater-A/C housing (Fig. 54).

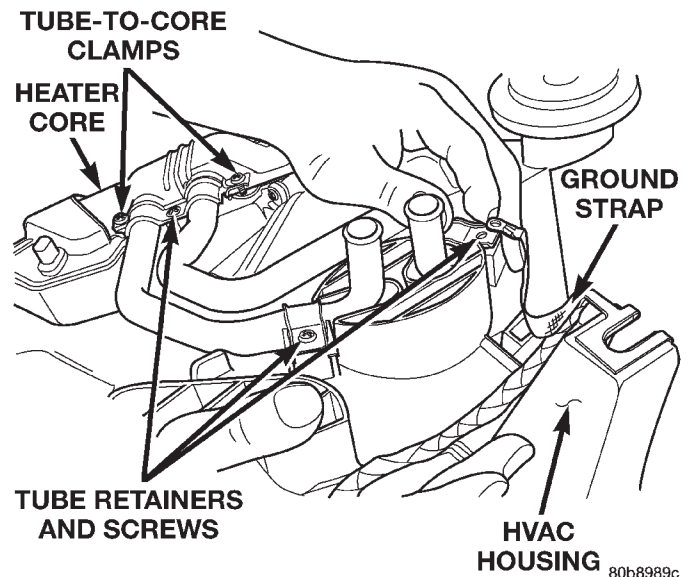

Fig. 54 Heater Core, Tubes, Retainers

(4) Remove the mode door actuator if necessary, for clearance to remove the core.

(5) Lift the heater core straight up and out of the heater-A/C housing (Fig. 55).

(6) When replacing individual tubes, loosen and remove the round tube-to-core clamp, and pull tube from core.

REMOVAL AND INSTALLATION (Continued)

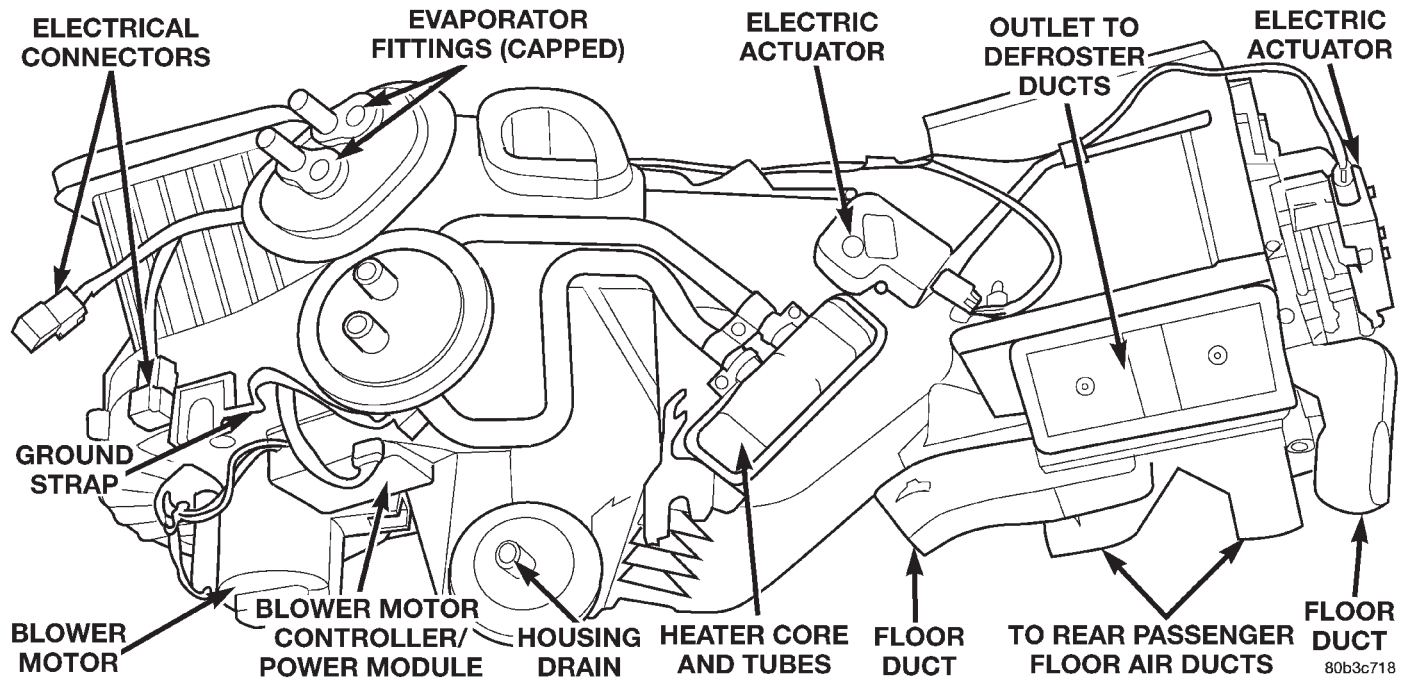

Fig. 55 Heater Core and Tubes

INSTALLATION

(1) When installing individual tubes, insert tube into core ensuring that tube O-ring is seated in core and not pinched. Hold tube in seated position while installing the round tube-to-core clamp (Fig. 56).

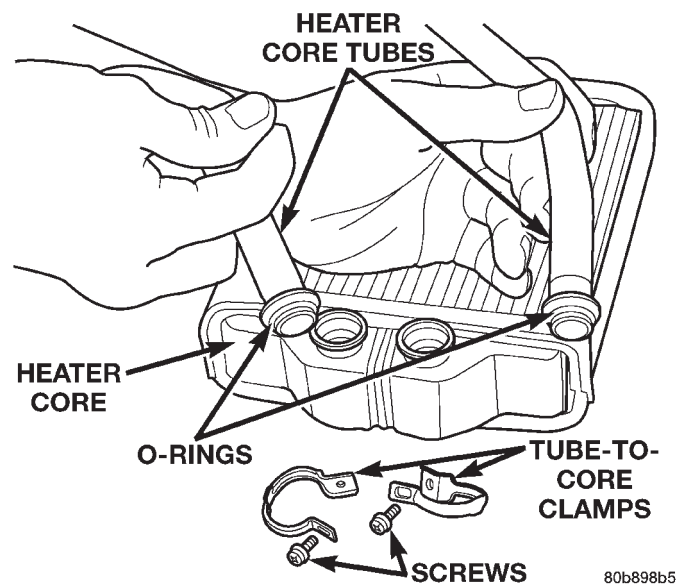

Fig. 56 Heater Core, Tubes, O-rings

NOTE: The round tube-to-heater-core clamp should be left loose enough to turn the tube in the core. Position the core in the housing, and then tighten the tube-to-heater-core clamp after orienting the tubes to the molded heater-A/C housing.

(2) Lower the heater core into the heater-A/C housing.

(3) Install the mode door actuator, if removed from housing for core removal.

(4) Position the retainers over the heater core tubes. Install and tighten the screws that secure the heater core and retainers to the heater-A/C housing. Tighten the screws to 2.2 N-m (20 in. lbs.).

NOTE: The grounding strap is to be attached to the lower heater core tube retainer.

(5) Reinstall the heater-A/C housing to the vehicle. See Heater-A/C Housing in this group for the procedures.

HIGH PRESSURE RELIEF VALVE

WARNING: REVIEW THE WARNINGS AND CAUTIONS IN THE FRONT OF THIS GROUP BEFORE PERFORMING THE FOLLOWING OPERATION.

REMOVAL

(1) Disconnect and isolate the battery negative cable.

(2) Recover the refrigerant from the refrigerant system. See Refrigerant Recovery in this group for the procedures.

(3) Turn the relief valve counterclockwise to remove it from the compressor manifold (Fig. 57). Install a plug in, or tape over the opened relief valve fitting on the compressor manifold.

REMOVAL AND INSTALLATION (Continued)

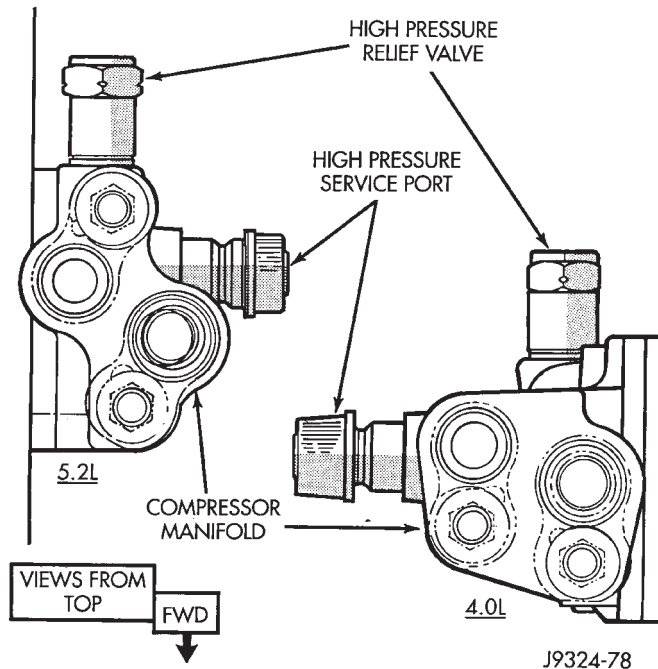

Fig. 57 High Pressure Relief Valve - Typical

INSTALLATION

- (1) Remove the tape or plug from the relief valve fitting on the compressor manifold.
- (2) Install the high pressure relief valve in the compressor manifold fitting.
- (3) Connect the battery negative cable.
- (4) Evacuate the refrigerant system. See Refrigerant System Evacuate in this group for the procedures.
- (5) Charge the refrigerant system. See Refrigerant System Charge in this group for the procedures.

HIGH PRESSURE SWITCH

REMOVAL

- (1) Disconnect and isolate the battery negative cable.
- (2) Unplug the wire harness connector from the high pressure switch, which is mounted to a fitting on the discharge line between the compressor, near the condenser inlet (Fig. 58).
- (3) Unscrew the high pressure switch from the discharge line fitting.
- (4) Remove the high pressure switch from the vehicle.
- (5) Remove the O-ring seal from the discharge line fitting and discard.

INSTALLATION

- (1) Lubricate a new O-ring seal with clean refrigerant oil and install it on the discharge line fitting. Use only the specified O-rings as they are made of a special material for the R-134a system. Use only

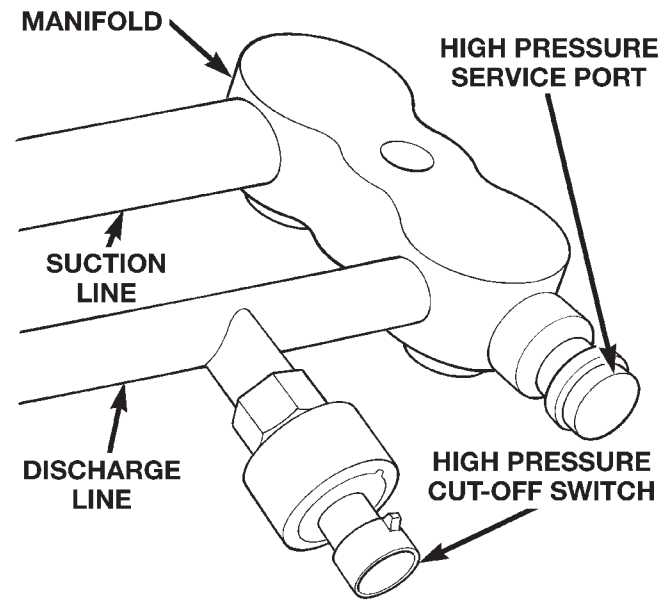

Fig. 58 High Pressure Switch - Typical

refrigerant oil of the type recommended for the compressor in the vehicle.

- (2) Install and tighten the high pressure switch on the discharge line fitting.
- (3) Plug the wire harness connector into the high pressure switch.
- (4) Connect the battery negative cable.

LIQUID LINE

Any kinks or sharp bends in the refrigerant plumbing will reduce the capacity of the entire air conditioning system. Kinks and sharp bends reduce the flow of refrigerant in the system. High pressures are produced in the refrigerant system when the air conditioning compressor is operating. Extreme care must be exercised to make sure that each of the refrigerant system connections is pressure-tight and leak free.

WARNING: REVIEW THE WARNINGS AND CAUTIONS IN THE FRONT OF THIS GROUP BEFORE PERFORMING THE FOLLOWING OPERATION.

REMOVAL

- (1) Disconnect and isolate the battery negative cable.
- (2) Recover the refrigerant from the refrigerant system. See Refrigerant Recovery in this group for the procedures.
- (3) Unsnap the plastic retainer clips that secure the liquid line to the inner fender shield and the dash panel in the engine compartment.

REMOVAL AND INSTALLATION (Continued)

- (4) Disengage the liquid line from the plastic retainer clips.
- (5) Disconnect the liquid line refrigerant line fitting from the evaporator inlet tube. Install plugs in, or tape over all of the opened refrigerant line fittings.
- (6) Disconnect the liquid line from the condenser outlet tube refrigerant line fitting. Install plugs in, or tape over all of the opened refrigerant line fittings.
- (7) Remove the liquid line from the plastic clip that secures it to the right inner fender shield.
- (8) Remove the liquid line from the vehicle.

INSTALLATION

- (1) Remove the tape or plugs from the refrigerant line fittings on the condenser outlet tube and the condenser end of the liquid line.
- (2) Remove the tape or plugs from the refrigerant line fittings on the evaporator end of the liquid line and from the evaporator inlet tube.
- (3) Install the liquid line into the plastic retainer clips that secure it to the inner fender shield and the dash panel and snap the retainer clips closed.
- (4) Connect the battery negative cable.
- (5) Evacuate the refrigerant system. See Refrigerant System Evacuate in this group for the procedures.
- (6) Charge the refrigerant system. See Refrigerant System Charge in this group for the procedures.

LOW PRESSURE CYCLING CLUTCH SWITCH

REMOVAL

- (1) Disconnect and isolate the battery negative cable.
- (2) Unplug the wire harness connector from the low pressure cycling clutch switch on the top of the accumulator.
- (3) Unscrew the low pressure cycling clutch switch from the fitting on the top of the accumulator (Fig. 59).
- (4) Remove the O-ring seal from the accumulator fitting and discard.

INSTALLATION

- (1) Lubricate a new O-ring seal with clean refrigerant oil and install it on the accumulator fitting. Use only the specified O-rings as they are made of a special material for the R-134a system. Use only refrigerant oil of the type recommended for the compressor in the vehicle.
- (2) Install and tighten the low pressure cycling clutch switch on the accumulator fitting. The switch should be hand-tightened onto the accumulator fitting.
- (3) Plug the wire harness connector into the low pressure cycling clutch switch.

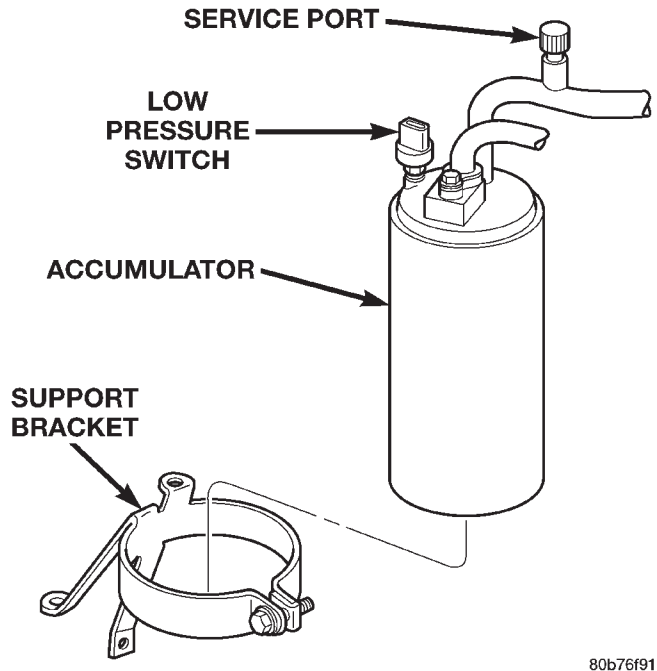

Fig. 59 Accumulator and Support Bracket

- (4) Connect the battery negative cable.

MODE DOOR ACTUATORS

WARNING: ON VEHICLES EQUIPPED WITH AIRBAGS, REFER TO GROUP 8M - PASSIVE RESTRAINT SYSTEMS BEFORE ATTEMPTING ANY STEERING WHEEL, STEERING COLUMN, OR INSTRUMENT PANEL COMPONENT DIAGNOSIS OR SERVICE. FAILURE TO TAKE THE PROPER PRECAUTIONS COULD RESULT IN ACCIDENTAL AIRBAG DEPLOYMENT AND POSSIBLE PERSONAL INJURY.

The mode door actuators for vehicles equipped with the standard equipment manual temperature control system are vacuum controlled. The optional Automatic Zone Control (AZC) system uses electric motors to actuate all mode doors. The temperature/blend-air door for all models is actuated by an electric motor, while the AZC system uses 2 separate motors to allow the driver and passenger to select individual comfort levels. The service procedures for both types of actuators are covered by the following procedures.

HEAT/DEFROST - PANEL/DEFROST DOOR MOTOR

- This motor is used only on models equipped with the optional Automatic Zone Control (AZC) system.
- (1) Disconnect and isolate the battery negative cable.
- (2) Remove the two bolts that secure the center instrument panel support bracket to the left side of the floor panel transmission tunnel.

REMOVAL AND INSTALLATION (Continued)

(3) Remove the two bolts that secure the center instrument panel support bracket to the instrument panel.

(4) Remove the center instrument panel support bracket from the vehicle.

(5) Unplug the wire harness connector from the heat/defrost - panel/defrost door motor (Fig. 60).

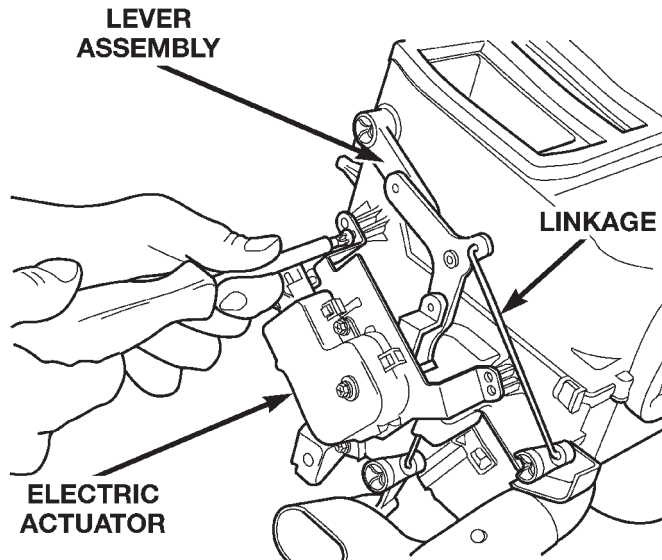

80b897c8

Fig. 60 Heat/Defrost - Panel/Defrost Door Motor

(6) Remove the three screws that secure the heat/defrost-panel/defrost door motor to the heater-A/C housing.

(7) Remove the heat/defrost-panel/defrost door motor from the heater-A/C housing.

(8) Reverse the removal procedures to install. Tighten the mounting screws to 2.2 N·m (20 in. lbs.).

HEAT/DEFROST DOOR VACUUM ACTUATOR

This actuator is used only on models equipped with the standard manual temperature control system.

(1) Remove the heater-A/C housing from the vehicle. See Heater-A/C Housing in this group for the procedures.

(2) Unplug the vacuum harness connector from the heat/defrost door vacuum actuator (Fig. 61).

(3) Disengage the heat/defrost door pivot connection from the heat/defrost door pivot pin.

(4) Remove the screws that secure the heat/defrost door vacuum actuator to the heater-A/C housing.

(5) Remove the heat/defrost door vacuum actuator from the heater-A/C housing.

(6) Reverse the removal procedures to install. Tighten the mounting screws to 2.2 N·m (20 in. lbs.).

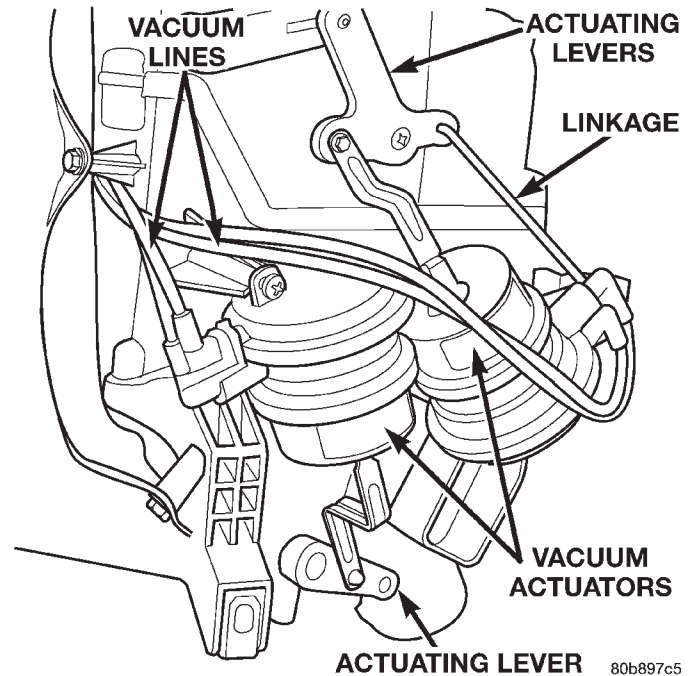

80b897c5

Fig. 61 Heat/Defrost Door Vacuum Actuator

PANEL/DEFROST DOOR VACUUM ACTUATOR

This actuator is used only on models equipped with the standard manual temperature control system.

(1) Remove the heater-A/C housing from the vehicle. See Heater-A/C Housing in this group for the procedures.

(2) Unplug the vacuum harness connector from the heat/defrost door vacuum actuator (Fig. 62).

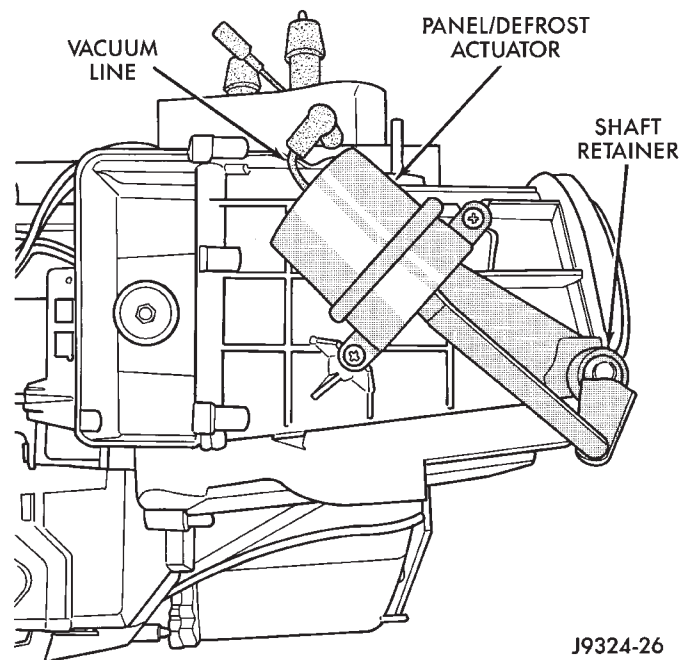

J9324-26

Fig. 62 Panel/Defrost Door Vacuum Actuator

REMOVAL AND INSTALLATION (Continued)

- (3) Disengage the panel/defrost door pivot connection from the panel/defrost door pivot pin.
- (4) Remove the screws that secure the panel/defrost door vacuum actuator to the heater-A/C housing.
- (5) Remove the panel/defrost door vacuum actuator from the heater-A/C housing.
- (6) Reverse the removal procedures to install. Tighten the mounting screws to 2.2 N-m (20 in. lbs.).

RECIRCULATION AIR DOOR MOTOR

- This motor is used only on models equipped with the optional Automatic Zone Control (AZC) system.
- (1) Remove the instrument panel from the vehicle. Refer to Instrument Panel Assembly in Group 8E - Instrument Panel Systems for the procedures.
 - (2) Unplug the wire harness connector from the recirculation air door motor.
 - (3) Remove the 2 screws securing the recirculation air door housing to the HVAC unit (Fig. 63). Tilt the front of the housing up while reaching around the back releasing 2 tangs holding the rear of the housing down.
 - (4) Remove the recirculation air door housing from the HVAC unit.

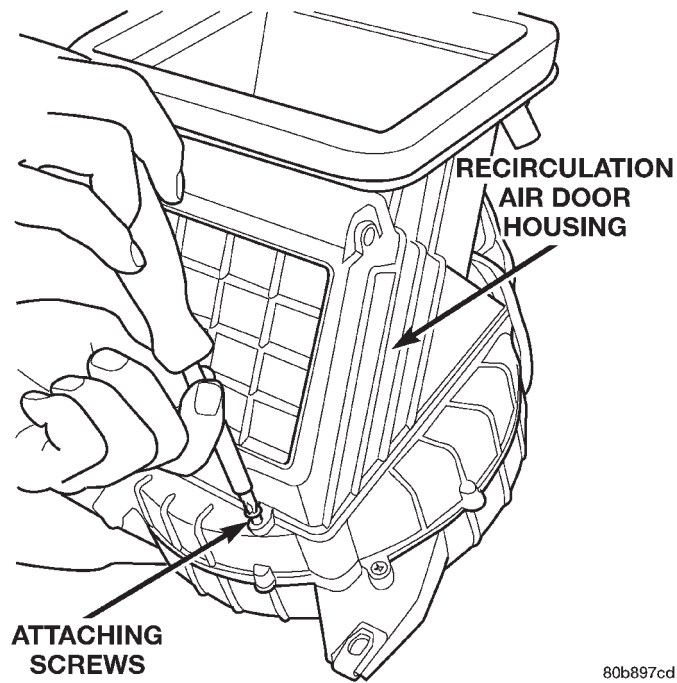

Fig. 63 Recirculation Air Door Housing

- (5) Remove the screws that secure the recirculation air door motor to the heater-A/C housing.
- (6) Remove the recirculation air door motor from the heater-A/C housing.
- (7) Reverse the removal procedures to install. Tighten the mounting screws to 2.2 N-m (20 in. lbs.).

RECIRCULATION AIR DOOR VACUUM ACTUATOR

- This actuator is used only on models equipped with the standard manual temperature control system.
- (1) Remove the instrument panel from the vehicle. Refer to Instrument Panel Assembly in Group 8E - Instrument Panel Systems for the procedures.
 - (2) Unplug the vacuum harness connector from the recirculation air door vacuum actuator.
 - (3) Disengage the recirculation air door pivot connection from the door pivot pin.
 - (4) Disengage the recirculation air door actuating rod from the recirculation air door lever.
 - (5) Remove the screws that secure the recirculation air door vacuum actuator to the heater-A/C housing.
 - (6) Remove the recirculation air door vacuum actuator from the heater-A/C housing.
 - (7) Reverse the removal procedures to install. Tighten the mounting screws to 2.2 N-m (20 in. lbs.).

BLEND-AIR DOOR MOTOR(S)

- The blend-air door motor is used on all models, whether equipped with manual or Automatic Zone Control (AZC). This motor is located on the front of the heater-A/C housing to the right of the floor panel transmission tunnel, and can be removed from the passenger compartment without instrument panel or heater-A/C housing removal.
- (1) Disconnect and isolate the battery negative cable.
 - (2) Remove the glove box door. Remove the lower I/P glove box door surround panel.
 - (3) Unplug the wire harness connector from the temperature/blend-air door motor (Fig. 64).

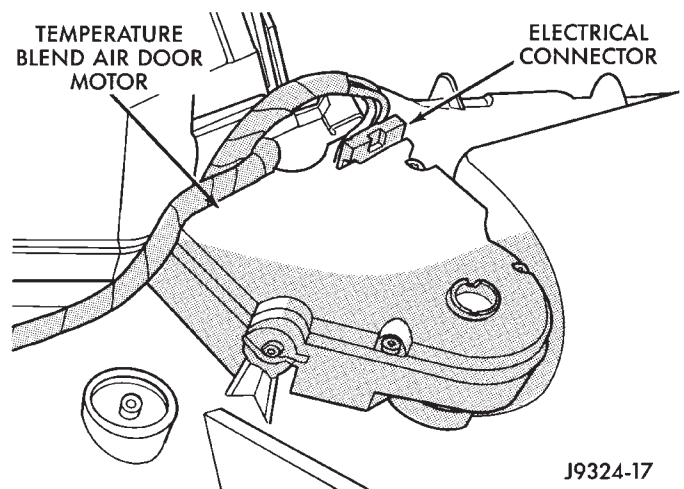

Fig. 64 Blend-Air Door Motor-Typical

- (4) Remove the 2 screws that secure the blend-air door motor to the heater-A/C housing.

REMOVAL AND INSTALLATION (Continued)

(5) Remove the blend-air door motor from the heater-A/C housing.

(6) Reverse the removal procedures to install. Tighten the mounting screws to 2.2 N·m (20 in. lbs.).

PANEL/DEFROST DOOR AND LEVER

WARNING: ON VEHICLES EQUIPPED WITH AIR-BAGS, REFER TO GROUP 8M - PASSIVE RESTRAINT SYSTEMS BEFORE ATTEMPTING ANY STEERING WHEEL, STEERING COLUMN, OR INSTRUMENT PANEL COMPONENT DIAGNOSIS OR SERVICE. FAILURE TO TAKE THE PROPER PRECAUTIONS COULD RESULT IN ACCIDENTAL AIR-BAG DEPLOYMENT AND POSSIBLE PERSONAL INJURY.

REMOVAL

(1) Remove the heater-A/C housing from the vehicle. See Heater-A/C Housing in this group for the procedures.

(2) Place the heater-A/C housing with the tubing side down on a work bench, making allowance for leakage of fluids.

(3) Using a sharp knife, split the foam seal surrounding the panel outlet opening, at the dividing line of the upper and lower cases (Fig. 17).

(4) Place the heater-A/C housing in the upright position on the work bench.

(5) Remove the mode door actuator on the left side of the housing, controlling the mode door in the top of the case (Fig. 18) (Fig. 19).

(6) Remove the screw with plastic washer holding the lever assembly to the upper case section, and move aside (Fig. 20).

(7) Remove the 5 clips that secure the two housing halves to each other. There are 2 on either side at the center, and 1 located at the forward end of the mode door side of the case (Fig. 21).

(8) Release the wire harness electrical connector(s) from the mounts on the lower case at the blower motor end of the unit (Fig. 22).

(9) Remove the 10 screws that secure the two housing halves to each other.

(10) Separate the top half of the heater-A/C housing from the bottom half (Fig. 23).

(11) Pinch the retention tabs holding the panel/defrost door pivot shaft to the case. The 3 plastic tabs, located on the inside of the case, are part of the shaft retainer (Fig. 65).

(12) Using a trim stick or another suitable wide flat-bladed tool, gently pry the panel/defrost door pivot shaft retainer from the pivot shaft.

(13) Remove the panel/defrost door from the heater-A/C housing.

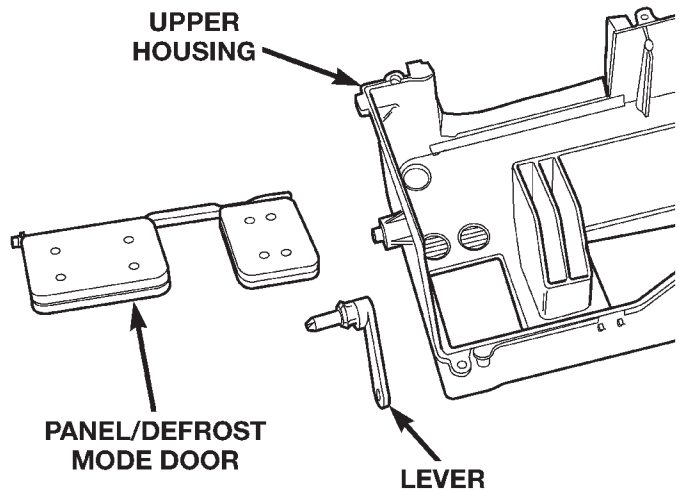

80b9a490

Fig. 65 Panel/Defrost Door

INSTALLATION

Reverse the removal procedures to install.

- Be certain that each of the door pivot pins align with the pivot holes in the heater-A/C housing.
- Tighten the heater-A/C housing screws to 2.2 N·m (20 in. lbs.).
- Check door for binding after replacement, and after assembly of housing.

PANEL OUTLET DOOR

WARNING: ON VEHICLES EQUIPPED WITH AIR-BAGS, REFER TO GROUP 8M - PASSIVE RESTRAINT SYSTEMS BEFORE ATTEMPTING ANY STEERING WHEEL, STEERING COLUMN, OR INSTRUMENT PANEL COMPONENT DIAGNOSIS OR SERVICE. FAILURE TO TAKE THE PROPER PRECAUTIONS COULD RESULT IN ACCIDENTAL AIR-BAG DEPLOYMENT AND POSSIBLE PERSONAL INJURY.

REMOVAL

(1) Remove the heater-A/C housing from the vehicle. See Heater-A/C Housing in this group for the procedures.

(2) Place the heater-A/C housing with the tubing side down on a work bench, making allowance for leakage of fluids.

(3) Using a sharp knife, split the foam seal surrounding the panel outlet opening, at the dividing line of the upper and lower cases (Fig. 17).

(4) Place the heater-A/C housing in the upright position on the work bench.

REMOVAL AND INSTALLATION (Continued)

(5) Remove the mode door actuator on the left side of the housing, controlling the mode door in the top of the case (Fig. 18) (Fig. 19).

(6) Remove the screw with plastic washer holding the lever assembly to the upper case section, and move aside (Fig. 20).

(7) Remove the 5 clips that secure the two housing halves to each other. There are 2 on either side at the center, and 1 located at the forward end of the mode door side of the case (Fig. 21).

(8) Release the wire harness electrical connector(s) from the mounts on the lower case at the blower motor end of the unit (Fig. 22).

(9) Remove the 10 screws that secure the two housing halves to each other.

(10) Separate the top half of the heater-A/C housing from the bottom half (Fig. 23).

(11) Pinch the retention tabs holding the panel outlet door pivot shaft to the case. The 3 plastic tabs, located on the inside of the case, are part of the shaft retainer (Fig. 66).

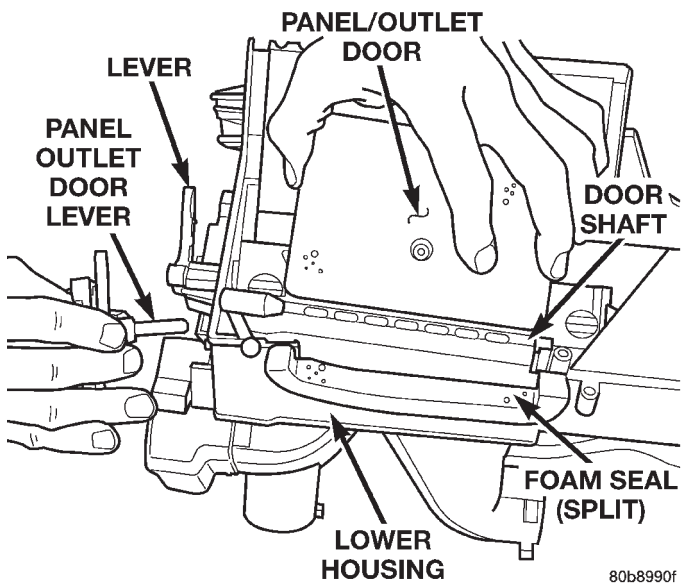

Fig. 66 Panel Outlet Door

(12) Using a trim stick or another suitable wide flat-bladed tool, gently pry the panel outlet door pivot shaft retainer from the pivot shaft.

(13) Remove the panel outlet door from the heater-A/C housing.

INSTALLATION

Reverse the removal procedures to install.

- Be certain that each of the door pivot pins align with the pivot holes in the heater-A/C housing.
- Tighten the heater-A/C housing screws to 2.2 N·m (20 in. lbs.).
- Check door for binding after replacement, and after assembly of housing.

RECIRCULATION AIR DOOR

WARNING: ON VEHICLES EQUIPPED WITH AIR-BAGS, REFER TO GROUP 8M - PASSIVE RESTRAINT SYSTEMS BEFORE ATTEMPTING ANY STEERING WHEEL, STEERING COLUMN, OR INSTRUMENT PANEL COMPONENT DIAGNOSIS OR SERVICE. FAILURE TO TAKE THE PROPER PRECAUTIONS COULD RESULT IN ACCIDENTAL AIR-BAG DEPLOYMENT AND POSSIBLE PERSONAL INJURY.

REMOVAL

(1) Remove the heater-A/C housing from the vehicle. See Heater-A/C Housing in this group for the procedures.

(2) Place the heater-A/C housing right side up on the work bench.

(3) Unplug the wire/vacuum connector from the recirculation air door actuator.

(4) Remove the 2 screws fastening the recirculation air door sub-assembly to the main housing (Fig. 67).

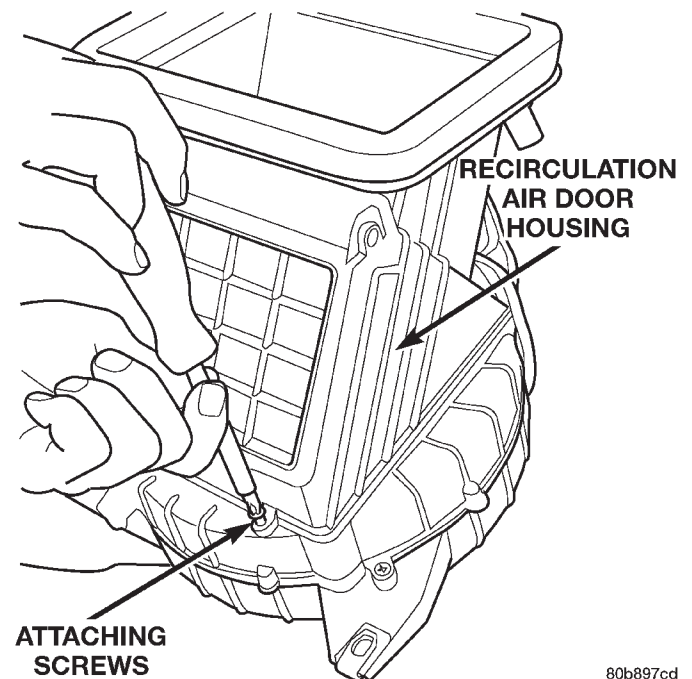

Fig. 67 Recirculation Air Door Housing

(5) Raise the front of the door sub-assembly while releasing the 2 tabs holding the rear to the main housing, and remove the recirculation air door housing.

(6) Remove the electric/vacuum actuator from the recirculation air door sub-assembly and set aside.

(7) Pinch the retention tabs holding the recirculation air door pivot shaft to the case. The 3 plastic

REMOVAL AND INSTALLATION (Continued)

tabs, located on the inside of the case, are part of the shaft retainer.

(8) Remove the recirculation air door from the recirculation air door housing.

INSTALLATION

Reverse the removal procedures to install.

- Be certain that each of the door pivot pins align with the pivot holes in the heater-A/C housing.
- Tighten the heater-A/C housing screws to 2.2 N·m (20 in. lbs.).
- Check door for binding after replacement, and after assembly of housing.

VACUUM CHECK VALVE

(1) Unplug the heater-A/C vacuum supply line connector at the vacuum check valve near the engine intake manifold vacuum adapter fitting.

(2) Note the orientation of the check valve in the vacuum supply line for correct installation.

(3) Unplug the vacuum check valve from the vacuum supply line fittings.

(4) Reverse the removal procedures to install.

VACUUM RESERVOIR

The vacuum reservoir is mounted in the right front of the vehicle behind the headlamp mounting module. The headlamp mounting module and headlamp assembly must be removed from the vehicle to access the vacuum reservoir for service. Refer to Group 8L - Lamps for more information on component removal (Fig. 68).

(1) Remove the two screws that secure the vacuum reservoir to the base of the radiator closure panel.

(2) Remove the vacuum reservoir.

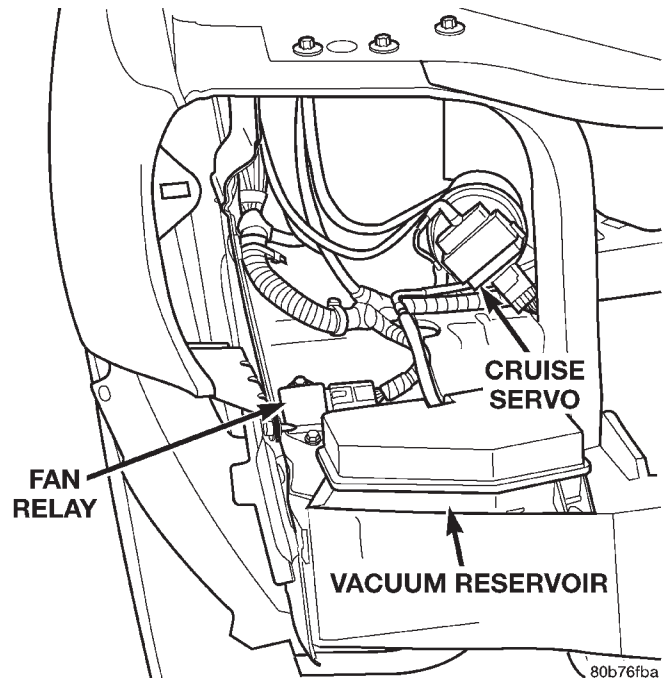

Fig. 68 Vacuum Reservoir

(3) Reverse the removal procedures to install. Tighten the mounting screws to 3.4 N·m (30 in. lbs.).

VARIABLE ORIFICE VALVE

The Variable Orifice Valve (VOV) is located in the liquid line near the condenser. If the orifice valve is faulty or plugged, the liquid line unit must be replaced. See Liquid Line in this group for the service procedures.