

# INSTRUMENT PANEL SYSTEMS

## CONTENTS

	page		page
<b>DESCRIPTION AND OPERATION</b>			
BODY CONTROL MODULE .....	5	INSTRUMENT PANEL CENTER UPPER	
CIGAR LIGHTER RELAY .....	6	BEZEL .....	19
INSTRUMENT CLUSTER .....	3	INSTRUMENT PANEL CIGAR LIGHTER AND	
INSTRUMENT PANEL .....	2	POWER OUTLET .....	21
INSTRUMENT PANEL CIGAR LIGHTER .....	5	INSTRUMENT PANEL DRIVER SIDE BEZEL ...	13
INSTRUMENT PANEL POWER OUTLET .....	6	INSTRUMENT PANEL DRIVER SIDE	
INSTRUMENT PANEL SYSTEM .....	1	COURTESY LAMP BRACKET .....	12
<b>DIAGNOSIS AND TESTING</b>			
BODY CONTROL MODULE .....	9	INSTRUMENT PANEL END CAP .....	25
CIGAR LIGHTER RELAY .....	9	INSTRUMENT PANEL FUSE COVER .....	11
INSTRUMENT CLUSTER .....	7	INSTRUMENT PANEL INTERMEDIATE	
INSTRUMENT PANEL CIGAR LIGHTER .....	9	BRACKET .....	40
INSTRUMENT PANEL POWER OUTLET .....	10	INSTRUMENT PANEL LOWER RIGHT CENTER	
<b>REMOVAL AND INSTALLATION</b>			
BODY CONTROL MODULE .....	12	BEZEL .....	26
CIGAR LIGHTER RELAY .....	21	INSTRUMENT PANEL PASSENGER SIDE	
CLUSTER BEZEL .....	13	BEZEL .....	32
GLOVE BOX .....	23	INSTRUMENT PANEL PLENUM BRACKET ...	40
GLOVE BOX LAMP AND SWITCH .....	27	INSTRUMENT PANEL POWER OUTLET	
GLOVE BOX LATCH .....	25	DOOR .....	22
GLOVE BOX LATCH STRIKER .....	26	INSTRUMENT PANEL STEERING COLUMN	
INSTRUMENT CLUSTER .....	15	BRACKET .....	15
INSTRUMENT CLUSTER COMPONENTS .....	16	INSTRUMENT PANEL STEERING COLUMN	
INSTRUMENT PANEL ASSEMBLY .....	32	SUPPORT BRACKET .....	41
INSTRUMENT PANEL C-CHANNEL COVER		INSTRUMENT PANEL STRUCTURAL DUCT ...	42
BRACKET .....	39	INSTRUMENT PANEL TO CENTER FLOOR	
INSTRUMENT PANEL CENTER LOWER		TUNNEL BRACKET .....	23
BEZEL .....	20	INSTRUMENT PANEL TOP COVER .....	28
		INSTRUMENT PANEL TOP PAD .....	29
		STEERING COLUMN OPENING COVER .....	14

## DESCRIPTION AND OPERATION

### INSTRUMENT PANEL SYSTEM

#### DESCRIPTION

The instrument panel serves as the command center of the vehicle, which necessarily makes it a very complex unit. The instrument panel is designed to house the controls and monitors for standard and optional powertrains, climate control systems, audio systems, lighting systems, safety systems and many other comfort or convenience items. The instrument panel is also designed so that all of the various controls can be safely reached and the monitors can be

easily viewed by the vehicle operator when driving, while still allowing relative ease of access to each of these items for service. See the owner's manual in the vehicle glove box for more information on the features, use and operation of all of the instrument panel components and systems.

This group is responsible for covering service information for the vehicle instrument panel systems. However, complete service information coverage for all of the systems and components housed in the instrument panel in a single section of the service manual would not be practical. Therefore, the service information for any component will be found in the group designated to cover the vehicle system that the

## DESCRIPTION AND OPERATION (Continued)

component belongs to, even though the component is mounted on or in the instrument panel. If you cannot locate a listing for the component or system you are servicing in the table of contents for this group, or if you are uncertain as to which vehicle system a component belongs to, it is suggested that you refer to the alphabetical **Component and System Index** found at the back of this service manual.

## INSTRUMENT PANEL

### DESCRIPTION

Structural support for the instrument panel in this vehicle is accomplished through the use of a molded plastic structural panel and demister air flow duct assembly. The front and rear halves of this structural duct are molded from a blend of polycarbonate and ABS plastics, which gives these components excellent strength and impact resistance. The two halves of this structural duct are vibration welded together.

The structural duct provides integral mounting surfaces for the instrument cluster and other instrument panel-mounted equipment such as the passenger side airbag module, the radio, the heater and air conditioner controls, the glove compartment latch strikers and hinges, the instrument panel steering column support bracket, and the junction block. The structural duct also features integral vacuum and electrical harness routing troughs. All of these integral features help to reduce the total component part requirements, which reduces assembly complexity and potential buzzes, squeaks and rattles. At the same time, these features make the structural duct-based instrument panel more suitable for recycling by minimizing the number of parts to be removed.

A patented feature of the construction of this instrument panel has the heater and air conditioner housing unit and the steering column secured to the structural duct and installed into the vehicle as a unit during vehicle assembly. This feature helps to improve vehicle quality by allowing the instrument panel, heater and air conditioner housing unit and the steering column to be assembled and tested outside the vehicle prior to installation, which is easier and more reliable than in-car assembly and testing. This feature also adds a floor panel mounting point to the instrument panel unit, which provides additional stiffness and system integrity.

A foam-padded cast vinyl instrument panel top pad covers the instrument panel structural duct. This surface is designed to deform upon impact without breaking, while also providing a luxurious feel. The top pad features a grained outer surface and two shallow molded depressions on the top, which can serve as trays to store various small objects. A unique anti-skid texture molded into the top pad sur-

face in the bottom of these depressions will help to prevent objects from shifting in the trays while the vehicle is being driven. The top pad conceals an integral top-hinged steel passenger side airbag door, which is located between the two panel duct air outlets above the glove box. The top pad also features a raised hood formation over the instrument cluster area, which helps to block light reflections from the windshield onto the cluster lens in the daytime, and light reflections from the cluster onto the windshield at night.

The center stack area of the instrument panel features two snap-on bezels. The upper bezel has two integral center panel duct air outlets and conceals the radio and upper heater and air conditioner control mounting hardware. The lower bezel conceals the lower heater and air conditioner control mounting hardware and includes a concealed integral storage bin, which features a push-push latching mechanism and viscous-damped hinges. Pushing in on the face of the bin releases the latch and the bin opens by itself. The lower bezel also houses the two switches for the optional heated driver and passenger front seats, as well as two accessory power outlets. The accessory power outlet to the passenger side of the storage bin is covered by a pivoting door when not in use. The accessory power outlet to the driver side of the storage bin is covered by a snap-in plastic cap when not in use. If the optional smoker's package is ordered, a removable ash receiver is inserted in the storage bin and a cigar lighter is inserted in the driver side accessory power outlet.

The hinged bin-type glove box in the passenger side of the instrument panel features a recessed paddle-operated latch handle that is offset towards the driver side of the vehicle for easier access. The glove box latching mechanism features two bolt-type latches that engage a striker located on each side of the glove box opening for increased strength and integrity. Three molded hook formations on the lower edge of the glove box door are engaged with and pivot on three hinge pins integral to the lower edge of the structural duct. The glove box door also serves as the passenger side knee blocker. A honeycomb structure between the inner and outer glove box door panels helps to absorb the impact load and distribute it to the instrument panel structural duct.

The steering column opening cover serves as the driver side knee blocker. This molded plastic cover has an integral ribbed plastic liner concealed behind it, for increased strength and integrity. The steering column opening cover transfers impact loads through a stamped and welded instrument panel steering column bracket to the cast magnesium instrument panel steering column support bracket, which is

## DESCRIPTION AND OPERATION (Continued)

secured to and distributes the impact load to the instrument panel structural duct.

Modular instrument panel construction allows all of the gauges and controls to be serviced from the front of the instrument panel. In addition, most of the instrument panel electrical or heating and air conditioning components can be accessed without complete instrument panel removal. However, if necessary, the instrument panel unit can be removed from the vehicle as an assembly.

## INSTRUMENT CLUSTER

### DESCRIPTION

A single instrument cluster is offered on this model. This cluster is an Electro-Mechanical Instrument Cluster (EMIC) module that utilizes integrated circuitry and information carried on the Programmable Communications Interface (PCI) data bus network for control of all gauges and many of the indicator lamps. This cluster also incorporates a digital Vacuum Fluorescent Display (VFD) for the odometer/trip odometer display functions. Some variations of this cluster exist due to optional equipment and regulatory requirements.

This instrument cluster includes the following gauges:

- Coolant temperature gauge
- Fuel gauge
- Odometer and trip odometer
- Oil pressure gauge
- Speedometer
- Tachometer
- Voltmeter.

This cluster also includes provisions for the following indicator lamps:

- Airbag indicator lamp
- Anti-lock brake system lamp
- Brake warning lamp
- Check gauges lamp
- Cruise-on indicator lamp
- Fog lamps-on indicator lamp
- Headlamp high beam indicator lamp
- Low fuel warning lamp
- Malfunction indicator (Check Engine) lamp
- Overdrive-off indicator lamp
- Part-time four-wheel drive indicator lamp (Selectrac)
- Seat belt reminder lamp
- Sentry Key Immobilizer System (SKIS) indicator lamp
- Transmission oil temperature warning lamp
- Turn signal indicator lamps.

This instrument cluster features circuitry that has a self-diagnostic actuator test capability, which will test each of the PCI data bus message-controlled

functions of the cluster by lighting the appropriate indicator lamps (except for the airbag indicator lamp), sweeping the gauge needles from their respective minimum to their maximum readings, and stepping the odometer display sequentially from all zeros through all nines. See the proper Diagnostic Procedures manual for more information on this function.

The instrument cluster circuitry also sends chime tone requests over the PCI data bus to the Body Control Module (BCM) when it monitors certain conditions or inputs. The BCM replaces the chime or buzzer module. Refer to **Chime Warning System** in the Description and Operation section of Group 8U - Chime/Buzzer Warning Systems for more information on this feature.

This vehicle also offers several customer programmable features, which allows the selection of several optional electronic features to suit individual preferences. Refer to **ELECTRONIC VEHICLE INFORMATION CENTER PROGRAMMING** in the Service Procedures section of Group 8V - Overhead Console Systems for more information on the customer programmable feature options. Customer programmable feature options affecting the EMIC module include:

- **Low Fuel Chime** - Allows the option of having a single chime sound as an audible alert whenever the instrument cluster low fuel warning lamp lights, or having no audible alert.

The instrument cluster component parts for this model are available for service. The cluster lens, hood and mask unit, the major gauges and the minor gauge sets, the trip odometer reset knob, the cluster housing with electronic circuit board and rear housing cover, and the incandescent lamp bulbs and bulb holders are available for service replacement.

### OPERATION

All of the gauges and many of the indicator lamps in this instrument cluster are controlled by a microprocessor that is located on the instrument cluster electronic circuit board. The instrument cluster microprocessor uses internal programming, messages received over the Programmable Communications Interface (PCI) data bus network, and a few hard wired inputs to perform its many gauge and indicator lamp control functions. The PCI data bus network allows the sharing of sensor information. This practice helps to reduce wire harness complexity, internal controller hardware and component sensor current loads.

The instrument cluster microprocessor smooths the input data using algorithms to provide gauge readings that are accurate, stable and responsive to operating conditions. These algorithms are designed to provide gauge readings during normal operation that

## DESCRIPTION AND OPERATION (Continued)

are consistent with customer expectations. However, when abnormal conditions exist, such as low or high battery voltage, low oil pressure or high coolant temperature, the algorithm drives the gauge pointer to an extreme position and the microprocessor turns on the Check Gauges indicator lamp to provide a distinct visual indication of a problem to the vehicle operator. The instrument cluster circuitry also sends chime tone requests over the PCI data bus to the Body Control Module (BCM) when it monitors certain conditions or inputs to provide the vehicle operator with an audible alert.

This instrument cluster also features a six-digit vacuum-fluorescent odometer and trip odometer display, which is integral to the cluster electronic circuit board. This display is toggled between the odometer and trip odometer functions by a push button on the face of the cluster. Pressing and holding the button depressed when the trip odometer reading is displayed will reset the trip odometer reading to zero. The instrument cluster microprocessor remembers which function was active when the ignition switch is turned to the off position, and returns the display to that function when the ignition is turned on again.

**GAUGE**

With the ignition switch in the On or Start positions, voltage is supplied to all gauges through the instrument cluster electronic circuit board. With the ignition switch in the Off position, voltage is not supplied to the gauges. The gauges do not accurately indicate any vehicle condition unless the ignition switch is in the On or Start positions.

All of the instrument cluster gauges, except the odometer and trip odometer, are air core magnetic units. Two fixed electromagnetic coils are located within the gauge. These coils are wrapped at right angles to each other around a movable permanent magnet. The movable magnet is suspended within the coils on one end of a shaft. The gauge needle is attached to the other end of the shaft.

One of the coils has a fixed current flowing through it to maintain a constant magnetic field strength. Current flow through the second coil changes, which causes changes in its magnetic field strength. The current flowing through the second coil is changed by the instrument cluster electronic circuitry in response to messages received on the Programmable Communications Interface (PCI) data bus network.

The gauge needle moves as the movable permanent magnet aligns itself to the changing magnetic fields created around it by the electromagnets. The instrument cluster circuitry is programmed to move all of the gauge needles back to the low end of their respec-

tive scales after the ignition switch is turned to the Off position.

**INDICATOR LAMP**

Indicator lamps are located in the instrument cluster and are served by the cluster circuit board and connectors. Many of the indicator lamps in the instrument cluster are controlled by the instrument cluster circuitry in response to messages received over the Programmable Communications Interface (PCI) data bus network.

The part-time four-wheel drive indicator lamp and turn signal indicator lamps are hard wired. The seat belt reminder lamp is controlled by the instrument cluster programming. The brake warning lamp is controlled by a hard wired input from the park brake switch and by PCI data bus messages from the Controller Anti-lock Brake (CAB). The instrument cluster circuitry uses PCI data bus messages from the Powertrain Control Module (PCM), Airbag Control Module (ACM), Body Control Module (BCM) and CAB to control all of the remaining indicator lamps.

The indicator lamps in the instrument cluster use incandescent bulbs and holders. Each incandescent indicator lamp has a replaceable bulb and bulb holder.

**CLUSTER ILLUMINATION LAMP**

The instrument cluster features incandescent illumination lamp bulbs. The illumination intensity of these bulbs and of the vacuum-fluorescent electronic display are controlled by the instrument cluster microprocessor based upon dimming messages received from the Body Control Module (BCM) over the Programmable Communications Interface (PCI) data bus. The BCM uses inputs from the headlamp and panel dimmer switches on the left (lighting) multi-function switch control stalk and internal programming to decide what dimming message is required. The BCM then sends the proper dimming messages to the instrument cluster over the PCI data bus.

The BCM also sends the proper panel lamps dimming level messages over the PCI data bus to control the dimming levels of the various vacuum fluorescent displays. All modules on the PCI data bus with vacuum fluorescent displays (instrument cluster, radio, electronic vehicle information center) receive these messages and adjust their dimming levels to match that of the incandescent cluster illumination bulbs located in the instrument cluster.

Vehicles equipped with the Auto Headlamps option have an automatic parade mode. In this mode, the BCM uses an input from the auto headlamp light sensor to determine the ambient light levels. If the BCM decides that the exterior lighting is turned on

## DESCRIPTION AND OPERATION (Continued)

in the daylight, it overrides the selected panel dimmer switch signal by sending a message over the PCI data bus to illuminate all vacuum fluorescent displays at full brightness for easier visibility in daytime light levels. The automatic parade mode has no effect on the incandescent bulb dimming levels.

Each of the cluster illumination lamps is located on the instrument cluster circuit board. Each cluster illumination lamp has a replaceable bulb and bulb holder.

## BODY CONTROL MODULE

### DESCRIPTION

A Body Control Module (BCM) is used on this model to control and integrate many of the electronic features and functions of the vehicle. The BCM is concealed below the driver side end of the instrument panel in the passenger compartment, where it is mounted to the dash panel side of the junction block with four screws. The BCM has two external connector receptacles that receive connections from the instrument panel wire harness. The BCM also has a connector concealed on the back side of the unit that joins it directly to the circuitry within the junction block.

The BCM contains a central processing unit and interfaces with other electronic modules in the vehicle on the Programmable Communications Interface (PCI) data bus network. The PCI data bus network allows the sharing of sensor information. This helps to reduce wire harness complexity, reduce internal controller hardware, and reduce component sensor current loads. At the same time, this system provides increased reliability, enhanced diagnostics, and allows the addition of many new feature capabilities.

Some of the functions and features that the BCM supports or controls, include:

- Chimes
- Automatic headlamp control
- Headlamp delay
- Headlamps on with ignition off and driver door open warning
  - Key in ignition with ignition off and driver door open warning
  - Automatic funeral or parade mode
  - Panel lamp dimming
  - Vehicle Theft Security System (VTSS)
  - Illuminated entry
  - Heated rear window and heated outside mirror control
    - Intermittent wipe control
    - Monitoring and transmitting rear door, liftgate, and liftgate flip-up glass ajar data
    - Monitoring and transmitting outside ambient temperature data

- Monitoring and transmitting air conditioning select switch data
- Courtesy lamp time-out
- Door lock inhibit
- Electronic odometer and trip odometer
- Brake warning lamp
- Check gauges lamp
- High beam indicator lamp
- Seatbelt reminder lamp and chime
- Speed sensitive intermittent wipe
- Fog lamp control
- Electro-Mechanical Instrument Cluster
- BCM diagnostic support
- Electronic Vehicle Information Center (EVIC) support
  - Customer programmable features, including:
    - Auto door locks
    - Horn chirp upon door lock with Remote Keyless Entry (RKE)
    - Low fuel warning chime
    - Headlights on with wipers (with auto headlamps only)

For diagnosis of the BCM or the PCI data bus, the use of a DRB scan tool and the proper Diagnostic Procedures manual are recommended. The BCM can only be serviced by an authorized electronic warranty repair station. Refer to the latest version of the Chrysler Corporation Warranty Policies and Procedures manual for a current listing of authorized electronic repair stations.

### OPERATION

The functions and features provided by the BCM are possible because of its hard wired inputs and outputs, as well as the resources it shares with other electronic modules in the vehicle through its communication over the PCI data bus network. The BCM uses its internal programming and all of these inputs to decide which functions it should perform and both the standard and optional features it should provide. Refer to **ELECTRONIC VEHICLE INFORMATION CENTER PROGRAMMING** in the Service Procedures section of Group 8V - Overhead Console Systems for more information on the customer programmable feature options.

## INSTRUMENT PANEL CIGAR LIGHTER

### DESCRIPTION

A cigar lighter receptacle is standard equipment on this model. On models equipped with the optional Smoker's Package, the cigar lighter knob and heating element are included. On models without the Smoker's Package, the cigar lighter receptacle is equipped with a snap fit plastic cap and is treated as an extra accessory power outlet. The cigar lighter receptacle is

## DESCRIPTION AND OPERATION (Continued)

installed in the instrument panel center lower bezel, which is located near the bottom of the instrument panel center stack area, below the heater and air conditioner controls. The cigar lighter base is secured by a snap fit within the center lower bezel.

The cigar lighter receptacle, plastic cap and the knob and heating element unit are available for service replacement. These components cannot be repaired and, if faulty or damaged, they must be replaced.

**OPERATION**

The cigar lighter consists of two major components: a knob and heating element unit, and the cigar lighter base or receptacle shell. The receptacle shell is connected to ground, and an insulated contact in the bottom of the shell is connected to battery current. The cigar lighter receives battery voltage from a fuse in the junction block through the cigar lighter relay only when the ignition switch is in the Accessory or On positions. Refer to **Cigar Lighter Relay** in the Description and Operation section of this group for more information on this component.

The cigar lighter knob and heating element are encased within a spring-loaded housing, which also features a sliding protective heat shield. When the knob and heating element are inserted in the receptacle shell, the heating element resistor coil is grounded through its housing to the receptacle shell. If the cigar lighter knob is pushed inward, the heat shield slides up toward the knob exposing the heating element, and the heating element extends from the housing toward the insulated contact in the bottom of the receptacle shell.

Two small spring-clip retainers are located on either side of the insulated contact inside the bottom of the receptacle shell. These clips engage and hold the heating element against the insulated contact long enough for the resistor coil to heat up. When the heating element is engaged with the contact, battery current can flow through the resistor coil to ground, causing the resistor coil to heat.

When the resistor coil becomes sufficiently heated, excess heat radiates from the heating element causing the spring-clips to expand. Once the spring-clips expand far enough to release the heating element, the spring-loaded housing forces the knob and heating element to pop back outward to their relaxed position. When the cigar lighter knob and element are pulled out of the receptacle shell, the protective heat shield slides downward on the housing so that the heating element is recessed and shielded around its circumference for safety.

**CIGAR LIGHTER RELAY****DESCRIPTION**

The cigar lighter relay is an electromechanical device that switches fused battery current to the cigar lighter when the ignition switch is turned to the Accessory or On positions. The cigar lighter relay is located in the junction block, below the driver side of the instrument panel in the passenger compartment.

The cigar lighter relay is a International Standards Organization (ISO) relay. Relays conforming to the ISO specifications have common physical dimensions, current capacities, terminal patterns, and terminal functions.

The cigar lighter relay cannot be repaired or adjusted and, if faulty or damaged, it must be replaced.

**OPERATION**

The ISO relay consists of an electromagnetic coil, a resistor or diode, and three (two fixed and one movable) electrical contacts. The movable (common feed) relay contact is held against one of the fixed contacts (normally closed) by spring pressure. When the electromagnetic coil is energized, it draws the movable contact away from the normally closed fixed contact, and holds it against the other (normally open) fixed contact.

When the electromagnetic coil is de-energized, spring pressure returns the movable contact to the normally closed position. The resistor or diode is connected in parallel with the electromagnetic coil in the relay, and helps to dissipate voltage spikes that are produced when the coil is de-energized.

**INSTRUMENT PANEL POWER OUTLET****DESCRIPTION**

An accessory power outlet is standard equipment on this model. The power outlet is installed in the instrument panel center lower bezel, which is located near the bottom of the instrument panel center stack area, below the heater and air conditioner controls. The power outlet base is secured by a snap fit within the center lower bezel. A hinged door with an over-center spring flips closed to conceal and protect the power outlet base when the power outlet is not being used, and flips open below the center lower bezel while the power outlet is in use.

The power outlet receptacle unit and the power outlet door are each available for service replacement.

## DESCRIPTION AND OPERATION (Continued)

**OPERATION**

The power outlet base or receptacle shell is connected to ground, and an insulated contact in the bottom of the shell is connected to battery current. The power outlet receives battery voltage from a fuse in the junction block at all times.

While the power outlet is very similar to a cigar lighter base unit, it does not include the two small spring-clip retainers inside the bottom of the receptacle shell that are used to secure the cigar lighter heating element to the insulated contact.

**DIAGNOSIS AND TESTING****INSTRUMENT CLUSTER**

Following are tests that will help to diagnose the hard wired components and circuits of the Electro-Mechanical Instrument Cluster (EMIC). However, these tests may not prove conclusive in the diagnosis of this unit. In order to obtain conclusive testing of the EMIC, the Programmable Communications Interface (PCI) data bus network and all of the electronic modules that provide inputs to, or receive outputs from the EMIC must be checked.

The most reliable, efficient, and accurate means to diagnose the EMIC requires the use of a DRB scan tool and the proper Diagnostic Procedures manual. The DRB scan tool can provide confirmation that the PCI data bus is functional, that all of the electronic modules are sending and receiving the proper messages on the PCI data bus, and that the EMIC is receiving the proper hard wired inputs to perform its many functions.

All of the gauges and many of the indicator lamps in the instrument cluster are controlled by messages received by the EMIC circuitry on the PCI data bus. Only the part-time four-wheel drive indicator lamp and the turn signal indicator lamps are hard wired in the instrument cluster.

The brake warning lamp receives a hard wired input from the park brake switch, but is also controlled by PCI data bus messages from the Controller Anti-lock Brake (CAB).

For complete circuit diagrams, refer to **Instrument Cluster** in the Contents of Group 8W - Wiring Diagrams.

**WARNING: ON VEHICLES EQUIPPED WITH AIRBAGS, REFER TO GROUP 8M - PASSIVE RESTRAINT SYSTEMS BEFORE ATTEMPTING ANY STEERING WHEEL, STEERING COLUMN, OR INSTRUMENT PANEL COMPONENT DIAGNOSIS OR SERVICE. FAILURE TO TAKE THE PROPER PRECAUTIONS COULD RESULT IN ACCIDENTAL AIRBAG DEPLOYMENT AND POSSIBLE PERSONAL INJURY.**

(1) Check the fused B(+) fuse in the junction block. If OK, go to Step 2. If not OK, repair the shorted circuit or component as required and replace the faulty fuse.

(2) Check for battery voltage at the fused B+ fuse in the junction block. If OK, go to Step 3. If not OK, repair the open fused B(+) circuit to the Power Distribution Center (PDC) fuse as required.

(3) Check the fused ignition switch output (run/start) fuse in the junction block. If OK, go to Step 4. If not OK, repair the shorted circuit or component as required and replace the faulty fuse.

(4) Turn the ignition switch to the On position. Check for battery voltage at the fused ignition switch output (start/run) fuse in the junction block. If OK, go to Step 5. If not OK, repair the open fused ignition switch output (start/run) circuit to the ignition switch as required.

(5) Turn the ignition switch to the Off position. Disconnect and isolate the battery negative cable. Remove the instrument cluster as described in this group. Reconnect the battery negative cable. Check for battery voltage at the fused B(+) circuit cavity of the instrument panel wire harness connector for the instrument cluster. If OK, go to Step 6. If not OK, repair the open fused B(+) circuit to the junction block fuse as required.

(6) Turn the ignition switch to the On position. Check for battery voltage at the fused ignition switch output (start/run) circuit cavity of the instrument panel wire harness connector for the instrument cluster. If OK, go to Step 7. If not OK, repair the open fused ignition switch output (start/run) circuit to the junction block fuse as required.

(7) Turn the ignition switch to the Off position. Disconnect and isolate the battery negative cable. Probe each of the ground circuit cavities of the instrument panel wire harness connector for the instrument cluster. Check for continuity to a good ground. There should be continuity. If OK, use a DRB scan tool and the proper Diagnostic Procedures manual for diagnosis of the instrument cluster circuitry and the PCI data bus. If not OK, repair the open ground circuit(s) to ground as required.

**HARD WIRED LAMP DIAGNOSIS**

Each of the lamps found in this section depends upon a hard wired circuit input to the instrument cluster for proper operation. The following procedures will help to diagnose conditions that may cause an inoperative hard wired lamp circuit condition.

## DIAGNOSIS AND TESTING (Continued)

**WARNING: ON VEHICLES EQUIPPED WITH AIR-BAGS, REFER TO GROUP 8M - PASSIVE RESTRAINT SYSTEMS BEFORE ATTEMPTING ANY STEERING WHEEL, STEERING COLUMN, OR INSTRUMENT PANEL COMPONENT DIAGNOSIS OR SERVICE. FAILURE TO TAKE THE PROPER PRECAUTIONS COULD RESULT IN ACCIDENTAL AIR-BAG DEPLOYMENT AND POSSIBLE PERSONAL INJURY.**

**BRAKE WARNING LAMP**

The diagnosis found here addresses an inoperative brake warning lamp condition. If the brake warning lamp stays on with the ignition switch in the On position and the park brake released, or comes on while driving, refer to **Antilock Brakes** in the Diagnosis and Testing section of Group 5 - Brakes for further diagnosis. If no brake system problem is found, the following procedure will help locate a short or open circuit, or a faulty switch. For complete circuit diagrams, refer to **Instrument Cluster** in the Contents of Group 8W - Wiring Diagrams.

(1) Turn the ignition switch to the Off position. Disconnect and isolate the battery negative cable. Disconnect the wire harness connector at the park brake switch. With the park brake released, check for continuity between the park brake switch terminal and a good ground. There should be no continuity. If OK, go to Step 2. If not OK, adjust or replace the faulty park brake switch.

(2) Remove the instrument cluster and disconnect the instrument panel wire harness connector from the instrument cluster. Check for continuity between the red brake warning indicator driver circuit cavity of the instrument panel wire harness connector for the instrument cluster and a good ground. There should be no continuity. If OK, go to Step 3. If not OK, repair the shorted red brake warning indicator driver circuit as required.

(3) Check for continuity between the red brake warning indicator driver circuit cavities of the instrument wire harness connector for the instrument cluster and the brake warning switch wire harness connector. There should be continuity. If OK, replace the faulty bulb. If not OK, repair the open red brake warning indicator driver circuit as required.

**FOUR-WHEEL DRIVE INDICATOR LAMP - PART TIME**

The diagnosis found here addresses an inoperative four-wheel drive indicator lamp condition. If the problem being diagnosed is related to lamp accuracy, be certain to confirm that the problem is with the lamp or switch and not with a damaged or inoperative transfer case or transfer case linkage. Refer to **NV242 Diagnosis** in the Diagnosis and Testing section of Group 21 - Transmission for more informa-

tion. If no transfer case problem is found, the following procedure will help locate a short or open in the indicator lamp circuit. For complete circuit diagrams, refer to **Instrument Cluster** in the Contents of Group 8W - Wiring Diagrams.

(1) Check the fused ignition switch output (run/start) fuse in the junction block. If OK, go to Step 2. If not OK, repair the shorted circuit or component as required and replace the faulty fuse.

(2) Turn the ignition switch to the On position. Check for battery voltage at the fused ignition switch output (run/start) fuse in the junction block. If OK, go to Step 3. If not OK, repair the open fused ignition switch output (run/start) circuit to the ignition switch as required.

(3) Turn the ignition switch to the Off position. Disconnect and isolate the battery negative cable. Disconnect the transfer case switch wire harness connector. Check for continuity between the ground circuit cavity of the transfer case switch wire harness connector and a good ground. There should be continuity. If OK, go to Step 4. If not OK, repair the open ground circuit to ground as required.

(4) Connect the battery negative cable. Turn the ignition switch to the On position. Install a jumper wire between the part time four wheel drive indicator lamp driver circuit cavity of the transfer case switch wire harness connector and a good ground. The part time four-wheel drive indicator lamp should light. If OK, replace the faulty transfer case switch. If not OK, go to Step 5.

(5) Turn the ignition switch to the Off position. Disconnect and isolate the battery negative cable. Remove the instrument cluster. With the transfer case switch wire harness connector still disconnected, check for continuity between the part time four wheel drive indicator lamp driver circuit cavity of the instrument panel wire harness connector for the instrument cluster and a good ground. There should be no continuity. If OK, go to Step 6. If not OK, repair the shorted part time four wheel drive indicator lamp driver circuit as required.

(6) Check for continuity between the part time four wheel drive indicator lamp driver circuit cavities of the instrument panel wire harness connector for the instrument cluster and the transfer case switch wire harness connector. There should be continuity. If OK, replace the faulty bulb. If not OK, repair the open part time four wheel drive indicator lamp driver circuit as required.

**TURN SIGNAL INDICATOR LAMP**

The diagnosis found here addresses an inoperative turn signal indicator lamp condition. For any other turn signal problem, refer to **Turn Signal and Hazard Warning Systems** in the Diagnosis and Testing



## DIAGNOSIS AND TESTING (Continued)

section of Group 8J - Turn Signal and Hazard Warning Systems for further diagnosis. If no turn signal or hazard warning system problem is found, the following procedure will help locate a short or open in the indicator lamp circuit. For complete circuit diagrams, refer to **Instrument Cluster** in the Contents of Group 8W - Wiring Diagrams.

(1) Disconnect and isolate the battery negative cable. Remove the instrument cluster and disconnect the instrument panel wire harness connector from the instrument cluster connector receptacle.

(2) Connect the battery negative cable. Activate the hazard warning system by moving the hazard warning switch button to the On position. Check for battery voltage at the inoperative (right or left) turn signal circuit cavity of the instrument panel wire harness connector for the instrument cluster. There should be a switching (on and off) battery voltage signal. If OK, replace the faulty (right or left) indicator lamp bulb. If not OK, repair the open (right or left) turn signal circuit to the electronic combination flasher in the junction block as required.

## BODY CONTROL MODULE

In order to obtain conclusive testing of the Body Control Module (BCM), all of the electronic modules that provide inputs to, or receive outputs from the BCM must also be checked. The most reliable, efficient, and accurate means to diagnose the BCM requires the use of a DRB scan tool and the proper Diagnostic Procedures manual. The DRB scan tool can provide confirmation that the Programmable Communications Interface (PCI) data bus network is functional, that all of the electronic modules are sending and receiving the proper messages on the PCI data bus, and that the BCM is receiving the proper hard wired inputs and relaying the proper hard wired outputs to perform its many functions.

Refer to **Body Control Module** in the Contents of Group 8W - Wiring Diagrams for complete circuit diagrams.

## INSTRUMENT PANEL CIGAR LIGHTER

For complete circuit diagrams, refer to **Horn/Cigar Lighter/Power Outlet** in the Contents of Group 8W - Wiring Diagrams.

**WARNING: ON VEHICLES EQUIPPED WITH AIR-BAGS, REFER TO GROUP 8M - PASSIVE RESTRAINT SYSTEMS BEFORE ATTEMPTING ANY STEERING WHEEL, STEERING COLUMN, OR INSTRUMENT PANEL COMPONENT DIAGNOSIS OR SERVICE. FAILURE TO TAKE THE PROPER PRECAUTIONS COULD RESULT IN ACCIDENTAL AIR-BAG DEPLOYMENT AND POSSIBLE PERSONAL INJURY.**

(1) Check the fused B(+) fuse in the junction block. If OK, go to Step 2. If not OK, repair the shorted circuit or component as required and replace the faulty fuse.

(2) Turn the ignition switch to the On position. Check for battery voltage at the fused B(+) fuse in the junction block. If OK, go to Step 3. If not OK, refer to **Cigar Lighter Relay** in the Diagnosis and Testing section of this group.

(3) Remove the cigar lighter knob and element from the cigar lighter receptacle shell. Check for continuity between the inside circumference of the cigar lighter receptacle shell and a good ground. There should be continuity. If OK, go to Step 4. If not OK, go to Step 5.

(4) Turn the ignition switch to the On position. Check for battery voltage at the insulated contact located at the back of the cigar lighter receptacle shell. If OK, replace the faulty cigar lighter knob and element. If not OK, go to Step 5.

(5) Turn the ignition switch to the Off position. Disconnect and isolate the battery negative cable. Remove the instrument panel center lower bezel. Check for continuity between the ground circuit cavity of the cigar lighter wire harness connector and a good ground. There should be continuity. If OK, go to Step 6. If not OK, repair the open ground circuit to ground as required.

(6) Connect the battery negative cable. Turn the ignition switch to the Accessory or On positions. Check for battery voltage at the fused B(+) circuit cavity of the cigar lighter wire harness connector. If OK, replace the faulty cigar lighter receptacle. If not OK, repair the open fused B(+) circuit to the junction block fuse as required.

## CIGAR LIGHTER RELAY

The cigar lighter relay (Fig. 1) is located in the junction block, below the driver side end of the instrument panel in the passenger compartment. For complete circuit diagrams, refer to **Horn/Cigar Lighter/Power Outlet** in the Contents of Group 8W - Wiring Diagrams.

**WARNING: ON VEHICLES EQUIPPED WITH AIR-BAGS, REFER TO GROUP 8M - PASSIVE RESTRAINT SYSTEMS BEFORE ATTEMPTING ANY STEERING WHEEL, STEERING COLUMN, OR INSTRUMENT PANEL COMPONENT DIAGNOSIS OR SERVICE. FAILURE TO TAKE THE PROPER PRECAUTIONS COULD RESULT IN ACCIDENTAL AIR-BAG DEPLOYMENT AND POSSIBLE PERSONAL INJURY.**

## DIAGNOSIS AND TESTING (Continued)

(1) Remove the cigar lighter relay from the junction block. Refer to **Cigar Lighter Relay** in the Removal and Installation section of this group for the procedures.

(2) A relay in the de-energized position should have continuity between terminals 87A and 30, and no continuity between terminals 87 and 30. If OK, go to Step 3. If not OK, replace the faulty relay.

(3) Resistance between terminals 85 and 86 (electromagnet) should be  $75 \pm 5$  ohms. If OK, go to Step 4. If not OK, replace the faulty relay.

(4) Connect a battery to terminals 85 and 86. There should now be continuity between terminals 30 and 87, and no continuity between terminals 87A and 30. If OK, perform the Relay Circuit Test that follows. If not OK, replace the faulty relay.

(4) The coil ground terminal (85) is connected to the electromagnet in the relay. It receives battery feed to energize the cigar lighter relay when the ignition switch is in the Accessory or On positions. Turn the ignition switch to the On position. Check for battery voltage at the fused ignition switch output (acc/run) circuit cavity for relay terminal 85 in the junction block receptacle for the cigar lighter relay. If OK, go to Step 5. If not OK, repair the open fused ignition switch output (acc/run) circuit to the ignition switch as required.

(5) The coil battery terminal (86) is connected to the electromagnet in the relay. The junction block cavity for this terminal should have continuity to ground at all times. If not OK, repair the open ground circuit to ground as required.

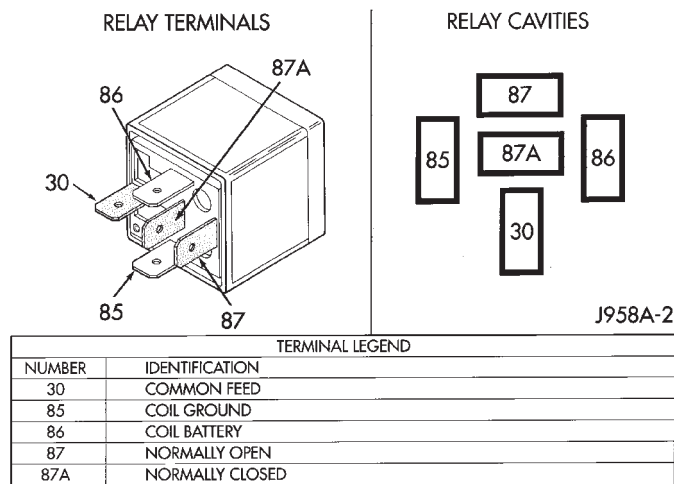

Fig. 1 Cigar Lighter Relay

## RELAY CIRCUIT TEST

(1) The relay common feed terminal cavity (30) of the junction block is connected to battery voltage and should be hot at all times. Check for battery voltage at the fused B(+) circuit cavity in the junction block receptacle for the cigar lighter relay. If OK, go to Step 2. If not OK, repair the fused B(+) circuit to the Power Distribution Center (PDC) fuse as required.

(2) The relay normally closed terminal (87A) is connected to terminal 30 in the de-energized position, but is not used for this application. Go to Step 3.

(3) The relay normally open terminal (87) is connected to the common feed terminal (30) in the energized position. This terminal supplies battery voltage to the fused B(+) fuse in the junction block that feeds the cigar lighter when the relay is energized by the ignition switch. There should be continuity between the junction block cavity for relay terminal 87 and the fused B(+) fuse in the junction block at all times. If OK, go to Step 4. If not OK, repair the open fused B(+) circuit to the junction block fuse as required.

## INSTRUMENT PANEL POWER OUTLET

For complete circuit diagrams, refer to **Horn/Cigar Lighter/Power Outlet** in the Contents of Group 8W - Wiring Diagrams.

**WARNING: ON VEHICLES EQUIPPED WITH AIRBAGS, REFER TO GROUP 8M - PASSIVE RESTRAINT SYSTEMS BEFORE ATTEMPTING ANY STEERING WHEEL, STEERING COLUMN, OR INSTRUMENT PANEL COMPONENT DIAGNOSIS OR SERVICE. FAILURE TO TAKE THE PROPER PRECAUTIONS COULD RESULT IN ACCIDENTAL AIRBAG DEPLOYMENT AND POSSIBLE PERSONAL INJURY.**

(1) Check the fused B(+) fuse in the junction block. If OK, go to Step 2. If not OK, repair the shorted circuit or component as required and replace the faulty fuse.

(2) Check for battery voltage at the fused B(+) fuse in the junction block. If OK, go to Step 3. If not OK, repair the open fused B(+) circuit to the Power Distribution Center (PDC) fuse as required.

(3) Open the power outlet door. Check for continuity between the inside circumference of the power outlet receptacle and a good ground. There should be continuity. If OK, go to Step 4. If not OK, go to Step 5.

(4) Check for battery voltage at the insulated contact located at the back of the power outlet receptacle. If not OK, go to Step 5.

(5) Disconnect and isolate the battery negative cable. Remove the instrument panel center lower bezel. Check for continuity between the ground circuit cavity of the power outlet wire harness connector and a good ground. There should be continuity. If OK, go to Step 6. If not OK, repair the open ground circuit to ground as required.

(6) Connect the battery negative cable. Check for battery voltage at the fused B(+) circuit cavity of the

DIAGNOSIS AND TESTING (Continued)

power outlet wire harness connector. If OK, replace the faulty power outlet receptacle. If not OK, repair the open fused B(+) circuit to the junction block fuse as required.

REMOVAL AND INSTALLATION

INSTRUMENT PANEL FUSE COVER

**WARNING: ON VEHICLES EQUIPPED WITH AIRBAGS, REFER TO GROUP 8M - PASSIVE RESTRAINT SYSTEMS BEFORE ATTEMPTING ANY STEERING WHEEL, STEERING COLUMN, OR INSTRUMENT PANEL COMPONENT DIAGNOSIS OR SERVICE. FAILURE TO TAKE THE PROPER PRECAUTIONS COULD RESULT IN ACCIDENTAL AIRBAG DEPLOYMENT AND POSSIBLE PERSONAL INJURY.**

REMOVAL

- (1) Disconnect and isolate the battery negative cable.
- (2) Pull down on the rear edge (nearest the rear of the vehicle) of the instrument panel fuse cover until the rear latches unsnap from the tabs on the lower junction block housing and the side latch unsnaps from the tab on the instrument panel steering column support bracket outboard of the 16-way data link connector (Fig. 2).

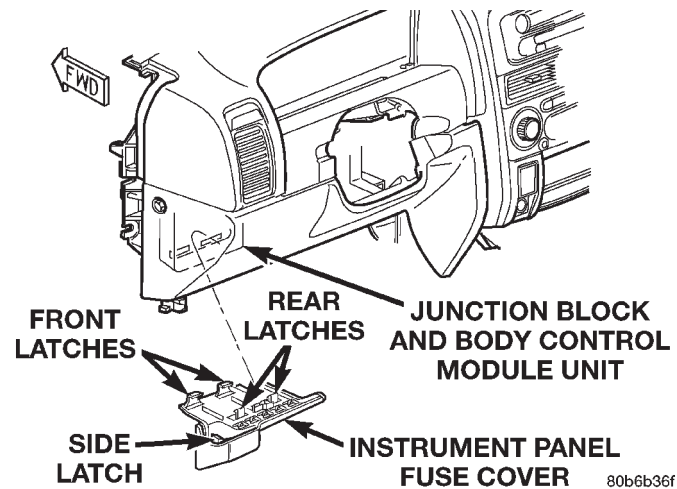
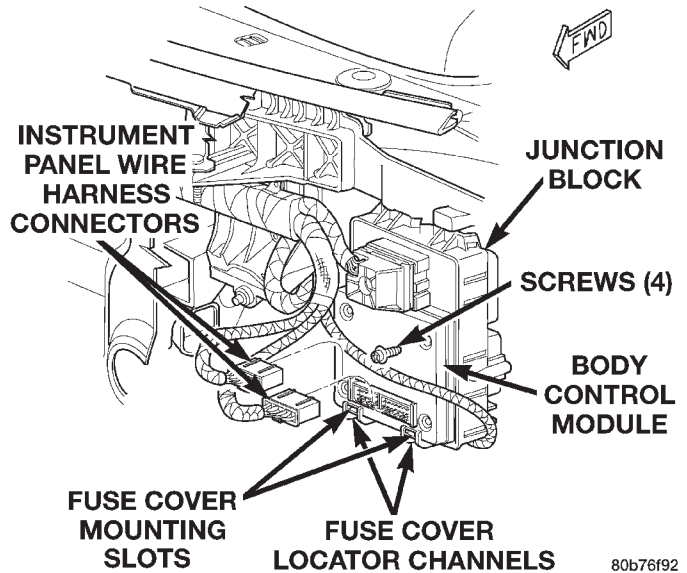

**Fig. 2 Instrument Panel Fuse Cover Remove/Install**

- (3) Move the instrument panel fuse cover towards the front of the vehicle to disengage the front latches from the mounting slots in the lower housing of the body control module.
- (4) Remove the fuse cover from under the instrument panel.

INSTALLATION

- (1) Position the two front latches of the instrument panel fuse cover within the two locator channel formations on the bottom of the body control module housing (Fig. 3).



**Fig. 3 Instrument Panel Fuse Cover Locator Channels**

- (2) While applying a slight upward pressure to the instrument panel fuse cover over the front latches, slowly slide the front latches through the locator channels toward the front of the vehicle until the latches exit the front of the locator channels. This will locate the front latches at the mounting slots in the lower housing of the body control module.
- (3) Apply a slight rearward pressure on the instrument panel fuse cover to engage the front latches in the mounting slots in the lower housing of the body control module.
- (4) Swing the rear edge (nearest the rear of the vehicle) of the instrument panel fuse cover up toward the junction block.
- (5) Press firmly upward on the instrument panel fuse cover over the rear latches until the latches snap into place over the tabs on the lower edge of the junction block housing.
- (6) Press firmly upward on the 16-way data link connector cover formation of the instrument panel fuse cover until the side latch snaps into place over the tab on the outboard side of the instrument panel steering column support bracket.
- (7) Reconnect the battery negative cable.

## REMOVAL AND INSTALLATION (Continued)

## BODY CONTROL MODULE

**WARNING: ON VEHICLES EQUIPPED WITH AIR-BAGS, REFER TO GROUP 8M - PASSIVE RESTRAINT SYSTEMS BEFORE ATTEMPTING ANY STEERING WHEEL, STEERING COLUMN, OR INSTRUMENT PANEL COMPONENT DIAGNOSIS OR SERVICE. FAILURE TO TAKE THE PROPER PRECAUTIONS COULD RESULT IN ACCIDENTAL AIR-BAG DEPLOYMENT AND POSSIBLE PERSONAL INJURY.**

## REMOVAL

(1) Disconnect and isolate the battery negative cable.

(2) Remove the instrument panel fuse cover from the bottom of the junction block and body control module unit. Refer to **Instrument Panel Fuse Cover** in the Removal and Installation section of this group for the procedures.

(3) Reach under the instrument panel and behind the junction block to disconnect the two instrument panel wire harness connectors from the body control module connector receptacles (Fig. 4).

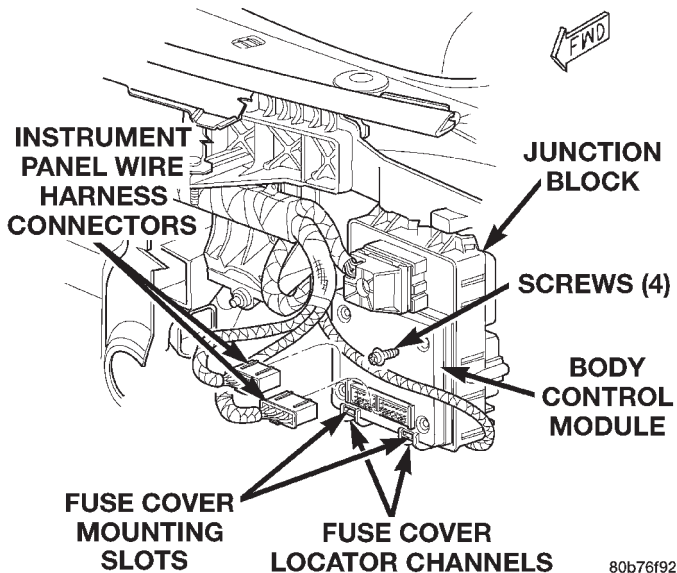

**Fig. 4 Body Control Module Remove/Install**

(4) Remove the four screws (Torx T-20) that secure the body control module to the junction block.

(5) Pull the body control module straight out from the junction block until the integral connector is completely disengaged.

(6) Remove the body control module from under the instrument panel.

## INSTALLATION

(1) Reach under the instrument panel and behind the junction block to position the body control module to its mounting location on the junction block.

(2) Align the integral connector terminal pins of the body control module with the integral connector receptacle on the junction block.

(3) Firmly and evenly squeeze the body control module and the junction block together until the integral connector is fully engaged.

(4) Install and tighten the four screws that secure the body control module to the junction block. Tighten the screws to 2.2 N·m (20 in. lbs.).

(5) Reconnect the two instrument panel wire harness connectors to the body control module connector receptacles.

(6) Install the instrument panel fuse cover to the bottom of the junction block and body control module unit. Refer to **Instrument Panel Fuse Cover** in the Removal and Installation section of this group for the procedures.

(7) Reconnect the battery negative cable.

## INSTRUMENT PANEL DRIVER SIDE COURTESY LAMP BRACKET

**WARNING: ON VEHICLES EQUIPPED WITH AIR-BAGS, REFER TO GROUP 8M - PASSIVE RESTRAINT SYSTEMS BEFORE ATTEMPTING ANY STEERING WHEEL, STEERING COLUMN, OR INSTRUMENT PANEL COMPONENT DIAGNOSIS OR SERVICE. FAILURE TO TAKE THE PROPER PRECAUTIONS COULD RESULT IN ACCIDENTAL AIR-BAG DEPLOYMENT AND POSSIBLE PERSONAL INJURY.**

## REMOVAL

(1) Disconnect and isolate the battery negative cable.

(2) Remove the instrument panel fuse cover from the bottom of the junction block and body control module unit. Refer to **Instrument Panel Fuse Cover** in the Removal and Installation section of this group for the procedures.

(3) Reach under the steering column opening cover to access and remove the screw that secures the courtesy lamp to the lower end of the instrument panel bracket near the inboard side of the junction block (Fig. 5).

(4) Remove the courtesy lamp from the lower end of the instrument panel driver side courtesy lamp bracket.

(5) Reach under the steering column opening cover to access and remove the screw that secures the courtesy lamp bracket and the inboard side of the junc-

REMOVAL AND INSTALLATION (Continued)

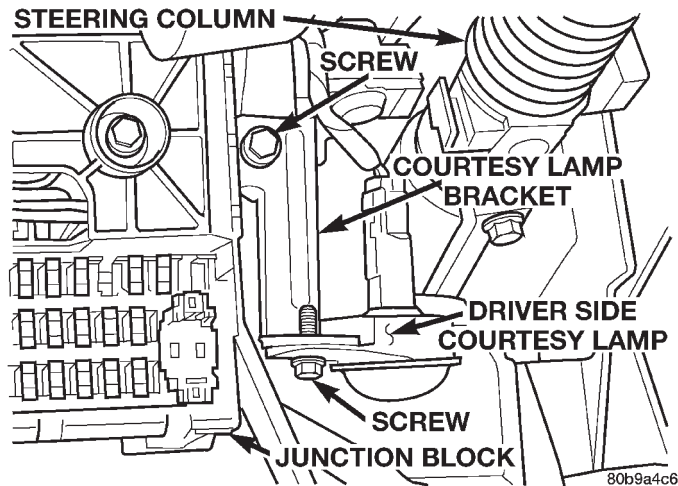

**Fig. 5 Instrument Panel Driver Side Courtesy Lamp Bracket Remove/Install**

tion block to the instrument panel steering column support bracket.

(6) Remove the driver side courtesy lamp bracket from under the instrument panel.

**INSTALLATION**

(1) Reach under the instrument panel to position the upper end of the driver side courtesy lamp bracket to the instrument panel steering column support bracket.

(2) Install and tighten the screw that secures the courtesy lamp bracket and the inboard side of the junction block to the instrument panel steering column support bracket. Tighten the screw to 2.2 N·m (20 in. lbs.).

(3) Position the courtesy lamp to the lower end of the instrument panel driver side courtesy lamp bracket.

(4) Install and tighten the screw that secures the courtesy lamp to the lower end of the instrument panel driver side courtesy lamp bracket. Tighten the screw to 2.2 N·m (20 in. lbs.).

(5) Install the instrument panel fuse cover to the bottom of the junction block and body control module unit. Refer to **Instrument Panel Fuse Cover** in the Removal and Installation section of this group for the procedures.

(6) Reconnect the battery negative cable.

**INSTRUMENT PANEL DRIVER SIDE BEZEL**

**WARNING: ON VEHICLES EQUIPPED WITH AIR-BAGS, REFER TO GROUP 8M - PASSIVE RESTRAINT SYSTEMS BEFORE ATTEMPTING ANY STEERING WHEEL, STEERING COLUMN, OR INSTRUMENT PANEL COMPONENT DIAGNOSIS OR SERVICE. FAILURE TO TAKE THE PROPER PRECAUTIONS COULD RESULT IN ACCIDENTAL AIR-**

**BAG DEPLOYMENT AND POSSIBLE PERSONAL INJURY.**

**REMOVAL**

(1) Disconnect and isolate the battery negative cable.

(2) Using a trim stick or another suitable wide flat-bladed tool, gently pry the edges of the driver side bezel up and away from the instrument panel far enough to disengage the two snap clips from their receptacles (Fig. 6).

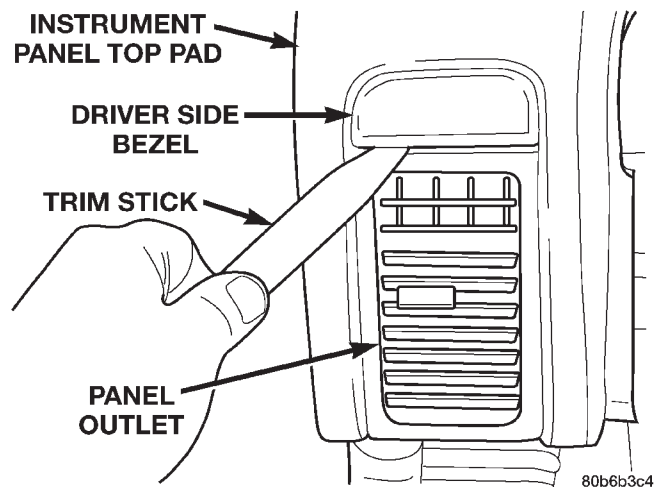

**Fig. 6 Instrument Panel Driver Side Bezel Remove/Install**

(3) Remove the driver side bezel from the instrument panel top pad.

**INSTALLATION**

(1) Position the driver side bezel to the instrument panel top pad.

(2) Align the snap clips on the driver side bezel with the receptacles in the instrument panel top pad.

(3) Press firmly on the instrument panel driver side bezel over the snap clip locations until each of the snap clips is fully engaged in its receptacle.

(4) Reconnect the battery negative cable.

**CLUSTER BEZEL**

**WARNING: ON VEHICLES EQUIPPED WITH AIR-BAGS, REFER TO GROUP 8M - PASSIVE RESTRAINT SYSTEMS BEFORE ATTEMPTING ANY STEERING WHEEL, STEERING COLUMN, OR INSTRUMENT PANEL COMPONENT DIAGNOSIS OR SERVICE. FAILURE TO TAKE THE PROPER PRECAUTIONS COULD RESULT IN ACCIDENTAL AIR-BAG DEPLOYMENT AND POSSIBLE PERSONAL INJURY.**

## REMOVAL AND INSTALLATION (Continued)

## REMOVAL

- (1) Disconnect and isolate the battery negative cable.
- (2) Place the tilt steering wheel in its fully lowered position.
- (3) Using a trim stick or another suitable wide flat-bladed tool, gently pry each of the four corners of the cluster bezel away from the instrument panel far enough to disengage the four snap clips from their receptacles (Fig. 7).

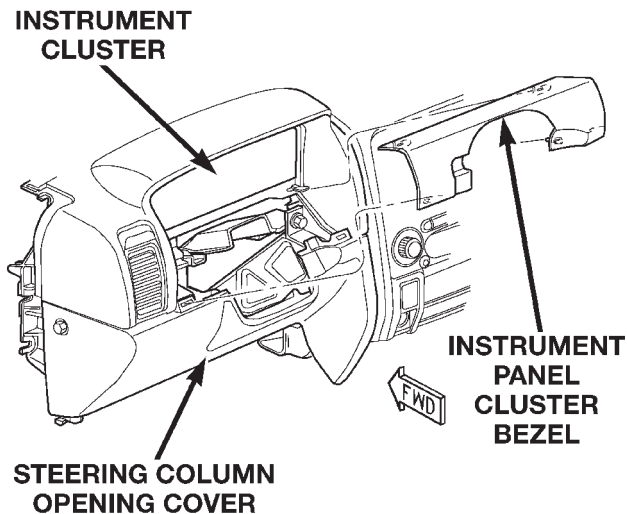

80b6b2db

Fig. 7 Cluster Bezel Remove/Install

- (4) Being certain not to scratch the instrument cluster lens with the two snap clips on the lower edge of the cluster bezel, roll the top of the cluster bezel rearward over the top of the steering column to remove it from the instrument panel.

## INSTALLATION

- (1) Being certain not to scratch the instrument cluster lens with the two snap clips on the lower edge of the cluster bezel, slide the lower edge of the cluster bezel forward and down over the top of the steering column to position it on the instrument panel.
- (2) Align the two snap clips on the lower edge of the cluster bezel with the receptacles on the instrument panel.
- (3) Press firmly on the cluster bezel over each of the lower snap clip locations until each of the snap clips is fully engaged in its receptacle.
- (4) Align the two receptacles on the upper edge of the cluster bezel with the snap clips on the instrument panel.
- (5) Press firmly on the cluster bezel over each of the upper snap clip locations until each of the snap clips is fully engaged in its receptacle.

- (6) Reconnect the battery negative cable.

## STEERING COLUMN OPENING COVER

**WARNING: ON VEHICLES EQUIPPED WITH AIR-BAGS, REFER TO GROUP 8M - PASSIVE RESTRAINT SYSTEMS BEFORE ATTEMPTING ANY STEERING WHEEL, STEERING COLUMN, OR INSTRUMENT PANEL COMPONENT DIAGNOSIS OR SERVICE. FAILURE TO TAKE THE PROPER PRECAUTIONS COULD RESULT IN ACCIDENTAL AIR-BAG DEPLOYMENT AND POSSIBLE PERSONAL INJURY.**

## REMOVAL

- (1) Disconnect and isolate the battery negative cable.
- (2) Remove the fuse cover from the junction block under the instrument panel. Refer to **Instrument Panel Fuse Cover** in the Removal and Installation section of this group for the procedures.
- (3) Remove the cluster bezel from the instrument panel. Refer to **Cluster Bezel** in the Removal and Installation section of this group for the procedures.
- (4) Remove the one screw that secures the outboard end of the steering column opening cover to the U-nut on the instrument panel top pad (Fig. 8).

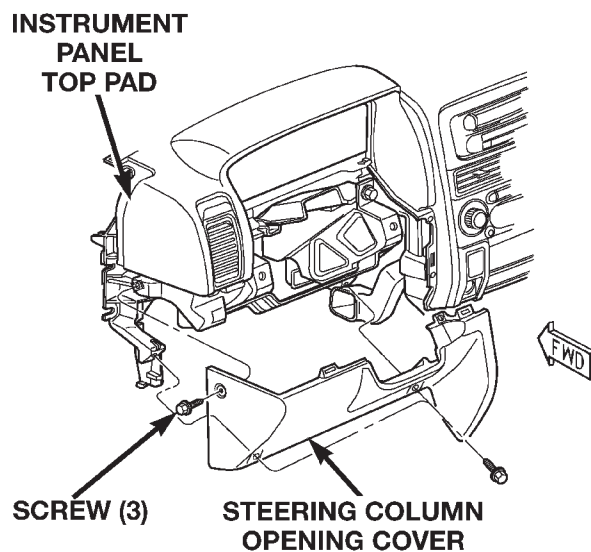

80b6b30e

Fig. 8 Steering Column Opening Cover Remove/Install

- (5) Remove the two screws that secure the lower edge of the steering column opening cover to the U-nuts on the instrument panel steering column support bracket.
- (6) Pull the steering column opening cover rearward to disengage the three snap clips (one outboard

REMOVAL AND INSTALLATION (Continued)

and two inboard that secure it to the instrument panel.

(7) Remove the steering column opening cover from the instrument panel.

**INSTALLATION**

(1) Position the steering column opening cover to the instrument panel.

(2) Align the three snap clips on the steering column opening cover with the receptacles on the instrument panel.

(3) Press firmly on the steering column opening cover over the snap clip locations until each of the snap clips is fully engaged in its receptacle.

(4) Install and tighten the two screws that secure the lower edge of the steering column opening cover to the instrument panel steering column support bracket. Tighten the screws to 2.2 N·m (20 in. lbs.).

(5) Install and tighten the one screw that secures the outboard end of the steering column opening cover to the U-nut on the instrument panel top pad. Tighten the screw to 2.2 N·m (20 in. lbs.).

(6) Install the cluster bezel onto the instrument panel. Refer to **Cluster Bezel** in the Removal and Installation section of this group for the procedures.

(7) Install the fuse cover onto the junction block under the instrument panel. Refer to **Instrument Panel Fuse Cover** in the Removal and Installation section of this group for the procedures.

(8) Reconnect the battery negative cable.

**INSTRUMENT PANEL STEERING COLUMN BRACKET**

**WARNING: ON VEHICLES EQUIPPED WITH AIR-BAGS, REFER TO GROUP 8M - PASSIVE RESTRAINT SYSTEMS BEFORE ATTEMPTING ANY STEERING WHEEL, STEERING COLUMN, OR INSTRUMENT PANEL COMPONENT DIAGNOSIS OR SERVICE. FAILURE TO TAKE THE PROPER PRECAUTIONS COULD RESULT IN ACCIDENTAL AIR-BAG DEPLOYMENT AND POSSIBLE PERSONAL INJURY.**

**REMOVAL**

(1) Disconnect and isolate the battery negative cable.

(2) Remove the steering column opening cover from the instrument panel. Refer to **Steering Column Opening Cover** in the Removal and Installation section of this group for the procedures.

(3) Remove the four screws that secure the steering column bracket to the instrument panel steering column support bracket (Fig. 9).

**INSTRUMENT PANEL STEERING COLUMN SUPPORT BRACKET**

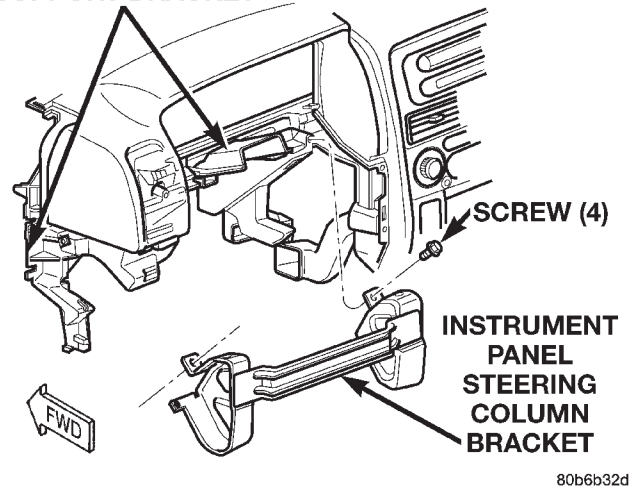

**Fig. 9 Instrument Panel Steering Column Bracket Remove/Install**

(4) Remove the steering column bracket from the instrument panel steering column support bracket.

**INSTALLATION**

(1) Position the steering column bracket to the instrument panel steering column support bracket.

(2) Install and tighten the four screws that secure the steering column bracket to the instrument panel steering column support bracket. Tighten the screws to 11.8 N·m (105 in. lbs.).

(3) Install the steering column opening cover. Refer to **Steering Column Opening Cover** in the Removal and Installation section of this group for the procedures.

(4) Reconnect the battery negative cable.

**INSTRUMENT CLUSTER**

**WARNING: ON VEHICLES EQUIPPED WITH AIR-BAGS, REFER TO GROUP 8M - PASSIVE RESTRAINT SYSTEMS BEFORE ATTEMPTING ANY STEERING WHEEL, STEERING COLUMN, OR INSTRUMENT PANEL COMPONENT DIAGNOSIS OR SERVICE. FAILURE TO TAKE THE PROPER PRECAUTIONS COULD RESULT IN ACCIDENTAL AIR-BAG DEPLOYMENT AND POSSIBLE PERSONAL INJURY.**

**REMOVAL**

(1) Disconnect and isolate the battery negative cable.

(2) Remove the cluster bezel from the instrument panel. Refer to **Cluster Bezel** in the Removal and Installation section of this group for the procedures.

## REMOVAL AND INSTALLATION (Continued)

(3) Remove the two screws that secure the upper mounting tabs of the instrument cluster to the underside of the instrument cluster hood formation of the instrument panel top pad.

(4) Remove the two screws that secure the lower mounting tabs of the instrument cluster to the instrument panel structural duct.

(5) Pull the upper mounting tabs of the instrument cluster downward, then pull the instrument cluster rearward far enough to access the instrument panel wire harness connector (Fig. 10).

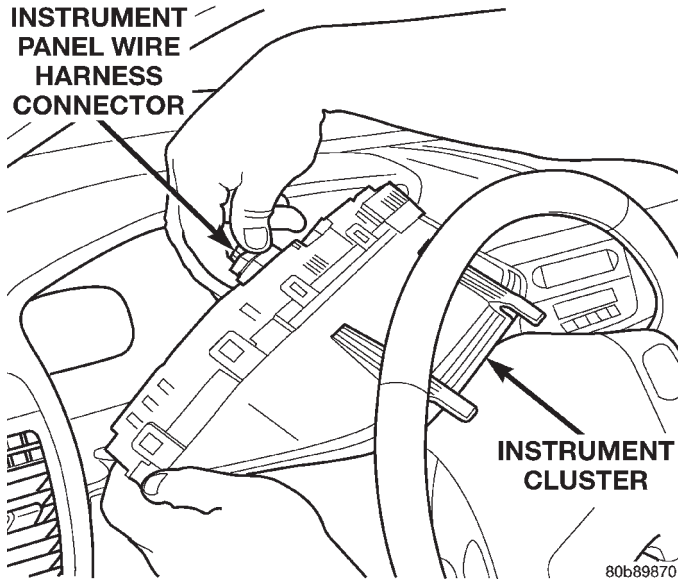

**Fig. 10 Instrument Cluster Remove/Install**

(6) Disconnect the one instrument panel wire harness connector from the connector receptacle on the back of the instrument cluster housing.

(7) Remove the instrument cluster from the instrument panel.

## INSTALLATION

(1) Position the instrument cluster to the instrument panel.

(2) Reconnect the one instrument panel wire harness connector to the connector receptacle on the back of the instrument cluster housing.

(3) Position the lower mounting tabs of the instrument cluster to the mounting holes on the instrument panel structural duct, then tilt the top of the instrument cluster forward until the upper mounting tabs are positioned to the mounting holes on the underside of the instrument cluster hood formation of the instrument panel top pad.

(4) Install and tighten the two screws that secure the upper mounting tabs of the instrument cluster to the underside of the instrument cluster hood formation of the instrument panel top pad. Tighten the screws to 2.2 N·m (20 in. lbs.).

(5) Install and tighten the two screws that secure the lower mounting tabs of the instrument cluster to the instrument panel structural duct. Tighten the screws to 2.2 N·m (20 in. lbs.).

(6) Install the cluster bezel onto the instrument panel. Refer to **Cluster Bezel** in the Removal and Installation section of this group for the procedures.

(7) Reconnect the battery negative cable.

## INSTRUMENT CLUSTER COMPONENTS

Many of the components for the instrument cluster used in this vehicle are serviced individually. The serviced components include: the trip odometer reset knob, the instrument cluster indicator lamp and illumination lamp bulbs (including the integral bulb holders), the major gauges (the speedometer and the tachometer) the minor gauge sets (the fuel gauge/voltmeter set and the coolant temperature gauge/oil pressure gauge set), the instrument cluster housing rear cover, and the instrument cluster housing (including the trip odometer reset switch stem and the instrument cluster electronic circuit board). Following are the service procedures for the instrument cluster components.

**WARNING: ON VEHICLES EQUIPPED WITH AIRBAGS, REFER TO GROUP 8M - PASSIVE RESTRAINT SYSTEMS BEFORE ATTEMPTING ANY STEERING WHEEL, STEERING COLUMN, OR INSTRUMENT PANEL COMPONENT DIAGNOSIS OR SERVICE. FAILURE TO TAKE THE PROPER PRECAUTIONS COULD RESULT IN ACCIDENTAL AIRBAG DEPLOYMENT AND POSSIBLE PERSONAL INJURY.**

## REMOVAL

## TRIP ODOMETER RESET KNOB

(1) Pull the trip odometer reset knob off of the tip of the trip odometer reset switch stem, which protrudes through the face of the cluster lens to the right of the speedometer (Fig. 12).

## CLUSTER BULB

This procedure applies to each of the cluster illumination lamp (five) or indicator lamp (up to 22) bulb and bulb holder units. However, the illumination lamps and the indicator lamps use different bulb and bulb holder unit sizes. They must never be interchanged. Be certain that any bulb holder removed from the electronic circuit board is reinstalled in the correct position. Always use the correct bulb size and type for replacement. An incorrect bulb size or type may overheat and cause damage to the instrument cluster, the electronic circuit board and/or the gauges.



REMOVAL AND INSTALLATION (Continued)

- (1) Disconnect and isolate the battery negative cable.
- (2) Remove the instrument cluster from the instrument panel. Refer to **Instrument Cluster** in the Removal and Installation section of this group for the procedures.
- (3) Turn the bulb holder counterclockwise about sixty degrees on the cluster electronic circuit board (Fig. 11).

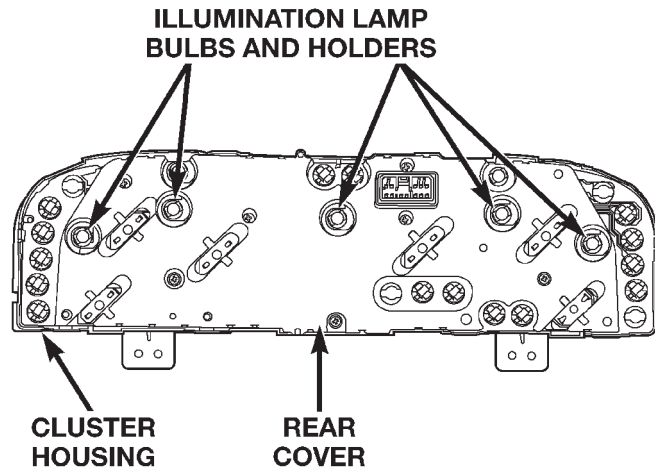

80b6b319

**Fig. 11 Cluster Bulb Locations**

- (4) Pull the bulb and bulb holder straight back to remove it from the bulb mounting hole in the cluster electronic circuit board.

CLUSTER LENS, HOOD AND MASK

- (1) Disconnect and isolate the battery negative cable.
- (2) Remove the knob from the trip odometer reset switch stem. Refer to **Instrument Cluster Components - Trip Odometer Reset Knob** in the Removal and Installation section of this group for the procedures.
- (3) Remove the instrument cluster from the instrument panel. Refer to **Instrument Cluster** in the Removal and Installation section of this group for the procedures.
- (4) Work around the perimeter of the cluster housing to disengage each of the eight latches that secure the cluster lens, hood and mask unit to the cluster housing (Fig. 12).
- (5) Gently pull the cluster lens, hood and mask unit away from the cluster housing.

CLUSTER HOUSING REAR COVER

- (1) Disconnect and isolate the battery negative cable.

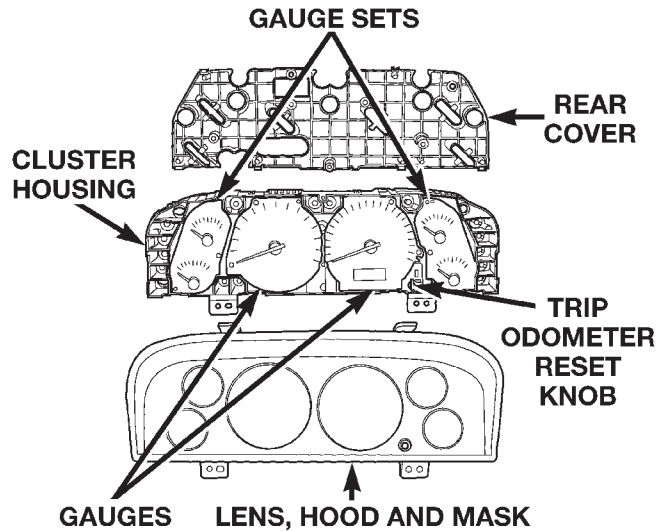

80b6b318

**Fig. 12 Instrument Cluster Components**

- (2) Remove the instrument cluster from the instrument panel. Refer to **Instrument Cluster** in the Removal and Installation section of this group for the procedures.
- (3) Remove the seven screws that secure the rear cover to the back of the cluster housing (Fig. 13).

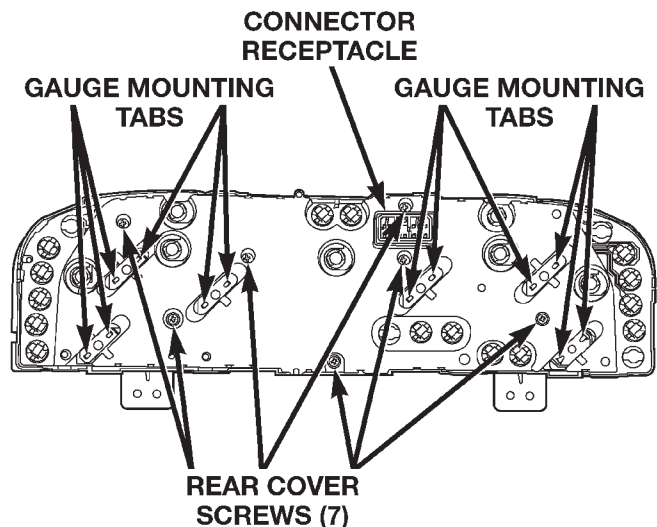

80b6b31a

**Fig. 13 Cluster Housing Rear Cover Screws**

- (4) Disengage the latches (two on top, four on the bottom) that secure the upper and lower edges of the rear cover to the top and bottom of the cluster housing.
- (5) Remove the rear cover from the back of the cluster housing.

## REMOVAL AND INSTALLATION (Continued)

## GAUGE

(1) Disconnect and isolate the battery negative cable.

(2) Remove the knob from the trip odometer reset switch stem. Refer to **Instrument Cluster Components - Trip Odometer Reset Knob** in the Removal and Installation section of this group for the procedures.

(3) Remove the instrument cluster from the instrument panel. Refer to **Instrument Cluster** in the Removal and Installation section of this group for the procedures.

(4) Remove the cluster lens, hood and mask unit from the cluster housing. Refer to **Instrument Cluster Components - Cluster Lens, Hood and Mask** in the Removal and Installation section of this group for the procedures.

(5) Remove the rear cover from the cluster housing. Refer to **Instrument Cluster Components - Cluster Housing Rear Cover** in the Removal and Installation section of this group for the procedures.

(6) From the rear of the cluster housing, carefully straighten the small metal mounting tabs (two for each major gauge, and four for each minor gauge set) that secure the gauge or gauge set to the cluster electronic circuit board (Fig. 13).

(7) From the front of the cluster housing, carefully pull the gauge or gauge set straight out of the gauge mounting cavity(ies) in the cluster housing.

## CLUSTER HOUSING

(1) Disconnect and isolate the battery negative cable.

(2) Remove the knob from the trip odometer reset switch stem. Refer to **Instrument Cluster Components - Trip Odometer Reset Knob** in the Removal and Installation section of this group for the procedures.

(3) Remove the instrument cluster from the instrument panel. Refer to **Instrument Cluster** in the Removal and Installation section of this group for the procedures.

(4) Remove all of the cluster illumination lamp and indicator lamp bulb and bulb holder units from the electronic circuit board. Refer to **Instrument Cluster Components - Cluster Bulbs** in the Removal and Installation section of this group for the procedures.

(5) Remove the cluster lens, hood and mask unit from the cluster housing. Refer to **Instrument Cluster Components - Cluster Lens, Hood and Mask** in the Removal and Installation section of this group for the procedures.

(6) Remove the rear cover from the cluster housing. Refer to **Instrument Cluster Components -**

**Cluster Housing Rear Cover** in the Removal and Installation section of this group for the procedures.

(7) Remove all of the cluster gauges and gauge sets from the cluster housing. Refer to **Instrument Cluster Components - Gauge** in the Removal and Installation section of this group for the procedures.

## INSTALLATION

## TRIP ODOMETER RESET KNOB

(1) Push the knob onto the tip of the trip odometer reset switch stem, which protrudes through the face of the cluster lens to the right of the speedometer.

## CLUSTER BULB

This procedure applies to each of the cluster illumination lamp (five) or indicator lamp (up to 22) bulb and bulb holder units. However, the illumination lamps and the indicator lamps use different bulb and bulb holder unit sizes. They must never be interchanged. Be certain that any bulb holder removed from the electronic circuit board is reinstalled in the correct position.

**CAUTION:** Always use the correct bulb size and type for replacement. An incorrect bulb size or type may overheat and cause damage to the instrument cluster, the electronic circuit board and/or the gauges.

(1) Insert the bulb and bulb holder straight into the correct bulb mounting hole in the cluster electronic circuit board.

(2) With the bulb holder fully seated against the cluster electronic circuit board, turn the bulb holder clockwise about sixty degrees to lock it into place.

(3) Install the instrument cluster into the instrument panel. Refer to **Instrument Cluster** in the Removal and Installation section of this group for the procedures.

(4) Reconnect the battery negative cable.

## CLUSTER LENS, HOOD AND MASK

(1) Align the cluster lens, hood and mask unit with the cluster housing.

(2) Press firmly and evenly on the cluster lens, hood and mask unit to install it onto the cluster housing.

(3) Work around the perimeter of the cluster housing to be certain that each of the eight latches that secure the cluster lens, hood and mask unit to the cluster housing is fully engaged.

(4) Install the instrument cluster into the instrument panel. Refer to **Instrument Cluster** in the Removal and Installation section of this group for the procedures.

## REMOVAL AND INSTALLATION (Continued)

(5) Install the knob onto the trip odometer reset switch stem. Refer to **Instrument Cluster Components - Trip Odometer Reset Knob** in the Removal and Installation section of this group for the procedures.

(6) Reconnect the battery negative cable.

## CLUSTER HOUSING REAR COVER

(1) Position the rear cover to the back of the cluster housing.

(2) Press firmly and evenly on the rear cover until each of the latches (two on top, four on the bottom) that secure the upper and lower edges of the rear cover to the top and bottom of the cluster housing is fully engaged.

(3) Install and tighten the seven screws that secure the rear cover to the back of the cluster housing. Tighten the screws to 2.2 N·m (20 in. lbs.).

(4) Install the instrument cluster into the instrument panel. Refer to **Instrument Cluster** in the Removal and Installation section of this group for the procedures.

(5) Reconnect the battery negative cable.

## GAUGE

(1) From the front of the cluster housing, carefully align the gauge or gauge set with the connector pins in the bottom of the gauge mounting cavity(ies) in the cluster housing.

(2) From the front of the cluster housing, press firmly and evenly on the gauge or gauge set to install it onto the connector pins and into the gauge mounting cavity(ies) in the cluster housing.

(3) From the rear of the cluster housing, be certain that the small metal mounting tabs (two for each major gauge, and four for each minor gauge set) that secure the gauge or gauge set are protruding through the mounting holes in the cluster electronic circuit board.

(4) From the rear of the cluster housing, carefully bend over the small metal mounting tabs (two for each major gauge, and four for each minor gauge set) to secure the gauge or gauge set to the cluster electronic circuit board.

(5) Install the rear cover onto the cluster housing. Refer to **Instrument Cluster Components - Cluster Housing Rear Cover** in the Removal and Installation section of this group for the procedures.

(6) Install the cluster lens, hood and mask unit onto the cluster housing. Refer to **Instrument Cluster Components - Cluster Lens, Hood and Mask** in the Removal and Installation section of this group for the procedures.

(7) Install the instrument cluster into the instrument panel. Refer to **Instrument Cluster** in the

Removal and Installation section of this group for the procedures.

(8) Install the knob onto the trip odometer reset switch stem. Refer to **Instrument Cluster Components - Trip Odometer Reset Knob** in the Removal and Installation section of this group for the procedures.

(9) Reconnect the battery negative cable.

## CLUSTER HOUSING

(1) Install all of the cluster gauges and gauge sets into the cluster housing. Refer to **Instrument Cluster Components - Gauge** in the Removal and Installation section of this group for the procedures.

(2) Install the rear cover onto the cluster housing. Refer to **Instrument Cluster Components - Cluster Housing Rear Cover** in the Removal and Installation section of this group for the procedures.

(3) Install the cluster lens, hood and mask unit onto the cluster housing. Refer to **Instrument Cluster Components - Cluster Lens, Hood and Mask** in the Removal and Installation section of this group for the procedures.

(4) Install all of the cluster illumination lamp and indicator lamp bulb and bulb holder units into the electronic circuit board. Refer to **Instrument Cluster Components - Cluster Bulbs** in the Removal and Installation section of this group for the procedures.

(5) Install the instrument cluster into the instrument panel. Refer to **Instrument Cluster** in the Removal and Installation section of this group for the procedures.

(6) Install the knob onto the trip odometer reset switch stem. Refer to **Instrument Cluster Components - Trip Odometer Reset Knob** in the Removal and Installation section of this group for the procedures.

(7) Reconnect the battery negative cable.

## INSTRUMENT PANEL CENTER UPPER BEZEL

**WARNING: ON VEHICLES EQUIPPED WITH AIR-BAGS, REFER TO GROUP 8M - PASSIVE RESTRAINT SYSTEMS BEFORE ATTEMPTING ANY STEERING WHEEL, STEERING COLUMN, OR INSTRUMENT PANEL COMPONENT DIAGNOSIS OR SERVICE. FAILURE TO TAKE THE PROPER PRECAUTIONS COULD RESULT IN ACCIDENTAL AIR-BAG DEPLOYMENT AND POSSIBLE PERSONAL INJURY.**

## REMOVAL

(1) Disconnect and isolate the battery negative cable.

## REMOVAL AND INSTALLATION (Continued)

(2) Using a trim stick or another suitable wide flat-bladed tool, gently pry each of the four corners of the center upper bezel away from the instrument panel far enough to disengage the four snap clips from their receptacles (Fig. 14).

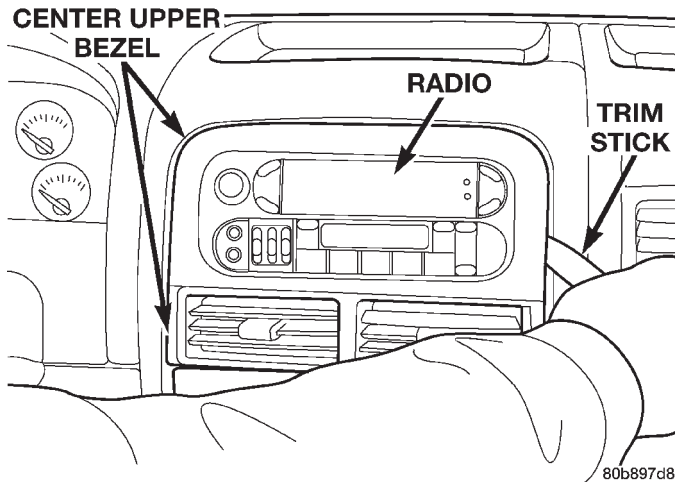

**Fig. 14 Instrument Panel Center Upper Bezel Remove/Install**

(3) Remove the center upper bezel from the instrument panel.

**INSTALLATION**

- (1) Position the center upper bezel to the instrument panel.
- (2) Align the four snap clips on the center upper bezel with the receptacles in the instrument panel top pad.
- (3) Press firmly on the center upper bezel over each of the snap clip locations until each of the snap clips is fully engaged in its receptacle.
- (4) Reconnect the battery negative cable.

**INSTRUMENT PANEL CENTER LOWER BEZEL**

**WARNING: ON VEHICLES EQUIPPED WITH AIR-BAGS, REFER TO GROUP 8M - PASSIVE RESTRAINT SYSTEMS BEFORE ATTEMPTING ANY STEERING WHEEL, STEERING COLUMN, OR INSTRUMENT PANEL COMPONENT DIAGNOSIS OR SERVICE. FAILURE TO TAKE THE PROPER PRECAUTIONS COULD RESULT IN ACCIDENTAL AIR-BAG DEPLOYMENT AND POSSIBLE PERSONAL INJURY.**

**REMOVAL**

- (1) Disconnect and isolate the battery negative cable.
- (2) Using a trim stick or another suitable wide flat-bladed tool, gently pry each of the four corners of the center lower bezel away from the instrument

panel far enough to disengage the four snap clips from their receptacles (Fig. 15).

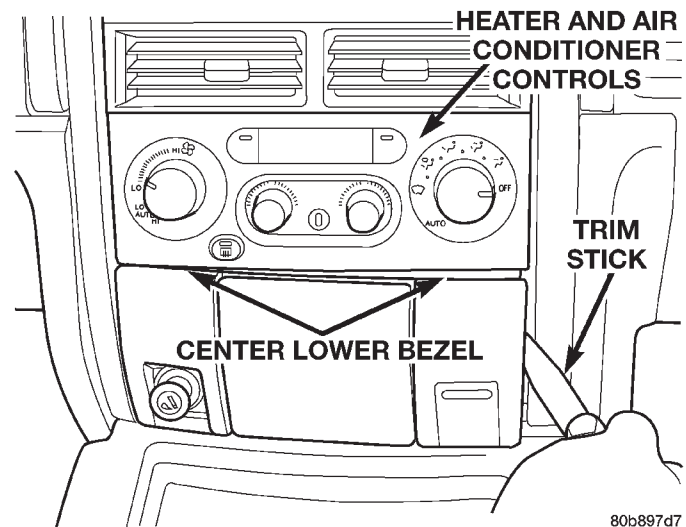

**Fig. 15 Instrument Panel Center Lower Bezel Remove/Install**

- (3) Pull the center lower bezel away from the instrument panel far enough to access the instrument panel wire harness connectors.
- (4) Squeeze the mounting legs of the ash receiver lamp hood and remove it from the rectangular hole in the ash receiver flame shield.
- (5) If the vehicle is so equipped, disconnect the instrument panel wire harness connectors from the connector receptacles of the two heated seat switches.
- (6) Disconnect the instrument panel wire harness connectors from the connector receptacles of the cigar lighter and the accessory power outlet.
- (7) Remove the center lower bezel from the instrument panel.

**INSTALLATION**

- (1) Position the center lower bezel to the instrument panel.
- (2) Reconnect the instrument panel wire harness connectors to the connector receptacles of the cigar lighter and the accessory power outlet.
- (3) If the vehicle is so equipped, reconnect the instrument panel wire harness connectors to the connector receptacles of the two heated seat switches.
- (4) Squeeze the mounting legs of the ash receiver lamp hood and install it into the rectangular hole in the ash receiver flame shield.
- (5) Align the two lower snap clips on the center lower bezel with the receptacles in the instrument panel top pad.
- (6) Press firmly on the center lower bezel over each of the lower snap clip locations until each of the snap clips is fully engaged in its receptacle.

## REMOVAL AND INSTALLATION (Continued)

(7) Align the two upper snap clips on the center lower bezel with the receptacles in the instrument panel top pad.

(8) Press firmly on the center lower bezel over each of the upper snap clip locations until each of the snap clips is fully engaged in its receptacle.

(9) Reconnect the battery negative cable.

## INSTRUMENT PANEL CIGAR LIGHTER AND POWER OUTLET

**WARNING: ON VEHICLES EQUIPPED WITH AIRBAGS, REFER TO GROUP 8M - PASSIVE RESTRAINT SYSTEMS BEFORE ATTEMPTING ANY STEERING WHEEL, STEERING COLUMN, OR INSTRUMENT PANEL COMPONENT DIAGNOSIS OR SERVICE. FAILURE TO TAKE THE PROPER PRECAUTIONS COULD RESULT IN ACCIDENTAL AIRBAG DEPLOYMENT AND POSSIBLE PERSONAL INJURY.**

## REMOVAL

(1) Disconnect and isolate the battery negative cable.

(2) Remove the center lower bezel from the instrument panel. Refer to **Instrument Panel Center Lower Bezel** in the Removal and Installation section of this group for the procedures.

(3) Pull the cigar lighter knob and element or the protective cap out of the cigar lighter receptacle base, or open the power outlet door in the instrument panel center lower bezel.

(4) Look inside the cigar lighter or power outlet receptacle base and note the position of the rectangular retaining bosses of the mount that secures the receptacle base to the instrument panel center lower bezel (Fig. 16).

(5) Insert a pair of external snap ring pliers into the cigar lighter or power outlet receptacle base and engage the tips of the pliers with the retaining bosses of the mount.

(6) Squeeze the pliers to disengage the mount retaining bosses from the receptacle base and, using a gentle rocking motion, pull the pliers and the receptacle base out of the mount.

(7) Remove the cigar lighter or power outlet mount from the instrument panel center lower bezel.

## INSTALLATION

(1) Install the cigar lighter or power outlet mount into the instrument panel center lower bezel.

(2) Align the splines on the outside of the cigar lighter or power outlet receptacle base connector receptacle with the grooves on the inside of the mount.

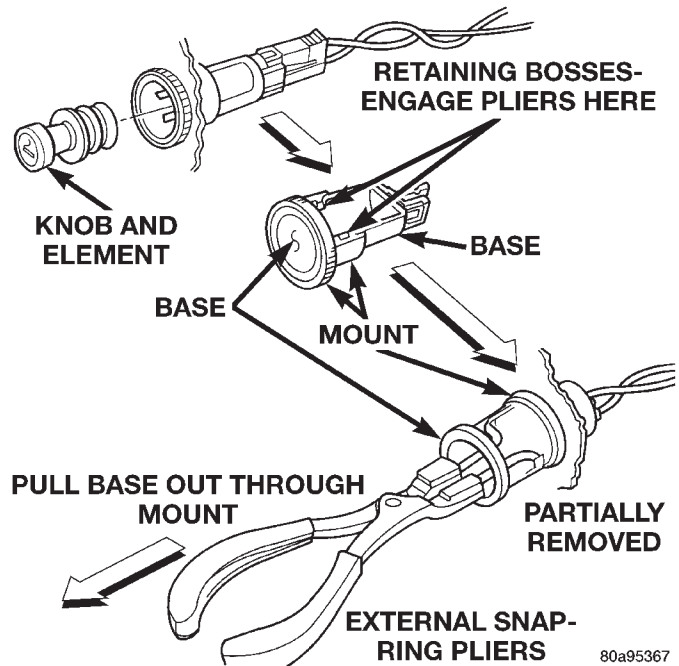

*Fig. 16 Cigar Lighter and Power Outlet Remove/ Install - Typical*

(3) Press firmly on the cigar lighter or power outlet receptacle base until the retaining bosses of the mount are fully engaged in their receptacles.

(4) Install the cigar lighter knob and element or the protective cap into the cigar lighter receptacle base, or close the power outlet door in the instrument panel center lower bezel.

(5) Install the center lower bezel onto the instrument panel. Refer to **Instrument Panel Center Lower Bezel** in the Removal and Installation section of this group for the procedures.

(6) Reconnect the battery negative cable.

## CIGAR LIGHTER RELAY

**WARNING: ON VEHICLES EQUIPPED WITH AIRBAGS, REFER TO GROUP 8M - PASSIVE RESTRAINT SYSTEMS BEFORE ATTEMPTING ANY STEERING WHEEL, STEERING COLUMN, OR INSTRUMENT PANEL COMPONENT DIAGNOSIS OR SERVICE. FAILURE TO TAKE THE PROPER PRECAUTIONS COULD RESULT IN ACCIDENTAL AIRBAG DEPLOYMENT AND POSSIBLE PERSONAL INJURY.**

## REMOVAL

(1) Disconnect and isolate the battery negative cable.

(2) Remove the steering column opening cover from the instrument panel. Refer to **Steering Column Opening Cover** in the Removal and Installa-

## REMOVAL AND INSTALLATION (Continued)

tion section of Group 8E - Instrument Panel Systems for the procedures.

(3) The cigar lighter relay is located on the left side of the combination flasher in the junction block (Fig. 17).

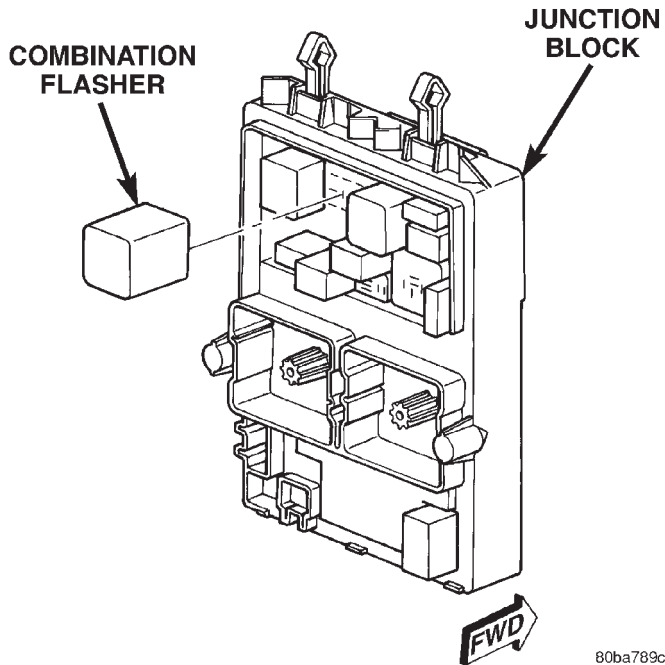

**Fig. 17 Junction Block**

(4) Remove the cigar lighter relay from the junction block.

## INSTALLATION

(1) Position the cigar lighter relay in the proper receptacle in the junction block.

(2) Align the cigar lighter relay terminals with the terminal cavities in the junction block receptacle.

(3) Push in firmly on the cigar lighter relay until the terminals are fully seated in the terminal cavities in the junction block receptacle.

(4) Install the steering column opening cover onto the instrument panel. Refer to **Steering Column Opening Cover** in the Removal and Installation section of Group 8E - Instrument Panel Systems for the procedures.

(5) Reconnect the battery negative cable.

## INSTRUMENT PANEL POWER OUTLET DOOR

**WARNING: ON VEHICLES EQUIPPED WITH AIRBAGS, REFER TO GROUP 8M - PASSIVE RESTRAINT SYSTEMS BEFORE ATTEMPTING ANY STEERING WHEEL, STEERING COLUMN, OR INSTRUMENT PANEL COMPONENT DIAGNOSIS OR SERVICE. FAILURE TO TAKE THE PROPER PRECAUTIONS COULD RESULT IN ACCIDENTAL AIR-**

**BAG DEPLOYMENT AND POSSIBLE PERSONAL INJURY.**

## REMOVAL

(1) Disconnect and isolate the battery negative cable.

(2) Remove the center lower bezel from the instrument panel. Refer to **Instrument Panel Center Lower Bezel** in the Removal and Installation section of this group for the procedures.

(3) With the power outlet door in the open position, carefully spread the power outlet door hinge arms far enough to disengage the pivot pins from the pivots on the back side of the center lower bezel (Fig. 18).

**NOTE:** The power outlet door is more easily serviced while in the open position. The illustration shows the door in the closed position for additional visibility of the assist spring orientation and anchor point details.

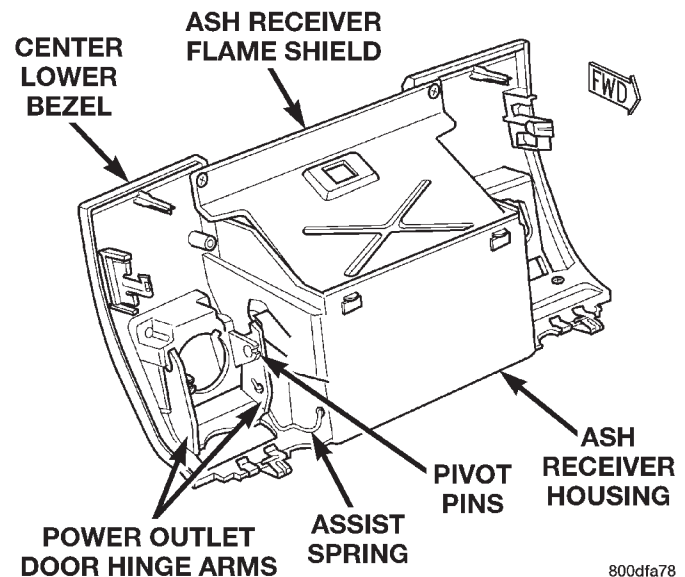

**Fig. 18 Instrument Panel Power Outlet Door Remove/Install**

(4) Disengage the stepped ends of the assist spring from the anchor holes in the inboard power outlet door hinge arm and in the side of the ash receiver housing.

(5) Remove the power outlet door from the instrument panel center lower bezel.

## INSTALLATION

(1) Position the power outlet door to the instrument panel center lower bezel.

(2) Engage the stepped ends of the assist spring with the anchor holes in the inboard power outlet

## REMOVAL AND INSTALLATION (Continued)

door hinge arm and in the side of the ash receiver housing.

(3) With the power outlet door in the open position, carefully spread the power outlet door hinge arms far enough to engage the pivot pins with the pivots on the back side of the lower center bezel.

(4) Install the center lower bezel into the instrument panel. Refer to **Instrument Panel Center Lower Bezel** in the Removal and Installation section of this group for the procedures.

(5) Reconnect the battery negative cable.

## INSTRUMENT PANEL TO CENTER FLOOR TUNNEL BRACKET

**WARNING: ON VEHICLES EQUIPPED WITH AIR-BAGS, REFER TO GROUP 8M - PASSIVE RESTRAINT SYSTEMS BEFORE ATTEMPTING ANY STEERING WHEEL, STEERING COLUMN, OR INSTRUMENT PANEL COMPONENT DIAGNOSIS OR SERVICE. FAILURE TO TAKE THE PROPER PRECAUTIONS COULD RESULT IN ACCIDENTAL AIR-BAG DEPLOYMENT AND POSSIBLE PERSONAL INJURY.**

## REMOVAL

(1) Disconnect and isolate the battery negative cable.

(2) Remove the front bin from the floor console. Refer to **Floor Console** in the Removal and Installation section of Group 23 - Body for the procedures.

(3) Reach through the front bin opening of the floor console to access and disengage the instrument panel wire harness retainer from the mounting hole on the driver side of the instrument panel to center floor tunnel bracket.

(4) Remove the two screws that secure the instrument panel to center floor tunnel bracket to the instrument panel (Fig. 19).

(5) Remove the two nuts that secure the instrument panel to center floor tunnel bracket to the studs on the floor panel transmission tunnel.

(6) Remove the center floor tunnel bracket from the instrument panel and the floor panel transmission tunnel studs.

## INSTALLATION

(1) Position the instrument panel to center floor tunnel bracket over the floor panel transmission tunnel studs and slide it up against the instrument panel.

(2) Install and tighten the two nuts that secure the instrument panel to center floor tunnel bracket to the studs on the floor panel transmission tunnel. Tighten the nuts to 11.3 N·m (100 in. lbs.).

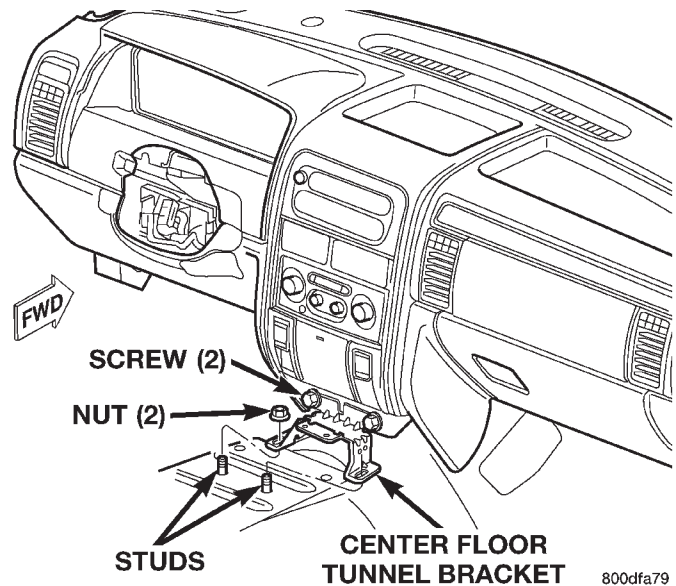

**Fig. 19 Instrument Panel to Center Floor Tunnel Bracket Remove/Install**

(3) Install and tighten the two screws that secure the instrument panel to center floor tunnel bracket to the instrument panel. Tighten the screws to 11.3 N·m (100 in. lbs.).

(4) Reach through the front bin opening of the floor console to access and engage the instrument panel wire harness retainer with the mounting hole on the driver side of the instrument panel to center floor tunnel bracket.

(5) Install the front bin into the floor console. Refer to **Floor Console** in the Removal and Installation section of Group 23 - Body for the procedures.

(6) Reconnect the battery negative cable.

## GLOVE BOX

The glove box on this model can be rolled down beyond the stop bumpers in order to access many components for service, without complete glove box removal. Refer to Roll Down for this procedure. The glove box can also be removed from the instrument panel completely. Refer to Removal for this procedure.

**WARNING: ON VEHICLES EQUIPPED WITH AIR-BAGS, REFER TO GROUP 8M - PASSIVE RESTRAINT SYSTEMS BEFORE ATTEMPTING ANY STEERING WHEEL, STEERING COLUMN, OR INSTRUMENT PANEL COMPONENT DIAGNOSIS OR SERVICE. FAILURE TO TAKE THE PROPER PRECAUTIONS COULD RESULT IN ACCIDENTAL AIR-BAG DEPLOYMENT AND POSSIBLE PERSONAL INJURY.**

## REMOVAL AND INSTALLATION (Continued)

## ROLL DOWN

(1) Disconnect and isolate the battery negative cable.

(2) Open the glove box until the integral stops on the back edge of the glove box bin are resting against the rubber stop bumpers in the upper glove box opening reinforcement.

(3) Reach into the glove box and with the middle finger of each hand, deflect the rubber flap of the two glove box stop bumpers on the upper glove box opening reinforcement toward the front of the vehicle.

(4) With the glove box stop bumpers deflected, roll the glove box door downward until the integral stops on the back edge of the glove box bin pass through the rubber stop bumper openings in the upper glove box opening reinforcement (Fig. 20).

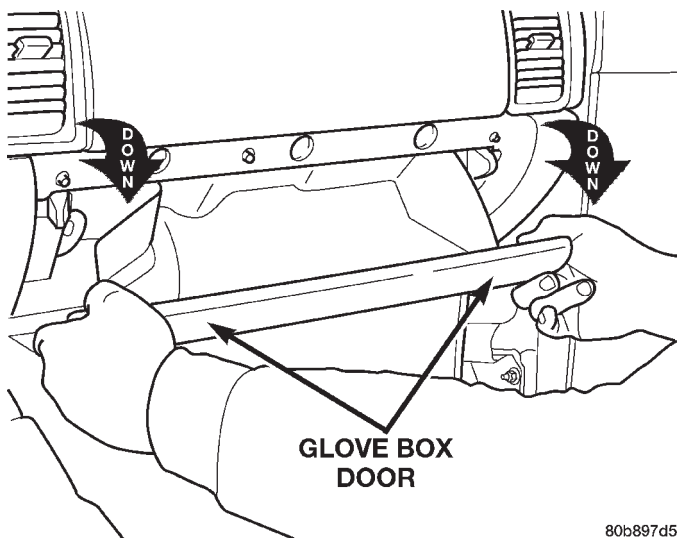

Fig. 20 Glove Box Roll Down

(5) The rubber stop bumpers will be deflected automatically by the integral stops on the back of the glove box when the glove box is rolled back up into the instrument panel.

## REMOVAL

(1) Disconnect and isolate the battery negative cable.

(2) Roll the glove box down from the instrument panel. Refer to **Glove Box - Roll Down** in the Removal and Installation section of this group for the procedures.

**NOTE:** Be certain to use care not to damage or remove the glove box hinge bumpers on the lower instrument panel glove box opening reinforcement when removing the glove box from the instrument panel.

(3) Firmly grip both ends of the glove box door, then twist and pull the door as necessary to disengage the inboard hinge hook from the inboard hinge pin on the instrument panel and reorient the hook to the underside of the hinge pin (Fig. 21).

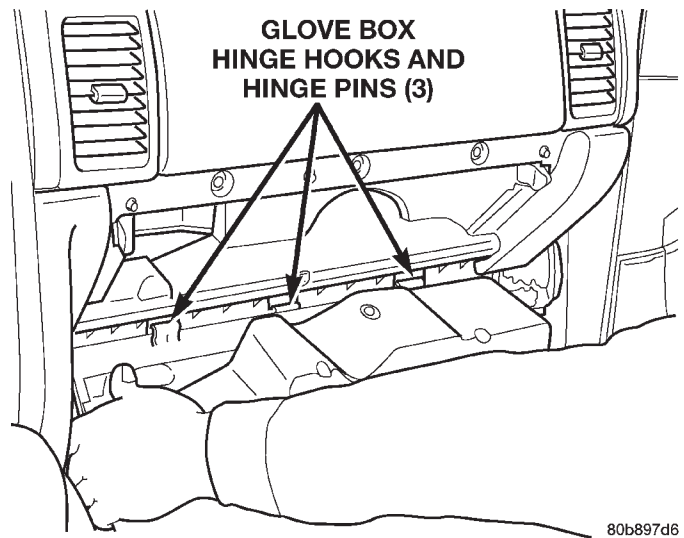

Fig. 21 Glove Box Remove/Install

(4) Raise the glove box door until it is perpendicular to the instrument panel.

(5) Twist the door slightly in the counterclockwise direction and use a jiggling action to disengage the remaining two hinge hooks from their respective hinge pins on the instrument panel.

(6) Remove the glove box from the instrument panel.

## INSTALLATION

**NOTE:** Be certain to use care not to damage or remove the glove box hinge bumpers on the lower instrument panel glove box opening reinforcement when installing the glove box onto the instrument panel.

(1) Position the glove box to the instrument panel with the outboard hinge hook oriented over the outboard hinge pin and the center hinge hook oriented under the center hinge pin.

(2) Raise the glove box door until it is perpendicular to the instrument panel.

(3) Firmly grip both ends of the glove box door and twist the door slightly in the clockwise direction to engage the inboard glove box hinge hook over the inboard hinge pin on the instrument panel.

(4) Roll the glove box back up into the instrument panel. Refer to **Glove Box - Roll Down** in the Removal and Installation section of this group for the procedures.

(5) Reconnect the battery negative cable.



REMOVAL AND INSTALLATION (Continued)

**GLOVE BOX LATCH**

**WARNING: ON VEHICLES EQUIPPED WITH AIR-BAGS, REFER TO GROUP 8M - PASSIVE RESTRAINT SYSTEMS BEFORE ATTEMPTING ANY STEERING WHEEL, STEERING COLUMN, OR INSTRUMENT PANEL COMPONENT DIAGNOSIS OR SERVICE. FAILURE TO TAKE THE PROPER PRECAUTIONS COULD RESULT IN ACCIDENTAL AIR-BAG DEPLOYMENT AND POSSIBLE PERSONAL INJURY.**

**REMOVAL**

- (1) Disconnect and isolate the battery negative cable.
- (2) Roll down the glove box from the instrument panel. Refer to **Glove Box - Roll Down** in the Removal and Installation section of this group for the procedures.
- (3) Remove the three screws that secure the glove box latch to the inner glove box door (Fig. 22).

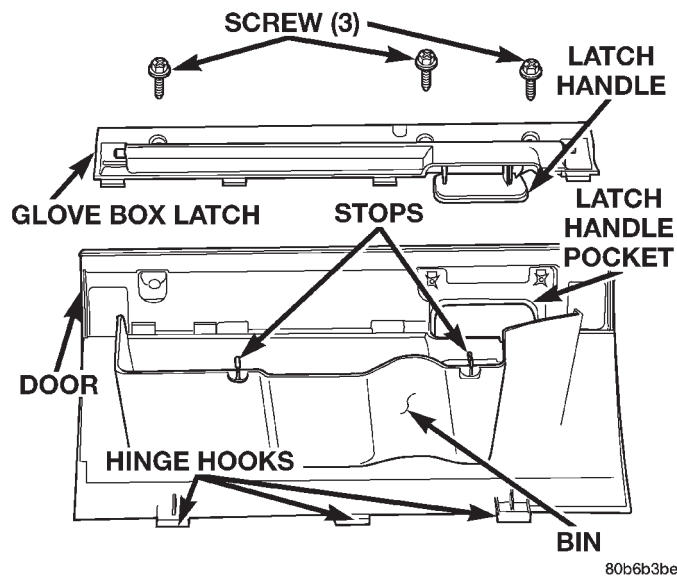

**Fig. 22 Glove Box Latch Remove/Install**

- (4) Lift up on the latch handle on the outer glove box door far enough to loosen the latch assembly on the inner glove box door.
- (5) Remove the latch unit from the inner glove box door.

**INSTALLATION**

- (1) Position the latch unit to the inner glove box door.
- (2) Guide the latch handle into the latch handle pocket on the outer glove box door.
- (3) Install and tighten the three screws that secure the glove box latch to the inner glove box door. Tighten the screws to 2.2 N·m (20 in. lbs.).

- (4) Roll the glove box back up into the instrument panel. Refer to **Glove Box - Roll Down** in the Removal and Installation section of this group for the procedures.
- (5) Reconnect the battery negative cable.

**INSTRUMENT PANEL END CAP**

**WARNING: ON VEHICLES EQUIPPED WITH AIR-BAGS, REFER TO GROUP 8M - PASSIVE RESTRAINT SYSTEMS BEFORE ATTEMPTING ANY STEERING WHEEL, STEERING COLUMN, OR INSTRUMENT PANEL COMPONENT DIAGNOSIS OR SERVICE. FAILURE TO TAKE THE PROPER PRECAUTIONS COULD RESULT IN ACCIDENTAL AIR-BAG DEPLOYMENT AND POSSIBLE PERSONAL INJURY.**

**REMOVAL**

- (1) Disconnect and isolate the battery negative cable.
- (2) Open the glove box.
- (3) Remove the one screw that secures the out-board end of the end cap to the instrument panel top pad (Fig. 23).

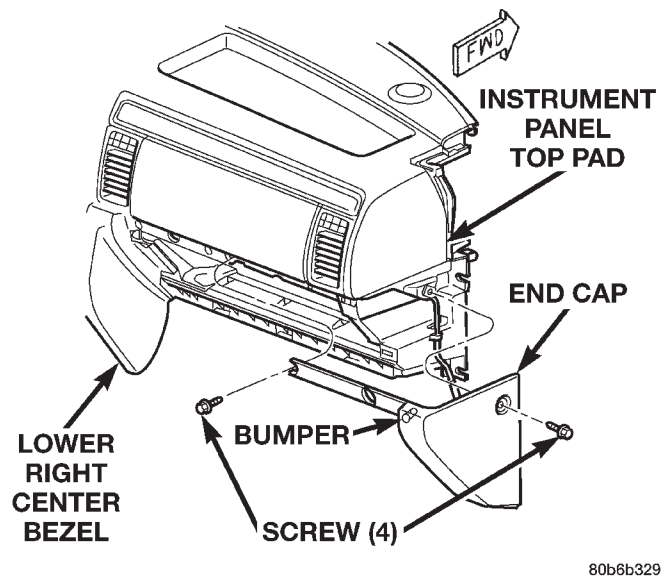

**Fig. 23 Instrument Panel End Cap Remove/Install**

- (4) Remove the three screws that secure the end cap to the instrument panel glove box opening.
- (5) Pull the end cap straight back from the instrument panel to disengage the one snap clip that secures it to the receptacle in the instrument panel structural duct.
- (6) Remove the end cap from the instrument panel.

## REMOVAL AND INSTALLATION (Continued)

## INSTALLATION

(1) Be certain that the glove box catch bumper is installed in the mounting hole nearest the outboard end of the end cap extension over the instrument panel upper glove box opening reinforcement.

(2) Position the end cap to the instrument panel. Be certain that the end of the end cap extension near the center of the upper glove box opening reinforcement is positioned underneath the end of the extension from the lower right center bezel.

(3) Align the snap clip on the end cap with the receptacle on the instrument panel structural duct.

(4) Press firmly on the instrument panel end cap over the snap clip location until the snap clip is fully engaged in its receptacle.

(5) Install and tighten the three screws that secure the end cap to the instrument panel glove box opening. Tighten the screws to 2.2 N·m (20 in. lbs.).

(6) Install and tighten the one screw that secures the outboard end of the end cap to the instrument panel top pad. Tighten the screw to 2.2 N·m (20 in. lbs.).

(7) Close the glove box.

(8) Reconnect the battery negative cable.

## INSTRUMENT PANEL LOWER RIGHT CENTER BEZEL

**WARNING: ON VEHICLES EQUIPPED WITH AIR-BAGS, REFER TO GROUP 8M - PASSIVE RESTRAINT SYSTEMS BEFORE ATTEMPTING ANY STEERING WHEEL, STEERING COLUMN, OR INSTRUMENT PANEL COMPONENT DIAGNOSIS OR SERVICE. FAILURE TO TAKE THE PROPER PRECAUTIONS COULD RESULT IN ACCIDENTAL AIR-BAG DEPLOYMENT AND POSSIBLE PERSONAL INJURY.**

## REMOVAL

(1) Disconnect and isolate the battery negative cable.

(2) Open the glove box.

(3) Remove the three screws that secure the lower right center bezel to the instrument panel glove box opening (Fig. 24).

(4) Pull the lower right center bezel straight back from the instrument panel to disengage the two snap clips that secure it to the receptacles in the instrument panel top pad.

(5) Remove the lower right center bezel from the instrument panel.

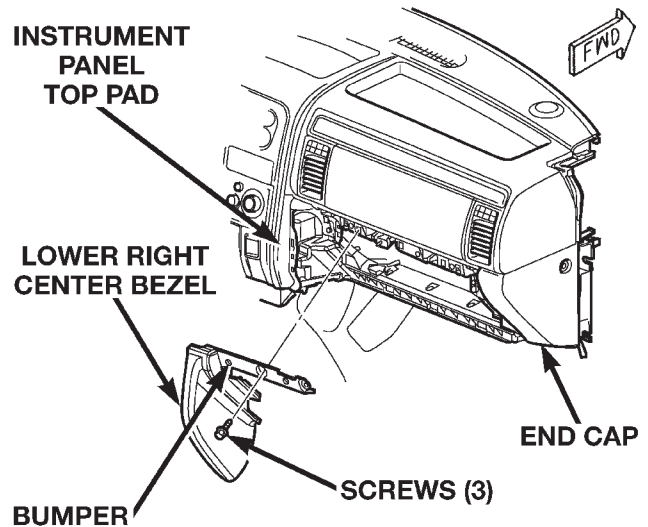

80b6b32c

**Fig. 24 Instrument Panel Lower Right Center Bezel Remove/Install**

## INSTALLATION

(1) Be certain that the glove box catch bumper is installed in the mounting hole nearest the inboard end of the lower right center bezel extension over the instrument panel upper glove box opening reinforcement.

(2) Position the lower right center bezel to the instrument panel. Be certain that the end of the lower right center bezel extension near the center of the upper glove box opening reinforcement is positioned on top of the end of the extension from the end cap.

(3) Align the snap clips on the lower right center bezel with the receptacles in the instrument panel top pad.

(4) Press firmly on the lower right center bezel over each of the snap clip locations until the snap clips are fully engaged in their receptacles.

(5) Install and tighten the three screws that secure the lower right center bezel to the instrument panel glove box opening. Tighten the screws to 2.2 N·m (20 in. lbs.).

(6) Close the glove box.

(7) Reconnect the battery negative cable.

## GLOVE BOX LATCH STRIKER

**WARNING: ON VEHICLES EQUIPPED WITH AIR-BAGS, REFER TO GROUP 8M - PASSIVE RESTRAINT SYSTEMS BEFORE ATTEMPTING ANY STEERING WHEEL, STEERING COLUMN, OR INSTRUMENT PANEL COMPONENT DIAGNOSIS OR SERVICE. FAILURE TO TAKE THE PROPER PRECAUTIONS COULD RESULT IN ACCIDENTAL AIR-BAG DEPLOYMENT AND POSSIBLE PERSONAL INJURY.**

## REMOVAL AND INSTALLATION (Continued)

## REMOVAL

(1) Disconnect and isolate the battery negative cable.

(2) If the inboard glove box latch striker is being serviced, remove the lower right center bezel from the instrument panel. Refer to **Instrument Panel Lower Right Center Bezel** in the Removal and Installation section of this group for the procedures. If the outboard glove box latch striker is being serviced, remove the end cap from the instrument panel. Refer to **Instrument Panel End Cap** in the Removal and Installation section of this group for the procedures.

(3) Remove the one screw that secures the upper mounting flange of the glove box latch striker to the instrument panel structural duct at either side of the glove box opening (Fig. 25).

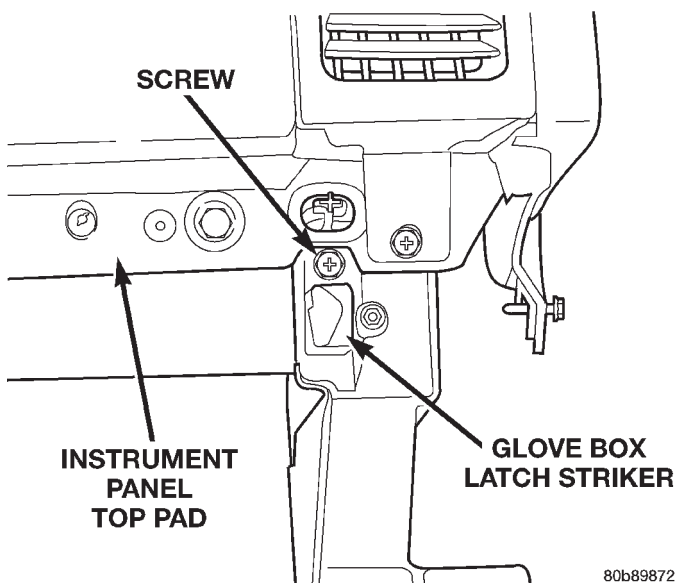

**Fig. 25 Glove Box Latch Striker Remove/Install**

(4) Pull the upper mounting flange of the glove box latch striker downward to disengage the hook formation on the lower end of the striker from the mounting hole in the instrument panel structural duct.

(5) Remove the glove box latch striker from the instrument panel.

## INSTALLATION

(1) Position the glove box latch striker to the instrument panel.

(2) Engage the hook formation on the lower end of the glove box latch striker in the mounting hole in the instrument panel structural duct.

(3) Roll the upper mounting flange of the glove box latch striker upward until it is flush with the instrument panel structural duct on either side of the glove box opening.

(4) Install and tighten the screw that secures the upper mounting flange of the glove box latch striker to the instrument panel structural duct. Tighten the screw to 2.2 N·m (20 in. lbs.).

(5) If the inboard glove box latch striker was serviced, install the lower right center bezel onto the instrument panel. Refer to **Instrument Panel Lower Right Center Bezel** in the Removal and Installation section of this group for the procedures. If the outboard glove box latch striker was serviced, install the end cap onto the instrument panel. Refer to **Instrument Panel End Cap** in the Removal and Installation section of this group for the procedures.

(6) Reconnect the battery negative cable.

## GLOVE BOX LAMP AND SWITCH

**WARNING: ON VEHICLES EQUIPPED WITH AIRBAGS, REFER TO GROUP 8M - PASSIVE RESTRAINT SYSTEMS BEFORE ATTEMPTING ANY STEERING WHEEL, STEERING COLUMN, OR INSTRUMENT PANEL COMPONENT DIAGNOSIS OR SERVICE. FAILURE TO TAKE THE PROPER PRECAUTIONS COULD RESULT IN ACCIDENTAL AIRBAG DEPLOYMENT AND POSSIBLE PERSONAL INJURY.**

## REMOVAL

(1) Disconnect and isolate the battery negative cable.

(2) Roll down the glove box from the instrument panel. Refer to **Glove Box - Roll Down** in the Removal and Installation section of this group for the procedures.

(3) Remove the lower right center bezel from the instrument panel. Refer to **Instrument Panel Lower Right Center Bezel** in the Removal and Installation section of this group for the procedures.

(4) Reach through the glove box opening and behind the glove box opening upper reinforcement in the instrument panel to access and depress the retaining latches on the top and bottom of the glove box lamp and switch housing.

(5) While holding the retaining latches depressed, push the glove box lamp and switch out through the mounting hole in the instrument panel glove box opening upper reinforcement (Fig. 26).

(6) Pull the glove box lamp and switch out from the mounting hole far enough to access the wire harness connector.

(7) Disconnect the instrument panel wire harness connector from the glove box lamp and switch connector receptacle.

(8) Remove the glove box lamp and switch from the instrument panel.

## REMOVAL AND INSTALLATION (Continued)

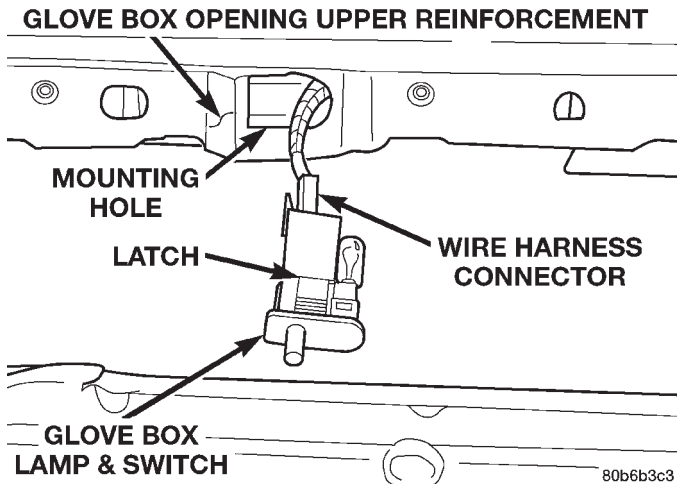

**Fig. 26 Glove Box Lamp and Switch Remove/Install**

## INSTALLATION

- (1) Position the glove box lamp and switch to the instrument panel.
- (2) Reconnect the instrument panel wire harness connector to the glove box lamp and switch receptacle.
- (3) Feed the instrument panel wire harness back into the glove box lamp and switch mounting hole in the glove box opening upper reinforcement.
- (4) Align the glove box lamp and switch housing with the mounting hole in the instrument panel glove box opening upper reinforcement.
- (5) Push the glove box lamp and switch into the mounting hole in the instrument panel glove box opening upper reinforcement until the retaining latches are fully engaged.
- (6) Install the lower right center bezel onto the instrument panel. Refer to **Instrument Panel Lower Right Center Bezel** in the Removal and Installation section of this group for the procedures.
- (7) Roll the glove box back up into the instrument panel. Refer to **Glove Box - Roll Down** in the Removal and Installation section of this group for the procedures.
- (8) Reconnect the battery negative cable.

## INSTRUMENT PANEL TOP COVER

**WARNING: ON VEHICLES EQUIPPED WITH AIR-BAGS, REFER TO GROUP 8M - PASSIVE RESTRAINT SYSTEMS BEFORE ATTEMPTING ANY STEERING WHEEL, STEERING COLUMN, OR INSTRUMENT PANEL COMPONENT DIAGNOSIS OR SERVICE. FAILURE TO TAKE THE PROPER PRECAUTIONS COULD RESULT IN ACCIDENTAL AIR-BAG DEPLOYMENT AND POSSIBLE PERSONAL INJURY.**

## REMOVAL

- (1) Disconnect and isolate the battery negative cable.
- (2) Using a trim stick or another suitable wide flat-bladed tool, gently pry the rear edge (farthest from the windshield) of the top cover up and away from the instrument panel far enough to disengage the four snap clip retainers from their receptacles in the instrument panel top pad (Fig. 27).

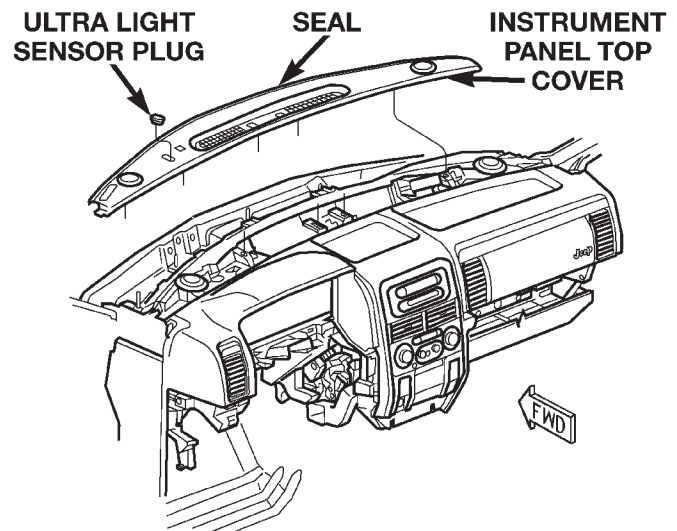

**Fig. 27 Instrument Panel Top Cover Remove/Install**

- (3) Remove the top cover from the instrument panel.

## INSTALLATION

- (1) If the vehicle is not equipped with the optional ultra light sensor, be certain that the ultra light sensor plug is installed in the hole to the left of the driver side defroster outlet in the instrument panel top cover.
- (2) Before installing the top cover to the instrument panel top pad, be certain that the rubber top cover seal is properly positioned on the forward edge of the top cover panel.
- (3) Position the top cover on the instrument panel top pad.
- (4) Align the four snap clips on the top cover with the snap clip receptacles in the instrument panel top pad.
- (5) Press firmly downward on the top cover over each of the four snap clip locations until each of the snap clips is fully seated in their receptacles in the instrument panel top pad.
- (6) Reconnect the battery negative cable.

## REMOVAL AND INSTALLATION (Continued)

## INSTRUMENT PANEL TOP PAD

**WARNING: ON VEHICLES EQUIPPED WITH AIR-BAGS, REFER TO GROUP 8M - PASSIVE RESTRAINT SYSTEMS BEFORE ATTEMPTING ANY STEERING WHEEL, STEERING COLUMN, OR INSTRUMENT PANEL COMPONENT DIAGNOSIS OR SERVICE. FAILURE TO TAKE THE PROPER PRECAUTIONS COULD RESULT IN ACCIDENTAL AIR-BAG DEPLOYMENT AND POSSIBLE PERSONAL INJURY.**

## REMOVAL

(1) Disconnect and isolate the battery negative cable.

(2) Remove the trim from the right and left A-pillars. Refer to **A-Pillar Trim** in the Removal and Installation section of Group 23 - Body for the procedures.

(3) Remove the top cover from the instrument panel. Refer to **Instrument Panel Top Cover** in the Removal and Installation section of this group for the procedures.

(4) Remove the four nuts that secure the instrument panel top pad to the studs on the dash panel near the windshield fence line (Fig. 28).

(5) If the vehicle is so equipped, remove the speakers from the instrument panel top pad. Refer to **Instrument Panel Speakers** in the Removal and Installation section of Group 8F - Audio Systems for the procedures.

(6) If the vehicle is so equipped, disengage the retainer that secures each of the two instrument panel wire harness speaker takeouts to the mounting hole in the instrument panel top pad. Tuck the loose ends of the wire harness speaker takeouts down the defroster ducts to keep them out of the way for the remainder of the procedure.

(7) If the vehicle is so equipped, remove the two screws that secure the security set lamp/ultra light sensor unit to the instrument panel top pad just outboard of the left defroster outlet. Move the security set lamp/ultra light sensor unit towards the windshield to keep it out of the way for the remainder of the procedure.

(8) Remove the cluster bezel from the instrument panel. Refer to **Cluster Bezel** in the Removal and Installation section of this group for the procedures.

(9) Remove the instrument cluster from the instrument panel. Refer to **Instrument Cluster** in the Removal and Installation section of this group for the procedures.

(10) Remove the steering column opening cover from the instrument panel. Refer to **Steering Column Opening Cover** in the Removal and Installation section of this group for the procedures.

(11) Roll the glove box down from the instrument panel. Refer to **Glove Box - Roll Down** in the Removal and Installation section of this group for the procedures.

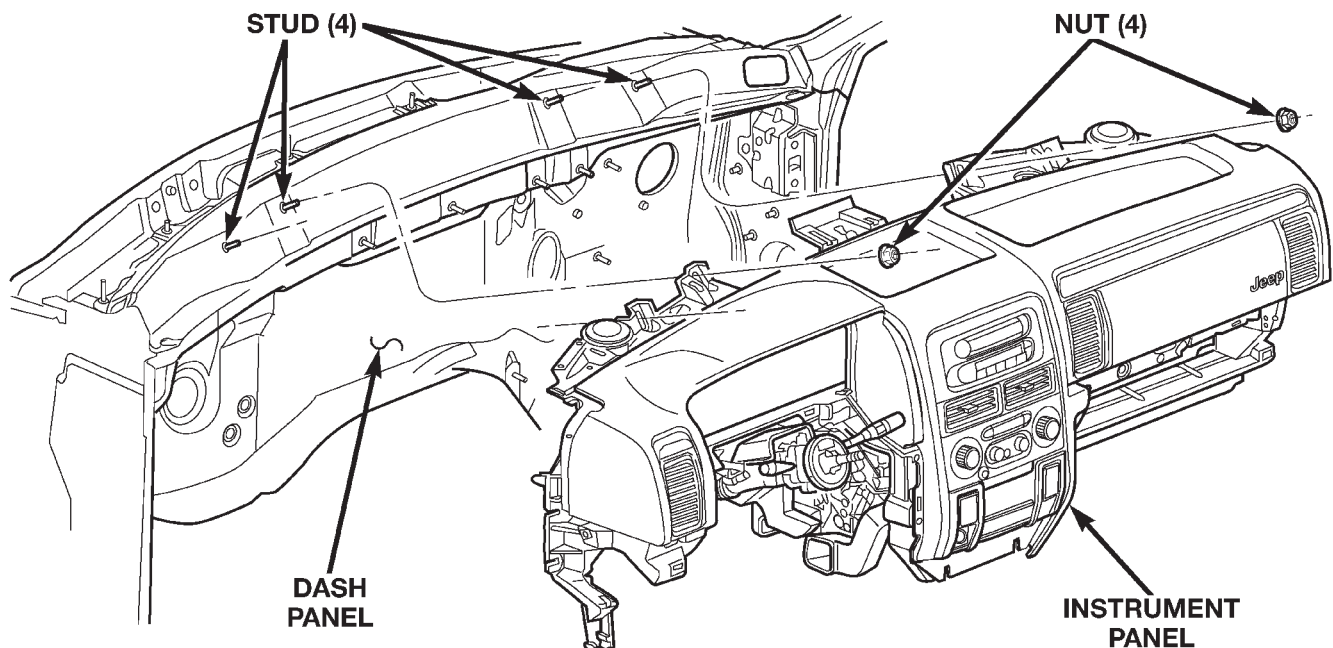

80b3c645

**Fig. 28 Instrument Panel Top Pad to Dash Panel Mounting**

## REMOVAL AND INSTALLATION (Continued)

(12) Remove the end cap from the passenger side lower outboard end of the instrument panel. Refer to **Instrument Panel End Cap** in the Removal and Installation section of this group for the procedures.

(13) Remove the lower right center bezel from the instrument panel. Refer to **Instrument Panel Lower Right Center Bezel** in the Removal and Installation section of this group for the procedures.

(14) Remove the glove box lamp and switch from the instrument panel. Refer to **Glove Box Lamp and Switch** in the Removal and Installation section of this group for the procedures.

(15) Remove the two large screws on the glove box opening upper reinforcement that secure the top pad to the instrument panel structural duct (Fig. 29).

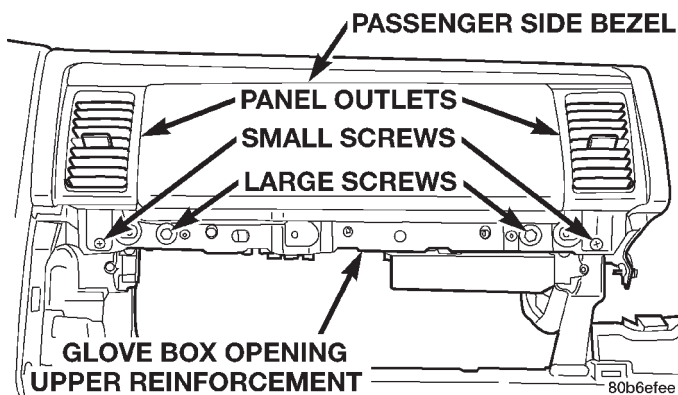

**Fig. 29 Instrument Panel Top Pad to Glove Box Opening Mounting**

(16) Remove the two small screws on the glove box opening upper reinforcement that secure the panel outlets to the instrument panel structural duct.

(17) Remove the center upper bezel from the instrument panel. Refer to **Instrument Panel Center Upper Bezel** in the Removal and Installation section of this group for the procedures.

(18) Remove the center lower bezel from the instrument panel. Refer to **Instrument Panel Center Lower Bezel** in the Removal and Installation section of this group for the procedures.

(19) Remove the four screws that secure the radio to the instrument panel structural support. Pull the radio out of the instrument panel far enough to access the screws that secure the top pad to the instrument panel structural duct.

(20) Remove the four screws that secure the heater-A/C control to the instrument panel structural duct. Pull the heater-A/C control out of the instrument panel far enough to access the screws that secure the top pad to the instrument panel structural duct.

(21) Remove all of the screws that secure the perimeter of the top pad to the instrument panel structural duct.

(22) Remove the front bin from the floor console. Refer to **Floor Console** in the Removal and Installation section of Group 23 - Body for the procedures.

(23) Reach through the front bin opening of the floor console to access and remove the two screws that secure the center floor tunnel bracket to the instrument panel.

(24) Reach through the front bin opening of the floor console to access and loosen the two nuts that secure the center floor tunnel bracket to the studs on the floor panel transmission tunnel.

(25) Slide the center floor tunnel bracket rearward in the vehicle far enough to disengage the locating hole in the lower flange of the top pad from the locating pin on the instrument panel structural duct (Fig. 30).

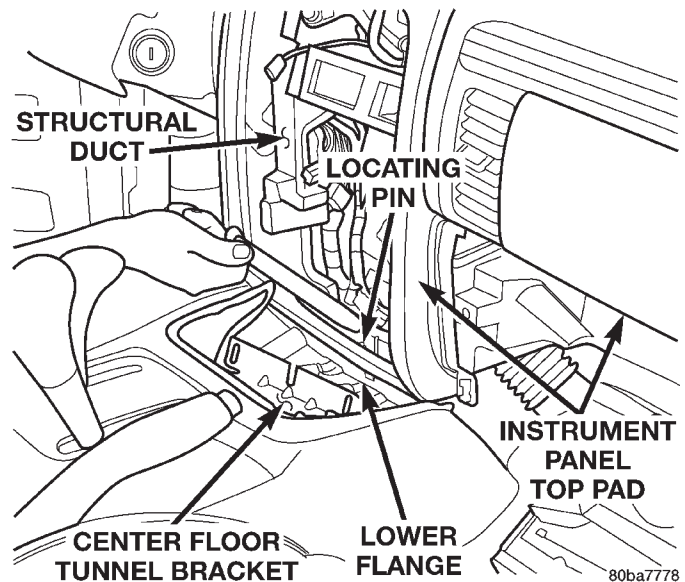

**Fig. 30 Instrument Panel Top Pad Remove/Install**

(26) Remove the instrument panel top pad from the instrument panel structural duct.

## INSTALLATION

If the top pad is being replaced with a new unit, be certain to transfer or install the panel outlets and the passenger side bezel to the new unit before it is installed on the instrument panel structural duct. Refer to **Ducts and Outlets** in the Removal and Installation section of Group 24 - Heating and Air Conditioning for the panel outlet service procedures. Refer to **Instrument Panel Passenger Side Bezel** in the Removal and Installation section of this group for the passenger side bezel service procedures.

(1) Position the instrument panel top pad over the instrument panel structural duct and the studs on the dash panel near the windshield fence line.

(2) Route the instrument panel wire harness take-out for the glove box lamp and switch unit to the

## REMOVAL AND INSTALLATION (Continued)

switch mounting hole in the upper glove box opening reinforcement.

(3) Reach through the front bin opening of the floor console to engage the locating hole in the lower flange of the top pad with the locating pin on the instrument panel structural duct.

(4) Reach through the front bin opening of the floor console to slide the center floor tunnel bracket forward in the vehicle far enough to capture the lower flange of the top pad between the bracket and the structural duct.

(5) Reach through the front bin opening of the floor console to install and tighten the two screws that secure the center floor tunnel bracket to the instrument panel. Tighten the screws to 11.8 N·m (105 in. lbs.).

(6) Reach through the front bin opening of the floor console to access and tighten the two nuts that secure the center floor tunnel bracket to the studs on the floor panel transmission tunnel. Tighten the nuts to 11.8 N·m (105 in. lbs.).

(7) Install the front bin into the floor console. Refer to **Floor Console** in the Removal and Installation section of Group 23 - Body for the procedures.

(8) Install and tighten all of the screws that secure the perimeter of the top pad to the instrument panel structural duct. Tighten the screws to 2.2 N·m (20 in. lbs.).

(9) Install and tighten the four screws that secure the heater-A/C control to the instrument panel structural support. Tighten the screws to 2.2 N·m (20 in. lbs.).

(10) Install and tighten the four screws that secure the radio to the instrument panel structural support. Tighten the screws to 2.2 N·m (20 in. lbs.).

(11) Install the center lower bezel onto the instrument panel. Refer to **Instrument Panel Center Lower Bezel** in the Removal and Installation section of this group for the procedures.

(12) Install the center upper bezel onto the instrument panel. Refer to **Instrument Panel Center Upper Bezel** in the Removal and Installation section of this group for the procedures.

(13) Install and tighten the two large screws on the glove box opening upper reinforcement that secure the top pad to the instrument panel structural duct. Tighten the screws to 11.8 N·m (105 in. lbs.).

(14) Install and tighten the two small screws on the glove box opening upper reinforcement that secure the panel outlets to the instrument panel structural duct. Tighten the screws to 2.2 N·m (20 in. lbs.).

(15) Install the glove box lamp and switch into the instrument panel. Refer to **Glove Box Lamp and Switch** in the Removal and Installation section of this group for the procedures.

(16) Install the lower right center bezel onto the instrument panel. Refer to **Instrument Panel Lower Right Center Bezel** in the Removal and Installation section of this group for the procedures.

(17) Install the end cap onto the instrument panel. Refer to **Instrument Panel End Cap** in the Removal and Installation section of this group for the procedures.

(18) Roll the glove box back up into the instrument panel. Refer to **Glove Box - Roll Down** in the Removal and Installation section of this group for the procedures.

(19) Install the steering column opening cover onto the instrument panel. Refer to **Steering Column Opening Cover** in the Removal and Installation section of this group for the procedures.

(20) Install the instrument cluster into the instrument panel. Refer to **Instrument Cluster** in the Removal and Installation section of this group for the procedures.

(21) Install the cluster bezel onto the instrument panel. Refer to **Cluster Bezel** in the Removal and Installation section of this group for the procedures.

(22) If the vehicle is so equipped, position the security set lamp/ultra light sensor unit to the instrument panel top pad just outboard of the left defroster outlet. Install and tighten the two screws that secure it there. Tighten the screws to 2.2 N·m (20 in. lbs.).

(23) If the vehicle is so equipped, engage the retainer that secures each of the two instrument panel wire harness speaker takeouts to the mounting hole in the instrument panel top pad.

(24) If the vehicle is so equipped, install the speakers onto the instrument panel top pad. Refer to **Instrument Panel Speakers** in the Removal and Installation section of Group 8F - Audio Systems for the procedures.

(25) Install and tighten the four nuts that secure the instrument panel top pad to the studs on the dash panel near the windshield fence line. Tighten the nuts to 11.8 N·m (105 in. lbs.).

(26) Install the top cover onto the instrument panel. Refer to **Instrument Panel Top Cover** in the Removal and Installation section of this group for the procedures.

(27) Install the trim onto the right and left A-pillars. Refer to **A-Pillar Trim** in the Removal and Installation section of Group 23 - Body for the procedures.

(28) Reconnect the battery negative cable.

## REMOVAL AND INSTALLATION (Continued)

## INSTRUMENT PANEL PASSENGER SIDE BEZEL

**WARNING: ON VEHICLES EQUIPPED WITH AIRBAGS, REFER TO GROUP 8M - PASSIVE RESTRAINT SYSTEMS BEFORE ATTEMPTING ANY STEERING WHEEL, STEERING COLUMN, OR INSTRUMENT PANEL COMPONENT DIAGNOSIS OR SERVICE. FAILURE TO TAKE THE PROPER PRECAUTIONS COULD RESULT IN ACCIDENTAL AIRBAG DEPLOYMENT AND POSSIBLE PERSONAL INJURY.**

## REMOVAL

(1) Disconnect and isolate the battery negative cable.

(2) Remove the top pad from the instrument panel. Refer to **Instrument Panel Top Pad** in the Removal and Installation section of this group for the procedures.

(3) From the underside of the top pad, remove the four screws from the top of the passenger side airbag door that secure the passenger side bezel to the instrument panel (Fig. 31).

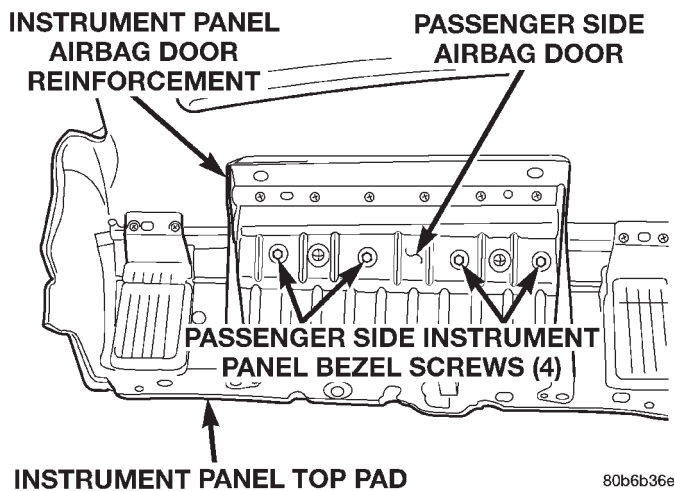

**Fig. 31 Instrument Panel Passenger Side Bezel Remove/Install**

(4) Remove the passenger side bezel from the instrument panel top pad.

## INSTALLATION

(1) Position the passenger side bezel to the instrument panel top pad.

(2) From the underside of the top pad, install and tighten the four screws through the top of the passenger side airbag door that secure the passenger side bezel to the instrument panel. Tighten the screws to 11.8 N·m (105 in. lbs.).

(3) Install the top pad onto the instrument panel. Refer to **Instrument Panel Top Pad** in the Removal and Installation section of this group for the procedures.

(4) Reconnect the battery negative cable.

## INSTRUMENT PANEL ASSEMBLY

**WARNING: ON VEHICLES EQUIPPED WITH AIRBAGS, REFER TO GROUP 8M - PASSIVE RESTRAINT SYSTEMS BEFORE ATTEMPTING ANY STEERING WHEEL, STEERING COLUMN, OR INSTRUMENT PANEL COMPONENT DIAGNOSIS OR SERVICE. FAILURE TO TAKE THE PROPER PRECAUTIONS COULD RESULT IN ACCIDENTAL AIRBAG DEPLOYMENT AND POSSIBLE PERSONAL INJURY.**

## REMOVAL

**NOTE: Before starting this procedure, be certain to turn the steering wheel until the front wheels are in the straight-ahead position.**

(1) Disconnect and isolate the battery negative cable.

(2) Remove the trim from the right and left A-pillars. Refer to **A-Pillar Trim** in the Removal and Installation section of Group 23 - Body for the procedures.

(3) Remove the top cover from the instrument panel. Refer to **Instrument Panel Top Cover** in the Removal and Installation section of this group for the procedures.

(4) Remove the four nuts that secure the instrument panel to the studs on the dash panel near the windshield fence line (Fig. 32).

(5) Remove the scuff plates from the right and left front door sills. Refer to **Front Door Scuff Plate** in the Removal and Installation section of Group 23 - Body for the procedures.

(6) Remove the trim panels from the right and left inner cowl sides. Refer to **Front Door Scuff Plate** in the Removal and Installation section of Group 23 - Body for the procedures.

(7) Remove the console from the floor panel transmission tunnel. Refer to **Floor Console** in the Removal and Installation section of Group 23 - Body for the procedures.

(8) Remove the fuse cover from the junction block. Refer to **Instrument Panel Fuse Cover** in the Removal and Installation section of this group for the procedures.



REMOVAL AND INSTALLATION (Continued)

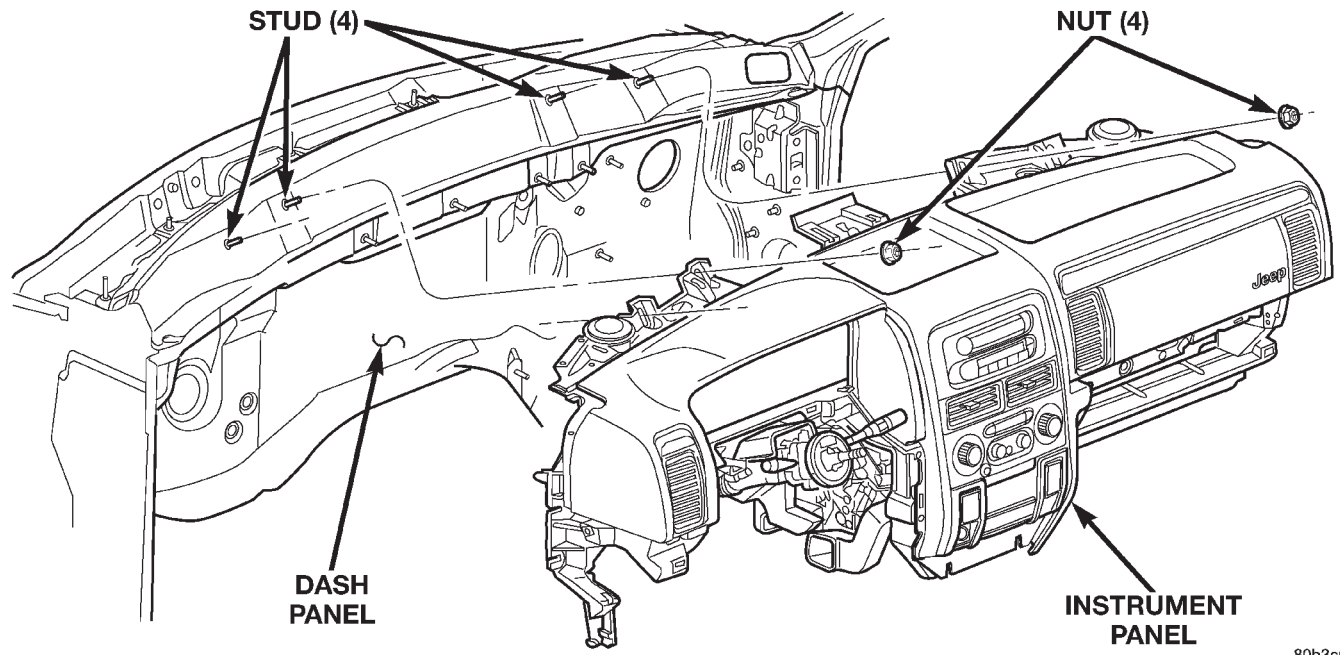

80b3c645

**Fig. 32 Instrument Panel to Dash Panel Mounting**

(9) Remove the cluster bezel from the instrument panel. Refer to **Cluster Bezel** in the Removal and Installation section of this group for the procedures.

(10) Remove the steering column opening cover from the instrument panel. Refer to **Steering Column Opening Cover** in the Removal and Installation section of this group for the procedures.

(11) Remove the steering column bracket from the instrument panel steering column support bracket. Refer to **Instrument Panel Steering Column Bracket** in the Removal and Installation section of this group for the procedures.

(12) Remove the screw that secures the lower tilting steering column shroud to the steering column multifunction switch mounting housing (Fig. 33).

(13) Unsnap the two halves of the tilting steering column shroud from each other and remove both halves from the steering column.

(14) Disconnect the instrument panel wire harness connectors from the following steering column components (Fig. 34):

- the two lower clockspring connector receptacles
- the left multifunction switch receptacle
- the right multifunction switch receptacle
- the two ignition switch receptacles
- the shifter interlock solenoid receptacle
- if the vehicle is so equipped, the Sentry Key Immobilizer Module (SKIM) receptacle.

(15) Turn the ignition switch to the On position, then release and remove the shifter interlock cable connector from the ignition lock housing receptacle.

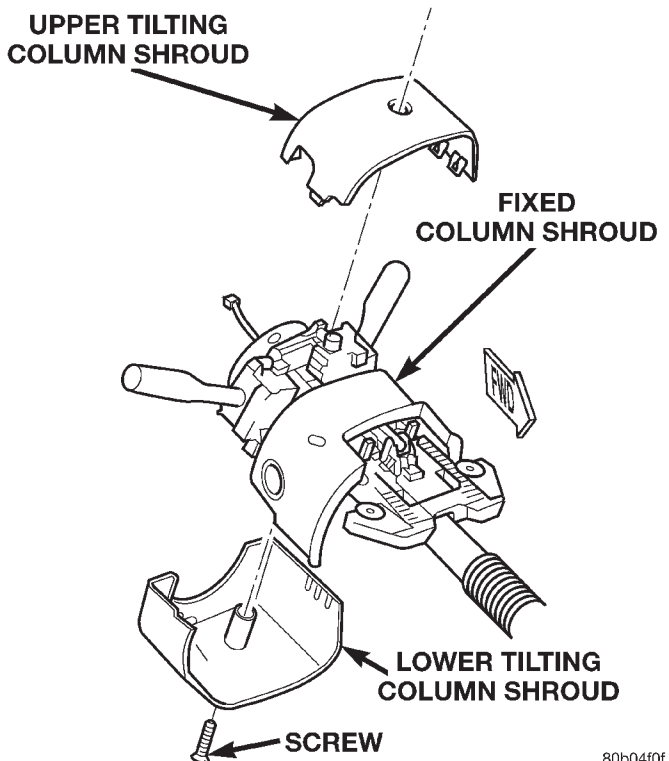

80b04f0f

**Fig. 33 Steering Column Shrouds Remove/Install**

(16) Turn the ignition switch back to the Lock position to prevent steering wheel rotation and the loss of clockspring centering following steering column removal.

## REMOVAL AND INSTALLATION (Continued)

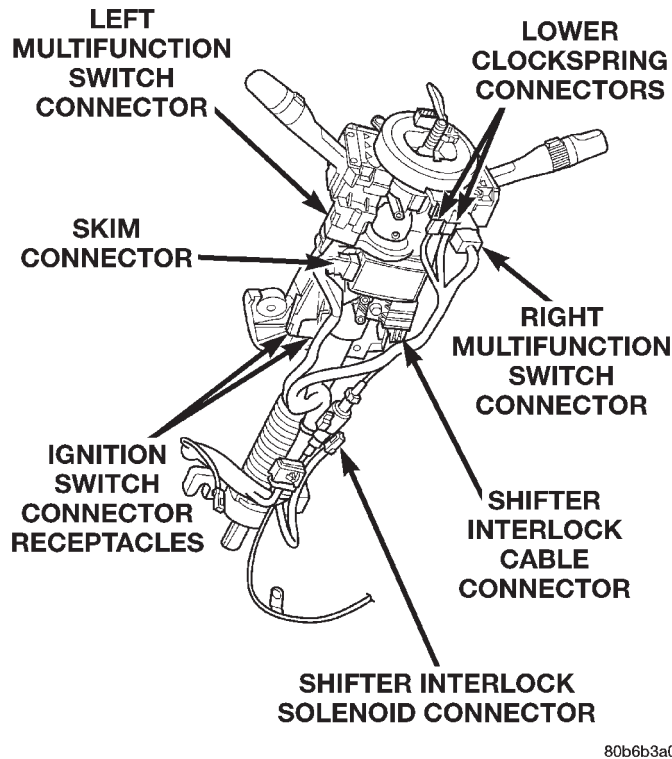

Fig. 34 Steering Column Connections

(17) Remove the bolt that secures the coupler to the lower steering column shaft (Fig. 35).

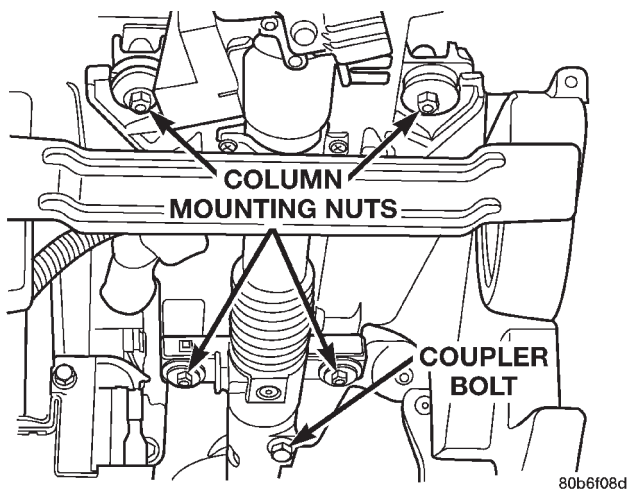

Fig. 35 Steering Column Mounting

(18) Remove the four nuts that secure the steering column to the studs on the instrument panel steering column support bracket.

(19) Remove the steering column from the instrument panel. Be certain that the steering wheel is locked and secured from rotation to prevent the loss of clockspring centering.

(20) Disconnect the left and right body wire harness bulkhead connectors, the Ignition Off Draw (IOD) wire harness connector and the fused B(+) wire harness connector from the connector receptacles of the junction block (Fig. 36).

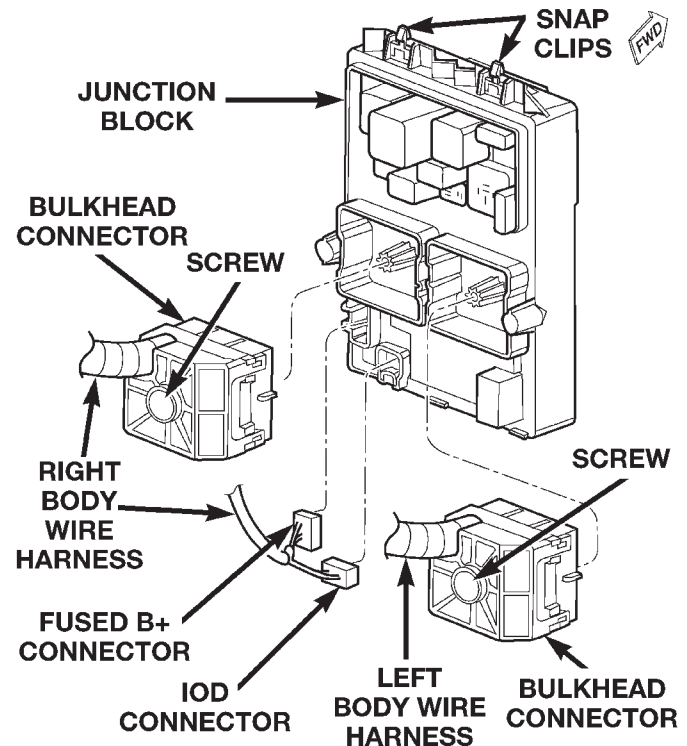

Fig. 36 Junction Block Connections

(21) Disconnect the instrument panel wire harness connectors from the following floor panel transmission tunnel components (Fig. 37):

- the airbag control module connector receptacle
- the park brake switch terminal
- the transmission shifter connector receptacle.

(22) Remove the two nuts that secure the instrument panel wire harness ground eyelets to the studs on the floor panel transmission tunnel in front of and behind the airbag control module.

(23) Disengage the retainers that secure the instrument panel wire harness to the floor panel transmission tunnel.

(24) Remove the instrument panel to center floor tunnel bracket from the instrument panel and the floor panel transmission tunnel. Refer to **Instrument Panel to Center Floor Tunnel Bracket** in the Removal and Installation section of this group for the procedures.

(25) Remove the one screw that secures the driver side floor duct to the heater and air conditioner housing near the driver side of the floor panel transmission tunnel and remove the duct from the housing.

REMOVAL AND INSTALLATION (Continued)

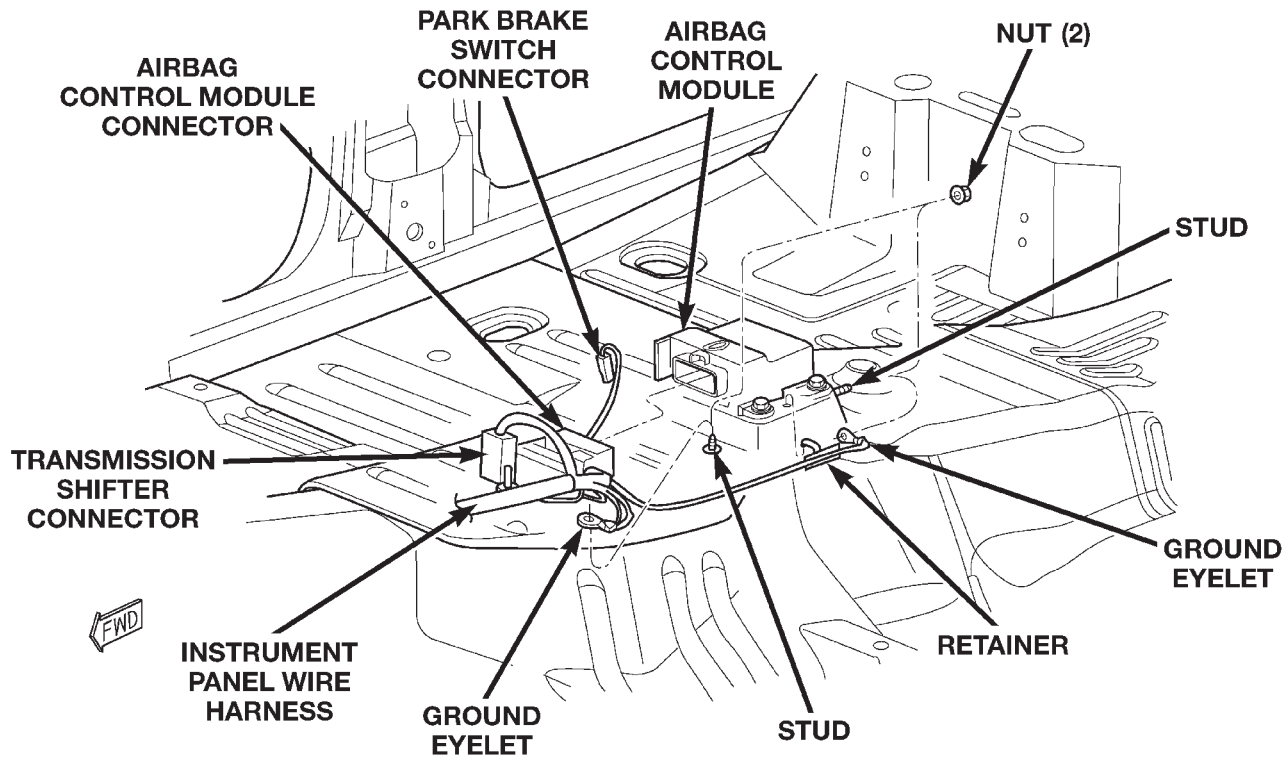

80b3c644

**Fig. 37 Floor Panel Transmission Tunnel Connections**

(26) If the vehicle is equipped with the manual heating and air conditioning system, disconnect the vacuum harness connector located near the driver side of the floor panel transmission tunnel behind the driver side floor duct.

(27) Remove the one screw that secures the instrument panel steering column support bracket to the driver side end of the heater and air conditioner housing (Fig. 38).

(28) Remove the one screw that secures the instrument panel steering column support bracket to the intermediate bracket on the driver side dash panel (Fig. 39).

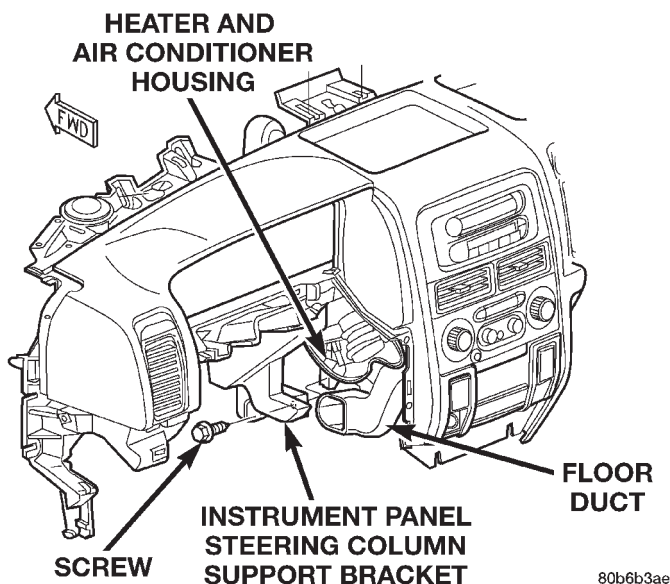

80b6b3ae

**Fig. 38 Driver Side Instrument Panel to Heater-A/C Housing Mounting**

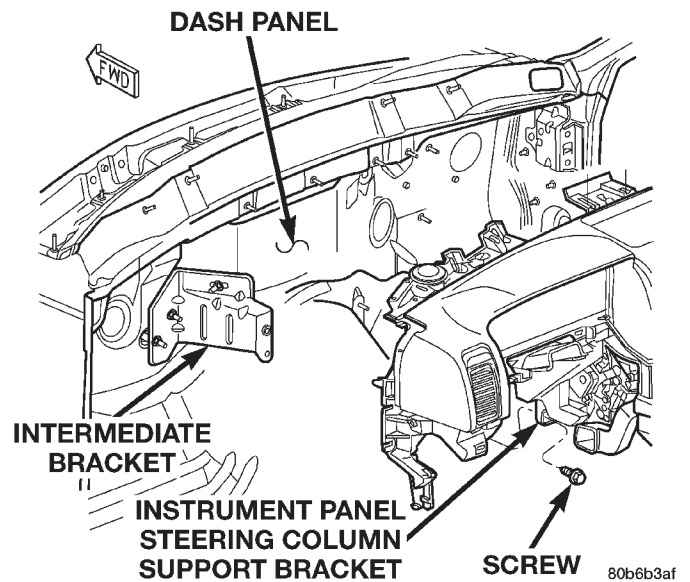

80b6b3af

**Fig. 39 Instrument Panel to Intermediate Bracket Mounting**

## REMOVAL AND INSTALLATION (Continued)

(29) Remove the nut that secures the instrument panel steering column support bracket to the stud on the driver side cowl plenum panel (Fig. 40).

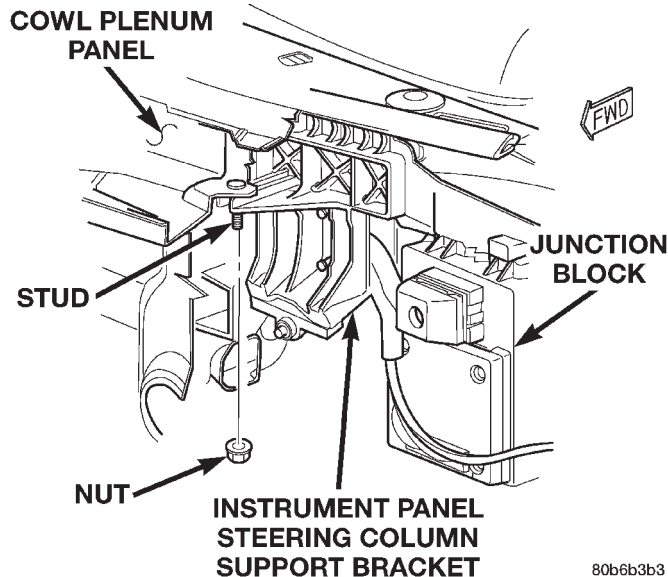

80b6b3b3

**Fig. 40 Instrument Panel to Cowl Plenum Mounting**

(30) Remove the two screws that secure the instrument panel to the driver side cowl side inner panel (Fig. 41).

(31) Remove the end cap from the instrument panel. Refer to **Instrument Panel End Cap** in the Removal and Installation section of this group for the procedures.

(32) Remove the lower right center bezel from the instrument panel. Refer to **Instrument Panel Lower Right Center Bezel** in the Removal and Installation section of this group for the procedures.

(33) Disconnect the instrument panel wire harness bulkhead connector from the lower cavity of the inline connector on the passenger side cowl side inner panel (Fig. 42).

(34) Disconnect the two halves of the radio antenna coaxial cable connector near the right cowl side inner panel under the end of the instrument panel.

(35) Disconnect the two instrument panel wire harness connectors from the two heater and air conditioner housing connectors located near the blower motor on the passenger side end of the housing (Fig. 43).

(36) Remove the two screws that secure the passenger side instrument panel structural duct to the heater and air conditioner housing (Fig. 44).

(37) Remove the two screws that secure the instrument panel to the passenger side cowl side inner panel (Fig. 45).

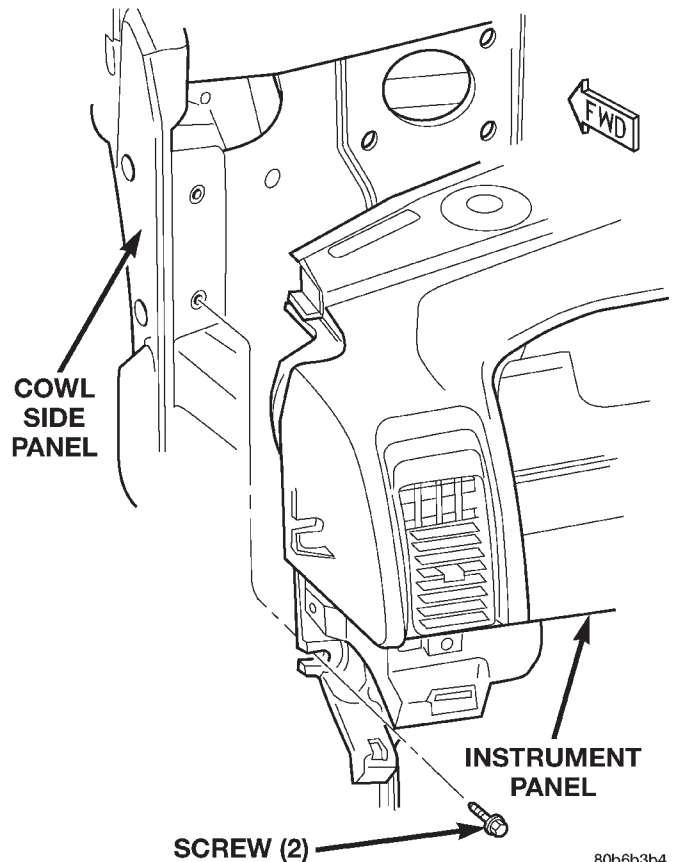

80b6b3b4

**Fig. 41 Instrument Panel to Driver Side Cowl Side Inner Panel Mounting**

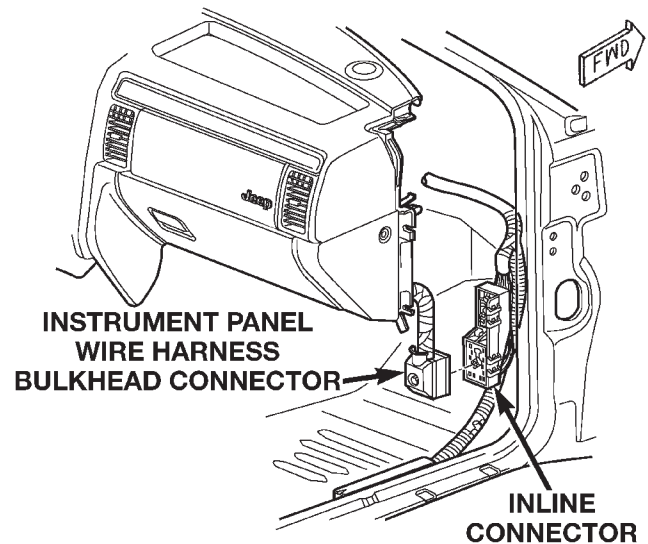

80b6b3b6

**Fig. 42 Instrument Panel Passenger Side Bulkhead Connection**

REMOVAL AND INSTALLATION (Continued)

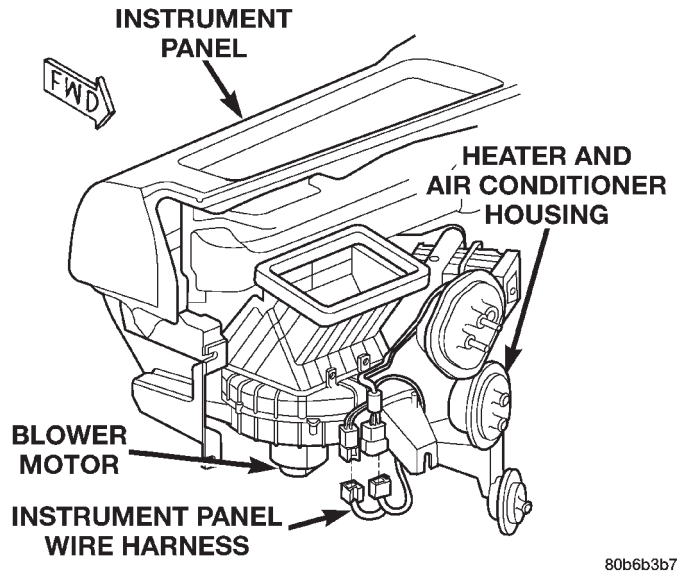

**Fig. 43 Heater and Air Conditioner Housing Connections**

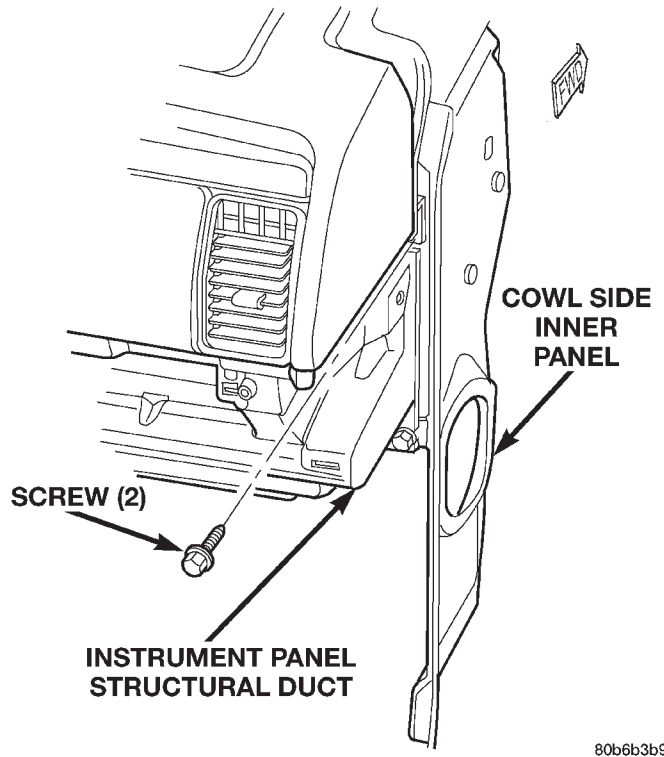

**Fig. 45 Instrument Panel to Passenger Side Cowl Side Inner Panel Mounting**

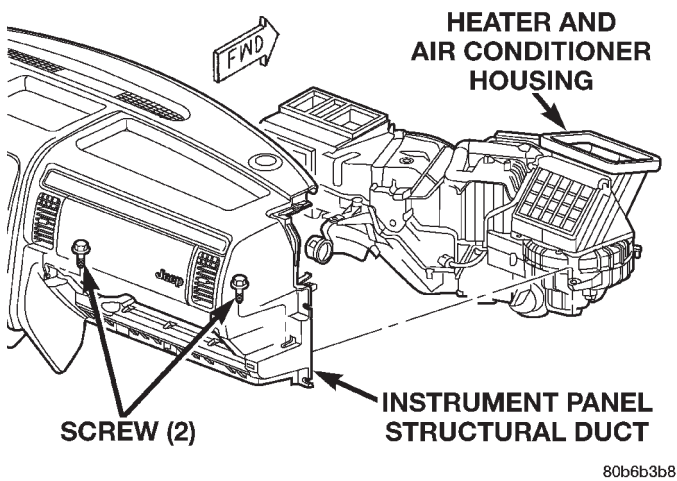

**Fig. 44 Passenger Side Instrument Panel to Heater/A/C Housing Mounting**

(38) With the aid of an assistant, lift the instrument panel assembly upward off of the studs on the dash panel near the windshield fence line and to disengage the molded plastic hook formations on the instrument panel structural duct from the guide holes at each cowl side inner panel.

(39) Pull the instrument panel rearward from the dash panel and the cowl side inner panels and remove it through the driver side front door of the vehicle.

**INSTALLATION**

(1) Prior to installing the instrument panel into the vehicle, loosen the three nuts that secure the instrument panel intermediate bracket and the accelerator pedal assembly to the studs on the dash panel.

(2) With the aid of an assistant, load the instrument panel assembly through the driver side front door of the vehicle and hang it on the studs on the dash panel near the windshield fence line.

(3) Be certain that the molded plastic hook formations on the instrument panel structural duct are inserted into and seated in the guide holes at each cowl side inner panel.

(4) Loosely install the two screws that secure each end of the instrument panel to the cowl side inner panels.

(5) Install and tighten the two screws that secure the passenger side instrument panel structural duct to the heater and air conditioner housing. Tighten the screws to 11.8 N·m (105 in. lbs.).

(6) Install and tighten the one screw that secures the instrument panel steering column support bracket to the driver side end of the heater and air conditioner housing. Tighten the screw to 11.8 N·m (105 in. lbs.).

(7) Tighten the two screws that secure each end of the instrument panel to the cowl side inner panels. Tighten the screws to 11.8 N·m (105 in. lbs.).

(8) Install and tighten the one screw that secures the instrument panel steering column support bracket to the intermediate bracket on the driver side dash panel. Tighten the screw to 11.3 N·m (100 in. lbs.).

## REMOVAL AND INSTALLATION (Continued)

(9) Tighten the three nuts that secure the instrument panel intermediate bracket and the accelerator pedal assembly to the studs on the dash panel. Tighten the nuts to 11.3 N·m (100 in. lbs.).

(10) Install and tighten the four nuts that secure the instrument panel to the studs on the dash panel near the windshield fence line. Tighten the nuts to 11.8 N·m (105 in. lbs.).

(11) Install and tighten the nut that secures the instrument panel steering column support bracket to the stud on the driver side cowl plenum panel. Tighten the nut to 28.2 N·m (250 in. lbs.).

(12) Install the instrument panel to center floor tunnel bracket onto the instrument panel and the floor panel transmission tunnel. Refer to **Instrument Panel to Center Floor Tunnel Bracket** in the Removal and Installation section of this group for the procedures.

(13) Reconnect the two instrument panel wire harness connectors to the two heater and air conditioner housing connectors located near the blower motor on the passenger side end of the housing.

(14) Reconnect the two halves of the radio antenna coaxial cable connector near the right cowl side inner panel under the end of the instrument panel.

(15) Reconnect the instrument panel wire harness bulkhead connector to the lower cavity of the inline connector on the passenger side cowl side inner panel and tighten the connector screw. Tighten the screw to 4 N·m (36 in. lbs.).

(16) Install the lower right center bezel onto the instrument panel. Refer to **Instrument Panel Lower Right Center Bezel** in the Removal and Installation section of this group for the procedures.

(17) Install the end cap onto the instrument panel. Refer to **Instrument Panel End Cap** in the Removal and Installation section of this group for the procedures.

(18) If the vehicle is equipped with the manual heating and air conditioning system, reconnect the vacuum harness connector located near the driver side of the floor panel transmission tunnel behind the driver side floor duct.

(19) Position the driver side floor duct to the heater and air conditioner housing near the driver side of the floor panel transmission tunnel.

(20) Install and tighten the one screw that secures the driver side floor duct to the heater and air conditioner housing near the driver side of the floor panel transmission tunnel. Tighten the screw to 2.2 N·m (20 in. lbs.).

(21) Route the instrument panel wire harness to the floor panel transmission tunnel and engage the retainers that secure the harness to the mounting brackets on the tunnel.

(22) Install the instrument panel wire harness ground eyelets to the studs on the floor panel transmission tunnel in front of and behind the airbag control module and secure the eyelets with nuts. Tighten the nuts to 7.3 N·m (65 in. lbs.).

(23) Reconnect the instrument panel wire harness connectors to the following floor panel transmission tunnel components:

- the airbag control module connector receptacle
- the park brake switch terminal
- the transmission shifter connector receptacle.

(24) Reconnect the left and right body wire harness bulkhead connectors, the Ignition Off Draw (IOD) wire harness connector and the fused B+ wire harness connector to the connector receptacles of the junction block. Tighten the bulkhead connector screws. Tighten the screws to 4 N·m (36 in. lbs.).

(25) Engage the lower steering column shaft with the steering shaft coupler and position the steering column to the mounting studs on the instrument panel steering column support bracket.

(26) Install and tighten the four nuts that secure the steering column to the studs on the instrument panel steering column support bracket. Tighten the nuts to 11.8 N·m (105 in. lbs.).

(27) Install and tighten the bolt that secures the coupler to the lower steering column shaft. Tighten the bolt to 49 N·m (36 ft. lbs.).

(28) Turn the ignition switch to the On position, then install the shifter interlock cable connector into the ignition lock housing receptacle.

(29) Reconnect the instrument panel wire harness connectors to the following steering column components (Fig. 34):

- the two lower clockspring connector receptacles
- the left multifunction switch receptacle
- the right multifunction switch receptacle
- the two ignition switch receptacles
- the shifter interlock solenoid receptacle
- if the vehicle is so equipped, the Sentry Key Immobilizer Module (SKIM) receptacle.

(30) Position the lower tilting steering column shroud to the steering column multifunction switch mounting housing, then install and tighten the screw that secures the shroud to the housing. Tighten the screw to 1.9 N·m (17 in. lbs.).

(31) Position the upper tilting steering column shroud over the steering column. Align the upper and lower shrouds with each other and snap the two halves together.

(32) Install the steering column bracket onto the instrument panel steering column support bracket. Refer to **Instrument Panel Steering Column Bracket** in the Removal and Installation section of this group for the procedures.

## REMOVAL AND INSTALLATION (Continued)

(33) Install the steering column opening cover onto the instrument panel. Refer to **Steering Column Opening Cover** in the Removal and Installation section of this group for the procedures.

(34) Install the cluster bezel onto the instrument panel. Refer to **Cluster Bezel** in the Removal and Installation section of this group for the procedures.

(35) Install the fuse cover onto the junction block. Refer to **Instrument Panel Fuse Cover** in the Removal and Installation section of this group for the procedures.

(36) Install the console onto the floor panel transmission tunnel. Refer to **Floor Console** in the Removal and Installation section of Group 23 - Body for the procedures.

(37) Install the trim panels onto the right and left inner cowl sides. Refer to **Front Door Scuff Plate** in the Removal and Installation section of Group 23 - Body for the procedures.

(38) Install the scuff plates onto the right and left front door sills. Refer to **Front Door Scuff Plate** in the Removal and Installation section of Group 23 - Body for the procedures.

(39) Install the top cover onto the instrument panel. Refer to **Instrument Panel Top Cover** in the Removal and Installation section of this group for the procedures.

(40) Install the trim onto the right and left A-pillars. Refer to **A-Pillar Trim** in the Removal and Installation section of Group 23 - Body for the procedures.

(41) Reconnect the battery negative cable.

## INSTRUMENT PANEL C-CHANNEL COVER BRACKET

**WARNING: ON VEHICLES EQUIPPED WITH AIR-BAGS, REFER TO GROUP 8M - PASSIVE RESTRAINT SYSTEMS BEFORE ATTEMPTING ANY STEERING WHEEL, STEERING COLUMN, OR INSTRUMENT PANEL COMPONENT DIAGNOSIS OR SERVICE. FAILURE TO TAKE THE PROPER PRECAUTIONS COULD RESULT IN ACCIDENTAL AIR-BAG DEPLOYMENT AND POSSIBLE PERSONAL INJURY.**

### REMOVAL

(1) Disconnect and isolate the battery negative cable.

(2) Remove the instrument panel from the vehicle. Refer to **Instrument Panel Assembly** in the Removal and Installation section of this group for the procedures.

(3) Place the instrument panel top down on a suitable work surface. Be certain to take the proper pre-

cautions to protect the top of the instrument panel from any possible cosmetic damage.

(4) Disengage the radio antenna coaxial cable retainer from the mounting hole in the instrument panel wire harness mounting tab on the passenger side outboard end of the instrument panel C-channel cover bracket.

(5) Remove the screw that secures the instrument panel wire harness mounting tab on the passenger side outboard end of the instrument panel C-channel cover bracket (Fig. 46).

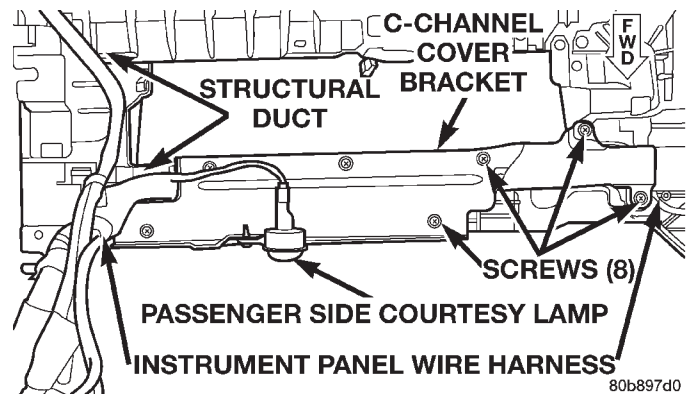

**Fig. 46 Instrument Panel C-Channel Cover Bracket Remove/Install**

(6) Remove the screw that secures the passenger side courtesy lamp to the lower tab of instrument panel C-channel cover bracket.

(7) Remove the eight screws that secure the C-channel cover bracket to the instrument panel structural duct.

(8) Remove the C-channel cover bracket from the instrument panel structural duct.

### INSTALLATION

(1) Position the C-channel cover bracket to the instrument panel structural duct.

(2) Install and tighten the eight screws that secure the C-channel cover bracket to the instrument panel structural duct. Tighten the screws to 2.2 N·m (20 in. lbs.).

(3) Position the passenger side courtesy lamp to the lower tab of instrument panel C-channel cover bracket.

(4) Install and tighten the screw that secures the passenger side courtesy lamp to the lower tab of instrument panel C-channel cover bracket. Tighten the screw to 2.2 N·m (20 in. lbs.).

(5) Position the instrument panel wire harness mounting tab to the passenger side outboard end of the instrument panel C-channel cover bracket.

(6) Install and tighten the screw that secures the instrument panel wire harness mounting tab to the passenger side outboard end of the instrument panel

## REMOVAL AND INSTALLATION (Continued)

C-channel cover bracket. Tighten the screw to 2.2 N·m (20 in. lbs.).

(7) Engage the radio antenna coaxial cable retainer in the mounting hole in the instrument panel wire harness mounting tab on the passenger side outboard end of the instrument panel C-channel cover bracket.

(8) Install the instrument panel into the vehicle. Refer to **Instrument Panel Assembly** in the Removal and Installation section of this group for the procedures.

(9) Reconnect the battery negative cable.

## INSTRUMENT PANEL INTERMEDIATE BRACKET

**WARNING: ON VEHICLES EQUIPPED WITH AIR-BAGS, REFER TO GROUP 8M - PASSIVE RESTRAINT SYSTEMS BEFORE ATTEMPTING ANY STEERING WHEEL, STEERING COLUMN, OR INSTRUMENT PANEL COMPONENT DIAGNOSIS OR SERVICE. FAILURE TO TAKE THE PROPER PRECAUTIONS COULD RESULT IN ACCIDENTAL AIR-BAG DEPLOYMENT AND POSSIBLE PERSONAL INJURY.**

## REMOVAL

(1) Disconnect and isolate the battery negative cable.

(2) Remove the accelerator pedal assembly from the shoulder studs on the dash panel. Refer to **Accelerator Pedal** in the Removal and Installation section of Group 14 - Fuel System for the procedures.

(3) Remove the instrument panel from the vehicle. Refer to **Instrument Panel Assembly** in the Removal and Installation section of this group for the procedures.

(4) Remove the one nut that secures the instrument panel intermediate bracket to the stud on the dash panel (Fig. 47).

(5) Remove the instrument panel intermediate bracket from the two shoulder studs and the one stud on the dash panel.

## INSTALLATION

(1) Position the instrument panel intermediate bracket to the two shoulder studs and the one stud on the dash panel.

(2) Loosely install the one nut that secures the instrument panel intermediate bracket to the one stud on the dash panel.

(3) Install the instrument panel into the vehicle. Refer to **Instrument Panel Assembly** in the Removal and Installation section of this group for the procedures.

(4) Install the accelerator pedal assembly onto the shoulder studs on the dash panel. Refer to **Accelerator**

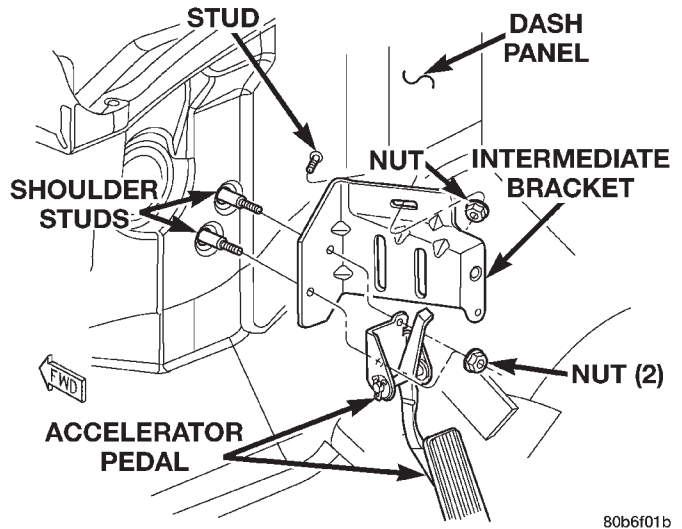

80b6f01b

*Fig. 47 Instrument Panel Intermediate Bracket Remove/Install*

**ator Pedal** in the Removal and Installation section of Group 14 - Fuel System for the procedures.

(5) Reconnect the battery negative cable.

## INSTRUMENT PANEL PLENUM BRACKET

**WARNING: ON VEHICLES EQUIPPED WITH AIR-BAGS, REFER TO GROUP 8M - PASSIVE RESTRAINT SYSTEMS BEFORE ATTEMPTING ANY STEERING WHEEL, STEERING COLUMN, OR INSTRUMENT PANEL COMPONENT DIAGNOSIS OR SERVICE. FAILURE TO TAKE THE PROPER PRECAUTIONS COULD RESULT IN ACCIDENTAL AIR-BAG DEPLOYMENT AND POSSIBLE PERSONAL INJURY.**

## REMOVAL

(1) Disconnect and isolate the battery negative cable.

(2) Remove the instrument panel from the vehicle. Refer to **Instrument Panel Assembly** in the Removal and Installation section of this group for the procedures.

(3) Place the instrument panel top down on a suitable work surface. Be certain to take the proper precautions to protect the top of the instrument panel from any possible cosmetic damage.

(4) Remove the one screw that secures the plenum bracket to the instrument panel steering column support bracket (Fig. 48).

(5) Remove the plenum bracket from the instrument panel steering column support bracket.

## INSTALLATION

(1) Position the plenum bracket to the instrument panel steering column support bracket.



## REMOVAL AND INSTALLATION (Continued)

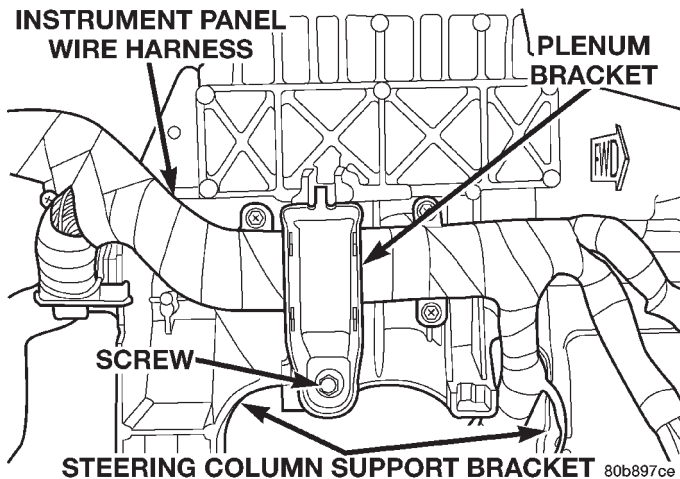

**Fig. 48 Instrument Panel Plenum Bracket Remove/Install**

(2) Install and tighten the one screw that secures the plenum bracket to the instrument panel steering column support bracket. Tighten the screw to 11.8 N·m (105 in. lbs.).

(3) Install the instrument panel into the vehicle. Refer to **Instrument Panel Assembly** in the Removal and Installation section of this group for the procedures.

(4) Reconnect the battery negative cable.

## INSTRUMENT PANEL STEERING COLUMN SUPPORT BRACKET

**WARNING: ON VEHICLES EQUIPPED WITH AIRBAGS, REFER TO GROUP 8M - PASSIVE RESTRAINT SYSTEMS BEFORE ATTEMPTING ANY STEERING WHEEL, STEERING COLUMN, OR INSTRUMENT PANEL COMPONENT DIAGNOSIS OR SERVICE. FAILURE TO TAKE THE PROPER PRECAUTIONS COULD RESULT IN ACCIDENTAL AIRBAG DEPLOYMENT AND POSSIBLE PERSONAL INJURY.**

### REMOVAL

(1) Disconnect and isolate the battery negative cable.

(2) Remove the instrument cluster from the instrument panel. Refer to **Instrument Cluster** in the Removal and Installation section of this group for the procedures.

(3) Remove the instrument panel plenum bracket from the steering column support bracket. Refer to **Instrument Panel Plenum Bracket** in the Removal and Installation section of this group for the procedures.

(4) Remove the three screws that secure the instrument panel wire harness mounting tabs to the back of the steering column support bracket.

(5) Remove the two screws that secure the 16-way data link connector to the instrument panel steering column support bracket and remove the connector from the bracket (Fig. 49).

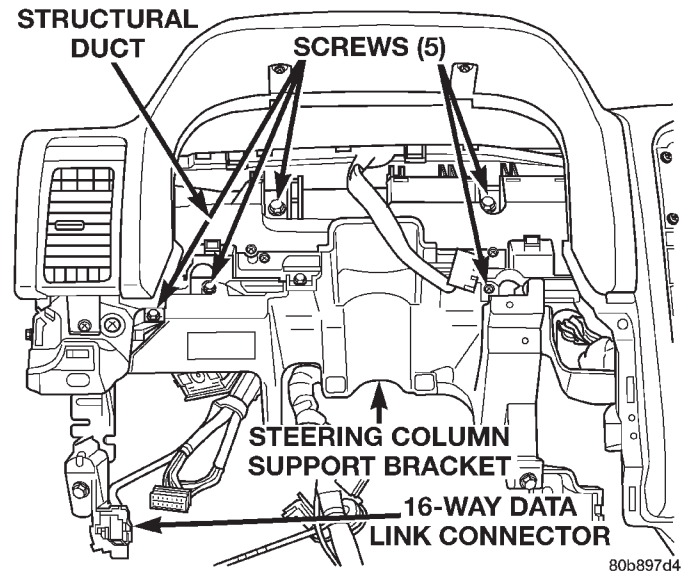

**Fig. 49 Instrument Panel Steering Column Support Bracket Remove/Install**

(6) Remove the junction block and the body control module from the instrument panel steering column support bracket as a unit, but do not disconnect any of the instrument panel wire harness connectors from the unit. Refer to **Junction Block** in the Removal and Installation section of Group 80 - Power Distribution Systems for the procedures.

(7) From the face of the instrument panel, remove the five screws that secure the steering column support bracket to the instrument panel structural duct.

(8) Remove the steering column support bracket from the instrument panel structural duct.

### INSTALLATION

(1) Position the steering column support bracket to the instrument panel structural duct.

(2) From the face of the instrument panel, install and tighten the five screws that secure the steering column support bracket to the instrument panel structural duct. Tighten the screws to 11.8 N·m (105 in. lbs.).

(3) Position the instrument panel wire harness mounting tabs to the back of the steering column support bracket.

(4) Install and tighten the three screws that secure the instrument panel wire harness mounting tabs to the back of the steering column support bracket. Tighten the screws to 2.2 N·m (20 in. lbs.).

## REMOVAL AND INSTALLATION (Continued)

(5) Install the instrument panel plenum bracket onto the steering column support bracket. Refer to **Instrument Panel Plenum Bracket** in the Removal and Installation section of this group for the procedures.

(6) Install the junction block and the body control module onto the instrument panel steering column support bracket as a unit. Refer to **Junction Block** in the Removal and Installation section of Group 80 - Power Distribution Systems for the procedures.

(7) Position the 16-way data link connector to the instrument panel steering column support bracket.

(8) Install and tighten the two screws that secure the 16-way data link connector to the instrument panel steering column support bracket. Tighten the screws to 2.2 N·m (20 in. lbs.).

(9) Install the instrument cluster onto the instrument panel. Refer to **Instrument Cluster** in the Removal and Installation section of this group for the procedures.

(10) Reconnect the battery negative cable.

## INSTRUMENT PANEL STRUCTURAL DUCT

**WARNING: ON VEHICLES EQUIPPED WITH AIR-BAGS, REFER TO GROUP 8M - PASSIVE RESTRAINT SYSTEMS BEFORE ATTEMPTING ANY STEERING WHEEL, STEERING COLUMN, OR INSTRUMENT PANEL COMPONENT DIAGNOSIS OR SERVICE. FAILURE TO TAKE THE PROPER PRE-**

**CAUTIONS COULD RESULT IN ACCIDENTAL AIR-BAG DEPLOYMENT AND POSSIBLE PERSONAL INJURY.**

## REMOVAL

(1) Disconnect and isolate the battery negative cable.

(2) Remove the instrument panel from the vehicle. Refer to **Instrument Panel Assembly** in the Removal and Installation section of this group for the procedures.

(3) Place the instrument panel on a suitable work surface. Be certain to take the proper precautions to protect the instrument panel from any possible cosmetic damage.

(4) Remove all of the individual components that are secured to the instrument panel structural duct as described in this service manual.

## INSTALLATION

(1) Install all of the individual components that were removed from the instrument panel structural duct as described in this service manual.

(2) Install the instrument panel into the vehicle. Refer to **Instrument Panel Assembly** in the Removal and Installation section of this group for the procedures.

(3) Reconnect the battery negative cable.