

# TIRES AND WHEELS

## CONTENTS

	page		page
TIRES .....	1	WHEELS .....	7

## TIRES

### INDEX

	page		page
<b>DESCRIPTION AND OPERATION</b>		TIRE WEAR PATTERNS .....	3
RADIAL-PLY TIRES .....	2	TREAD WEAR INDICATORS .....	3
REPLACEMENT TIRES .....	3	<b>SERVICE PROCEDURES</b>	
SPARE TIRE-TEMPORARY .....	2	MATCH MOUNTING .....	4
TIRE INFLATION PRESSURES .....	2	REPAIRING LEAKS .....	6
TIRE PRESSURE FOR HIGH SPEED		ROTATION .....	4
OPERATION .....	3	<b>CLEANING AND INSPECTION</b>	
TIRES .....	1	CLEANING TIRES .....	6
<b>DIAGNOSIS AND TESTING</b>		<b>SPECIFICATIONS</b>	
PRESSURE GAUGES .....	3	TIRES .....	6
TIRE NOISE OR VIBRATION .....	4		

## DESCRIPTION AND OPERATION

### TIRES

Tires are designed and engineered for each specific vehicle. They provide the best overall performance for normal operation. The ride and handling characteristics match the vehicle's requirements. With proper care they will give excellent reliability, traction, skid resistance, and tread life.

Driving habits have more effect on tire life than any other factor. Careful drivers will obtain in most cases, much greater mileage than severe use or careless drivers. A few of the driving habits which will shorten the life of any tire are:

- Rapid acceleration
- Severe brake applications
- High speed driving
- Excessive speeds on turns
- Striking curbs and other obstacles

Radial-ply tires are more prone to irregular tread wear. It is important to follow the tire rotation interval shown in the section on Tire Rotation. This will help to achieve a greater tread life.

### TIRE IDENTIFICATION

Tire type, size, aspect ratio and speed rating are encoded in the letters and numbers imprinted on the side wall of the tire. Refer to the chart to decipher the tire identification code (Fig. 1).

Performance tires have a speed rating letter after the aspect ratio number. The speed rating is not always printed on the tire sidewall. These ratings are:

- **Q** up to 100 mph
- **S** up to 112 mph
- **T** up to 118 mph
- **U** up to 124 mph
- **H** up to 130 mph
- **V** up to 149 mph
- **Z** more than 149 mph (consult the tire manufacturer for the specific speed rating)

An All Season type tire will have either **M + S**, **M & S** or **M-S** (indicating mud and snow traction) imprinted on the side wall.

### TIRE CHAINS

Tire snow chains may be used on **certain** models. Refer to the Owner's Manual for more information.

DESCRIPTION AND OPERATION (Continued)

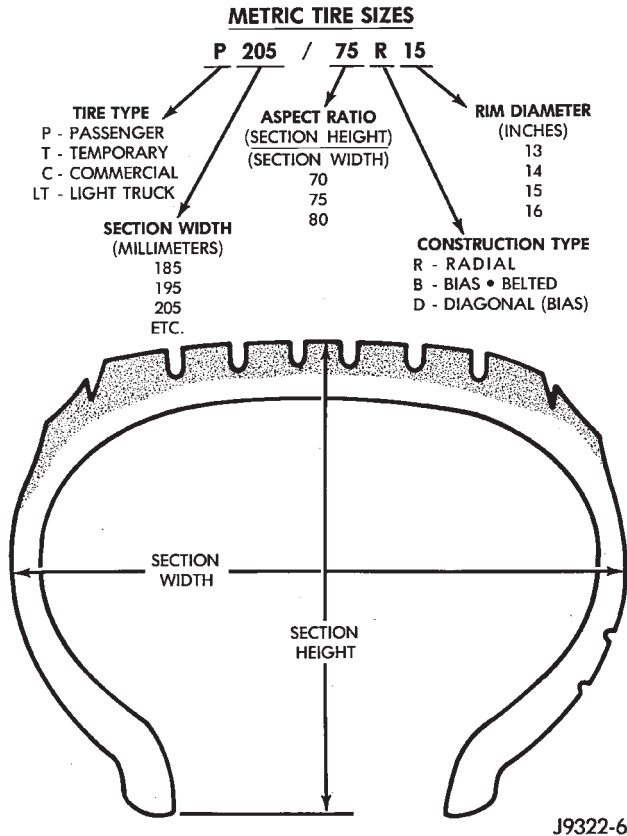

**Fig. 1 Tire Identification**

**RADIAL-PLY TIRES**

Radial-ply tires improve handling, tread life and ride quality, and decrease rolling resistance.

Radial-ply tires must always be used in sets of four. Under no circumstances should they be used on the front only. They may be mixed with temporary spare tires when necessary. A maximum speed of 50 MPH is recommended while a temporary spare is in use.

Radial-ply tires have the same load-carrying capacity as other types of tires of the same size. They also use the same recommended inflation pressures.

The use of oversized tires, either in the front or rear of the vehicle, can cause vehicle drive train failure. This could also cause inaccurate wheel speed signals when the vehicle is equipped with Anti-Lock Brakes.

The use of tires from different manufactures on the same vehicle is NOT recommended. The proper tire pressure should be maintained on all four tires.

**SPARE TIRE-TEMPORARY**

The temporary spare tire is designed for emergency use only. The original tire should be repaired or replaced at the first opportunity and reinstall. Do not exceed speeds of 50 MPH. Refer to Owner's Manual for complete details.

**TIRE INFLATION PRESSURES**

Under inflation will cause rapid shoulder wear, tire flexing, and possible tire failure (Fig. 2).

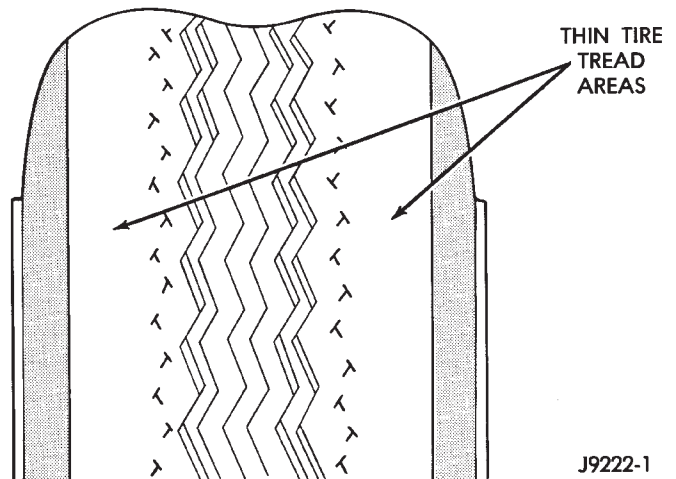

**Fig. 2 Under Inflation Wear**

Over inflation will cause rapid center wear and loss of the tire's ability to cushion shocks (Fig. 3).

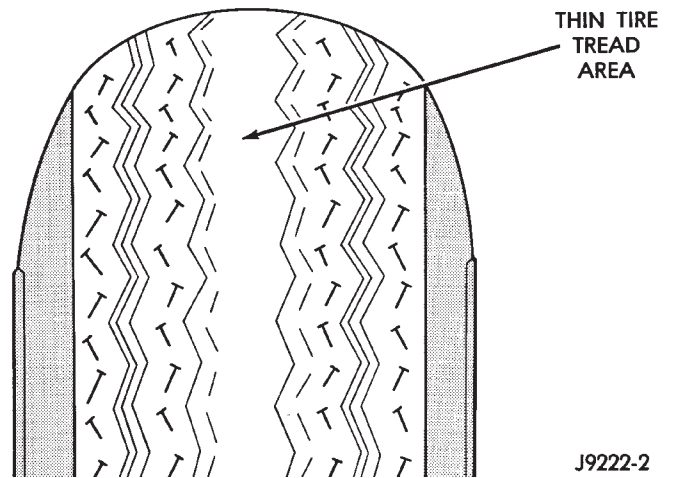

**Fig. 3 Over Inflation Wear**

Improper inflation can cause:

- Uneven wear patterns
- Reduced tread life
- Reduced fuel economy
- Unsatisfactory ride
- Vehicle drift

For proper tire pressure specification refer to the Tire Inflation Pressure Chart provided with the vehicles Owners Manual. A Certification Label on the drivers side door pillar provides the minimum tire and rim size for the vehicle. The label also list the cold inflation pressure for these tires at full load operation.

Tire pressures have been chosen to provide safe operation, vehicle stability, and a smooth ride. Tire pressure should be checked cold once a month. Tire

DESCRIPTION AND OPERATION (Continued)

pressure decreases as the ambient temperature drops. Check tire pressure frequently when ambient temperature varies widely.

Tire inflation pressures are cold inflation pressure. The vehicle must sit for at least 3 hours to obtain the correct cold inflation pressure reading. Or be driven less than one mile after sitting for 3 hours. Tire inflation pressures may increase from 2 to 6 pounds per square inch (psi) during operation. Do not reduce this normal pressure build-up.

**WARNING: OVER OR UNDER INFLATED TIRES CAN AFFECT VEHICLE HANDLING AND TREAD WEAR. THIS MAY CAUSE THE TIRE TO FAIL SUDDENLY, RESULTING IN LOSS OF VEHICLE CONTROL.**

**TIRE PRESSURE FOR HIGH SPEED OPERATION**

Chrysler Corporation advocates driving at safe speeds within posted speed limits. Where speed limits allow the vehicle to be driven at high speeds, correct tire inflation pressure is very important. For speeds up to and including 120 km/h (75 mph), tires must be inflated to the pressures shown on the tire placard. For continuous speeds in excess of 120 km/h (75 mph), tires must be inflated to the maximum pressure specified on the tire sidewall.

Vehicles loaded to the maximum capacity should not be driven at continuous speeds above 75 mph (120 km/h).

For emergency vehicles that are driven at speeds over 90 mph (144 km/h), special high speed tires must be used. Consult tire manufacturer for correct inflation pressure recommendations.

**REPLACEMENT TIRES**

The original equipment tires provide a proper balance of many characteristics such as:

- Ride
- Noise
- Handling
- Durability
- Tread life
- Traction
- Rolling resistance
- Speed capability

It is recommend that tires equivalent to the original equipment tires be used when replacement is needed.

Failure to use equivalent replacement tires may adversely affect the safety and handling of the vehicle.

The use of oversize tires not listed in the specification charts may cause interference with vehicle components. Under extremes of suspension and steering

travel, interference with vehicle components may cause tire damage.

**WARNING: FAILURE TO EQUIP THE VEHICLE WITH TIRES HAVING ADEQUATE SPEED CAPABILITY CAN RESULT IN SUDDEN TIRE FAILURE.**

DIAGNOSIS AND TESTING

**PRESSURE GAUGES**

A quality air pressure gauge is recommended to check tire pressure. After checking the air pressure, replace valve cap finger tight.

**TREAD WEAR INDICATORS**

Tread wear indicators are molded into the bottom of the tread grooves. When tread depth is 1.6 mm (1/16 in.), the tread wear indicators will appear as a 13 mm (1/2 in.) band (Fig. 4).

Tire replacement is necessary when indicators appear in two or more grooves or if localized balding occurs.

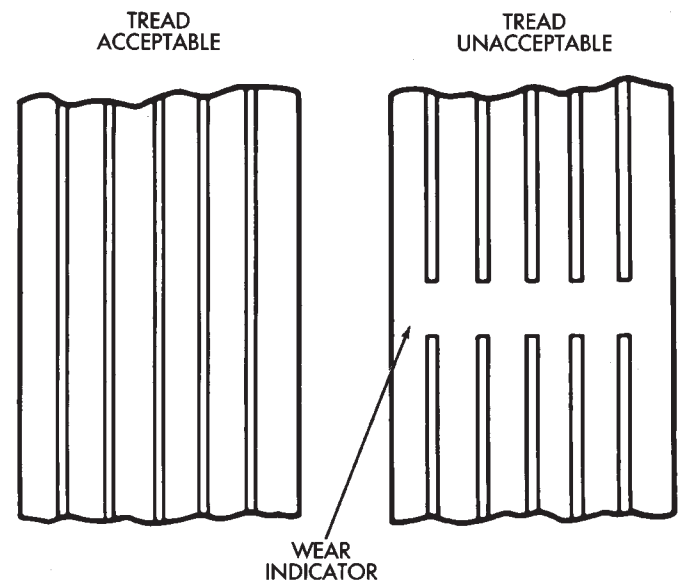

J8922-5

*Fig. 4 Tread Wear Indicators*







**TIRE WEAR PATTERNS**

Under inflation will cause wear on the shoulders of tire. Over inflation will cause wear at the center of tire.

Excessive camber causes the tire to run at an angle to the road. One side of tread is then worn more than the other (Fig. 5).

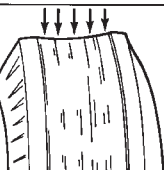
Excessive toe-in or toe-out causes wear on the tread edges and a feathered effect across the tread (Fig. 5).

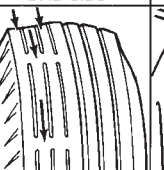
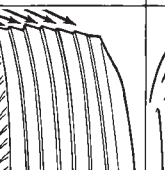
DIAGNOSIS AND TESTING (Continued)

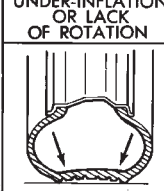
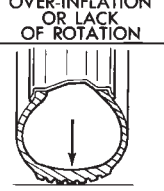
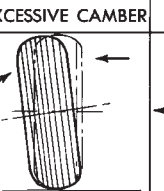
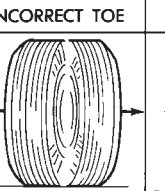
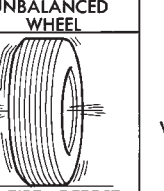
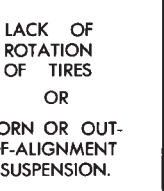
CONDITION	RAPID WEAR AT SHOULDERS	RAPID WEAR AT CENTER	CRACKED TREADS	WEAR ON ONE SIDE	FEATHERED EDGE	BALD SPOTS	SCALLOPED WEAR
EFFECT	 						
CAUSE	UNDER-INFLATION OR LACK OF ROTATION 	OVER-INFLATION OR LACK OF ROTATION 	UNDER-INFLATION OR EXCESSIVE SPEED*	EXCESSIVE CAMBER 	INCORRECT TOE 	UNBALANCED WHEEL 	LACK OF ROTATION OF TIRES OR WORN OR OUT-OF-ALIGNMENT SUSPENSION. 
CORRECTION	ADJUST PRESSURE TO SPECIFICATIONS WHEN TIRES ARE COOL ROTATE TIRES			ADJUST CAMBER TO SPECIFICATIONS	ADJUST TOE-IN TO SPECIFICATIONS	DYNAMIC OR STATIC BALANCE WHEELS	ROTATE TIRES AND INSPECT SUSPENSION SEE GROUP 2

\*HAVE TIRE INSPECTED FOR FURTHER USE.

RN797

Fig. 5 Tire Wear Patterns

TIRE NOISE OR VIBRATION

Radial-ply tires are sensitive to force impulses caused by improper mounting, vibration, wheel defects, or possibly tire imbalance.

To find out if tires are causing the noise or vibration, drive the vehicle over a smooth road at varying speeds. Note the noise level during acceleration and deceleration. The engine, differential and exhaust noises will change as speed varies, while the tire noise will usually remain constant.

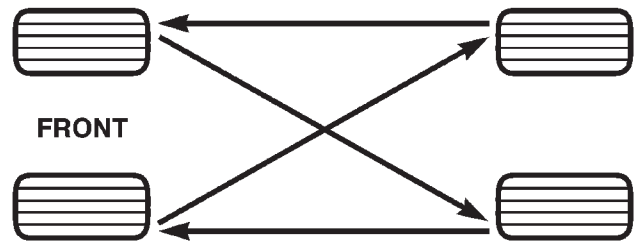

SERVICE PROCEDURES

ROTATION

Tires on the front and rear operate at different loads and perform different steering, driving, and braking functions. For these reasons they wear at unequal rates and tend to develop irregular wear patterns. These effects can be reduced by rotating the tires at regular intervals. The benefits of tire rotation are:

- Increase tread life
- Maintain traction levels
- A smooth, quiet ride

The suggested method of tire rotation is (Fig. 6). Other rotation methods can be used, but they will not provide all the tire longevity benefits.

MATCH MOUNTING

Tires and wheels are currently match mounted at the factory. Match mounting is a technique used to reduce runout in the wheel/tire assembly. This means that the high spot of the tire is aligned with the low spot on the wheel rim. The high spot on the tire is marked with a paint mark or a bright colored adhe-

8031e864

Fig. 6 Tire Rotation Pattern

sive label on the outboard sidewall. The low spot on the rim is identified with a label on the outside of the rim and a dot on the inside of the rim. If the outside label has been removed the tire will have to be removed to locate the dot on the inside of the rim.

Before dismounting a tire from its wheel, a reference mark should be placed on the tire at the valve stem location. This reference will ensure that it is remounted in the original position on the wheel.

(1) Use a dial indicator to locate the high spot of the tire on the center tread rib (Fig. 7). Record the indicator reading and mark the high spot on the tire. Place a mark on the tire at the valve stem location (Fig. 8).

(2) Break down the tire and remount it 180 degrees on the rim (Fig. 9).

(3) Measure the total runout again and mark the tire to indicate the high spot.

(4) If runout is still excessive use the following procedures.

SERVICE PROCEDURES (Continued)

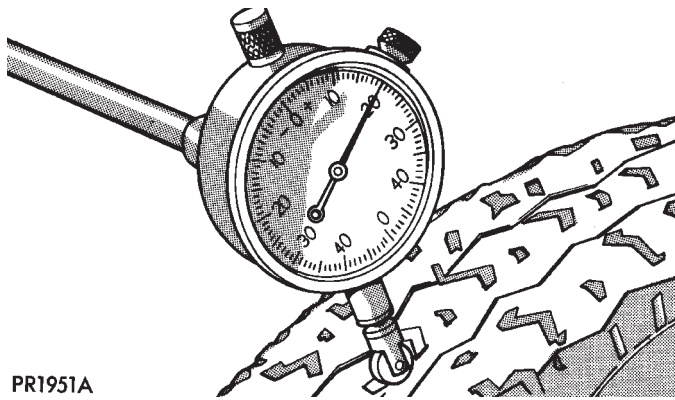

PR1951A

**Fig. 7 Dial Indicator**

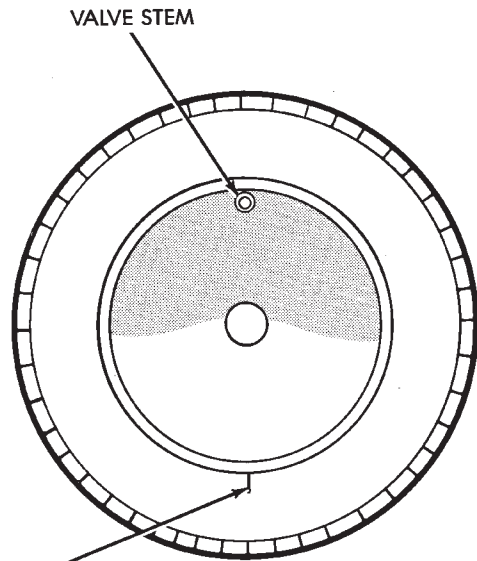

J9322-4

**Fig. 9 Remount Tire 180 Degrees**

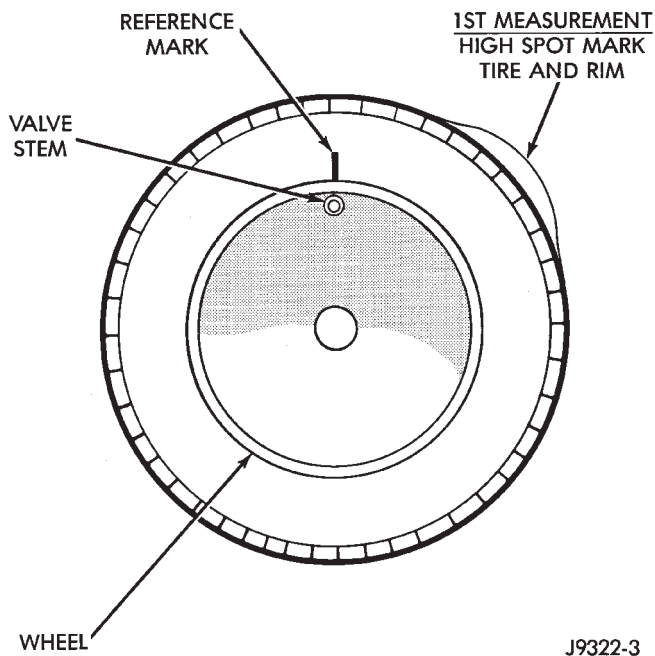

J9322-3

**Fig. 8 First Measurement On Tire**

(a) If the high spot is within 101.6 mm (4.0 in.) of the first spot and is still excessive, replace the tire.

(b) If the high spot is within 101.6 mm (4.0 in.) of the first spot on the wheel, the wheel may be out of specifications. Refer to Wheel and Tire Runout.

(c) If the high spot is NOT within 101.6 mm (4.0 in.) of either high spot, draw an arrow on the tread from second high spot to first. Break down the tire and remount it 90 degrees on rim in that direction (Fig. 10). This procedure will normally reduce the runout to an acceptable amount.

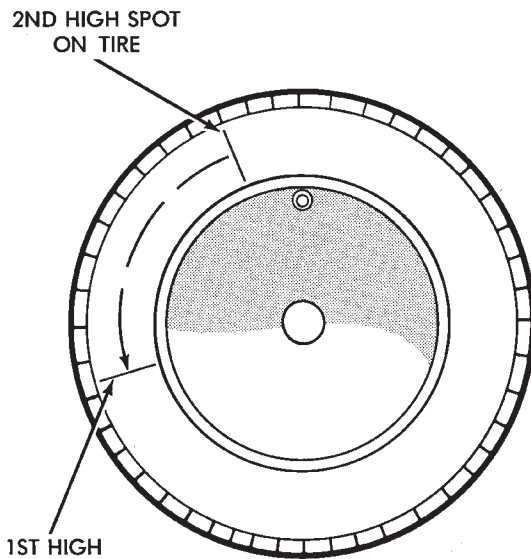

J9322-5

**Fig. 10 Remount Tire 90 Degrees In Direction of Arrow**



## SERVICE PROCEDURES (Continued)

**REPAIRING LEAKS**

For proper repairing, a radial tire must be removed from the wheel. Repairs should only be made if the defect, or puncture, is in the tread area (Fig. 11). The tire should be replaced if the puncture is located in the sidewall.

Deflate tire completely before removing the tire from the wheel. Use lubrication such as a mild soap solution when dismounting or mounting tire. Use tools free of burrs or sharp edges which could damage the tire or wheel rim.

Before mounting tire on wheel, make sure all rust is removed from the rim bead and repaint if necessary.

Install wheel on vehicle, and tighten to proper torque specification.

**CLEANING AND INSPECTION****CLEANING TIRES**

Remove protective coating on tires before delivery of vehicle. This coating may cause deterioration of tires.

To remove the protective coating applying warm water and let it soak for a few minutes. Then scrub the coating away with a soft bristle brush. Steam cleaning may also be used to remove the coating.

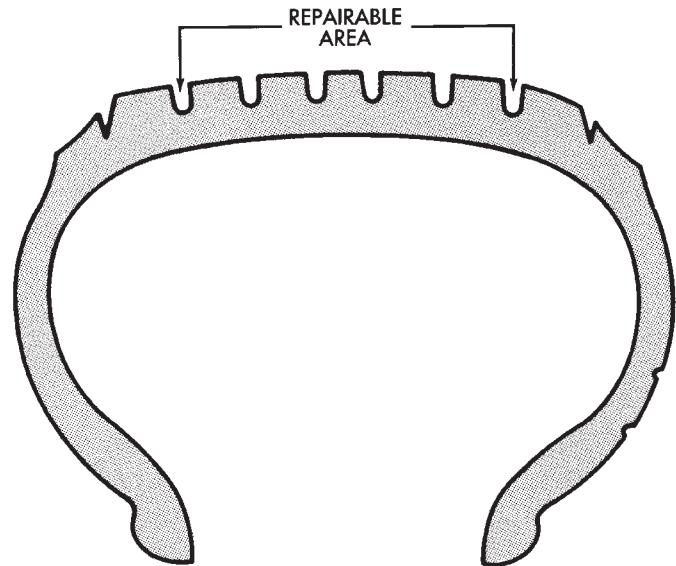

J8922-6

*Fig. 11 Tire Repair Area*

**NOTE: DO NOT** use gasoline, mineral oil, oil-based solvent or wire brush for cleaning.

**SPECIFICATIONS****TIRES**

TIRE SIZE	SUPPLIER
ST P225/75R16	GOODYEAR
LS P245/70R16	GOODYEAR

# WHEELS

## INDEX

	page		page
<b>DESCRIPTION AND OPERATION</b>		<b>SERVICE PROCEDURES</b>	
WHEEL .....	7	TIRE AND WHEEL BALANCE .....	9
<b>DIAGNOSIS AND TESTING</b>		WHEEL INSTALLATION .....	8
TIRE AND WHEEL RUNOUT .....	7	<b>SPECIFICATIONS</b>	
WHEEL INSPECTION .....	7	TORQUE CHART .....	10

## DESCRIPTION AND OPERATION

### WHEEL

The rim size is on the vehicle safety certification label located on the drivers door shut face. The size of the rim is determined by the drivetrain package. Original equipment wheels/rims are designed for operation up to the specified maximum vehicle capacity.

All models use stamped steel, cast aluminum or forged aluminum wheels. Every wheel has raised sections between the rim flanges and rim drop well called safety humps (Fig. 1).

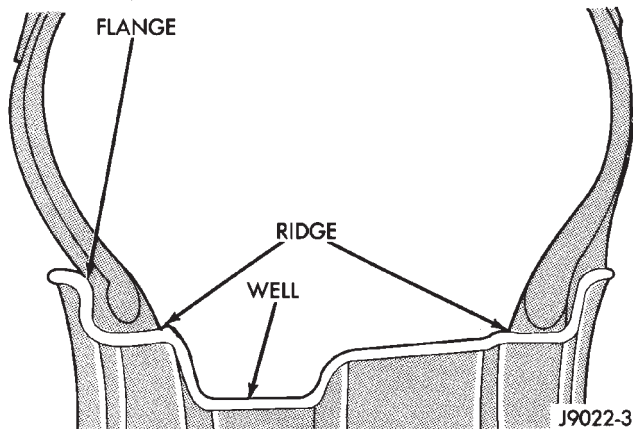

**Fig. 1 Safety Rim**

Initial inflation of the tire forces the bead over these raised sections. In case of rapid loss of air pressure, the raised sections help hold the tire on the wheel.

The wheel studs and nuts are designed for specific applications. All aluminum and some steel wheels have wheel stud nuts with an enlarged nose. This enlarged nose is necessary to ensure proper retention

of the wheels. Do not use replacement studs or nuts with a different design or lesser quality.

## DIAGNOSIS AND TESTING

### WHEEL INSPECTION

Inspect wheels for:

- Excessive run out
- Dents or cracks
- Damaged wheel lug nut holes
- Air Leaks from any area or surface of the rim

**NOTE: Do not attempt to repair a wheel by hammering, heating or welding.**

If a wheel is damaged an original equipment replacement wheel should be used. When obtaining replacement wheels, they should be equivalent in load carrying capacity. The diameter, width, offset, pilot hole and bolt circle of the wheel should be the same as the original wheel.

**WARNING: FAILURE TO USE EQUIVALENT REPLACEMENT WHEELS MAY ADVERSELY AFFECT THE SAFETY AND HANDLING OF THE VEHICLE. USED WHEELS ARE NOT RECOMMENDED. THE SERVICE HISTORY OF THE WHEEL MAY HAVE INCLUDED SEVERE TREATMENT OR VERY HIGH MILEAGE. THE RIM COULD FAIL WITHOUT WARNING.**

### TIRE AND WHEEL RUNOUT

Radial runout is the difference between the high and low points on the tire or wheel (Fig. 2).

Lateral runout is the **wobble** of the tire or wheel.

Radial runout of more than 1.5 mm (.060 inch) measured at the center line of the tread may cause the vehicle to shake.

Lateral runout of more than 2.0 mm (.080 inch) measured near the shoulder of the tire may cause the vehicle to shake.

## DIAGNOSIS AND TESTING (Continued)

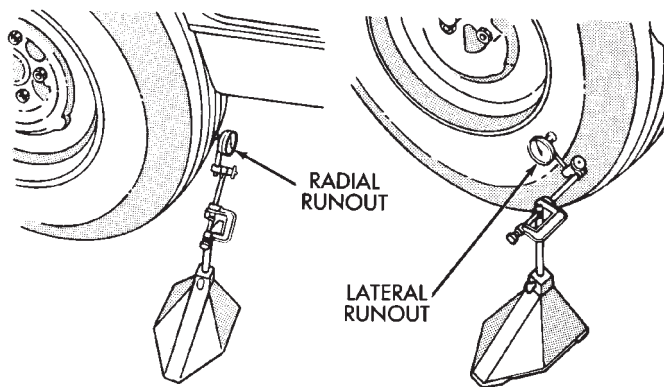

J9022-4

**Fig. 2 Checking Tire/Wheel/Hub Runout**

Sometimes radial runout can be reduced. Relocate the wheel and tire assembly on the mounting studs (See Method 1). If this does not reduce runout to an acceptable level, the tire can be rotated on the wheel. (See Method 2).

**METHOD 1 (RELOCATE WHEEL ON HUB)**

- (1) Drive vehicle a short distance to eliminate tire flat spotting from a parked position.
- (2) Check wheel bearings and adjust if adjustable or replace if necessary.
- (3) Check the wheel mounting surface.
- (4) Relocate wheel on the mounting, two studs over from the original position.
- (5) Tighten wheel nuts until all are properly torqued, to eliminate brake distortion.
- (6) Check radial runout. If still excessive, mark tire sidewall, wheel, and stud at point of maximum runout and proceed to Method 2.

**METHOD 2 (RELOCATE TIRE ON WHEEL)**

**NOTE: Rotating the tire on wheel is particularly effective when there is runout in both tire and wheel.**

- (1) Remove tire from wheel and mount wheel on service dynamic balance machine.
- (2) Check wheel radial runout (Fig. 3) and lateral runout (Fig. 4).
  - STEEL WHEELS: Radial runout 0.040 in., Lateral runout 0.045 in. (maximum)
  - ALUMINUM WHEELS: Radial runout 0.030 in., Lateral runout 0.035 in. (maximum)
- (3) If point of greatest wheel lateral runout is near original chalk mark, remount tire 180 degrees. Recheck runout, Refer to match mounting procedure.

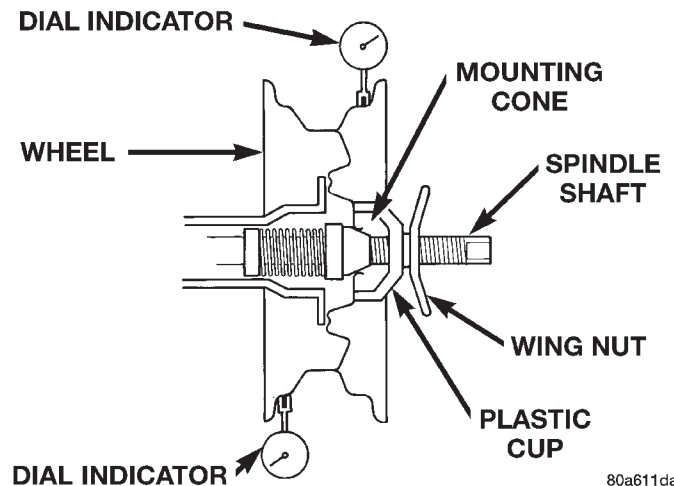

80a611da

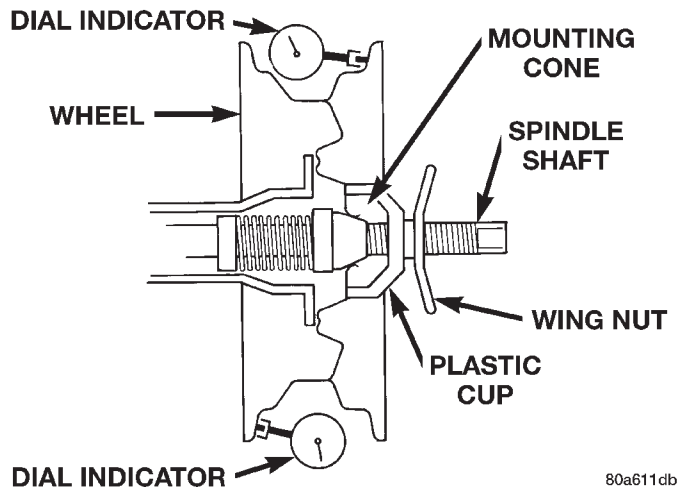
**Fig. 3 Radial Runout****SERVICE PROCEDURES**

80a611db

**Fig. 4 Lateral Runout****WHEEL INSTALLATION**

The wheel studs and nuts are designed for specific applications. They must be replaced with equivalent parts. Do not use replacement parts of lesser quality or a substitute design. All aluminum and some steel wheels have wheel stud nuts which feature an enlarged nose. This enlarged nose is necessary to ensure proper retention of the aluminum wheels.

**NOTE: Do not use chrome plated lug nuts with chrome plated wheels.**

Before installing the wheel, be sure to remove any build up of corrosion on the wheel mounting surfaces. Ensure wheels are installed with good metal-to-metal contact. Improper installation could cause loosening of wheel nuts. This could affect the safety and handling of your vehicle.

To install the wheel, first position it properly on the mounting surface. All wheel nuts should then be



## SERVICE PROCEDURES (Continued)

tightened just snug. Gradually tighten them in sequence to the proper torque specification (Fig. 5). **Never use oil or grease on studs or nuts.**

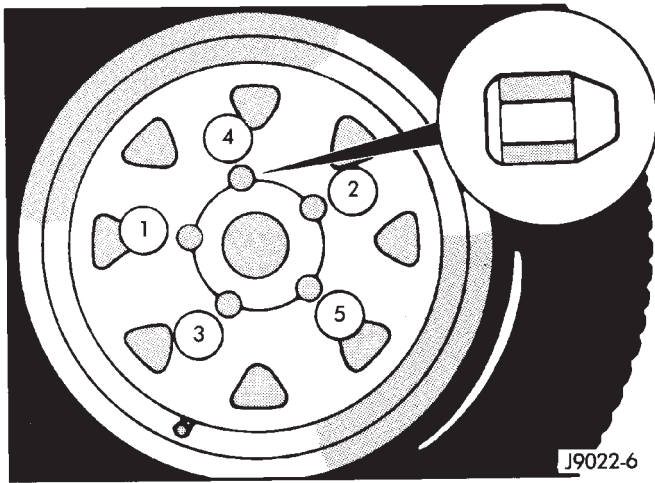

*Fig. 5 Lug Nut Tightening Pattern*

## WHEEL REPLACEMENT

Wheels must be replaced if they have:

- Excessive runout
- Bent or dented
- Leak air through welds
- Have damaged bolt holes

Wheel repairs employing hammering, heating, or welding are not allowed.

Original equipment wheels are available through your dealer. Replacement wheels from any other source should be equivalent in:

- Load carrying capacity
- Diameter
- Width
- Offset
- Mounting configuration

Failure to use equivalent replacement wheels may affect the safety and handling of your vehicle. Replacement with **used** wheels is not recommended. Their service history may have included severe treatment.

## TIRE AND WHEEL BALANCE

It is recommended that a two plane service dynamic balancer be used when a tire and wheel assembly require balancing. Refer to balancer operation instructions for proper cone mounting procedures. Typically use front cone mounting method for steel wheels. For aluminum wheel use back cone mounting method without cone spring.

**NOTE:** Static should be used only when a two plane balancer is not available.

**NOTE:** Cast aluminum and forged aluminum wheels require coated balance weights and special alignment equipment.

Wheel balancing can be accomplished with either on or off vehicle equipment. When using on-vehicle balancing equipment, remove the opposite wheel/tire. Off-vehicle balancing is recommended.

For static balancing, find location of heavy spot causing the imbalance. Counter balance wheel directly opposite the heavy spot. Determine weight required to counter balance the area of imbalance. Place half of this weight on the **inner** rim flange and the other half on the **outer** rim flange (Fig. 6).

For dynamic balancing, the balancing equipment is designed to locate the amount of weight to be applied to both the inner and outer rim flange (Fig. 7).

SERVICE PROCEDURES (Continued)

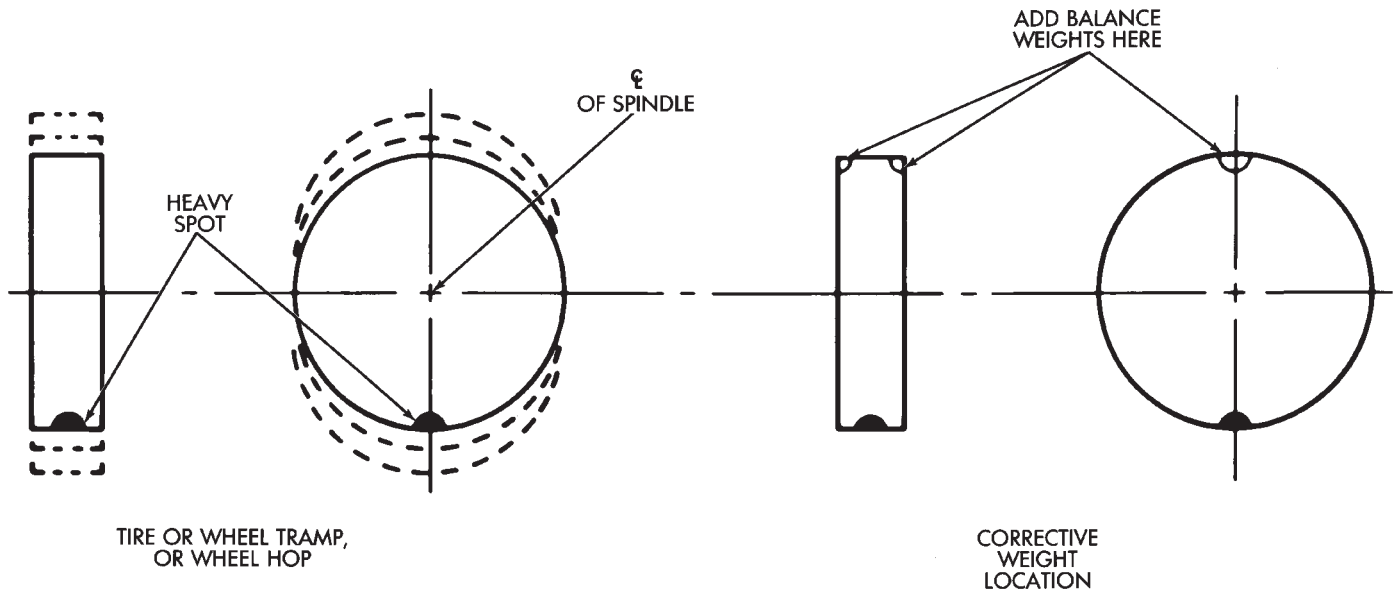

J8922-8

Fig. 6 Static Unbalance & Balance

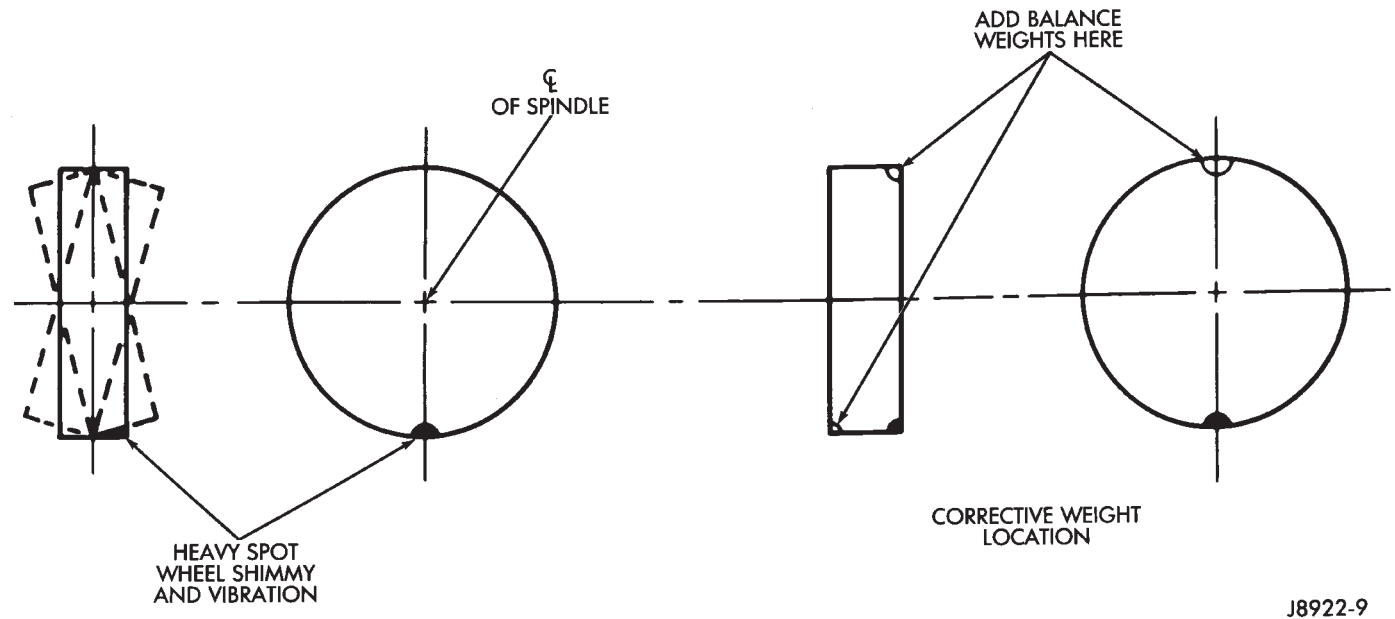

J8922-9

Fig. 7 Dynamic Unbalance & Balance

SPECIFICATIONS

TORQUE CHART

DESCRIPTION	TORQUE
<b>Lug Nut</b>	
1/2 X 20 with 60° Cone . . . . .	115-150 N·m (85-115 ft. lbs.)