

# LUBRICATION AND MAINTENANCE

## TABLE OF CONTENTS

	page		page
LUBRICANTS .....	1	JUMP STARTING, TOWING AND HOISTING .....	9
MAINTENANCE SCHEDULES .....	4		

## LUBRICANTS

### TABLE OF CONTENTS

	page		page
<b>SERVICE PROCEDURES</b>		CLASSIFICATION OF LUBRICANTS.....	1
PARTS AND LUBRICANT		<b>SPECIFICATIONS</b>	
RECOMMENDATIONS .....	1	FLUID CAPACITIES .....	3
INTERNATIONAL SYMBOLS .....	1		

### SERVICE PROCEDURES

#### PARTS AND LUBRICANT RECOMMENDATIONS

##### RECOMMENDATIONS

When service is required, DaimlerChrysler Corporation recommends that only Mopar® brand parts, lubricants and chemicals be used. Mopar provides the best engineered products for servicing DaimlerChrysler Corporation vehicles.

##### INTERNATIONAL SYMBOLS

DaimlerChrysler Corporation uses international symbols to identify engine compartment lubricant and fluid inspection and fill locations (Fig. 1).

##### CLASSIFICATION OF LUBRICANTS

Only lubricants bearing designations defined by the following organization should be used to service a DaimlerChrysler Corporation vehicle.

- Society of Automotive Engineers (SAE)
- American Petroleum Institute (API) (Fig. 2)
- National Lubricating Grease Institute (NLGI) (Fig. 3)

<b>CHRYSLER CORPORATION</b>			
	ENGINE OIL		BRAKE FLUID
	AUTOMATIC TRANSMISSION FLUID		POWER STEERING FLUID
	ENGINE COOLANT		WINDSHIELD WASHER FLUID

9500-1

**Fig. 1 International Symbols**

### ENGINE OIL

#### SAE VISCOSITY RATING INDICATES ENGINE OIL VISCOSITY

An SAE viscosity grade is used to specify the viscosity of engine oil. SAE 30 specifies a single viscosity engine oil. Engine oils also have multiple viscosities. These are specified with a dual SAE viscosity grade which indicates the cold-to-hot temperature viscosity range.

- SAE 30 = single grade engine oil.
- SAE 10W-30 = multiple grade engine oil.

DaimlerChrysler Corporation only recommends multiple grade engine oils.

SERVICE PROCEDURES (Continued)

API QUALITY CLASSIFICATION

This symbol (Fig. 2) on the front of an oil container means that the oil has been certified by the American Petroleum Institute (API) to meet all the lubrication requirements specified by DaimlerChrysler Corporation.

Refer to Group 9, Engine for gasoline engine oil specification.



9400-9

Fig. 2 API Symbol

GEAR LUBRICANTS

SAE ratings also apply to multiple grade gear lubricants. In addition, API classification defines the lubricants usage.

LUBRICANTS AND GREASES

Lubricating grease is rated for quality and usage by the NLGI. All approved products have the NLGI symbol (Fig. 3) on the label. At the bottom NLGI symbol is the usage and quality identification letters. Wheel bearing lubricant is identified by the letter "G". Chassis lubricant is identified by the letter "L". The letter following the usage letter indicates the quality of the lubricant. The following symbols indicate the highest quality.

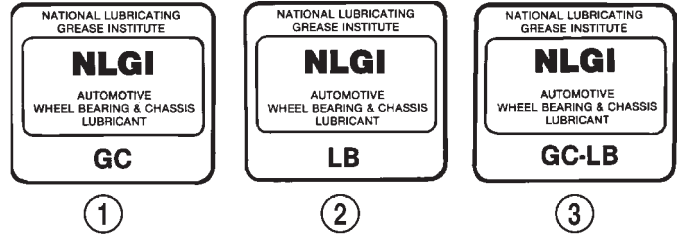

9200-7

Fig. 3 NLGI Symbol

- 1 - WHEEL BEARINGS
- 2 - CHASSIS LUBRICATION
- 3 - CHASSIS AND WHEEL BEARINGS

## SPECIFICATIONS

### FLUID CAPACITIES

#### FUEL TANK

All ..... 76.4 L (20.2 gal.)

#### ENGINE OIL W/FILTER CHANGE

2.5L ..... 3.8 L (4.0 qts.)

4.0L ..... 5.7 L (6.0 qts.)

#### COOLING SYSTEM

2.5L ..... 9.5 L (10 qts.)\*

4.0L ..... 11.4 L (12 qts.)\*\*

\*Includes 2.2 L (2.3 qts) for coolant recovery reservoir.

\*\*Includes 0.9 L (1.0 qt) for coolant recovery reservoir.

#### AUTOMATIC TRANSMISSION

Dry fill capacity\*

AW4 ..... 7.8 L (16.5 pts.)

30RH ..... 4.67 L (9.86pts.)

\*Depending on type and size of internal cooler, length and inside diameter of cooler lines, or use of an auxiliary cooler, these figures may vary. Refer to Group 21, Transmission for proper fluid fill procedure.

## MANUAL TRANSMISSION

AX5 (4X2) ..... 3.5 L (3.7 qts.)

AX5 (4X4) ..... 3.3 L (3.5 qts.)

AX15 (4X2) ..... 3.15 L (3.3 qts.)

AX15 (4X4) ..... 3.15 L (3.3 qts.)

## TRANSFER CASE

SELEC-TRAC 242 ..... 1.3 L (2.85 pts.)

COMMAND-TRAC 231 ..... 1.0 L (2.2 pts.)

## FRONT AXLE

181-FBI ..... 1.48 L (3.13 pts.)

186-FBI ..... 1.18L (2.5pts.)

## REAR AXLE

194-RBI ..... 1.66 L (3.5 pts.)\*

8-1/4 ..... 2.08 L (4.4 pts.\*\*)

\* When equipped with TRAC-LOK, include 3.5 ounces of Friction Modifier Additive.

\*\* When equipped with TRAC-LOK, include 4 ounces of Friction Modifier Additive.

## POWER STEERING

Power steering fluid capacities are dependent on engine/chassis options as well as steering gear/cooler options. Depending on type and size of internal cooler, length and inside diameter of cooler lines, or use of an auxiliary cooler, these capacities may vary. Refer to Section 19 of the service manual for proper fill and bleed procedures.

# MAINTENANCE SCHEDULES

## TABLE OF CONTENTS

	page	page
<b>SERVICE PROCEDURES</b>		
DESCRIPTION . . . . .	4	UNSCHEDULED INSPECTION . . . . . 4

### SERVICE PROCEDURES

#### DESCRIPTION

Service and maintenance procedures for components and systems listed in Schedule "A" or "B" can be found by using the Group Tab Locator index at the front of this manual. If it is not clear which group contains the information needed, refer to the index at the back of this manual.

There are two maintenance schedules that show proper service based on the conditions that the vehicle is subjected to.

Schedule "A", lists scheduled maintenance to be performed when the vehicle is used for general transportation.

Schedule "B", lists maintenance intervals for vehicles that are operated under the conditions listed at the beginning of that schedule section.

Use the schedule that best describes the driving conditions.

Where time and mileage are listed, follow the interval that occurs first.

#### UNSCHEDULED INSPECTION

##### *At Each Stop For Fuel*

- Check engine oil level, add as required.
- Check windshield washer solvent and add if required.

##### *Once A Month*

- Check tire pressure and look for unusual wear or damage.
- Inspect battery and clean and tighten terminals as required. Check electrolyte level and add water as needed.
- Check fluid levels of coolant reservoir, power steering, brake master cylinder, and transmission and add as needed.
- Check all lights and all other electrical items for correct operation.

##### *At Each Oil Change*

- Inspect exhaust system.
- Inspect brake hoses.

- Rotate the tires at each oil change interval shown on Schedule "A" (7,500 miles) or every other interval shown on Schedule "B" (6,000 miles).
- Check coolant level, hoses, and clamps.
- After completion of off-road operation, the underside of the vehicle should be thoroughly inspected. Examine threaded fasteners for looseness.

#### EMISSION CONTROL SYSTEM MAINTENANCE

The scheduled emission maintenance listed in **bold type** on the Maintenance Schedules, must be done at the mileage specified to assure the continued proper functioning of the emission control system. These, and all other maintenance services included in this manual, should be done to provide the best vehicle performance and reliability. More frequent maintenance may be needed for vehicles in severe operating conditions such as dusty areas and very short trip driving.

#### FLUID FILL LOCATIONS AND LUBRICATION POINTS

The fluid fill/check locations and lubrication points are located in each applicable group.

#### SCHEDULE "A"

##### **7,500 Miles (12 000 km) or at 6 months**

- Change engine oil.
- Replace engine oil filter.
- Lubricate steering linkage (4x4 only).

##### **15,000 Miles (24 000 km) or at 12 months**

- Change engine oil.
- Replace engine oil filter.
- Lubricate steering linkage.
- Lubricate steering and suspension ball joints.

##### **22,500 Miles (36 000 km) or at 18 months**

- Change engine oil.
- Replace engine oil filter.
- Inspect brake linings.
- Lubricate steering linkage (4x4 only).

## SERVICE PROCEDURES (Continued)

**30,000 Miles (48 000 km) or at 24 months**

- Change engine oil.
- Replace engine oil filter.
- **Replace air cleaner element.**
- **Replace spark plugs.**
- Inspect drive belt, adjust tension as necessary.
- Lubricate steering linkage.
- Drain and refill automatic transmission fluid.
- Drain and refill transfer case fluid.
- Lubricate steering and suspension ball joints.

**37,500 Miles (60 000 km) or at 30 months**

- Change engine oil.
- Replace engine oil filter.
- Lubricate steering linkage (4x4 only).
- Drain and refill manual transmission fluid.

**45,000 Miles (72 000 km) or at 36 months**

- Change engine oil.
- Replace engine oil filter.
- Lubricate steering linkage.
- Inspect brake linings.
- Flush and replace engine coolant at 36 months, regardless of mileage.
- Lubricate steering and suspension ball joints.

**52,500 Miles (84 000 km) or at 42 months**

- Change engine oil.
- Replace engine oil filter.
- Flush and replace engine coolant if not done at 36 months.
- Lubricate steering linkage (4x4 only).

**60,000 Miles (96 000 km) or at 48 months**

- Change engine oil.
- Replace engine oil filter.
- **Replace engine air cleaner element.**
- **Replace ignition cables.**
- **Replace spark plugs.**
- Inspect drive belt, adjust tension as necessary.
- Lubricate steering linkage.
- Drain and refill automatic transmission fluid.
- Drain and refill transfer case fluid.
- Lubricate steering and suspension ball joints.

**67,500 Miles (108 000 km) or at 54 months**

- Change engine oil.
- Replace engine oil filter.
- Inspect brake linings.
- Lubricate steering linkage (4x4 only).

**75,000 Miles (120 000 km) or at 60 months**

- Change engine oil.
- Replace engine oil filter.
- Lubricate steering linkage.

- Flush and replace engine coolant if it has been 30,000 miles (48 000 km) or 24 months since last change.

- Lubricate steering and suspension ball joints.
- Drain and refill manual transmission fluid.

**82,500 Miles (133 000 km) or at 66 months**

- Change engine oil.
- Replace engine oil filter.
- Flush and replace engine coolant if it has been 30,000 miles (48 000 km) or 24 months since last change.

- Lubricate steering linkage (4x4 only).

**90,000 Miles (144 000 km) or at 72 months**

- Change engine oil.
- Replace engine oil filter.
- **Replace engine air cleaner element.**
- **Replace spark plugs.**
- Inspect drive belt, adjust tension as necessary.
- Lubricate steering linkage.
- Drain and refill automatic transmission fluid.
- Drain and refill transfer case fluid.
- Inspect brake linings.
- Lubricate steering and suspension ball joints.

**97,500 Miles (156 000 km) or at 78 months**

- Change engine oil.
- Replace engine oil filter.
- Lubricate steering linkage (4x4 only).

**105,000 Miles (168 000 km) or at 84 months**

- Change engine oil.
- Replace engine oil filter.
- Lubricate steering linkage.
- Flush and replace engine coolant if it has been 30,000 miles (48 000 km) or 24 months since last change.
- Lubricate steering and suspension ball joints.

**112,500 Miles (180 000 km) or at 90 months**

- Change engine oil.
- Replace engine oil filter.
- Inspect brake linings.
- Flush and replace engine coolant if it has been 30,000 miles (48 000 km) or 24 months since last change.
- Lubricate steering linkage (4x4 only).
- Drain and refill manual transmission fluid.

**120,000 Miles (192 000 km) or at 96 months**

- Change engine oil.
- Replace engine oil filter.
- **Replace engine air cleaner element.**
- **Replace ignition cables.**
- **Replace spark plugs.**
- Inspect drive belt, adjust tension as necessary.

## SERVICE PROCEDURES (Continued)

- Lubricate steering linkage.
- Drain and refill automatic transmission fluid.
- Drain and refill transfer case fluid.
- Lubricate steering and suspension ball joints.

**Important:** Inspection and service should also be performed any time a malfunction is observed or suspected.

**SCHEDULE "B"**

Follow Schedule "B" if the vehicle is usually operated under one or more of the following conditions.

- Frequent short trips driving less than 5 miles (8 km).
- Frequent driving in dusty conditions.
- Frequent trailer towing.
- Extensive idling.
- More than 50% of driving is at sustained high speeds during hot weather, above 90°F (32°C).
- Off-road driving.
- Desert operation.

**3,000 Miles (5 000 km)**

- Change engine oil.
- Replace engine oil filter.
- Lubricate steering linkage.

**6,000 Miles (10 000 km)**

- Change engine oil.
- Replace engine oil filter.
- Lubricate steering linkage.
- Lubricate steering and suspension ball joints.

**9,000 Miles (14 000 km)**

- Change engine oil.
- Replace engine oil filter.
- Lubricate steering linkage.

**12,000 Miles (19 000 km)**

- Change engine oil.
- Replace engine oil filter.
- Lubricate steering linkage.
- Drain and refill automatic transmission fluid.
- Drain and refill front and rear axles.‡
- Inspect brake linings.
- Lubricate steering and suspension ball joints.

**15,000 Miles (24 000 km)**

- Change engine oil.
- Replace engine oil filter.
- **Inspect engine air cleaner element, replace as necessary.**
- Lubricate steering linkage.

**18,000 Miles (29 000 km)**

- Change engine oil.
- Replace engine oil filter.
- Lubricate steering linkage.

- Lubricate steering and suspension ball joints.
- Drain and refill manual transmission fluid.

**21,000 Miles (34 000 km)**

- Change engine oil.
- Replace engine oil filter.
- Lubricate steering linkage.

**24,000 Miles (38 000 km)**

- Change engine oil.
- Replace engine oil filter.
- Lubricate steering linkage.
- Drain and refill automatic transmission fluid.
- Drain and refill front and rear axles.‡
- Inspect brake linings.
- Lubricate steering and suspension ball joints.

**27,000 Miles (43 000 km)**

- Change engine oil.
- Replace engine oil filter.
- Lubricate steering linkage.

**30,000 Miles (48 000 km)**

- Change engine oil.
- Replace engine oil filter.
- **Replace engine air cleaner element.**
- **Replace spark plugs.**
- Inspect drive belt, adjust tension as necessary.
- Lubricate steering linkage.
- Drain and refill transfer case fluid.
- Lubricate steering and suspension ball joints.

**33,000 Miles (53 000 km)**

- Change engine oil.
- Replace engine oil filter.
- Lubricate steering linkage.

**36,000 Miles (58 000 km)**

- Change engine oil.
- Replace engine oil filter.
- Lubricate steering linkage.
- Drain and refill automatic transmission fluid.
- Drain and refill front and rear axles.‡
- Inspect brake linings.
- Lubricate steering and suspension ball joints.
- Drain and refill manual transmission fluid.

**39,000 Miles (62 000 km)**

- Change engine oil.
- Replace engine oil filter.
- Lubricate steering linkage.

**42,000 Miles (67 000 km)**

- Change engine oil.
- Replace engine oil filter.
- Lubricate steering linkage.
- Lubricate steering and suspension ball joints.

## SERVICE PROCEDURES (Continued)

**45,000 Miles (72 000 km)**

- Change engine oil.
- Replace engine oil filter.
- **Inspect engine air cleaner element, replace as necessary.**
- Lubricate steering linkage.

**48,000 Miles (77 000 km)**

- Change engine oil.
- Replace engine oil filter.
- Lubricate steering linkage.
- Drain and refill automatic transmission fluid.
- Drain and refill front and rear axles.‡
- Inspect brake linings.
- Lubricate steering and suspension ball joints.

**51,000 Miles (82 000 km)**

- Change engine oil.
- Replace engine oil filter.
- Flush and replace engine coolant.
- Lubricate steering linkage.

**54,000 Miles (86 000 km)**

- Change engine oil.
- Replace engine oil filter.
- Lubricate steering linkage.
- Lubricate steering and suspension ball joints.
- Drain and refill manual transmission fluid.

**57,000 Miles (91 000 km)**

- Change engine oil.
- Replace engine oil filter.
- Lubricate steering linkage.

**60,000 Miles (96 000 km)**

- Change engine oil.
- Replace engine oil filter.
- **Replace engine air cleaner element.**
- **Replace ignition cables.**
- **Replace spark plugs.**
- Inspect drive belt, adjust tension as necessary.
- Lubricate steering linkage.
- Drain and refill automatic transmission fluid.
- Drain and refill transfer case fluid.
- Drain and refill front and rear axles.‡
- Inspect brake linings.
- Lubricate steering and suspension ball joints.

**63,000 Miles (101 000 km)**

- Change engine oil.
- Replace engine oil filter.
- Lubricate steering linkage.

**66,000 Miles (106 000 km)**

- Change engine oil.
- Replace engine oil filter.
- Lubricate steering linkage.
- Lubricate steering and suspension ball joints.

**69,000 Miles (110 000 km)**

- Change engine oil.
- Replace engine oil filter.
- Lubricate steering linkage.

**72,000 Miles (115 000 km)**

- Change engine oil.
- Replace engine oil filter.
- Lubricate steering linkage.
- Drain and refill automatic transmission fluid.
- Drain and refill front and rear axles.‡
- Inspect brake linings.
- Lubricate steering and suspension ball joints.
- Drain and refill manual transmission fluid.

**75,000 Miles (120 000 km)**

- Change engine oil.
- Replace engine oil filter.
- **Inspect engine air cleaner element, replace as necessary.**
- Lubricate steering linkage.

**78,000 Miles (125 000 km)**

- Change engine oil.
- Replace engine oil filter.
- Lubricate steering linkage.
- Lubricate steering and suspension ball joints.

**81,000 Miles (130 000 km)**

- Change engine oil.
- Replace engine oil filter.
- Flush and replace engine coolant if it has been 30,000 miles (48 000 km) since last change.
- Lubricate steering linkage.

**84,000 Miles (134 000 km)**

- Change engine oil.
- Replace engine oil filter.
- Lubricate steering linkage.
- Drain and refill automatic transmission fluid.
- Drain and refill front and rear axles.‡
- Inspect brake linings.
- Lubricate steering and suspension ball joints.

## SERVICE PROCEDURES (Continued)

**87,000 Miles (139 000 km)**

- Change engine oil.
- Replace engine oil filter.
- Lubricate steering linkage.

**90,000 Miles (144 000 km)**

- Change engine oil.
- Replace engine oil filter.
- **Replace engine air cleaner element.**
- **Replace spark plugs.**
- Inspect drive belt, adjust tension as necessary.
- Lubricate steering linkage.
- Drain and refill transfer case fluid.
- Lubricate steering and suspension ball joints.
- Drain and refill manual transmission fluid.

**93,000 Miles (149 000 km)**

- Change engine oil.
- Replace engine oil filter.
- Lubricate steering linkage.

**96,000 Miles (154 000 km)**

- Change engine oil.
- Replace engine oil filter.
- Lubricate steering linkage.
- Drain and refill automatic transmission fluid.
- Drain and refill front and rear axles.‡
- Inspect brake linings.
- Lubricate steering and suspension ball joints.

**99,000 Miles (158 000 km)**

- Change engine oil.
- Replace engine oil filter.
- Lubricate steering linkage.

**102,000 Miles (163 000 km)**

- Change engine oil.
- Replace engine oil filter.
- Lubricate steering linkage.
- Lubricate steering and suspension ball joints.

**105,000 Miles (168 000 km)**

- Change engine oil.
- Replace engine oil filter.
- **Inspect engine air cleaner element, replace as necessary.**
- Lubricate steering linkage.

**108,000 Miles (173 000 km)**

- Change engine oil.
- Replace engine oil filter.

- Lubricate steering linkage.
- Drain and refill automatic transmission fluid.
- Drain and refill front and rear axles.‡
- Inspect brake linings.
- Lubricate steering and suspension ball joints.
- Drain and refill manual transmission fluid.

**111,000 Miles (178 000 km)**

- Change engine oil.
- Replace engine oil filter.
- Flush and replace engine coolant if it has been 30,000 miles (48 000 km) since last change.
- Lubricate steering linkage.

**114,000 Miles (182 000 km)**

- Change engine oil.
- Replace engine oil filter.
- Lubricate steering linkage.
- Lubricate steering and suspension ball joints.

**117,000 Miles (187 000 km)**

- Change engine oil.
- Replace engine oil filter.
- Lubricate steering linkage.

**120,000 Miles (192 000 km)**

- Change engine oil.
  - Replace engine oil filter.
  - **Replace engine air cleaner element.**
  - **Replace ignition cables.**
  - **Replace spark plugs.**
  - Inspect drive belt, adjust tension as necessary.
  - Lubricate steering linkage.
  - Drain and refill automatic transmission fluid.
  - Drain and refill transfer case fluid.
  - Drain and refill front and rear axles.‡
  - Inspect brake linings.
  - Lubricate steering and suspension ball joints.
- ‡Off-highway operation, trailer towing, taxi, limousine, bus, snow plowing, or other types of commercial service or prolonged operation with heavy loading, especially in hot weather, require front and rear axle service indicated with a ‡ in Schedule "B". Perform these services if the vehicle is usually operated under these conditions.

**Important:** Inspection and service should also be performed any time a malfunction is observed or suspected.



# JUMP STARTING, TOWING AND HOISTING

## TABLE OF CONTENTS

	page		page
<b>SERVICE PROCEDURES</b>		<b>FOUR-WHEEL-DRIVE VEHICLE TOWING</b> . . . . .	10
JUMP STARTING PROCEDURE . . . . .	9	<b>EMERGENCY TOW HOOKS</b> . . . . .	11
TWO-WHEEL-DRIVE VEHICLE TOWING . . . . .	10	<b>HOISTING RECOMMENDATIONS</b> . . . . .	11

## SERVICE PROCEDURES

### JUMP STARTING PROCEDURE

**WARNING: REVIEW ALL SAFETY PRECAUTIONS AND WARNINGS IN GROUP 8A, BATTERY/STARTING/CHARGING SYSTEMS DIAGNOSTICS. DO NOT JUMP START A FROZEN BATTERY, PERSONAL INJURY CAN RESULT. DO NOT JUMP START WHEN MAINTENANCE FREE BATTERY INDICATOR DOT IS YELLOW OR BRIGHT COLOR. DO NOT JUMP START A VEHICLE WHEN THE BATTERY FLUID IS BELOW THE TOP OF LEAD PLATES. DO NOT ALLOW JUMPER CABLE CLAMPS TO TOUCH EACH OTHER WHEN CONNECTED TO A BOOSTER SOURCE. DO NOT USE OPEN FLAME NEAR BATTERY. REMOVE METALLIC JEWELRY WORN ON HANDS OR WRISTS TO AVOID INJURY BY ACCIDENTAL ARCING OF BATTERY CURRENT. WHEN USING A HIGH OUTPUT BOOSTING DEVICE, DO NOT ALLOW BATTERY VOLTAGE TO EXCEED 16 VOLTS. REFER TO INSTRUCTIONS PROVIDED WITH DEVICE BEING USED.**

**CAUTION: When using another vehicle as a booster, do not allow vehicles to touch. Electrical systems can be damaged on either vehicle.**

#### TO JUMP START A DISABLED VEHICLE:

- (1) Raise hood on disabled vehicle and visually inspect engine compartment for:
- Battery cable clamp condition, clean if necessary.
  - Frozen battery.
  - Yellow or bright color test indicator, if equipped.
  - Low battery fluid level.
  - Generator drive belt condition and tension.
  - Fuel fumes or leakage, correct if necessary.

**CAUTION: If the cause of starting problem on disabled vehicle is severe, damage to booster vehicle charging system can result.**

(2) When using another vehicle as a booster source, turn off all accessories, place gear selector in park or neutral, set park brake and operate engine at 1200 rpm.

(3) On disabled vehicle, place gear selector in park or neutral and set park brake. Turn off all accessories.

(4) Connect jumper cables to booster battery. RED clamp to positive terminal (+). BLACK clamp to negative terminal (-). DO NOT allow clamps at opposite end of cables to touch, electrical arc will result. Review all warnings in this procedure.

(5) On disabled vehicle, connect RED jumper cable clamp to positive (+) terminal. Connect BLACK jumper cable clamp to engine ground as close to the ground cable attaching point as possible (Fig. 1).

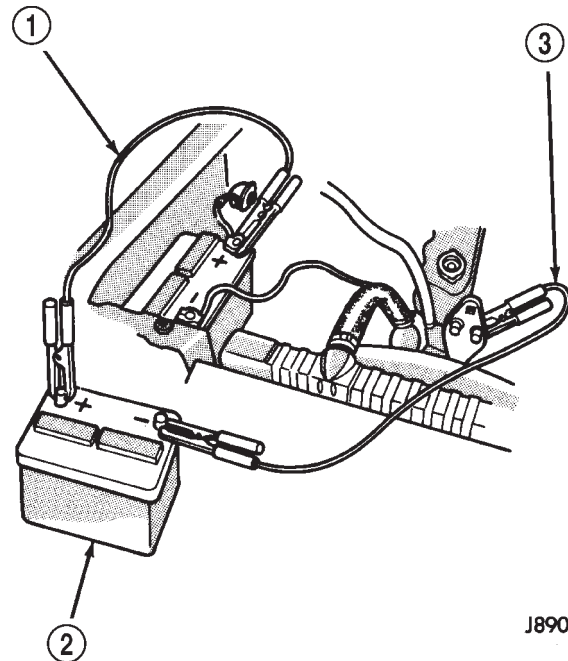

J8900-7

**Fig. 1 Jumper Cable Connections—Typical**

- 1 - POSITIVE CABLE CONNECTION
- 2 - BOOSTER BATTERY
- 3 - NEGATIVE OR GROUND CABLE CONNECTION

## SERVICE PROCEDURES (Continued)

**CAUTION:** Do not crank starter motor on disabled vehicle for more than 15 seconds, starter will over-heat and could fail.

(6) Allow battery in disabled vehicle to charge to at least 12.4 volts (75% charge) before attempting to start engine. If engine does not start within 15 seconds, stop cranking engine and allow starter to cool (15 min.), before cranking again.

## DISCONNECT CABLE CLAMPS AS FOLLOWS:

- Disconnect BLACK cable clamp from engine ground on disabled vehicle.
- When using a Booster vehicle, disconnect BLACK cable clamp from battery negative terminal. Disconnect RED cable clamp from battery positive terminal.
- Disconnect RED cable clamp from battery positive terminal on disabled vehicle.

## TWO-WHEEL-DRIVE VEHICLE TOWING

## TOWING-REAR END LIFTED (SLING-TYPE)

**WARNING: WHEN TOWING A DISABLED VEHICLE AND THE DRIVE WHEELS ARE SECURED IN A WHEEL LIFT OR TOW DOLLIES, ENSURE THE TRANSMISSION IS IN THE PARK POSITION (AUTOMATIC TRANSMISSION) OR A FORWARD DRIVE GEAR (MANUAL TRANSMISSION).**

**CAUTION:** Do not use steering column lock to secure steering wheel during towing operation.

2WD XJ vehicles can be towed with the front wheels on the surface for extended distances at speeds not exceeding 48 km/h (30 mph). If the vehicle is equipped with a factory installed trailer tow package, use a SAE approved wheel lift device.

- (1) Attach J-hooks around the axle shaft tube outboard of the shock absorber.
- (2) Place the sling crossbar under and forward of the bumper.
- (3) Attach safety chains around the frame rails.
- (4) Turn the ignition switch to the OFF position to unlock the steering wheel.
- (5) Secure steering wheel in the straight ahead position with a clamp device designed for towing.
- (6) Verify that steering components are in good condition.
- (7) Shift the transmission to NEUTRAL.

## TOWING-REAR END LIFTED (WHEEL LIFT)

- (1) Raise front of vehicle off ground and install tow dollies under front wheels.
- (2) Attach wheel lift to rear wheels.
- (3) Place transmission in neutral.
- (4) Raise vehicle to towing height.
- (5) Place transmission in park (automatic transmission) or first gear (manual transmission).

## TOWING-FRONT END LIFTED

To prevent damage to front fascia components, use only a Wheel-Lift type towing device or Flat-Bed hauling equipment.

If using the wheel-lift towing method:

- (1) Raise rear of vehicle off ground and install tow dollies under rear wheels.
- (2) Attach wheel lift to front wheels.
- (3) Place transmission in neutral.
- (4) Raise vehicle to towing height.
- (5) Place transmission in park (automatic transmission) or first gear (manual transmission).

## FOUR-WHEEL-DRIVE VEHICLE TOWING

DaimlerChrysler Corporation recommends that a 4WD vehicle be transported on a flat bed device. A wheel lift or sling type device can be used provided all wheels are lifted off the ground using tow dollies.

If the vehicle is equipped with a factory installed trailer tow package, use a SAE approved wheel lift device.

**WARNING: WHEN TOWING A DISABLED VEHICLE AND THE DRIVE WHEELS ARE SECURED IN A WHEEL LIFT OR TOW DOLLIES, ENSURE THE TRANSMISSION IS IN THE PARK POSITION (AUTOMATIC TRANSMISSION) OR A FORWARD DRIVE GEAR (MANUAL TRANSMISSION).**

## TOWING-REAR END LIFTED (SLING TYPE)

- (1) Raise front of vehicle off ground and install tow dollies under front wheels.
- (2) Attach J-hooks around rear axle shaft tube outboard of shock absorber.
- (3) Place sling crossbar under and forward of bumper.
- (4) Attach safety chains around frame rails.
- (5) Turn ignition switch to OFF position to unlock steering wheel.
- (6) Secure steering wheel in the straight ahead position with a clamp device designed for towing.
- (7) Shift transfer case to neutral.

SERVICE PROCEDURES (Continued)

**TOWING-REAR END LIFTED (WHEEL LIFT)**

- (1) Raise front of vehicle off ground and install tow dollies under front wheels.
- (2) Attach wheel lift to rear wheels.
- (3) Place transmission in neutral.
- (4) Raise vehicle to towing height.
- (5) Place transmission in park (automatic transmission) or first gear (manual transmission).

**TOWING-FRONT END LIFTED**

To prevent damage to front fascia components, use only a Wheel-Lift type towing device or Flat-Bed hauling equipment.

- (1) Raise the rear of the vehicle off the ground and install tow dollies under rear wheels.
- (2) Attach wheel lift to front wheels.
- (3) Place transmission in neutral.
- (4) Raise vehicle to towing height.
- (5) Place transmission in park (automatic transmission) or first gear (manual transmission).

**EMERGENCY TOW HOOKS**

**WARNING: REMAIN AT A SAFE DISTANCE FROM A VEHICLE THAT IS BEING TOWED VIA ITS TOW HOOKS. THE TOW STRAPS/CHAINS COULD BREAK AND CAUSE SERIOUS INJURY.**

Some Jeep vehicles are equipped with front and rear emergency tow hooks. The tow hooks should be used for **EMERGENCY** purposes only.

**CAUTION: DO NOT use emergency tow hooks for tow truck hook-up or highway towing.**

**HOISTING RECOMMENDATIONS**

Refer to the Owner's Manual for emergency vehicle lifting procedures.

**FLOOR JACK**

When properly positioned, a floor jack can be used to lift a Jeep vehicle (Fig. 2) and (Fig. 3). Support the vehicle in the raised position with jack stands at the front and rear ends of the frame rails.

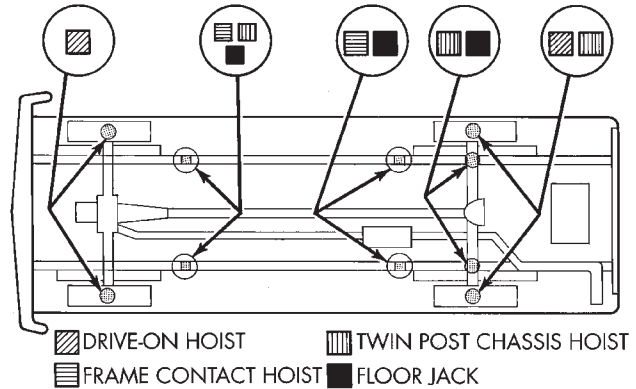
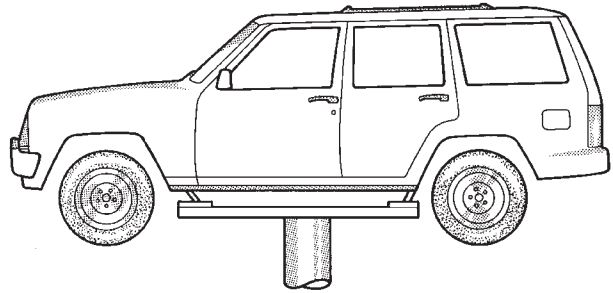

J9500-2

**Fig. 2 Vehicle Lifting Locations**

## SERVICE PROCEDURES (Continued)

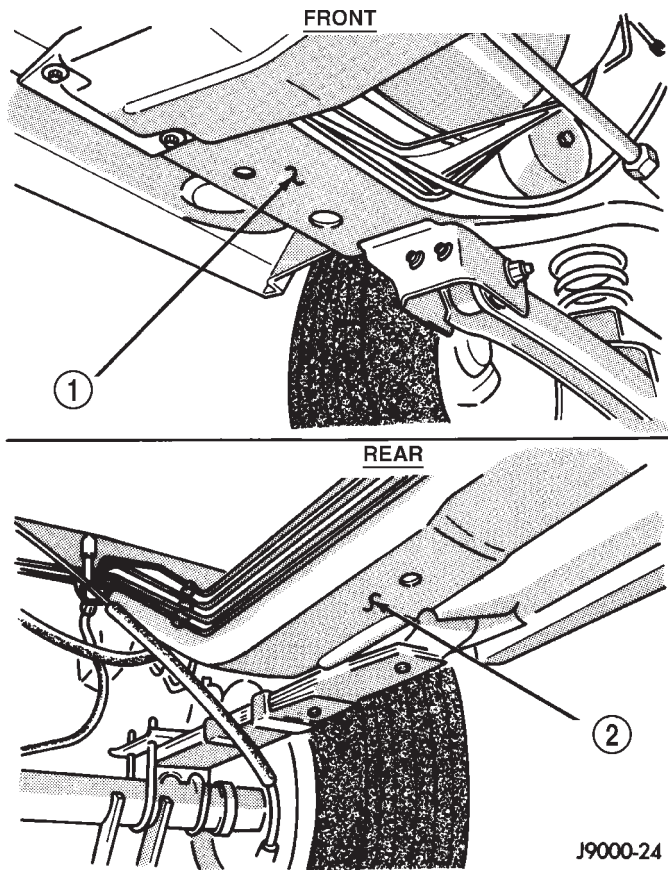

**Fig. 3 Correct Vehicle Lifting Locations**

- 1 - SUB-FRAME RAIL LOCATION  
2 - SUB-FRAME RAIL LOCATION

**CAUTION:** Do not attempt to lift a Jeep vehicle with a floor jack positioned under:

- An axle tube.
- A body side sill.
- A steering linkage component.
- A drive shaft.
- The engine or transmission oil pan.
- The fuel tank.
- A front suspension arm.

**NOTE:** Use the correct sub-frame rail or frame rail lifting locations only.

### HOIST

A vehicle can be lifted with:

- A single-post, frame-contact hoist.
- A twin-post, chassis hoist.
- A ramp-type, drive-on hoist.

**NOTE:** When a frame-contact type hoist is used, verify that the lifting pads are positioned properly.

**WARNING:** THE HOISTING AND JACK LIFTING POINTS PROVIDED ARE FOR A COMPLETE VEHICLE. WHEN A CHASSIS OR DRIVETRAIN COMPONENT IS REMOVED FROM A VEHICLE, THE CENTER OF GRAVITY IS ALTERED MAKING SOME HOISTING CONDITIONS UNSTABLE. PROPERLY SUPPORT OR SECURE VEHICLE TO HOISTING DEVICE WHEN THESE CONDITIONS EXIST.

J9000-24