

HEATING AND AIR CONDITIONING

TABLE OF CONTENTS

	page		page
DESCRIPTION AND OPERATION		REFRIGERANT SYSTEM LEAKS	17
ACCUMULATOR	2	VACUUM SYSTEM	18
BLOWER MOTOR	2	SERVICE PROCEDURES	
BLOWER MOTOR RELAY	2	REFRIGERANT OIL LEVEL	19
BLOWER MOTOR RESISTOR	3	REFRIGERANT RECOVERY	22
BLOWER MOTOR SWITCH	3	REFRIGERANT SYSTEM EVACUATE	22
COMPRESSOR	3	REFRIGERANT SYSTEM CHARGE	22
COMPRESSOR CLUTCH	3	REFRIGERANT SYSTEM SERVICE	
COMPRESSOR CLUTCH RELAY	4	EQUIPMENT	22
CONDENSER	4	REMOVAL AND INSTALLATION	
DUAL FUNCTION HIGH PRESSURE SWITCH		SERVICE WARNINGS AND PRECAUTIONS	23
(4.0 L)	4	ACCUMULATOR	25
EVAPORATOR COIL	4	BLEND-AIR DOOR MOTOR	26
FIXED ORIFICE TUBE	5	BLOWER MOTOR	26
HEATER AND AIR CONDITIONER	5	BLOWER MOTOR RELAY	27
HEATER AND AIR CONDITIONER CONTROL	6	BLOWER MOTOR RESISTOR	27
HEATER CORE	6	COMPRESSOR	28
HIGH PRESSURE CUT-OFF SWITCH	6	COMPRESSOR CLUTCH	29
HIGH PRESSURE RELIEF VALVE	7	COMPRESSOR CLUTCH RELAY	31
LOW PRESSURE CYCLING CLUTCH SWITCH	7	CONDENSER	32
REFRIGERANT	7	DUAL FUNCTION HIGH PRESSURE	
REFRIGERANT LINES	7	SWITCH/HIGH PRESSURE CUT-OFF	
REFRIGERANT LINE COUPLERS	8	SWITCH	33
REFRIGERANT OIL	8	DUCTS AND OUTLETS	33
REFRIGERANT SYSTEM SERVICE PORT	9	EVAPORATOR COIL	35
VACUUM CHECK VALVE	9	FIXED ORIFICE TUBE	35
VACUUM RESERVOIR	9	HEATER-A/C CONTROL	35
DIAGNOSIS AND TESTING		HEATER-A/C HOUSING	36
A/C PERFORMANCE	9	HEATER-A/C HOUSING DOOR	39
BLOWER MOTOR	12	HEATER CORE	41
BLOWER MOTOR RELAY	13	LIQUID LINE	41
BLOWER MOTOR RESISTOR	14	LOW PRESSURE CYCLING CLUTCH SWITCH	42
BLOWER MOTOR SWITCH	14	KICK COVER	42
COMPRESSOR	14	MODE DOOR VACUUM ACTUATOR	43
COMPRESSOR CLUTCH COIL	15	REFRIGERANT LINE COUPLER	45
COMPRESSOR CLUTCH RELAY	15	SUCTION AND DISCHARGE LINE	45
DUAL FUNCTION HIGH PRESSURE		VACUUM CHECK VALVE	46
SWITCH/HIGH PRESSURE CUT-OFF		VACUUM RESERVOIR	47
SWITCH	16	SPECIFICATIONS	
HEATER PERFORMANCE	16	A/C APPLICATION TABLE	47
LOW PRESSURE CYCLING CLUTCH SWITCH	17		

DESCRIPTION AND OPERATION

ACCUMULATOR

DESCRIPTION

The accumulator is mounted in the engine compartment between the evaporator coil outlet tube and the compressor inlet.

OPERATION

Refrigerant enters the accumulator canister as a low pressure vapor through the inlet tube. Any liquid, oil-laden refrigerant falls to the bottom of the canister, which acts as a separator. A desiccant bag is mounted inside the accumulator canister to absorb any moisture which may have entered and become trapped within the refrigerant system (Fig. 1).

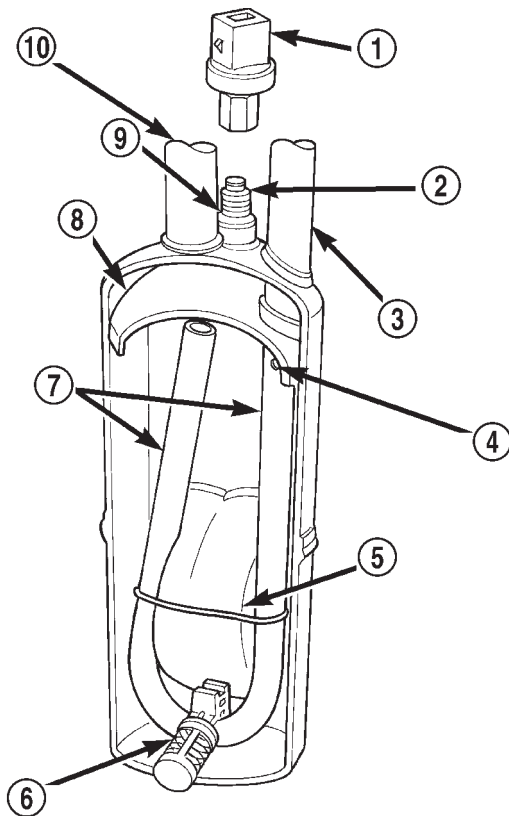

80add30t

Fig. 1 Accumulator - Typical

- 1 - LOW PRESSURE CYCLING CLUTCH SWITCH
- 2 - PRESSURE SWITCH FITTING
- 3 - OUTLET TO COMPRESSOR
- 4 - ANTI-SIPHON HOLE
- 5 - DESICCANT BAG
- 6 - OIL RETURN ORIFICE FILTER
- 7 - VAPOR RETURN TUBE
- 8 - ACCUMULATOR DOME
- 9 - O-RING SEAL
- 10 - INLET FROM EVAPORATOR

BLOWER MOTOR

DESCRIPTION

The blower motor and blower wheel are located in the passenger side end of the heater-A/C housing, below the glove box. The blower motor controls the velocity of air flowing through the heater-A/C housing by spinning a squirrel cage-type blower wheel within the housing at the selected speed. The blower motor and wheel can be removed through an opening in the engine compartment side of the dash panel without heater-A/C housing removal.

OPERATION

The blower motor will only operate when the ignition switch is in the On position, and the heater-A/C mode control switch knob is in any position, except Off. The blower motor receives a fused battery feed through the blower motor relay whenever the ignition switch is in the On position. The blower motor battery feed circuit is protected by a fuse in the Power Distribution Center (PDC). Blower motor speed is controlled by regulating the ground path through the heater-A/C control blower motor switch and the blower motor resistor.

The blower motor and blower motor wheel cannot be repaired and, if faulty or damaged, they must be replaced. The blower motor and blower wheel are serviced only as a unit.

BLOWER MOTOR RELAY

DESCRIPTION

The blower motor relay is a International Standards Organization (ISO)-type relay. The relay is an electromechanical device that switches battery current from a fuse in the Power Distribution Center (PDC) directly to the blower motor. The relay is energized when the relay coil is provided a voltage signal by the ignition switch. See Blower Motor Relay in the Diagnosis and Testing section of this group for more information.

OPERATION

The blower motor relay is installed in a wire harness connector that is secured to the passenger side outboard end of the heater-A/C housing in the passenger compartment, next to the heater-A/C wire harness connector.

The blower motor relay cannot be repaired and, if faulty or damaged, it must be replaced.

DESCRIPTION AND OPERATION (Continued)

BLOWER MOTOR RESISTOR**DESCRIPTION**

The blower motor resistor is mounted to the bottom of the heater-A/C housing on the passenger side of the vehicle under the instrument panel. It can be accessed for service by removing the heater-A/C housing kick cover.

OPERATION

The resistor has multiple resistor wires, each of which reduce the current flow to the blower motor, to change the blower motor speed. The blower motor switch directs the ground path through the correct resistor wire to obtain the selected speed. When the highest blower speed is selected, the blower motor switch connects the blower motor directly to ground, bypassing the blower motor resistor.

The blower motor resistor cannot be repaired and, if faulty or damaged, it must be replaced.

BLOWER MOTOR SWITCH**DESCRIPTION**

The heater-only or heater-A/C blower motor is controlled by a four position rotary-type blower motor switch, mounted in the heater-A/C control panel. The switch allows the selection of one of four blower motor speeds, but can only be turned off by selecting the Off position with the heater-A/C mode control switch knob.

OPERATION

The blower motor switch directs the blower motor ground path through the mode control switch to the blower motor resistor, or directly to ground, as required to achieve the selected blower motor speed.

The blower motor switch cannot be repaired and, if faulty or damaged, the entire heater-only or heater-A/C control unit must be replaced.

COMPRESSOR**DESCRIPTION**

The air conditioning system uses a Sanden SD7H15 seven cylinder, reciprocating wobble plate-type compressor on all models. This compressor has a fixed displacement of 150 cubic centimeters (9.375 cubic inches), and has both the suction and discharge ports located on the cylinder head. A label identifying the use of R-134a refrigerant is located on the compressor.

OPERATION

The compressor is driven by the engine through an electric clutch, drive pulley and belt arrangement.

The compressor is lubricated by refrigerant oil that is circulated throughout the refrigerant system with the refrigerant.

The compressor draws in low-pressure refrigerant vapor from the evaporator through its suction port. It then compresses the refrigerant into a high-pressure, high-temperature refrigerant vapor, which is then pumped to the condenser through the compressor discharge port.

The compressor cannot be repaired. If faulty or damaged, the entire compressor assembly must be replaced. The compressor clutch, pulley and clutch coil are available for service.

COMPRESSOR CLUTCH**DESCRIPTION**

The compressor clutch assembly consists of a stationary electromagnetic coil, a hub bearing and pulley assembly, and a clutch plate (Fig. 2). The electromagnetic coil unit and the hub bearing and pulley assembly are each retained on the nose of the compressor front housing with snap rings. The clutch plate is keyed to the compressor shaft and secured with a nut. These components provide the means to engage and disengage the compressor from the engine serpentine accessory drive belt.

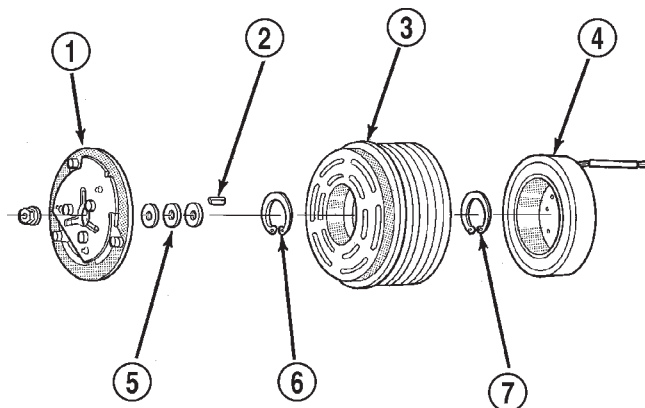

J9524-33

Fig. 2 Compressor Clutch - Typical

- 1 - CLUTCH PLATE
- 2 - SHAFT KEY
- 3 - PULLEY
- 4 - COIL
- 5 - CLUTCH SHIMS
- 6 - SNAP RING
- 7 - SNAP RING

OPERATION

When the clutch coil is energized, it magnetically draws the clutch into contact with the pulley and drives the compressor shaft. When the coil is not energized, the pulley freewheels on the clutch hub.

DESCRIPTION AND OPERATION (Continued)

bearing, which is part of the pulley. The compressor clutch and coil are the only serviced parts on the compressor.

The compressor clutch engagement is controlled by several components: the heater-A/C mode control switch, the low pressure cycling clutch switch, the high pressure cut-off switch, the compressor clutch relay, and the Powertrain Control Module (PCM). The PCM may delay compressor clutch engagement for up to thirty seconds. Refer to Group 14 - Fuel System for more information on the PCM controls.

COMPRESSOR CLUTCH RELAY

DESCRIPTION

The compressor clutch relay is a International Standards Organization (ISO) micro-relay. The terminal designations and functions are the same as a conventional ISO relay. However, the micro-relay terminal orientation (footprint) is different, the current capacity is lower, and the relay case dimensions are smaller than those of the conventional ISO relay.

The compressor clutch relay is located in the Power Distribution Center (PDC) in the engine compartment. Refer to the PDC label for relay identification and location.

OPERATION

The compressor clutch relay is a electromechanical device that switches battery current to the compressor clutch coil when the Powertrain Control Module (PCM) grounds the coil side of the relay. The PCM responds to inputs from the heater-A/C mode control switch, the low pressure cycling clutch switch, and the high pressure cut-off switch. See Compressor Clutch Relay in the Diagnosis and Testing section of this group for more information.

The compressor clutch relay cannot be repaired and, if faulty or damaged, it must be replaced.

CONDENSER

DESCRIPTION

The condenser is located in the air flow in front of the engine cooling radiator. The condenser is a heat exchanger that allows the high-pressure refrigerant gas being discharged by the compressor to give up its heat to the air passing over the condenser fins.

OPERATION

When the refrigerant gas gives up its heat, it condenses. When the refrigerant leaves the condenser, it has become a high-pressure liquid refrigerant. The volume of air flowing over the condenser fins is critical to the proper cooling performance of the air conditioning system. Therefore, it is important that

there are no objects placed in front of the radiator grille openings in the front of the vehicle or foreign material on the condenser fins that might obstruct proper air flow. Also, any factory-installed air seals or shrouds must be properly reinstalled following radiator or condenser service.

The condenser cannot be repaired and, if faulty or damaged, it must be replaced.

DUAL FUNCTION HIGH PRESSURE SWITCH (4.0 L)

DESCRIPTION

The Dual Function High Pressure Switch controls both A/C clutch engagement/disengagement, and electric cooling fan operations. The switch is located on the discharge line near the compressor. The switch is screwed onto a fitting that contains a Schrader-type valve, which allows the switch to be serviced without discharging the refrigerant system. The discharge line fitting is equipped with an O-ring to seal the switch connection.

OPERATION

The dual function switch is connected in series electrically with the low pressure cycling clutch switch between ground and the Powertrain Control Module (PCM). The switch contacts open and close causing the PCM to turn the compressor clutch on and off. This prevents compressor operation when the discharge line pressure approaches high levels, and also reduces electrical surging from compressor clutch engagement.

The dual function switch controls the electric cooling fan operation by monitoring refrigerant line pressures. When the discharge line pressure rises above 1900 to 2200 kPa (280 to 320 psi) the fan will turn on. The cooling fan will turn off when the discharge line pressure drops to 1600 kPa (235 psi).

The dual function switch controls the A/C clutch operation by disengaging the clutch when the discharge line pressure rises above 3100 to 3375 kPa (450 to 490 psi). The switch contacts will close and allow A/C clutch engagement when the discharge line pressure drops to 1860 to 2275 kPa (270 to 330 psi).

The Dual Function High Pressure Switch is a factory-calibrated unit. The switch cannot be adjusted or repaired and, if faulty or damaged, it must be replaced.

EVAPORATOR COIL

DESCRIPTION

The evaporator coil is located in the heater-A/C housing, under the instrument panel. The evaporator coil is positioned in the heater-A/C housing so that

DESCRIPTION AND OPERATION (Continued)

all air that enters the housing must pass over the fins of the evaporator before it is distributed through the system ducts and outlets. However, air passing over the evaporator coil fins will only be conditioned when the compressor is engaged and circulating refrigerant through the evaporator coil tubes.

OPERATION

Refrigerant enters the evaporator from the fixed orifice tube as a low-temperature, low-pressure liquid. As air flows over the fins of the evaporator, the humidity in the air condenses on the fins, and the heat from the air is absorbed by the refrigerant. Heat absorption causes the refrigerant to boil and vaporize. The refrigerant becomes a low-pressure gas when it leaves the evaporator.

The evaporator coil cannot be repaired and, if faulty or damaged, it must be replaced.

FIXED ORIFICE TUBE

DESCRIPTION

The fixed orifice tube is installed in the liquid line (left-hand drive) or liquid line jumper (right-hand drive) between the outlet of the condenser and the inlet of the evaporator. The fixed orifice tube is located in the end of the liquid line or liquid line jumper that is closest to the condenser outlet tube.

The inlet end of the fixed orifice tube has a nylon mesh filter screen, which filters the refrigerant and helps to reduce the potential for blockage of the metering orifice by refrigerant system contaminants (Fig. 3). The outlet end of the tube has a nylon mesh diffuser screen. The O-rings on the plastic body of the fixed orifice tube seal the tube to the inside of the liquid line and prevent the refrigerant from bypassing the fixed metering orifice.

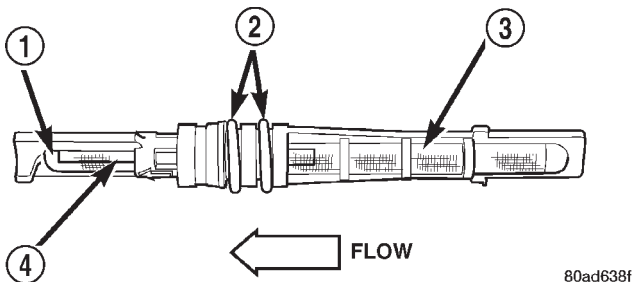

Fig. 3 Fixed Orifice Tube - Typical

- 1 - DIFFUSER SCREEN
- 2 - "O" RINGS
- 3 - INLET FILTER SCREEN
- 4 - ORIFICE

OPERATION

The fixed orifice tube is used to meter the flow of liquid refrigerant into the evaporator coil. The high-

pressure liquid refrigerant from the condenser expands into a low-pressure liquid as it passes through the metering orifice and diffuser screen of the fixed orifice tube.

The fixed orifice tube cannot be repaired and, if faulty or plugged, the liquid line and fixed orifice tube unit or liquid line jumper and fixed orifice tube unit must be replaced.

HEATER AND AIR CONDITIONER

DESCRIPTION

All vehicles are equipped with a common heater-A/C housing assembly (Fig. 4). The system combines air conditioning, heating, and ventilating capabilities in a single unit housing mounted under the instrument panel. On heater-only systems, the evaporator coil and recirculating air door are omitted from the housing.

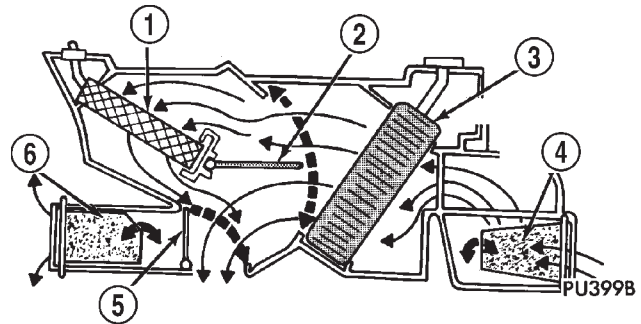

Fig. 4 Common Blend-Air Heater-Air Conditioner System - Typical

- 1 - HEATER CORE
- 2 - BLEND-AIR DOOR
- 3 - EVAPORATOR A/C ONLY
- 4 - RECIRCULATING AIR DOOR A/C ONLY
- 5 - FLOOR/PANEL DOOR
- 6 - FLOOR/DEFROST DOOR

Outside fresh air enters the vehicle through the cowl top opening at the base of the windshield, and passes through a plenum chamber to the heater-A/C system blower housing. Air flow velocity can then be adjusted with the blower motor speed selector switch on the heater-A/C control panel. The air intake openings must be kept free of snow, ice, leaves, and other obstructions for the heater-A/C system to receive a sufficient volume of outside air.

It is also important to keep the air intake openings clear of debris because leaf particles and other debris that is small enough to pass through the cowl plenum screen can accumulate within the heater-A/C housing. The closed, warm, damp and dark environment created within the heater-A/C housing is ideal for the growth of certain molds, mildews and other fungi. Any accumulation of decaying plant matter

DESCRIPTION AND OPERATION (Continued)

provides an additional food source for fungal spores, which enter the housing with the fresh air. Excess debris, as well as objectionable odors created by decaying plant matter and growing fungi can be discharged into the passenger compartment during heater-A/C system operation.

OPERATION

The heater and optional air conditioner are blend-air type systems. In a blend-air system, a blend-air door controls the amount of unconditioned air (or cooled air from the evaporator on models with air conditioning) that is allowed to flow through, or around, the heater core. A temperature control knob on the heater-A/C control panel determines the discharge air temperature by controlling an electric motor, which moves the blend-air door. This allows an almost immediate control of the output air temperature of the system.

The mode control knob on the heater-only or heater-A/C control panel is used to direct the conditioned air to the selected system outlets. Both mode control switches use engine vacuum to control the mode doors, which are operated by vacuum actuator motors.

On air conditioned vehicles, the outside air intake can be shut off by selecting the Recirculation Mode with the mode control knob. This will operate a vacuum actuated recirculating air door that closes off the outside fresh air intake and recirculates the air that is already inside the vehicle.

The optional air conditioner for all models is designed for the use of non-CFC, R-134a refrigerant. The air conditioning system has an evaporator to cool and dehumidify the incoming air prior to blending it with the heated air. This air conditioning system uses a fixed orifice tube in the liquid line near the condenser outlet tube to meter refrigerant flow to the evaporator coil. To maintain minimum evaporator temperature and prevent evaporator freezing, a fixed pressure setting switch on the accumulator cycles the compressor clutch.

HEATER AND AIR CONDITIONER CONTROL**DESCRIPTION**

Both the heater-only and heater-A/C systems use a combination of mechanical, electrical, and vacuum controls. These controls provide the vehicle operator with a number of setting options to help control the climate and comfort within the vehicle. Refer to the owner's manual in the vehicle glove box for more information on the features, use, and suggested operation of these controls.

OPERATION

The heater-only or heater-A/C control panel is located to the right of the instrument cluster on the instrument panel. The control panel contains a rotary-type temperature control knob, a rotary-type mode control switch knob, and a rotary-type blower motor speed switch knob.

The heater-only or heater-A/C control panel cannot be repaired. If faulty or damaged, the entire unit must be replaced. The illumination lamps are available for service replacement.

HEATER CORE**DESCRIPTION**

The heater core is located in the heater-A/C housing, under the instrument panel. It is a heat exchanger made of rows of tubes and fins.

OPERATION

Engine coolant is circulated through heater hoses to the heater core at all times. As the coolant flows through the heater core, heat removed from the engine is transferred to the heater core fins and tubes. Air directed through the heater core picks up the heat from the heater core fins. The blend air door allows control of the heater output air temperature by controlling how much of the air flowing through the heater-A/C housing is directed through the heater core. The blower motor speed controls the volume of air flowing through the heater-A/C housing.

The heater core cannot be repaired and, if faulty or damaged, it must be replaced. Refer to Group 7 - Cooling System for more information on the engine cooling system, the engine coolant and the heater hoses.

HIGH PRESSURE CUT-OFF SWITCH**DESCRIPTION**

The high pressure cut-off switch is located on the discharge line between the compressor and the condenser inlet. The switch is screwed onto a fitting that contains a Schrader-type valve, which allows the switch to be serviced without discharging the refrigerant system. The discharge line fitting is equipped with an O-ring to seal the switch connection.

OPERATION

The high pressure cut-off switch is connected in series electrically with the low pressure cycling clutch switch between ground and the Powertrain Control Module (PCM). The switch contacts open and close causing the PCM to turn the compressor clutch on and off. This prevents compressor operation when the discharge line pressure approaches high levels.

DESCRIPTION AND OPERATION (Continued)

The high pressure cut-off switch contacts are open when the discharge line pressure rises above 3100 to 3375 kPa (450 to 490 psi). The switch contacts will close when the discharge line pressure drops to 1860 to 2275 kPa (270 to 330 psi).

The high pressure cut-off switch is a factory-calibrated unit. The switch cannot be adjusted or repaired and, if faulty or damaged, it must be replaced.

HIGH PRESSURE RELIEF VALVE

DESCRIPTION

A high pressure relief valve is located on the compressor manifold, which is on the side of the compressor. This mechanical valve is designed to vent refrigerant from the system to protect against damage to the compressor and other system components, caused by condenser air flow restriction or an over-charge of refrigerant.

OPERATION

The high pressure relief valve vents the system when a discharge pressure of 3445 to 4135 kPa (500 to 600 psi) or above is reached. The valve closes when a minimum discharge pressure of 2756 kPa (400 psi) is reached.

The high pressure relief valve vents only enough refrigerant to reduce the system pressure, and then re-seats itself. The majority of the refrigerant is conserved in the system. If the valve vents refrigerant, it does not mean that the valve is faulty.

The high pressure relief valve is a factory-calibrated unit. The valve cannot be adjusted or repaired, and must not be removed or otherwise disturbed. The valve is only serviced as a part of the compressor assembly.

LOW PRESSURE CYCLING CLUTCH SWITCH

DESCRIPTION

The low pressure cycling clutch switch is located on the top of the accumulator. The switch is screwed onto an accumulator fitting that contains a Schrader-type valve, which allows the switch to be serviced without discharging the refrigerant system. The accumulator fitting is equipped with an O-ring to seal the switch connection.

OPERATION

The low pressure cycling clutch switch is connected in series electrically with the high pressure cut-off switch, between ground and the Powertrain Control Module (PCM). The switch contacts open and close causing the PCM to turn the compressor clutch on and off. This regulates the refrigerant system pres-

sure and controls evaporator temperature. Controlling the evaporator temperature prevents condensate water on the evaporator fins from freezing and obstructing air conditioning system air flow.

The low pressure cycling clutch switch contacts are open when the suction pressure is approximately 141 kPa (20.5 psi) or lower. The switch contacts will close when the suction pressure rises to approximately 234 to 262 kPa (34 to 38 psi) or above. Lower ambient temperatures, below approximately -1° C (30° F), will also cause the switch contacts to open. This is due to the pressure/temperature relationship of the refrigerant in the system.

The low pressure cycling clutch switch is a factory-calibrated unit. It cannot be adjusted or repaired and, if faulty or damaged, it must be replaced.

REFRIGERANT

DESCRIPTION

The refrigerant used in this air conditioning system is a HydroFluoroCarbon (HFC), type R-134a. Unlike R-12, which is a ChloroFluoroCarbon (CFC), R-134a refrigerant does not contain ozone-depleting chlorine. R-134a refrigerant is a non-toxic, non-flammable, clear, and colorless liquefied gas.

Even though R-134a does not contain chlorine, it must be reclaimed and recycled just like CFC-type refrigerants. This is because R-134a is a greenhouse gas and can contribute to global warming.

OPERATION

R-134a refrigerant is not compatible with R-12 refrigerant in an air conditioning system. Even a small amount of R-12 added to an R-134a refrigerant system will cause compressor failure, refrigerant oil sludge or poor air conditioning system performance. In addition, the PolyAlkylene Glycol (PAG) synthetic refrigerant oils used in an R-134a refrigerant system are not compatible with the mineral-based refrigerant oils used in an R-12 refrigerant system.

R-134a refrigerant system service ports, service tool couplers and refrigerant dispensing bottles have all been designed with unique fittings to ensure that an R-134a system is not accidentally contaminated with the wrong refrigerant (R-12). There are also labels posted in the engine compartment of the vehicle and on the compressor identifying to service technicians that the air conditioning system is equipped with R-134a.

REFRIGERANT LINES

DESCRIPTION

The refrigerant lines and hoses are used to carry the refrigerant between the various air conditioning

DESCRIPTION AND OPERATION (Continued)

system components. A barrier hose design with a nylon tube, which is sandwiched between rubber layers, is used for the R-134a air conditioning system on this vehicle. This nylon tube helps to further contain the R-134a refrigerant, which has a smaller molecular structure than R-12 refrigerant. The ends of the refrigerant hoses are made from lightweight aluminum or steel, and commonly use braze-less fittings.

Any kinks or sharp bends in the refrigerant plumbing will reduce the capacity of the entire air conditioning system. Kinks and sharp bends reduce the flow of refrigerant in the system. A good rule for the flexible hose refrigerant lines is to keep the radius of all bends at least ten times the diameter of the hose. In addition, the flexible hose refrigerant lines should be routed so they are at least 80 millimeters (3 inches) from the exhaust manifold.

OPERATION

High pressures are produced in the refrigerant system when the air conditioning compressor is operating. Extreme care must be exercised to make sure that each of the refrigerant system connections is pressure-tight and leak free. It is a good practice to inspect all flexible hose refrigerant lines at least once a year to make sure they are in good condition and properly routed.

The refrigerant lines and hoses are coupled with other components of the HVAC system with peanut-block style fittings. A stat-O seal type flat steel gasket with a captured compressible O-ring, is used to mate plumbing lines with A/C components to ensure the integrity of the refrigerant system.

The refrigerant lines and hoses cannot be repaired and, if faulty or damaged, they must be replaced.

REFRIGERANT LINE COUPLERS

DESCRIPTION

Spring-lock type refrigerant line couplers are used to connect many of the refrigerant lines and other components to the refrigerant system. These couplers require a special tool for disengaging the two coupler halves.

OPERATION

The spring-lock coupler is held together by a garter spring inside a circular cage on the male half of the fitting (Fig. 5). When the two coupler halves are connected, the flared end of the female fitting slips behind the garter spring inside the cage on the male fitting. The garter spring and cage prevent the flared end of the female fitting from pulling out of the cage.

Two O-rings on the male half of the fitting are used to seal the connection. These O-rings are com-

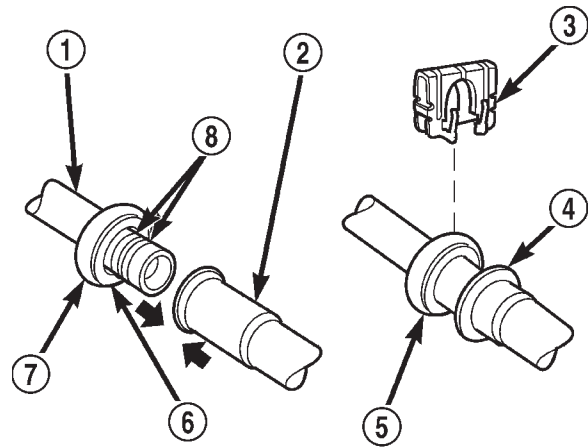

80a7e303

Fig. 5 Spring-Lock Coupler - Typical

- 1 - MALE HALF SPRING-LOCK COUPLER
- 2 - FEMALE HALF SPRING-LOCK COUPLER
- 3 - SECONDARY CLIP
- 4 - CONNECTION INDICATOR RING
- 5 - COUPLER CAGE
- 6 - GARTER SPRING
- 7 - COUPLER CAGE
- 8 - "O" RINGS

patible with R-134a refrigerant and must be replaced with O-rings made of the same material.

Secondary clips are installed over the two connected coupler halves at the factory for added blowoff protection. In addition, some models have a plastic ring that is used at the factory as a visual indicator to confirm that these couplers are connected. After the coupler is connected, the plastic indicator ring is no longer needed; however, it will remain on the refrigerant line near the coupler cage.

REFRIGERANT OIL

DESCRIPTION

The refrigerant oil used in R-134a refrigerant systems is a synthetic-based, PolyAlkylene Glycol (PAG), wax-free lubricant. Mineral-based R-12 refrigerant oils are not compatible with PAG oils, and should never be introduced to an R-134a refrigerant system.

There are different PAG oils available, and each contains a different additive package. The 10PA17 compressor used in this vehicle is designed to use an ND-8 PAG refrigerant oil. Use only refrigerant oil of this same type to service the refrigerant system.

OPERATION

After performing any refrigerant recovery or recycling operation, always replenish the refrigerant system with the same amount of the recommended refrigerant oil as was removed. Too little refrigerant

DESCRIPTION AND OPERATION (Continued)

oil can cause compressor damage, and too much can reduce air conditioning system performance.

PAG refrigerant oil is much more hygroscopic than mineral oil, and will absorb any moisture it comes into contact with, even moisture in the air. The PAG oil container should always be kept tightly capped until it is ready to be used. After use, recap the oil container immediately to prevent moisture contamination.

REFRIGERANT SYSTEM SERVICE PORT**DESCRIPTION**

The two refrigerant system service ports are used to charge, recover/recycle, evacuate, and test the air conditioning refrigerant system. Unique service port coupler sizes are used on the R-134a system, to ensure that the refrigerant system is not accidentally contaminated by the use of the wrong refrigerant (R-12), or refrigerant system service equipment.

OPERATION

The high pressure service port is located on the refrigerant line, near the discharge port of the compressor. The low pressure service port is located on the liquid line at the rear of the engine compartment, near the evaporator inlet tube.

Each of the service ports has a threaded plastic protective cap installed over it from the factory. After servicing the refrigerant system, always reinstall both of the service port caps.

VACUUM CHECK VALVE**DESCRIPTION**

A vacuum check valve is installed in the accessory vacuum supply line in the engine compartment, near the vacuum tap on the engine intake manifold, and at the HVAC unit takeout. The vacuum check valve is designed to allow vacuum to flow in only one direction through the accessory vacuum supply circuits.

OPERATION

The use of a vacuum check valve helps to maintain the system vacuum needed to retain the selected heater-A/C mode settings. The check valve will prevent the engine from bleeding down system vacuum through the intake manifold during extended heavy engine load (low engine vacuum) operation.

The vacuum check valve cannot be repaired and, if faulty or damaged, it must be replaced.

VACUUM RESERVOIR**DESCRIPTION**

The vacuum reservoir is mounted to the front bumper bar behind the passenger side bumper end cap. The bumper end cap must be removed from the vehicle to access the vacuum reservoir for service.

OPERATION

Engine vacuum is stored in the vacuum reservoir. The stored vacuum is used to operate the vacuum-controlled vehicle accessories during periods of low engine vacuum such as when the vehicle is climbing a steep grade, or under other high engine load operating conditions.

The vacuum reservoir cannot be repaired and, if faulty or damaged, it must be replaced.

DIAGNOSIS AND TESTING**A/C PERFORMANCE**

The air conditioning system is designed to provide the passenger compartment with low temperature and low humidity air. The evaporator, located in the heater-A/C housing on the dash panel below the instrument panel, is cooled to temperatures near the freezing point. As warm damp air passes through the cooled evaporator, the air transfers its heat to the refrigerant in the evaporator and the moisture in the air condenses on the evaporator fins. During periods of high heat and humidity, an air conditioning system will be more effective in the Recirculation Mode. With the system in the Recirculation Mode, only air from the passenger compartment passes through the evaporator. As the passenger compartment air dehumidifies, the air conditioning system performance levels improve.

Humidity has an important bearing on the temperature of the air delivered to the interior of the vehicle. It is important to understand the effect that humidity has on the performance of the air conditioning system. When humidity is high, the evaporator has to perform a double duty. It must lower the air temperature, and it must lower the temperature of the moisture in the air that condenses on the evaporator fins. Condensing the moisture in the air transfers heat energy into the evaporator fins and tubing. This reduces the amount of heat the evaporator can absorb from the air. High humidity greatly reduces the ability of the evaporator to lower the temperature of the air.

DIAGNOSIS AND TESTING (Continued)

However, evaporator capacity used to reduce the amount of moisture in the air is not wasted. Wringing some of the moisture out of the air entering the vehicle adds to the comfort of the passengers. Although, an owner may expect too much from their air conditioning system on humid days. A performance test is the best way to determine whether the system is performing up to standard. This test also provides valuable clues as to the possible cause of trouble with the air conditioning system.

Review the Service Warnings and Precautions in the front of this group before performing this procedure. The air temperature in the test room and in the vehicle must be a minimum of 21° C (70° F) for this test.

(1) Connect a tachometer and a manifold gauge set.

(2) Set the heater-A/C mode control switch knob in the Recirculation Mode position, the temperature control knob in the full cool position, and the blower motor switch knob in the highest speed position.

(3) Start the engine and hold the idle at 1,000 rpm with the compressor clutch engaged.

(4) The engine should be at operating temperature. The doors and windows must be open.

(5) Insert a thermometer in the driver side center A/C (panel) outlet. Operate the engine for five minutes.

(6) The compressor clutch may cycle, depending upon the ambient temperature and humidity. If the clutch cycles, unplug the low pressure cycling clutch switch wire harness connector from the switch

located on the accumulator (Fig. 6). Place a jumper wire across the terminals of the low pressure cycling clutch switch wire harness connector.

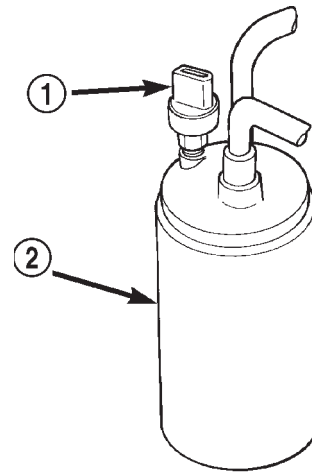

80add30d

Fig. 6 Low Pressure Cycling Clutch Switch - Typical

- 1 - LOW PRESSURE CYCLING CLUTCH SWITCH
- 2 - ACCUMULATOR

(7) With the compressor clutch engaged, record the discharge air temperature and the compressor discharge pressure.

(8) Compare the discharge air temperature to the Performance Temperature and Pressure chart. If the discharge air temperature is high, see Refrigerant System Leaks and Refrigerant System Charge in this group.

Performance Temperature and Pressure					
Ambient Air Temperature	21° C (70° F)	27° C (80° F)	32° C (90° F)	38° C (100° F)	43° C (110° F)
Air Temperature at Center Panel Outlet	-3 to 3° C (27 to 38° F)	1 to 7° C (33 to 44° F)	3 to 9° C (37 to 48° F)	6 to 13° C (43 to 55° F)	10 to 18° C (50 to 64° F)
Evaporator Inlet Pressure at Charge Port	179 to 241 kPa (26 to 35 psi)	221 to 283 kPa (32 to 41 psi)	262 to 324 kPa (38 to 47 psi)	303 to 365 kPa (44 to 53 psi)	345 to 414 kPa (50 to 60 psi)
Compressor Discharge Pressure	1240 to 1655 kPa (180 to 240 psi)	1380 to 1790 kPa (200 to 260 psi)	1720 to 2070 kPa (250 to 300 psi)	1860 to 2345 kPa (270 to 340 psi)	2070 to 2690 kPa (300 to 390 psi)

(9) Compare the compressor discharge pressure to the Performance Temperature and Pressure chart. If the compressor discharge pressure is high, see the Pressure Diagnosis chart.

DIAGNOSIS AND TESTING (Continued)

Pressure Diagnosis		
Condition	Possible Causes	Correction
Rapid compressor clutch cycling (ten or more cycles per minute).	1. Low refrigerant system charge.	1. See Refrigerant System Leaks in this group. Test the refrigerant system for leaks. Repair, evacuate and charge the refrigerant system, if required.
Equal pressures, but the compressor clutch does not engage.	1. No refrigerant in the refrigerant system. 2. Faulty fuse. 3. Faulty compressor clutch coil. 4. Faulty compressor clutch relay. 5. Improperly installed or faulty low pressure cycling clutch switch. 6. Faulty high pressure cut-off switch. 7. Faulty Powertrain Control Module (PCM).	1. See Refrigerant System Leaks in this group. Test the refrigerant system for leaks. Repair, evacuate and charge the refrigerant system, if required. 2. Check the fuses in the Power Distribution Center and the junction block. Repair the shorted circuit or component and replace the fuses, if required. 3. See Compressor Clutch Coil in this group. Test the compressor clutch coil and replace, if required. 4. See Compressor Clutch Relay in this group. Test the compressor clutch relay and relay circuits. Repair the circuits or replace the relay, if required. 5. See Low Pressure Cycling Clutch Switch in this group. Test the low pressure cycling clutch switch and tighten or replace, if required. 6. See High Pressure Cut-Off Switch in this group. Test the high pressure cut-off switch and replace, if required. 7. Refer to the proper Diagnostic Procedures manual for testing of the PCM. Test the PCM and replace, if required.
Normal pressures, but A/C Performance Test air temperatures at center panel outlet are too high.	1. Excessive refrigerant oil in system. 2. Blend-Air door inoperative or sealing improperly. 3. Blend-Air door motor faulty or inoperative.	1. See Refrigerant Oil Level in this group. Recover the refrigerant from the refrigerant system and inspect the refrigerant oil content. Restore the refrigerant oil to the proper level, if required. 2. See Blend-Air Door under Heater-A/C Housing Door in this group. Inspect the blend-air door for proper operation and sealing and correct, if required. 3. Perform Blend-Air door motor diagnosis, replace if faulty.
The low side pressure is normal or slightly low, and the high side pressure is too low.	1. Low refrigerant system charge. 2. Refrigerant flow through the accumulator is restricted. 3. Refrigerant flow through the evaporator coil is restricted. 4. Faulty compressor.	1. See Refrigerant System Leaks in this group. Test the refrigerant system for leaks. Repair, evacuate and charge the refrigerant system, if required. 2. See Accumulator in this group. Replace the restricted accumulator, if required. 3. See Evaporator Coil in this group. Replace the restricted evaporator coil, if required. 4. See Compressor in this group. Replace the compressor, if required.

DIAGNOSIS AND TESTING (Continued)

Pressure Diagnosis		
Condition	Possible Causes	Correction
The low side pressure is normal or slightly high, and the high side pressure is too high.	<ol style="list-style-type: none"> 1. Condenser air flow restricted. 2. Inoperative cooling fan. 3. Refrigerant system overcharged. 4. Air in the refrigerant system. 5. Engine overheating. 	<ol style="list-style-type: none"> 1. Check the condenser for damaged fins, foreign objects obstructing air flow through the condenser fins, and missing or improperly installed air seals. Refer to Group 7 - Cooling System for more information on air seals. Clean, repair, or replace components as required. 2. Refer to Group 7 - Cooling System for more information. Test the cooling fan and replace, if required. 3. See Refrigerant System Charge in this group. Recover the refrigerant from the refrigerant system. Charge the refrigerant system to the proper level, if required. 4. See Refrigerant System Leaks in this group. Test the refrigerant system for leaks. Repair, evacuate and charge the refrigerant system, if required. 5. Refer to Group 7 - Cooling System for more information. Test the cooling system and repair, if required.
The low side pressure is too high, and the high side pressure is too low.	<ol style="list-style-type: none"> 1. Accessory drive belt slipping. 2. Fixed orifice tube not installed. 3. Faulty compressor. 	<ol style="list-style-type: none"> 1. Refer to Group 7 - Cooling System for more information. Inspect the accessory drive belt condition and tension. Tighten or replace the accessory drive belt, if required. 2. See Fixed Orifice Tube in this group. Install the missing fixed orifice tube, if required. 3. See Compressor in this group. Replace the compressor, if required.
The low side pressure is too low, and the high side pressure is too high.	<ol style="list-style-type: none"> 1. Restricted refrigerant flow through the refrigerant lines. 2. Restricted refrigerant flow through the fixed orifice tube. 3. Restricted refrigerant flow through the condenser. 	<ol style="list-style-type: none"> 1. See Liquid Line and Suction and Discharge Line in this group. Inspect the refrigerant lines for kinks, tight bends or improper routing. Correct the routing or replace the refrigerant line, if required. 2. See Fixed Orifice Tube in this group. Replace the restricted fixed orifice tube, if required. 3. See Condenser in this group. Replace the restricted condenser, if required.

BLOWER MOTOR

WARNING: ON VEHICLES EQUIPPED WITH AIRBAGS, REFER TO GROUP 8M - PASSIVE RESTRAINT SYSTEMS BEFORE ATTEMPTING ANY STEERING WHEEL, STEERING COLUMN, OR INSTRUMENT PANEL COMPONENT DIAGNOSIS OR SERVICE. FAILURE TO TAKE THE PROPER PRECAUTIONS COULD RESULT IN ACCIDENTAL AIRBAG DEPLOYMENT AND POSSIBLE PERSONAL INJURY.

For circuit descriptions and diagrams, refer to 8W-42 - Air Conditioning/Heater in Group 8W - Wiring Diagrams. Possible causes of an inoperative blower motor include:

- Faulty fuse
 - Faulty blower motor circuit wiring or wire harness connectors
 - Faulty blower motor resistor
 - Faulty blower motor relay
 - Faulty blower motor switch
 - Faulty heater-A/C mode control switch
 - Faulty blower motor.
- Possible causes of the blower motor not operating in all speeds include:
- Faulty fuse
 - Faulty blower motor switch
 - Faulty blower motor resistor
 - Faulty blower motor circuit wiring or wire harness connectors.

DIAGNOSIS AND TESTING (Continued)

VIBRATION

Possible causes of blower motor vibration include:

- Improper blower motor mounting
- Improper blower wheel mounting
- Blower wheel out of balance or bent
- Blower motor faulty.

NOISE

To verify that the blower is the source of the noise, unplug the blower motor wire harness connector and operate the heater-A/C system. If the noise goes away, possible causes include:

- Foreign material in the heater-A/C housing
- Improper blower motor mounting
- Improper blower wheel mounting
- Blower motor faulty.

BLOWER MOTOR RELAY

WARNING: ON VEHICLES EQUIPPED WITH AIR-BAGS, REFER TO GROUP 8M - PASSIVE RESTRAINT SYSTEMS BEFORE ATTEMPTING ANY STEERING WHEEL, STEERING COLUMN, OR INSTRUMENT PANEL COMPONENT DIAGNOSIS OR SERVICE. FAILURE TO TAKE THE PROPER PRECAUTIONS COULD RESULT IN ACCIDENTAL AIR-BAG DEPLOYMENT AND POSSIBLE PERSONAL INJURY.

RELAY TEST

The blower motor relay (Fig. 7) is located in a wire harness connector that is secured to the heater-A/C housing behind the glove box on the passenger side of the vehicle, next to the heater-A/C wire harness connector in the passenger compartment. Remove the relay from its connector to perform the following tests:

- (1) A relay in the de-energized position should have continuity between terminals 87A and 30, and no continuity between terminals 87 and 30. If OK, go to Step 2. If not OK, replace the faulty relay.
- (2) Resistance between terminals 85 and 86 (electromagnet) should be 75 ± 5 ohms. If OK, go to Step 3. If not OK, replace the faulty relay.
- (3) Connect a battery to terminals 85 and 86. There should now be continuity between terminals 30 and 87, and no continuity between terminals 87A and 30. If OK, see the Relay Circuit Test procedure in this group. If not OK, replace the faulty relay.

RELAY CIRCUIT TEST

For circuit descriptions and diagrams, refer to 8W-42 - Air Conditioning/Heater in Group 8W - Wiring Diagrams.

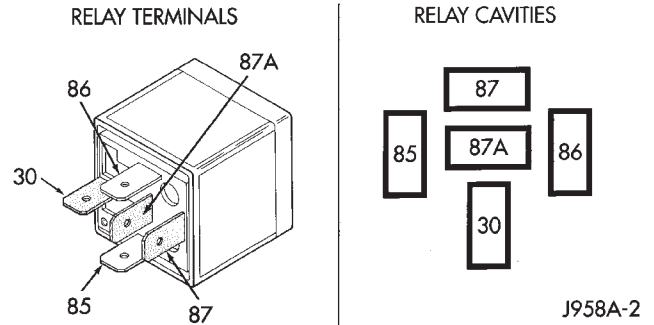

TERMINAL LEGEND	
NUMBER	IDENTIFICATION
30	COMMON FEED
85	COIL GROUND
86	COIL BATTERY
87	NORMALLY OPEN
87A	NORMALLY CLOSED

Fig. 7 Blower Motor Relay

(1) The relay common feed terminal cavity (30) is connected to fused battery feed directly from a fuse in the Power Distribution Center (PDC), and should be hot at all times. Check for battery voltage at the connector cavity for relay terminal 30. If OK, go to Step 2. If not OK, repair the open circuit to the PDC fuse as required.

(2) The relay normally closed terminal cavity (87A) is not used for this application. Go to Step 3.

(3) The relay normally open terminal cavity (87) is connected to the blower motor. When the relay is energized, terminal 87 is connected to terminal 30 and provides full battery current to the blower motor relay output circuit cavity of the blower motor wire harness connector at all times. If OK, go to Step 4. If not OK, repair the open circuit to the blower motor as required.

(4) The coil battery terminal cavity (86) is connected to the ignition switch. When the ignition switch is placed in the On position, fused ignition switch output is directed from a fuse in the junction block to the relay electromagnetic coil to energize the relay. There should be battery voltage at the connector cavity for relay terminal 86 with the ignition switch in the On position. If OK, go to Step 5. If not OK, repair the open circuit to the junction block fuse as required.

(5) The coil ground terminal cavity (85) is connected to ground. This terminal supplies the ground for the relay electromagnetic coil. There should be continuity between the connector cavity for relay termi-

DIAGNOSIS AND TESTING (Continued)

nal 85 and a good ground at all times. If not OK, repair the open circuit as required.

BLOWER MOTOR RESISTOR

For circuit descriptions and diagrams, refer to 8W-42 - Air Conditioning/Heater in Group 8W - Wiring Diagrams.

WARNING: ON VEHICLES EQUIPPED WITH AIR-BAGS, REFER TO GROUP 8M - PASSIVE RESTRAINT SYSTEMS BEFORE ATTEMPTING ANY STEERING WHEEL, STEERING COLUMN, OR INSTRUMENT PANEL COMPONENT DIAGNOSIS OR SERVICE. FAILURE TO TAKE THE PROPER PRECAUTIONS COULD RESULT IN ACCIDENTAL AIR-BAG DEPLOYMENT AND POSSIBLE PERSONAL INJURY.

(1) Disconnect and isolate the battery negative cable.

(2) Remove the kick cover from the heater-A/C housing and unplug the wire harness connector from the blower motor resistor.

(3) Check for continuity between each of the blower motor switch input terminals of the resistor and the resistor output terminal. In each case there should be continuity. If OK, repair the wire harness circuits between the blower motor switch and the blower motor resistor or blower motor relay as required. If not OK, replace the faulty blower motor resistor.

BLOWER MOTOR SWITCH

For circuit descriptions and diagrams, refer to 8W-42 - Air Conditioning/Heater in Group 8W - Wiring Diagrams.

WARNING: ON VEHICLES EQUIPPED WITH AIR-BAGS, REFER TO GROUP 8M - PASSIVE RESTRAINT SYSTEMS BEFORE ATTEMPTING ANY STEERING WHEEL, STEERING COLUMN, OR INSTRUMENT PANEL COMPONENT DIAGNOSIS OR SERVICE. FAILURE TO TAKE THE PROPER PRECAUTIONS COULD RESULT IN ACCIDENTAL AIR-BAG DEPLOYMENT AND POSSIBLE PERSONAL INJURY.

(1) Check for battery voltage at the fuse in the Power Distribution Center (PDC). If OK, go to Step 2. If not OK, repair the shorted circuit or component as required and replace the faulty fuse.

(2) Turn the ignition switch to the Off position. Disconnect and isolate the battery negative cable. Remove the heater-A/C control from the instrument panel. Check for continuity between the ground circuit cavity of the heater-A/C control wire harness connector and a good ground. There should be conti-

nunity. If OK, go to Step 3. If not OK, repair the open circuit to ground as required.

(3) With the heater-A/C control wire harness connector unplugged, place the heater-A/C mode control switch knob in any position except the Off position. Check for continuity between the ground circuit terminal and each of the blower motor driver circuit terminals of the heater-A/C control as you move the blower motor switch knob to each of the four speed positions. There should be continuity at each driver circuit terminal in only one blower motor switch speed position. If OK, test and repair the blower driver circuits between the heater-A/C control connector and the blower motor resistor as required. If not OK, replace the faulty heater-A/C control unit.

COMPRESSOR

When investigating an air conditioning related noise, you must first know the conditions under which the noise occurs. These conditions include: weather, vehicle speed, transmission in gear or neutral, engine speed, engine temperature, and any other special conditions. Noises that develop during air conditioning operation can often be misleading. For example: What sounds like a failed front bearing or connecting rod, may be caused by loose bolts, nuts, mounting brackets, or a loose compressor clutch assembly.

Drive belts are speed sensitive. At different engine speeds and depending upon belt tension, belts can develop noises that are mistaken for a compressor noise. Improper belt tension can cause a misleading noise when the compressor clutch is engaged, which may not occur when the compressor clutch is disengaged. Check the serpentine drive belt condition and tension as described in Group 7 - Cooling System before beginning this procedure.

(1) Select a quiet area for testing. Duplicate the complaint conditions as much as possible. Switch the compressor on and off several times to clearly identify the compressor noise. Listen to the compressor while the clutch is engaged and disengaged. Probe the compressor with an engine stethoscope or a long screwdriver with the handle held to your ear to better localize the source of the noise.

(2) Loosen all of the compressor mounting hardware and retighten. Tighten the compressor clutch mounting nut. Be certain that the clutch coil is mounted securely to the compressor, and that the clutch plate and pulley are properly aligned and have the correct air gap. See Compressor and Compressor Clutch in the Removal and Installation section of this group for the procedures.

(3) To duplicate a high-ambient temperature condition (high head pressure), restrict the air flow through the condenser. Install a manifold gauge set

DIAGNOSIS AND TESTING (Continued)

to be certain that the discharge pressure does not exceed 2760 kPa (400 psi).

(4) Check the refrigerant system plumbing for incorrect routing, rubbing or interference, which can cause unusual noises. Also check the refrigerant lines for kinks or sharp bends that will restrict refrigerant flow, which can cause noises. See Suction and Discharge Line in the Removal and Installation section of this group for more information.

(5) If the noise is from opening and closing of the high pressure relief valve, evacuate and recharge the refrigerant system. See Refrigerant System Evacuate and Refrigerant System Charge in the Service Procedures section of this group. If the high pressure relief valve still does not seat properly, replace the compressor.

(6) If the noise is from liquid slugging on the suction line, replace the accumulator. See Accumulator in the Removal and Installation section of this group for the procedures. Check the refrigerant oil level and the refrigerant system charge. See Refrigerant Oil Level and Refrigerant System Charge in the Service Procedures section of this group. If the liquid slugging condition continues following accumulator replacement, replace the compressor.

(7) If the noise continues, replace the compressor and repeat Step 1.

COMPRESSOR CLUTCH COIL

For circuit descriptions and diagrams, refer to 8W-42 - Air Conditioning/Heater in Group 8W - Wiring Diagrams. The battery must be fully-charged before performing the following tests. Refer to Group 8A - Battery for more information.

(1) Connect an ammeter (0 to 10 ampere scale) in series with the clutch coil terminal. Use a voltmeter (0 to 20 volt scale) with clip-type leads for measuring the voltage across the battery and the compressor clutch coil.

(2) With the heater-A/C mode control switch in any A/C mode, and the blower motor switch in the lowest speed position, start the engine and run it at normal idle.

(3) The compressor clutch coil voltage should read within two volts of the battery voltage. If there is voltage at the clutch coil, but the reading is not within two volts of the battery voltage, test the clutch coil feed circuit for excessive voltage drop and repair as required. If there is no voltage reading at the clutch coil, use a DRB scan tool and the proper Diagnostic Procedures manual for testing of the compressor clutch circuit. The following components must be checked and repaired as required before you can complete testing of the clutch coil:

- Fuses in the junction block and the Power Distribution Center (PDC)

- Heater-A/C mode control switch
- Compressor clutch relay
- High pressure cut-off switch
- Low pressure cycling clutch switch
- Powertrain Control Module (PCM).

(4) The compressor clutch coil is acceptable if the current draw measured at the clutch coil is 2.0 to 3.9 amperes with the electrical system voltage at 11.5 to 12.5 volts. This should only be checked with the work area temperature at 21° C (70° F). If system voltage is more than 12.5 volts, add electrical loads by turning on electrical accessories until the system voltage drops below 12.5 volts.

(a) If the clutch coil current reading is four amperes or more, the coil is shorted and should be replaced.

(b) If the clutch coil current reading is zero, the coil is open and should be replaced.

COMPRESSOR CLUTCH RELAY**RELAY TEST**

The compressor clutch relay (Fig. 8) is located in the Power Distribution Center (PDC). Refer to the PDC label for relay identification and location. Remove the relay from the PDC to perform the following tests:

(1) A relay in the de-energized position should have continuity between terminals 87A and 30, and no continuity between terminals 87 and 30. If OK, go to Step 2. If not OK, replace the faulty relay.

(2) Resistance between terminals 85 and 86 (electromagnet) should be 75 ± 5 ohms. If OK, go to Step 3. If not OK, replace the faulty relay.

(3) Connect a battery to terminals 85 and 86. There should now be continuity between terminals 30 and 87, and no continuity between terminals 87A and 30. If OK, see Relay Circuit Test in the Diagnosis and Testing section of this group. If not OK, replace the faulty relay.

RELAY CIRCUIT TEST

For circuit descriptions and diagrams, refer to 8W-42 - Air Conditioning/Heater in Group 8W - Wiring Diagrams.

(1) The relay common feed terminal cavity (30) is connected to fused battery feed. There should be battery voltage at the cavity for relay terminal 30 at all times. If OK, go to Step 2. If not OK, repair the open circuit to the fuse in the PDC as required.

(2) The relay normally closed terminal (87A) is not used in this application. Go to Step 3.

(3) The relay normally open terminal cavity (87) is connected to the compressor clutch coil. There should be continuity between this cavity and the A/C compressor clutch relay output circuit cavity of the com-

DIAGNOSIS AND TESTING (Continued)

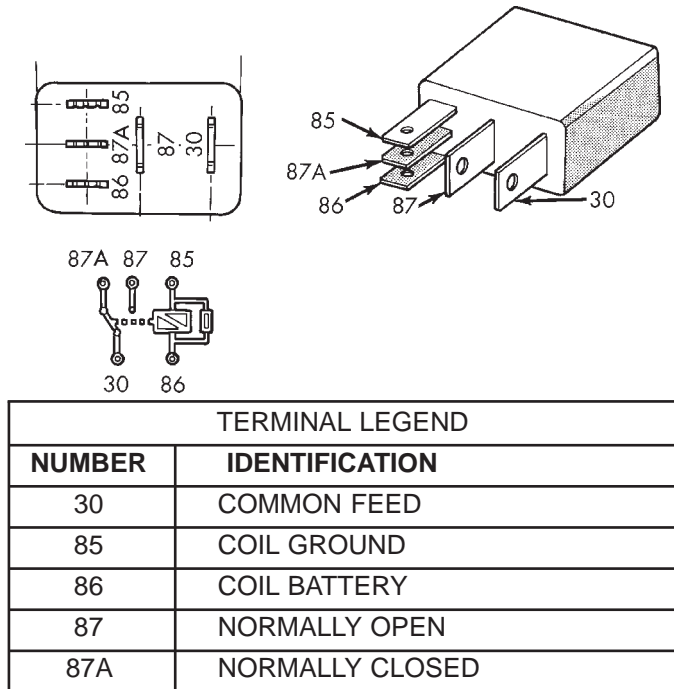

Fig. 8 Compressor Clutch Relay

pressor clutch coil wire harness connector. If OK, go to Step 4. If not OK, repair the open circuit as required.

(4) The relay coil battery terminal (86) is connected to the fused ignition switch output (run/start) circuit. There should be battery voltage at the cavity for relay terminal 86 with the ignition switch in the On position. If OK, go to Step 5. If not OK, repair the open circuit to the fuse in the junction block as required.

(5) The coil ground terminal cavity (85) is switched to ground through the Powertrain Control Module (PCM). There should be continuity between this cavity and the A/C compressor clutch relay control circuit cavity of the PCM wire harness connector C (gray) at all times. If not OK, repair the open circuit as required.

**DUAL FUNCTION HIGH PRESSURE SWITCH/
HIGH PRESSURE CUT-OFF SWITCH**

Before performing diagnosis of the dual function high pressure switch, or the high pressure cut-off switch, verify that the refrigerant system has the correct refrigerant charge. See Refrigerant System Charge in the Service Procedures section of this group for more information.

For circuit descriptions and diagrams, refer to 8W-42 - Air Conditioning/Heater in Group 8W - Wiring Diagrams.

(1) Disconnect and isolate the battery negative cable.

(2) Unplug the high pressure switch wire harness connector from the switch on the refrigerant system fitting.

(3) On the dual function high pressure switch, check for continuity between terminals C and D. On the two terminal switch, check for continuity between both terminals of the high pressure cut-off switch. There should be continuity. If OK, test and repair the A/C switch sense circuit as required. If not OK, replace the faulty switch.

HEATER PERFORMANCE

Before performing the following tests, refer to Group 7 - Cooling System for the procedures to check the radiator coolant level, serpentine drive belt tension, radiator air flow and the radiator fan operation. Also be certain that the accessory vacuum supply line is connected at the engine intake manifold.

MAXIMUM HEATER OUTPUT

Engine coolant is delivered to the heater core through two heater hoses. With the engine idling at normal operating temperature, set the temperature control knob in the full hot position, the mode control switch knob in the floor heat position, and the blower motor switch knob in the highest speed position. Using a test thermometer, check the temperature of the air being discharged at the heater-A/C housing floor outlets. Compare the test thermometer reading to the Temperature Reference chart.

Temperature Reference				
Ambient Air Temperature	15.5° C (60° F)	21.1° C (70° F)	26.6° C (80° F)	32.2° C (90° F)
Minimum Air Temperature at Floor Outlet	62.2° C (144° F)	63.8° C (147° F)	65.5° C (150° F)	67.2° C (153° F)

DIAGNOSIS AND TESTING (Continued)

If the floor outlet air temperature is too low, refer to Group 7 - Cooling System to check the engine coolant temperature specifications. Both of the heater hoses should be hot to the touch. The coolant return heater hose should be slightly cooler than the coolant supply heater hose. If the return hose is much cooler than the supply hose, locate and repair the engine coolant flow obstruction in the cooling system. Refer to Group 7 - Cooling System for the procedures.

OBSTRUCTED COOLANT FLOW Possible locations or causes of obstructed coolant flow:

- Pinched or kinked heater hoses.
- Improper heater hose routing.
- Plugged heater hoses or supply and return ports at the cooling system connections.
- A plugged heater core.

If proper coolant flow through the cooling system is verified, and heater outlet air temperature is still low, a mechanical problem may exist.

MECHANICAL PROBLEMS Possible locations or causes of insufficient heat:

- An obstructed cowl air intake.
- Obstructed heater system outlets.
- A blend-air door not functioning properly.

TEMPERATURE CONTROL

If the heater outlet air temperature cannot be adjusted with the temperature control knob on the heater-A/C control panel, the following could require service:

- The heater-A/C control.
- The temperature control motor.
- The blend-air door.
- Improper engine coolant temperature.

LOW PRESSURE CYCLING CLUTCH SWITCH

Before performing diagnosis of the low pressure cycling clutch switch, be certain that the switch is properly installed on the accumulator fitting. If the switch is too loose it may not open the Schrader-type valve in the accumulator fitting, which will prevent the switch from correctly monitoring the refrigerant system pressure. Remember that lower ambient temperatures, below about -1°C (30°F), during cold weather will open the switch contacts and prevent compressor operation due to the pressure/temperature relationship of the refrigerant.

Also verify that the refrigerant system has the correct refrigerant charge. See Refrigerant System Charge in the Service Procedures section of this group for more information.

For circuit descriptions and diagrams, refer to 8W-42 - Air Conditioning/Heater in Group 8W - Wiring Diagrams.

(1) Disconnect and isolate the battery negative cable.

(2) Unplug the low pressure cycling clutch switch wire harness connector from the switch on the accumulator fitting.

(3) Install a jumper wire between the two cavities of the low pressure cycling clutch switch wire harness connector.

(4) Connect a manifold gauge set to the refrigerant system service ports. See Refrigerant System Service Equipment and Refrigerant System Service Ports in the Description and Operation section of this group for more information.

(5) Connect the battery negative cable.

(6) Place the heater-A/C mode control switch knob in any A/C position and start the engine.

(7) Check for continuity between the two terminals of the low pressure cycling clutch switch. There should be continuity with a suction pressure reading of 262 kPa (38 psi) or above, and no continuity with a suction pressure reading of 141 kPa (20.5 psi) or below. If OK, test and repair the A/C switch sense circuit as required. If not OK, replace the faulty switch.

REFRIGERANT SYSTEM LEAKS

WARNING: REVIEW THE WARNINGS AND CAUTIONS IN THE FRONT OF THIS GROUP BEFORE LEAK TESTING THE SYSTEM.

If the air conditioning system is not cooling properly, determine if the refrigerant system is fully-charged. See A/C Performance in this group for the procedures. If the refrigerant system is low or empty; a leak at a refrigerant line, connector fitting, component, or component seal is likely.

An electronic leak detector designed for R-134a refrigerant, or a fluorescent R-134a leak detection dye and a black light are recommended for locating and confirming refrigerant system leaks. Refer to the operating instructions supplied by the equipment manufacturer for proper care and use of this equipment.

An oily residue on or near refrigerant system lines, connector fittings, components, or component seals can indicate the general location of a possible refrigerant leak. However, the exact leak location should be confirmed with an electronic leak detector prior to component repair or replacement.

To detect a leak in the refrigerant system with an electronic leak detector, perform one of the following procedures:

SYSTEM EMPTY

(1) Evacuate the refrigerant system. See Refrigerant System Evacuate in this group for the procedures.

DIAGNOSIS AND TESTING (Continued)

(2) Connect and dispense 0.283 kilograms (0.625 pounds or 10 ounces) of R-134a refrigerant into the evacuated refrigerant system. See Refrigerant System Charge in this group for the procedures.

(3) Position the vehicle in a wind-free work area. This will aid in detecting small leaks.

(4) With the engine not running, use a electronic R-134a leak detector and search for leaks. Because R-134a refrigerant is heavier than air, the leak detector probe should be moved slowly along the bottom side of all refrigerant lines, connector fittings and components.

(5) To inspect the evaporator coil for leaks, insert the electronic leak detector probe into the center instrument panel outlet. Set the blower motor switch to the lowest speed position, and the mode control switch in the recirculation mode.

SYSTEM LOW

(1) Position the vehicle in a wind-free work area. This will aid in detecting small leaks.

(2) Bring the refrigerant system up to operating temperature and pressure. This is done by allowing the engine to run with the air conditioning system turned on for five minutes.

(3) With the engine not running, use a electronic R-134a leak detector and search for leaks. Because R-134a refrigerant is heavier than air, the leak detector probe should be moved slowly along the bottom side of all refrigerant lines, connector fittings and components.

(4) To inspect the evaporator coil for leaks, insert the electronic leak detector probe into the center instrument panel outlet. Set the blower motor switch to the lowest speed position, and the mode control switch in the recirculation mode.

VACUUM SYSTEM

Vacuum control is used to operate the mode doors in the heater-only and heater-A/C housings. Testing of the heater-only and heater-A/C mode control switch operation will determine if the vacuum, electrical, and mechanical controls are functioning. However, it is possible that a vacuum control system that operates perfectly at engine idle (high engine vacuum) may not function properly at high engine speeds or loads (low engine vacuum). This can be caused by leaks in the vacuum system, or a faulty vacuum check valve.

A vacuum system test will help to identify the source of poor vacuum system performance or vacuum system leaks. Before starting this test, stop the engine and make certain that the problem is not a disconnected vacuum supply tube at the engine intake manifold vacuum tap or at the vacuum reservoir.

Use an adjustable vacuum test set (Special Tool C-3707-B) and a suitable vacuum pump to test the heater-A/C vacuum control system. With a finger placed over the end of the vacuum test hose probe (Fig. 9), adjust the bleed valve on the test set gauge to obtain a vacuum of exactly 27 kPa (8 in. Hg.). Release and block the end of the probe several times to verify that the vacuum reading returns to the exact 27 kPa (8 in. Hg.) setting. Otherwise, a false reading will be obtained during testing.

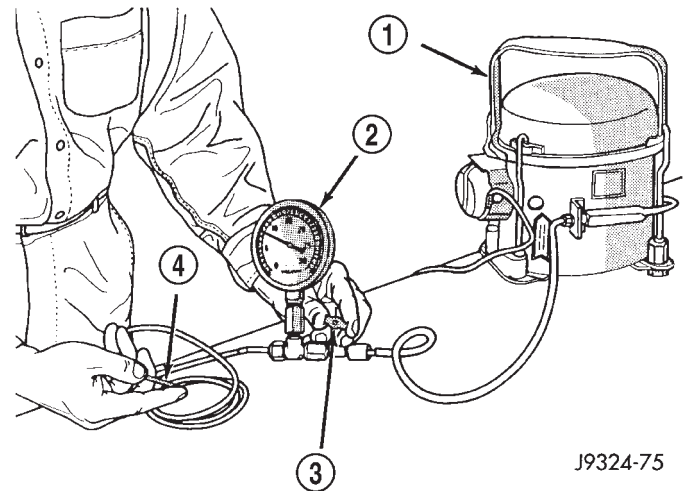

Fig. 9 Adjust Vacuum Test Bleed Valve

- 1 - VACUUM PUMP TOOL C-4289
- 2 - VACUUM TEST SET C-3707
- 3 - BLEED VALVE
- 4 - PROBE

VACUUM CHECK VALVE

(1) Remove the vacuum check valve. The valve is located in the vacuum supply tube (black) at the heater-A/C system vacuum tee.

(2) Connect the test set vacuum supply hose to the heater-A/C control side of the valve. When connected to this side of the check valve, no vacuum should pass and the test set gauge should return to the 27 kPa (8 in. Hg.) setting. If OK, go to Step 3. If not OK, replace the faulty valve.

(3) Connect the test set vacuum supply hose to the engine vacuum side of the valve. When connected to this side of the check valve, vacuum should flow through the valve without restriction. If not OK, replace the faulty valve.

HEATER-A/C CONTROLS

(1) Connect the test set vacuum probe to the heater-A/C vacuum supply (black) tube at the tee in the engine compartment. Position the test set gauge so that it can be viewed from the passenger compartment.

DIAGNOSIS AND TESTING (Continued)

(2) Place the heater-A/C mode control switch knob in each mode position, one position at a time, and pause after each selection. The test set gauge should return to the 27 kPa (8 in. Hg.) setting shortly after each selection is made. If not OK, a component or vacuum line in the vacuum circuit of the selected mode has a leak. See the procedure in Locating Vacuum Leaks.

CAUTION: Do not use lubricant on the switch ports or in the holes in the plug, as lubricant will ruin the vacuum valve in the switch. A drop of clean water in the connector plug holes will help the connector slide onto the switch ports.

LOCATING VACUUM LEAKS

WARNING: ON VEHICLES EQUIPPED WITH AIR-BAGS, REFER TO GROUP 8M - PASSIVE RESTRAINT SYSTEMS BEFORE ATTEMPTING ANY STEERING WHEEL, STEERING COLUMN, OR INSTRUMENT PANEL COMPONENT DIAGNOSIS OR SERVICE. FAILURE TO TAKE THE PROPER PRECAUTIONS COULD RESULT IN ACCIDENTAL AIR-BAG DEPLOYMENT AND POSSIBLE PERSONAL INJURY.

(1) Disconnect the vacuum harness connector behind the glove box and inboard of the glove box opening on the heater-A/C housing.

(2) Connect the test set vacuum hose probe to each port in the heater-A/C housing half of the vacuum harness connector, one port at a time, and pause after each connection (Fig. 10). The test set gauge should return to the 27 kPa (8 in. Hg.) setting shortly after each connection is made. If OK, replace the faulty heater-A/C control. If not OK, go to Step 3.

(3) Determine the vacuum line color of the vacuum circuit that is leaking. To determine the vacuum line colors, refer to the Vacuum Circuits chart (Fig. 11) or (Fig. 12).

(4) Disconnect and plug the vacuum line from the component (fitting, actuator, valve, switch, or reservoir) on the other end of the leaking circuit. Instrument panel disassembly or removal may be necessary to gain access to some components. See the service procedures in this group.

(5) Connect the test set hose or probe to the open end of the leaking circuit. The test set gauge should return to the 27 kPa (8 in. Hg.) setting shortly after each connection is made. If OK, replace the faulty disconnected component. If not OK, go to Step 6.

(6) To locate a leak in a vacuum line, leave one end of the line plugged and connect the test set hose or probe to the other end of the line. Run your fingers slowly along the line while watching the test set

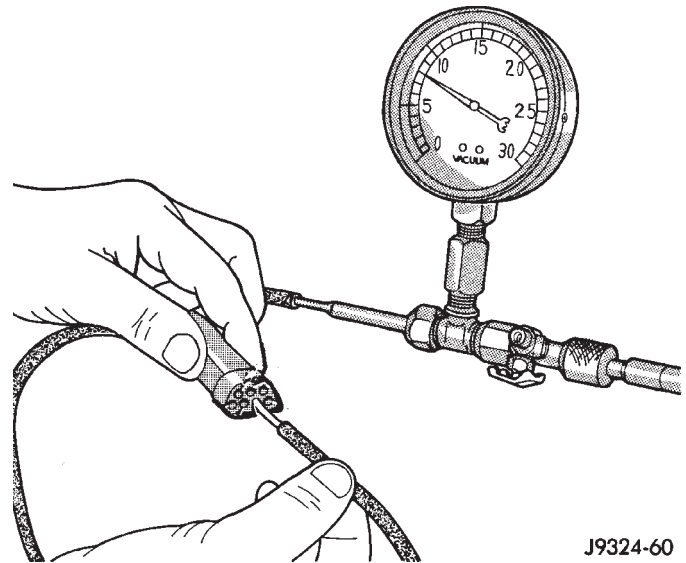

Fig. 10 Vacuum Circuit Test

gauge. The vacuum reading will fluctuate when your fingers contact the source of the leak. To repair the vacuum line, cut out the leaking section of the line. Then, insert the loose ends of the line into a suitable length of 3 millimeter (0.125 inch) inside diameter rubber hose.

SERVICE PROCEDURES

REFRIGERANT OIL LEVEL

When an air conditioning system is assembled at the factory, all components except the compressor are refrigerant oil free. After the refrigerant system has been charged and operated, the refrigerant oil in the compressor is dispersed throughout the refrigerant system. The accumulator, evaporator, condenser, and compressor will each retain a significant amount of the needed refrigerant oil.

It is important to have the correct amount of oil in the refrigerant system. This ensures proper lubrication of the compressor. Too little oil will result in damage to the compressor. Too much oil will reduce the cooling capacity of the air conditioning system.

It will not be necessary to check the oil level in the compressor or to add oil, unless there has been an oil loss. An oil loss may occur due to a rupture or leak from a refrigerant line, a connector fitting, a component, or a component seal. If a leak occurs, add 30 milliliters (1 fluid ounce) of refrigerant oil to the refrigerant system after the repair has been made. Refrigerant oil loss will be evident at the leak point by the presence of a wet, shiny surface around the leak.

Refrigerant oil must be added when an accumulator, evaporator coil, or condenser are replaced. See the Refrigerant Oil Capacities chart. When a compressor

SERVICE PROCEDURES (Continued)

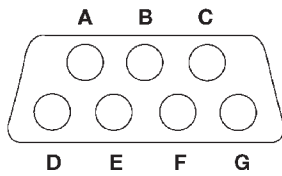

VACUUM CIRCUIT LEGEND		
I. D.	Function	Color
A	Not Used	N/A
B	Defrost Actuator (Full Position)	Yellow
C	Floor Actuator	Brown
D	Defrost Actuator (Mid-Position)	Blue
E	Vacuum Supply (Reservoir)	Black
F	Panel Actuator	Red
G	Not Used	N/A

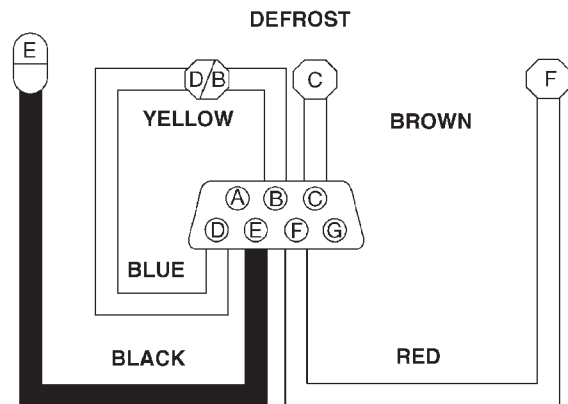
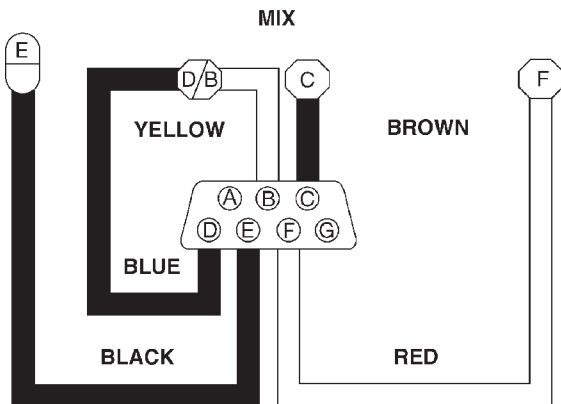
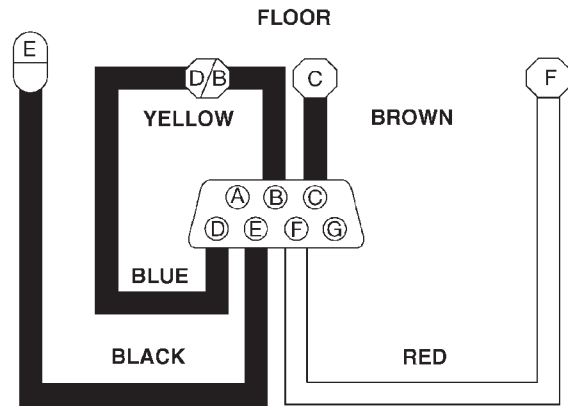
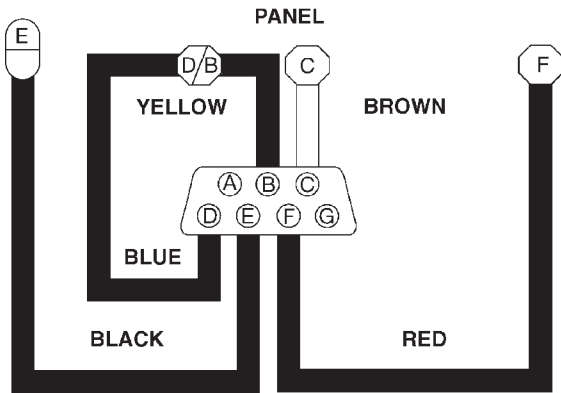
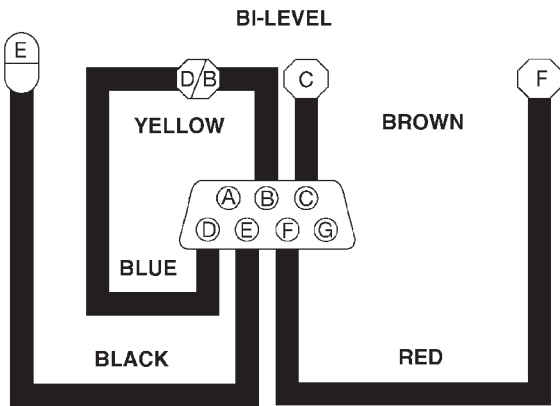
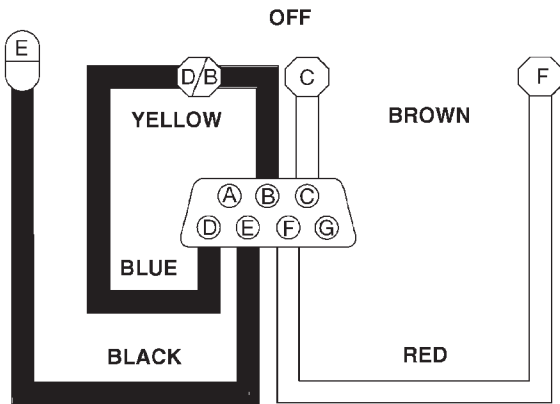

80aac2d2

Fig. 11 Vacuum Circuits - Heater Only

SERVICE PROCEDURES (Continued)

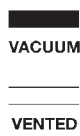
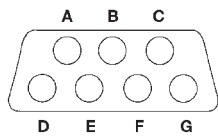

VACUUM CIRCUIT LEGEND		
I. D.	Function	Color
A	Not Used	N/A
B	Defrost Actuator (Full Position)	Yellow
C	Floor Actuator	Brown
D	Defrost Actuator (Mid-Position)	Blue
E	Vacuum Supply (Reservoir)	Black
F	Panel Actuator	Red
G	Recirculation Actuator	Green

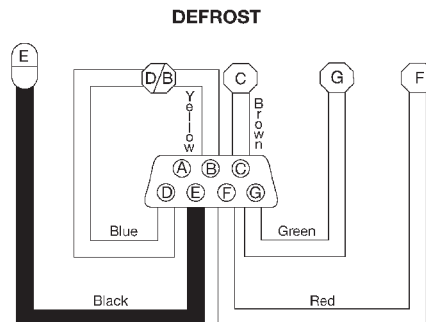
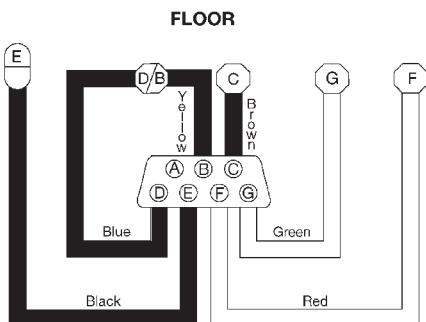
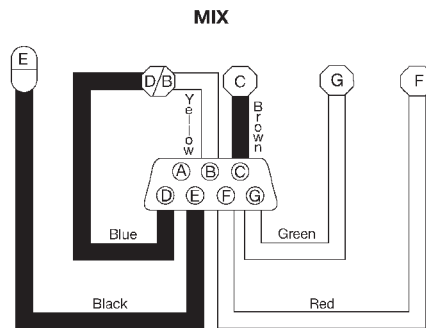
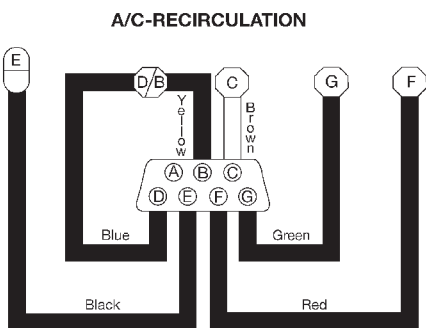
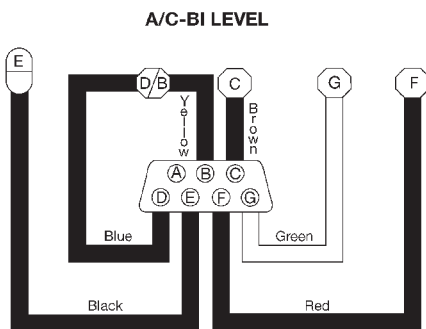
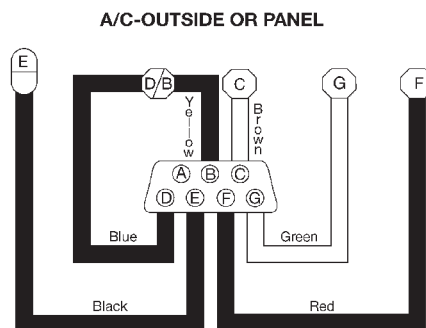
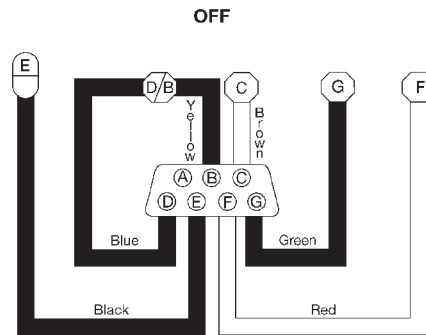

Fig. 12 Vacuum Circuits - Heater-A/C

SERVICE PROCEDURES (Continued)

is replaced, the refrigerant oil must be drained from the old compressor and measured. Drain all of the refrigerant oil from the new compressor, then fill the new compressor with the same amount of refrigerant oil that was drained out of the old compressor.

Refrigerant Oil Capacities		
Component	ml	fl oz
A/C System	180	6.1
Accumulator	90	3
Condenser	22	.75
Evaporator	45	1.5
Compressor	drain and measure the oil from the old compressor as noted	

REFRIGERANT RECOVERY

WARNING: REVIEW THE WARNINGS AND CAUTIONS IN THE GENERAL INFORMATION SECTION NEAR THE FRONT OF THIS GROUP BEFORE RECOVERING REFRIGERANT.

A R-134a refrigerant recovery/recycling/charging station that meets SAE Standard J2210 must be used to recover the refrigerant from an R-134a refrigerant system. Refer to the operating instructions supplied by the equipment manufacturer for the proper care and use of this equipment.

REFRIGERANT SYSTEM EVACUATE

WARNING: REVIEW THE WARNINGS AND CAUTIONS IN THE GENERAL INFORMATION SECTION NEAR THE FRONT OF THIS GROUP BEFORE EVACUATING THE SYSTEM.

If the refrigerant system has been open to the atmosphere, it must be evacuated before the system can be charged. If moisture and air enters the system and becomes mixed with the refrigerant, the compressor head pressure will rise above acceptable operating levels. This will reduce the performance of the air conditioner and damage the compressor. Evacuating the refrigerant system will remove the air and boil the moisture out of the system at near room temperature. To evacuate the refrigerant system, use the following procedure:

(1) Connect a R-134a refrigerant recovery/recycling/charging station that meets SAE Standard J2210 and a manifold gauge set to the refrigerant system of the vehicle.

(2) Open the low and high side valves and start the charging station vacuum pump. When the suction gauge reads 88 kPa (26 in. Hg.) vacuum or

greater, close all of the valves and turn off the vacuum pump.

(a) If the refrigerant system fails to reach the specified vacuum, the system has a leak that must be corrected. See Refrigerant System Leaks in the Diagnosis and Testing section of this group for the procedures.

(b) If the refrigerant system maintains the specified vacuum for five minutes, restart the vacuum pump, open the suction and discharge valves and evacuate the system for an additional ten minutes.

(3) Close all of the valves, and turn off the charging station vacuum pump.

(4) The refrigerant system is now ready to be charged with R-134a refrigerant. See Refrigerant System Charge in the Service Procedures section of this group.

REFRIGERANT SYSTEM CHARGE

WARNING: REVIEW THE WARNINGS AND CAUTIONS IN THE FRONT OF THIS GROUP BEFORE CHARGING THE REFRIGERANT SYSTEM.

After the refrigerant system has been tested for leaks and evacuated, a refrigerant charge can be injected into the system. See Refrigerant Charge Capacity for the proper amount of the refrigerant charge.

A R-134a refrigerant recovery/recycling/charging station that meets SAE Standard J2210 must be used to charge the refrigerant system with R-134a refrigerant. Refer to the operating instructions supplied by the equipment manufacturer for proper care and use of this equipment.

REFRIGERANT CHARGE CAPACITY

The R-134a refrigerant system charge capacity for this vehicle is 0.567 kilograms (1.25 pounds).

REFRIGERANT SYSTEM SERVICE EQUIPMENT

WARNING: EYE PROTECTION MUST BE WORN WHEN SERVICING AN AIR CONDITIONING REFRIGERANT SYSTEM. TURN OFF (ROTATE CLOCKWISE) ALL VALVES ON THE EQUIPMENT BEING USED, BEFORE CONNECTING TO OR DISCONNECTING FROM THE REFRIGERANT SYSTEM. FAILURE TO OBSERVE THESE WARNINGS MAY RESULT IN PERSONAL INJURY.

When servicing the air conditioning system, a R-134a refrigerant recovery/recycling/charging station that meets SAE Standard J2210 must be used. Contact an automotive service equipment supplier for refrigerant recovery/recycling/charging equipment. Refer to the operating instructions supplied by the

SERVICE PROCEDURES (Continued)

equipment manufacturer for proper care and use of this equipment.

A manifold gauge set may be needed with some recovery/recycling/charging equipment (Fig. 13). The service hoses on the gauge set being used should have manual (turn wheel), or automatic back-flow valves at the service port connector ends. This will prevent refrigerant from being released into the atmosphere.

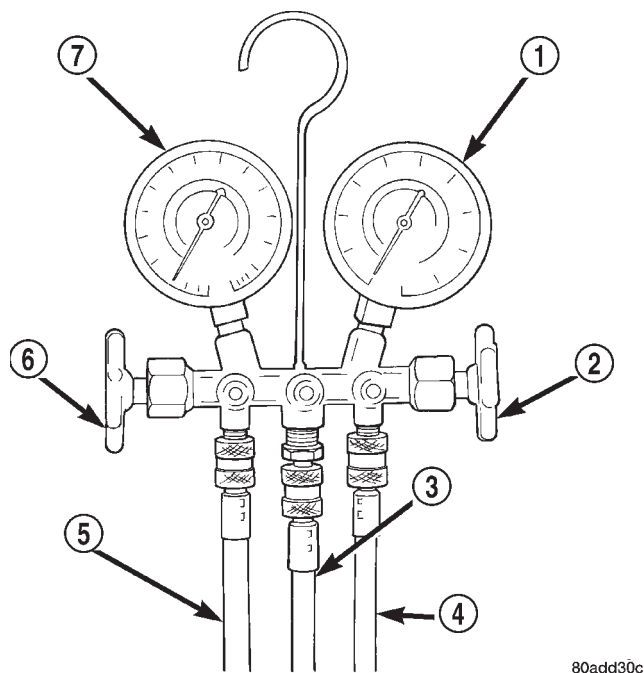

80add30c

Fig. 13 Manifold Gauge Set - Typical

- 1 - HIGH PRESSURE GAUGE
- 2 - VALVE
- 3 - VACUUM/REFRIGERANT HOSE (YELLOW W/BLACK STRIPE)
- 4 - HIGH PRESSURE HOSE (RED W/BLACK STRIPE)
- 5 - LOW PRESSURE HOSE (BLUE W/BLACK STRIPE)
- 6 - VALVE
- 7 - LOW PRESSURE GAUGE

MANIFOLD GAUGE SET CONNECTIONS

CAUTION: Do not use an R-12 manifold gauge set on an R-134a system. The refrigerants are not compatible and system damage will result.

LOW PRESSURE GAUGE HOSE The low pressure hose (Blue with Black stripe) attaches to the suction service port. This port is located on the suction line between the accumulator outlet and the compressor.

HIGH PRESSURE GAUGE HOSE The high pressure hose (Red with Black stripe) attaches to the discharge service port. This port is located on the discharge line between the compressor and the condenser inlet.

RECOVERY/RECYCLING/EVACUATION/CHARGING HOSE The center manifold hose (Yellow, or White, with Black stripe) is used to recover, evacuate, and charge the refrigerant system. When the low or high pressure valves on the manifold gauge set are opened, the refrigerant in the system will escape through this hose.

REMOVAL AND INSTALLATION

SERVICE WARNINGS AND PRECAUTIONS

WARNING:

- THE AIR CONDITIONING SYSTEM CONTAINS REFRIGERANT UNDER HIGH PRESSURE. SEVERE PERSONAL INJURY MAY RESULT FROM IMPROPER SERVICE PROCEDURES. REPAIRS SHOULD ONLY BE PERFORMED BY QUALIFIED SERVICE PERSONNEL.

- AVOID BREATHING THE REFRIGERANT AND REFRIGERANT OIL VAPOR OR MIST. EXPOSURE MAY IRRITATE THE EYES, NOSE, AND/OR THROAT. WEAR EYE PROTECTION WHEN SERVICING THE AIR CONDITIONING REFRIGERANT SYSTEM. SERIOUS EYE INJURY CAN RESULT FROM DIRECT CONTACT WITH THE REFRIGERANT. IF EYE CONTACT OCCURS, SEEK MEDICAL ATTENTION IMMEDIATELY.

- DO NOT EXPOSE THE REFRIGERANT TO OPEN FLAME. POISONOUS GAS IS CREATED WHEN REFRIGERANT IS BURNED. AN ELECTRONIC LEAK DETECTOR IS RECOMMENDED.

- IF ACCIDENTAL SYSTEM DISCHARGE OCCURS, VENTILATE THE WORK AREA BEFORE RESUMING SERVICE. LARGE AMOUNTS OF REFRIGERANT RELEASED IN A CLOSED WORK AREA WILL DISPLACE THE OXYGEN AND CAUSE SUFFOCATION.

- THE EVAPORATION RATE OF R-134a REFRIGERANT AT AVERAGE TEMPERATURE AND ALTITUDE IS EXTREMELY HIGH. AS A RESULT, ANYTHING THAT COMES IN CONTACT WITH THE REFRIGERANT WILL FREEZE. ALWAYS PROTECT THE SKIN OR DELICATE OBJECTS FROM DIRECT CONTACT WITH THE REFRIGERANT.

- THE R-134a SERVICE EQUIPMENT OR THE VEHICLE REFRIGERANT SYSTEM SHOULD NOT BE PRESSURE TESTED OR LEAK TESTED WITH COMPRESSED AIR. SOME MIXTURES OF AIR AND R-134a HAVE BEEN SHOWN TO BE COMBUSTIBLE AT ELEVATED PRESSURES. THESE MIXTURES ARE POTENTIALLY DANGEROUS, AND MAY RESULT IN FIRE OR EXPLOSION CAUSING INJURY OR PROPERTY DAMAGE.

REMOVAL AND INSTALLATION (Continued)

CAUTION:

- Liquid refrigerant is corrosive to metal surfaces. Follow the operating instructions supplied with the service equipment being used.

- Never add R-12 to a refrigerant system designed to use R-134a. Damage to the system will result.

- R-12 refrigerant oil must not be mixed with R-134a refrigerant oil. They are not compatible.

- Do not use R-12 equipment or parts on the R-134a system. Damage to the system will result.

- Do not overcharge the refrigerant system. This will cause excessive compressor head pressure and can cause noise and system failure.

- Recover the refrigerant before opening any fitting or connection. Open the fittings with caution, even after the system has been discharged. Never open or loosen a connection before recovering the refrigerant.

- Do not remove the secondary retention clip from any spring-lock coupler connection while the refrigerant system is under pressure. Recover the refrigerant before removing the secondary retention clip. Open the fittings with caution, even after the system has been discharged. Never open or loosen a connection before recovering the refrigerant.

- The refrigerant system must always be evacuated before charging.

- Do not open the refrigerant system or uncap a replacement component until you are ready to service the system. This will prevent contamination in the system.

- Before disconnecting a component, clean the outside of the fittings thoroughly to prevent contamination from entering the refrigerant system.

- Immediately after disconnecting a component from the refrigerant system, seal the open fittings with a cap or plug.

- Before connecting an open refrigerant fitting, always install a new seal or gasket. Coat the fitting and seal with clean refrigerant oil before connecting.

- Do not remove the sealing caps from a replacement component until it is to be installed.

- When installing a refrigerant line, avoid sharp bends that may restrict refrigerant flow. Position the refrigerant lines away from exhaust system components or any sharp edges, which may damage the line.

- Tighten refrigerant fittings only to the specified torque. The aluminum fittings used in the refrigerant system will not tolerate overtightening.

- When disconnecting a refrigerant fitting, use a wrench on both halves of the fitting. This will prevent twisting of the refrigerant lines or tubes.

- Refrigerant oil will absorb moisture from the atmosphere if left uncapped. Do not open a container of refrigerant oil until you are ready to use it. Replace the cap on the oil container immediately after using. Store refrigerant oil only in a clean, airtight, and moisture-free container.

- Keep service tools and the work area clean. Contamination of the refrigerant system through careless work habits must be avoided.

COOLING SYSTEM REQUIREMENTS

To maintain the performance level of the heating-air conditioning system, the engine cooling system must be properly maintained. The use of a bug screen is not recommended. Any obstructions in front of the radiator or condenser will reduce the performance of the air conditioning and engine cooling systems.

The engine cooling system includes the heater core and the heater hoses. Refer to Group 7 - Cooling System for more information before the opening of, or attempting any service to the engine cooling system.

REFRIGERANT HOSES/LINES/TUBES**PRECAUTIONS**

Kinks or sharp bends in the refrigerant plumbing will reduce the capacity of the entire system. High pressures are produced in the system when it is operating. Extreme care must be exercised to make sure that all refrigerant system connections are pressure tight.

A good rule for the flexible hose refrigerant lines is to keep the radius of all bends at least ten times the diameter of the hose. Sharp bends will reduce the flow of refrigerant. The flexible hose lines should be routed so they are at least 80 millimeters (3 inches) from the exhaust manifold. It is a good practice to inspect all flexible refrigerant system hose lines at least once a year to make sure they are in good condition and properly routed.

There are two types of refrigerant fittings:

- All fittings with O-rings need to be coated with refrigerant oil before installation. Use only O-rings that are the correct size and approved for use with R-134a refrigerant. Failure to do so may result in a leak.

- Unified plumbing connections with gaskets cannot be serviced with O-rings. The gaskets are not reusable and new gaskets do not require lubrication before installing.

Using the proper tools when making a refrigerant plumbing connection is very important. Improper tools or improper use of the tools can damage the refrigerant fittings. Always use two wrenches when loosening or tightening tube fittings. Use one wrench

REMOVAL AND INSTALLATION (Continued)

to hold one side of the connection stationary, while loosening or tightening the other side of the connection with a second wrench.

The refrigerant must be recovered completely from the system before opening any fitting or connection. Open the fittings with caution, even after the refrigerant has been recovered. If any pressure is noticed as a fitting is loosened, tighten the fitting and recover the refrigerant from the system again.

Do not discharge refrigerant into the atmosphere. Use an R-134a refrigerant recovery/recycling device that meets SAE Standard J2210.

The refrigerant system will remain chemically stable as long as pure, moisture-free R-134a refrigerant and refrigerant oil is used. Dirt, moisture, or air can upset this chemical stability. Operational troubles or serious damage can occur if foreign material is present in the refrigerant system.

When it is necessary to open the refrigerant system, have everything needed to service the system ready. The refrigerant system should not be left open to the atmosphere any longer than necessary. Cap or plug all lines and fittings as soon as they are opened to prevent the entrance of dirt and moisture. All lines and components in parts stock should be capped or sealed until they are to be installed.

All tools, including the refrigerant recycling equipment, the manifold gauge set, and test hoses should be kept clean and dry. All tools and equipment must be designed for R-134a refrigerant.

ACCUMULATOR

WARNING: REVIEW THE WARNINGS AND CAUTIONS IN THE FRONT OF THIS GROUP BEFORE PERFORMING THE FOLLOWING OPERATION.

REMOVAL

(1) Disconnect and isolate the battery negative cable.

(2) Recover the refrigerant from the refrigerant system. See Refrigerant Recovery in this group for the procedures.

(3) Unplug the wire harness connector from the low pressure cycling clutch switch.

(4) Loosen the screw that secures the accumulator retaining band to the support bracket on the dash panel (Fig. 14).

(5) Disconnect the suction line from the accumulator outlet tube refrigerant line fitting. See Refrigerant Line Coupler in this group for the procedures. Install plugs in, or tape over all of the opened refrigerant line fittings.

(6) Disconnect the accumulator inlet tube refrigerant line fitting from the evaporator outlet tube. See Refrigerant Line Coupler in this group for the proce-

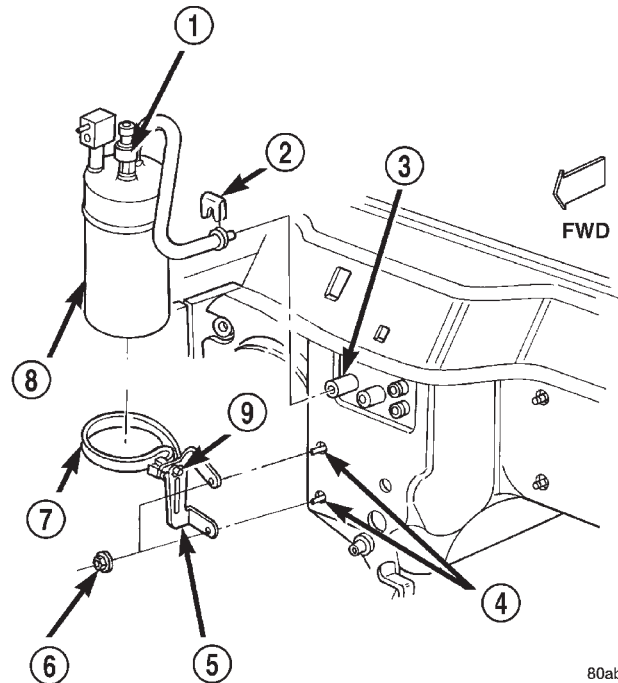

80abd2a5

Fig. 14 Accumulator Remove/Install

- 1 - LOW PRESSURE CYCLING CLUTCH SWITCH
- 2 - CLIP
- 3 - EVAPORATOR
- 4 - STUDS
- 5 - BRACKET
- 6 - NUTS
- 7 - BAND
- 8 - ACCUMULATOR
- 9 - SCREW

dures. Install plugs in, or tape over all of the opened refrigerant line fittings.

(7) Pull the accumulator and retaining band unit forward until the screw in the band is clear of the slotted hole in the support bracket on the dash panel.

(8) Remove the accumulator from the vehicle.

INSTALLATION

(1) Install the accumulator and retaining band as a unit by sliding the screw in the band into the slotted hole in the support bracket on the dash panel.

(2) Remove the tape or plugs from the refrigerant line fittings on the accumulator inlet tube and the evaporator outlet tube. Connect the accumulator inlet tube refrigerant line coupler to the evaporator outlet tube. See Refrigerant Line Coupler in this group for the procedures.

(3) Tighten the accumulator retaining band screw to 5 N·m (45 in. lbs.).

(4) Remove the tape or plugs from the refrigerant line fittings on the suction line and the accumulator outlet tube. Connect the suction line to the accumu-

REMOVAL AND INSTALLATION (Continued)

lator outlet tube refrigerant line coupler. See Refrigerant Line Coupler in this group for the procedures.

(5) Plug the wire harness connector into the low pressure cycling clutch switch.

(6) Connect the battery negative cable.

(7) Evacuate the refrigerant system. See Refrigerant System Evacuate in this group for the procedures.

(8) Charge the refrigerant system. See Refrigerant System Charge in this group for the procedures.

NOTE: If the accumulator is replaced, add 120 milliliters (4 fluid ounces) of refrigerant oil to the refrigerant system. Use only refrigerant oil of the type recommended for the compressor in the vehicle.

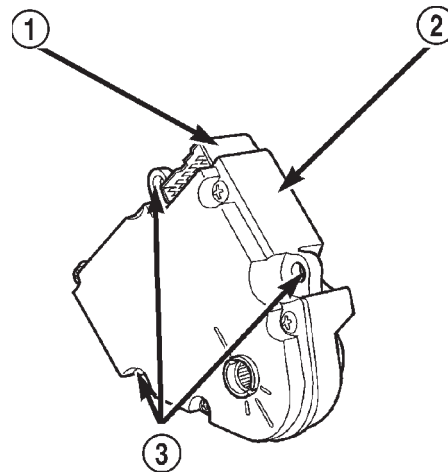

Fig. 15 Blend-Air Door Motor

- 1 - ELECTRICAL CONNECTOR
- 2 - BLEND-AIR DOOR MOTOR
- 3 - SCREW MOUNTING POINTS

80c073d9

BLEND-AIR DOOR MOTOR

WARNING: ON VEHICLES EQUIPPED WITH AIR-BAGS, REFER TO GROUP 8M - PASSIVE RESTRAINT SYSTEMS BEFORE ATTEMPTING ANY STEERING WHEEL, STEERING COLUMN, OR INSTRUMENT PANEL COMPONENT DIAGNOSIS OR SERVICE. FAILURE TO TAKE THE PROPER PRECAUTIONS COULD RESULT IN ACCIDENTAL AIR-BAG DEPLOYMENT AND POSSIBLE PERSONAL INJURY.

REMOVAL

(1) Disconnect and isolate the battery negative cable.

(2) Disconnect the wire connector from the blend-air door motor.

(3) Remove the screws that secure the blend-air door motor to the housing (Fig. 15).

(4) Remove the blend-air door motor.

INSTALLATION

(1) Reverse the removal procedures for installation.

(2) Install and tighten the screws that secures the blend-air door motor to the housing. Tighten the mounting screws to 1 N·m (10 in. lbs.).

(3) Connect the battery negative cable.

BLOWER MOTOR

REMOVAL

(1) If the vehicle is equipped with air conditioning, recover the refrigerant from the refrigerant system. See Refrigerant Recovery in this group for the procedures.

(2) Disconnect and isolate the battery negative cable.

(3) If the vehicle is equipped with air conditioning, the accumulator must be relocated in order to service the blower motor. This is done by loosening the accumulator retaining band screw and disconnecting the accumulator inlet tube from the evaporator outlet tube. The accumulator can then be moved far enough to access and remove the blower motor. See Accumulator in this group for the procedures.

(4) Unplug the blower motor wire harness connector (Fig. 16).

(5) Remove the three screws that secure the blower motor and wheel assembly to the heater-A/C housing.

(6) Rotate and tilt the blower motor unit as needed for clearance to remove the blower motor and wheel from the heater-A/C housing.

INSTALLATION

(1) Align and install the blower motor and wheel assembly into the heater-A/C housing.

(2) Install and tighten the three screws that secure the blower motor and wheel assembly to the heater-A/C housing. Tighten the mounting screws to 2.2 N·m (20 in. lbs.).

(3) Plug in the blower motor wire harness connector.

(4) If the vehicle is equipped with air conditioning, connect the accumulator inlet tube to the evaporator outlet tube and tighten the accumulator retaining band screw. See Accumulator in this group for the procedures.

(5) Connect the battery negative cable.

REMOVAL AND INSTALLATION (Continued)

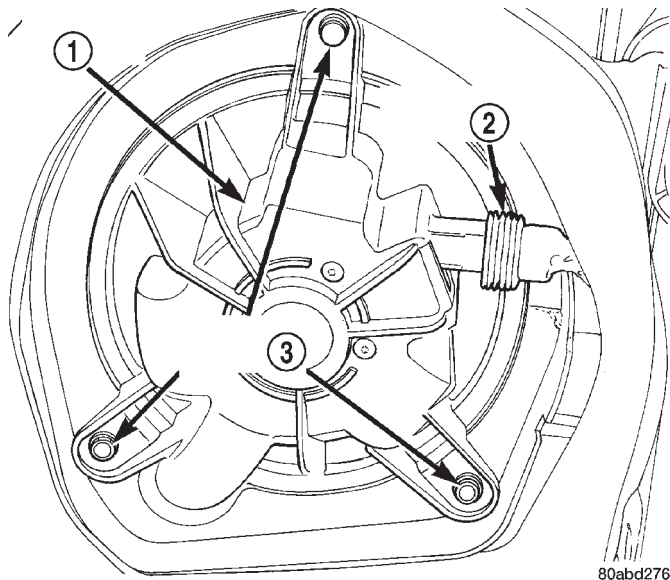
**Fig. 16 Blower Motor Remove/Install**

- 1 - BLOWER MOTOR
- 2 - WIRE HARNESS CONNECTOR
- 3 - MOUNTING SCREWS

(6) If the vehicle is equipped with air conditioning, evacuate the refrigerant system. See Refrigerant System Evacuate in this group for the procedures.

(7) If the vehicle is equipped with air conditioning, charge the refrigerant system. See Refrigerant System Charge in this group for the procedures.

BLOWER MOTOR RELAY

WARNING: ON VEHICLES EQUIPPED WITH AIR-BAGS, REFER TO GROUP 8M - PASSIVE RESTRAINT SYSTEMS BEFORE ATTEMPTING ANY STEERING WHEEL, STEERING COLUMN, OR INSTRUMENT PANEL COMPONENT DIAGNOSIS OR SERVICE. FAILURE TO TAKE THE PROPER PRECAUTIONS COULD RESULT IN ACCIDENTAL AIR-BAG DEPLOYMENT AND POSSIBLE PERSONAL INJURY.

(1) Disconnect and isolate the battery negative cable.

(2) Roll the glove box down from the instrument panel. Refer to Glove Box in Group 8E - Instrument Panel Systems for the procedures.

(3) Reach through the instrument panel glove box opening to locate the blower motor relay (Fig. 17).

(4) Unplug the blower motor relay from its wire harness connector.

(5) Install the blower motor relay by aligning the relay terminals with the cavities in the wire harness connector and pushing the relay firmly into place.

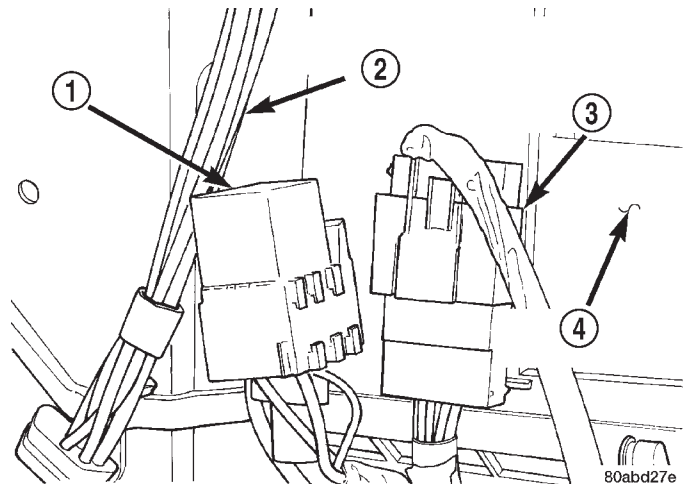
**Fig. 17 Blower Motor Relay Remove/Install**

- 1 - BLOWER MOTOR RELAY
- 2 - VACUUM HARNESS
- 3 - HEATER-A/C WIRE HARNESS CONNECTOR
- 4 - HEATER-A/C HOUSING

(6) Roll the glove box back up into the instrument panel. Refer to Glove Box in Group 8E - Instrument Panel Systems for the procedures.

(7) Connect the battery negative cable.

(8) Test the relay operation.

BLOWER MOTOR RESISTOR

WARNING: ON VEHICLES EQUIPPED WITH AIR-BAGS, REFER TO GROUP 8M - PASSIVE RESTRAINT SYSTEMS BEFORE ATTEMPTING ANY STEERING WHEEL, STEERING COLUMN, OR INSTRUMENT PANEL COMPONENT DIAGNOSIS OR SERVICE. FAILURE TO TAKE THE PROPER PRECAUTIONS COULD RESULT IN ACCIDENTAL AIR-BAG DEPLOYMENT AND POSSIBLE PERSONAL INJURY.

(1) Disconnect and isolate the battery negative cable.

(2) Remove the kick cover from the heater-A/C housing. See Kick Cover in this group for the procedures.

(3) Pull out the lock on the blower motor resistor wire harness connector to unlock the connector latch (Fig. 18).

(4) Depress the latch on the blower motor resistor wire harness connector and unplug the connector from the resistor.

(5) Remove the two screws that secure the resistor to the heater-A/C housing.

(6) Remove the resistor from the heater-A/C housing.

(7) Reverse the removal procedures to install. Tighten the mounting screws to 2.2 N·m (20 in lbs.).

REMOVAL AND INSTALLATION (Continued)

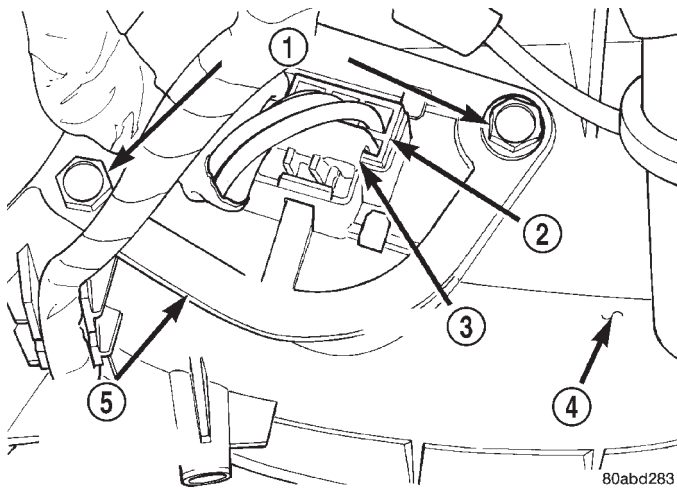

Fig. 18 Blower Motor Resistor Remove/Install

- 1 - SCREWS
- 2 - WIRE HARNESS CONNECTOR
- 3 - CONNECTOR LOCK
- 4 - HEATER-A/C HOUSING
- 5 - BLOWER MOTOR RESISTOR

COMPRESSOR

The compressor may be removed and repositioned without disconnecting the refrigerant lines or discharging the refrigerant system. Discharging is not necessary if servicing the compressor clutch or clutch coil, the engine, the cylinder head, or the generator.

WARNING: REVIEW THE WARNINGS AND CAUTIONS IN THE FRONT OF THIS GROUP BEFORE PERFORMING THE FOLLOWING OPERATION.

REMOVAL

(1) Recover the refrigerant from the refrigerant system. See Refrigerant Recovery in this group for the procedures.

(2) Disconnect and isolate the battery negative cable.

(3) Remove the serpentine drive belt. Refer to Group 7 - Cooling System for the procedures.

(4) Unplug the compressor clutch coil wire harness connector.

(5) Remove the suction and discharge refrigerant line manifold from the compressor. See Suction and Discharge Line in this group for the procedures. Install plugs in, or tape over all of the opened refrigerant fittings.

(6) Remove the four bolts that secure the compressor to the mounting bracket (Fig. 19).

(7) Remove the compressor from the mounting bracket.

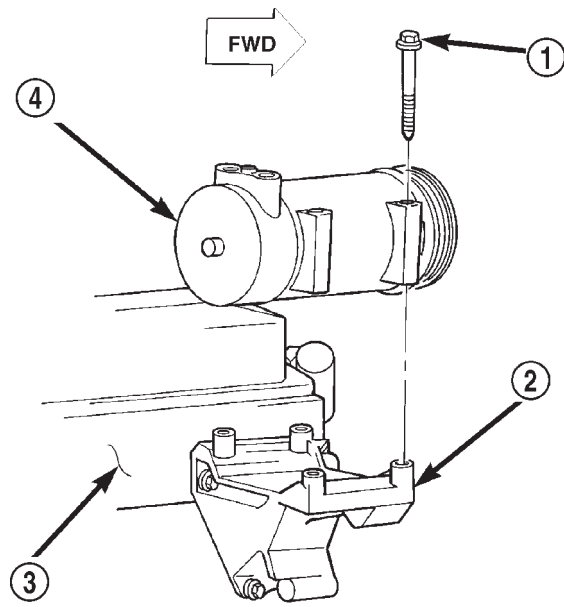

Fig. 19 Compressor Remove/Install - All 2.5L/4.0L Engines

- 1 - BOLT
- 2 - MOUNTING BRACKET
- 3 - ENGINE
- 4 - COMPRESSOR

INSTALLATION

NOTE: If a replacement compressor is being installed, be certain to check the refrigerant oil level. See Refrigerant Oil Level in this group for the procedures. Use only refrigerant oil of the type recommended for the compressor in the vehicle.

(1) Install the compressor to the mounting bracket. Tighten the four mounting bolts as follows:

- All 2.5L and 4.0L engines - 27 N·m (20 ft. lbs.)

(2) Remove the tape or plugs from all of the opened refrigerant line fittings. Install the suction and discharge line manifold to the compressor. See Suction and Discharge Line in this group for the procedures.

(3) Install the serpentine drive belt. Refer to Group 7 - Cooling System for the procedures.

(4) Plug in the compressor clutch coil wire harness connector.

(5) Connect the battery negative cable.

(6) Evacuate the refrigerant system. See Refrigerant System Evacuate in this group for the procedures.

(7) Charge the refrigerant system. See Refrigerant System Charge in this group for the procedures.

REMOVAL AND INSTALLATION (Continued)

COMPRESSOR CLUTCH

The refrigerant system can remain fully-charged during compressor clutch, pulley, or coil replacement. The compressor clutch can be serviced in the vehicle.

REMOVAL

- (1) Disconnect and isolate the battery negative cable.
- (2) Remove the serpentine drive belt. Refer to Group 7 - Cooling System for the procedures.
- (3) Unplug the compressor clutch coil wire harness connector.
- (4) Remove the four bolts that secure the compressor to the mounting bracket.
- (5) Remove the compressor from the mounting bracket. Support the compressor in the engine compartment while servicing the clutch.
- (6) Insert the two pins of the spanner wrench (Special Tool C-4489) into the holes of the clutch plate. Hold the clutch plate stationary and remove the hex nut (Fig. 20).

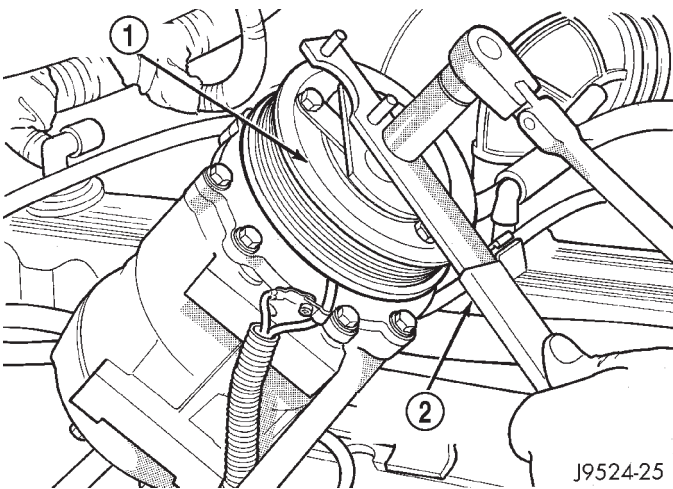
**Fig. 20 Clutch Nut Remove**

- 1 - CLUTCH PLATE
- 2 - SPANNER

- (7) Remove the clutch plate with a puller (Special Tool C-6461) (Fig. 21).

- (8) Remove the compressor shaft key and the clutch shims.

- (9) Remove the external front housing snap ring with snap ring pliers (Fig. 22).

- (10) Install the lip of the rotor puller (Special Tool C-6141-1) into the snap ring groove exposed in the previous step, and install the shaft protector (Special Tool C-6141-2) (Fig. 23).

- (11) Install the puller through-bolts (Special Tool C-6461) through the puller flange and into the jaws of the rotor puller and tighten (Fig. 24). Turn the

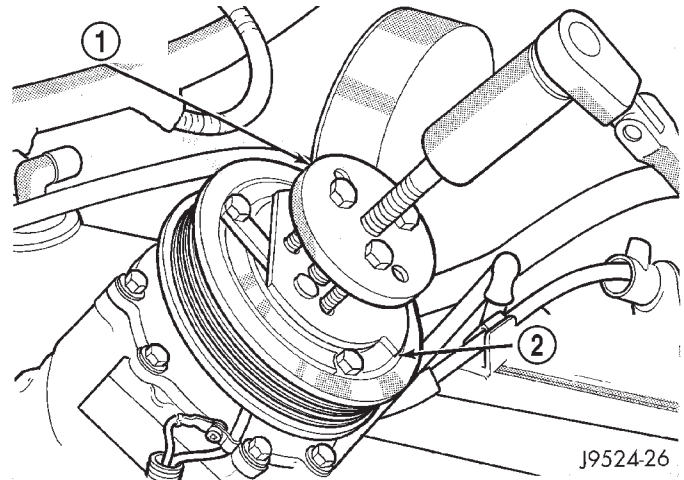
**Fig. 21 Clutch Plate Remove**

- 1 - CLUTCH PLATE PULLER
- 2 - CLUTCH PLATE

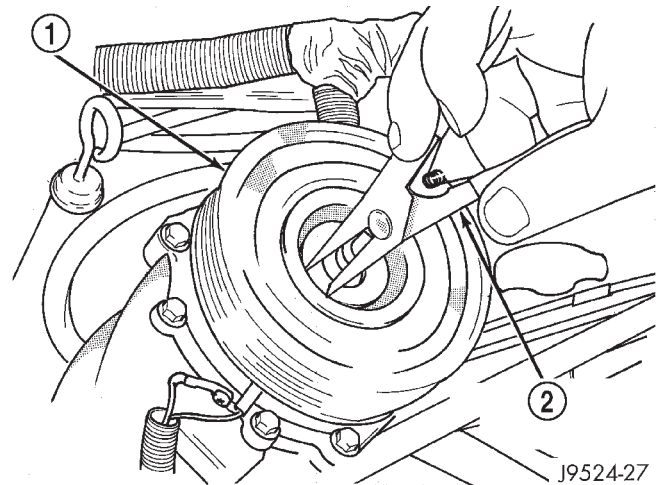
**Fig. 22 External Snap Ring Remove**

- 1 - PULLEY
- 2 - SNAP RING PLIERS

puller center bolt clockwise until the rotor pulley is free.

- (12) Remove the screw and retainer from the clutch coil lead wire harness on the compressor front housing (Fig. 25).

- (13) Remove the snap ring from the compressor hub and remove the clutch field coil (Fig. 26). Slide the clutch field coil off of the compressor hub.

INSPECTION

Examine the friction surfaces of the clutch pulley and the front plate for wear. The pulley and front plate should be replaced if there is excessive wear or scoring.

If the friction surfaces are oily, inspect the shaft and nose area of the compressor for oil. Remove the

REMOVAL AND INSTALLATION (Continued)

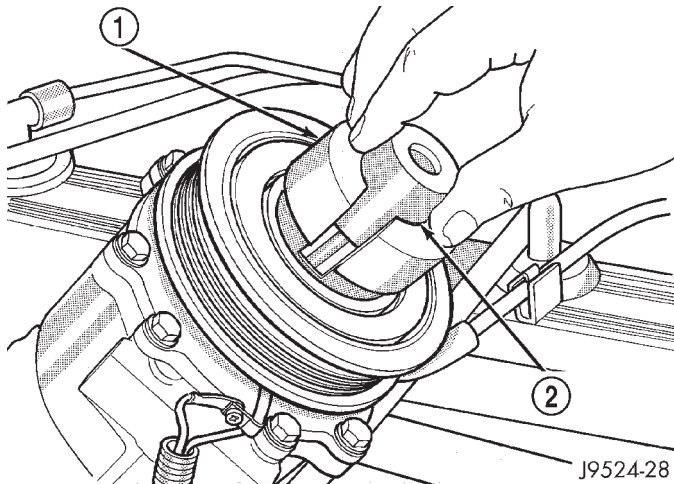
**Fig. 23 Shaft Protector and Puller**

- 1 - PULLER JAW
- 2 - SHAFT PROTECTOR

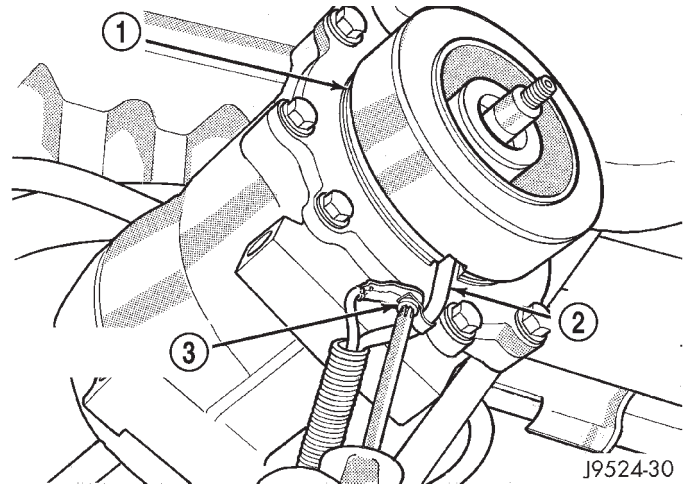
**Fig. 25 Clutch Coil Lead Wire Harness**

- 1 - COIL
- 2 - COIL WIRE
- 3 - RETAINER SCREW

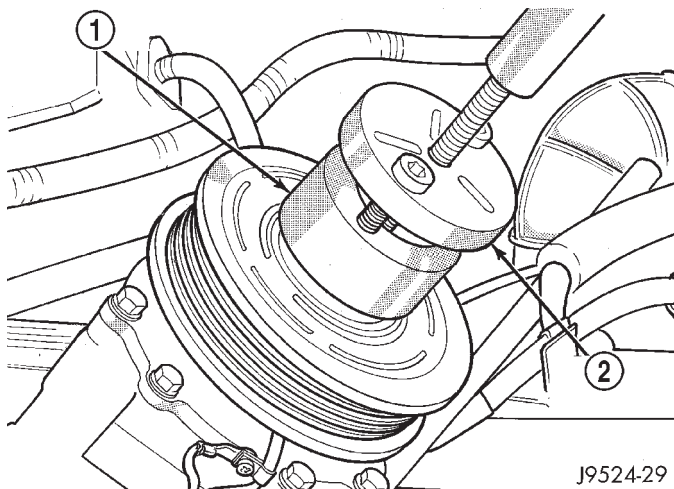
**Fig. 24 Install Puller Plate**

- 1 - PULLER JAW
- 2 - PULLER

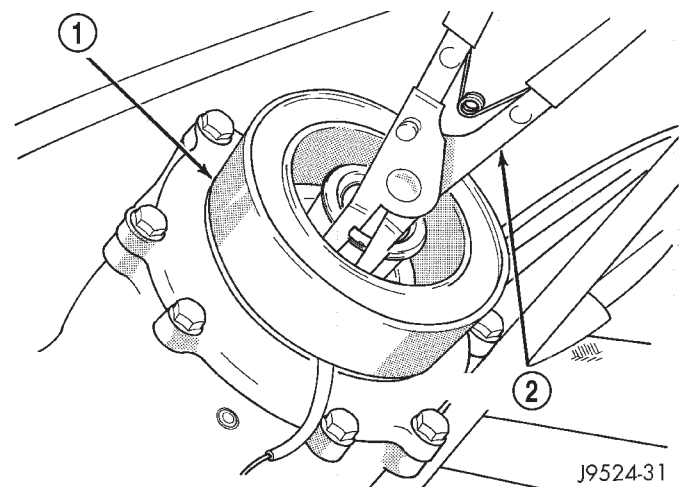
**Fig. 26 Clutch Field Coil Snap Ring Remove**

- 1 - COIL
- 2 - SNAP RING PLIERS

felt from the front cover. If the felt is saturated with oil, the shaft seal is leaking and the compressor must be replaced.

Check the clutch pulley bearing for roughness or excessive leakage of grease. Replace the bearing, if required.

INSTALLATION

- (1) Install the clutch field coil and snap ring.
- (2) Install the clutch coil lead wire harness retaining clip on the compressor front housing and tighten the retaining screw.
- (3) Align the rotor assembly squarely on the front compressor housing hub.
- (4) Install the pulley bearing assembly with the installer (Special Tool C-6871) (Fig. 27). Thread the

installer on the shaft, then turn the nut until the pulley assembly is seated.

- (5) Install the external front snap ring with snap ring pliers. The bevel side of the snap ring must be facing outward. Press the snap ring to make sure it is properly seated in the groove.

CAUTION: If the snap ring is not fully seated in the groove it will vibrate out, resulting in a clutch failure and severe damage to the front housing of the compressor.

- (6) Install the compressor shaft key and the original clutch shims on the compressor shaft.

REMOVAL AND INSTALLATION (Continued)

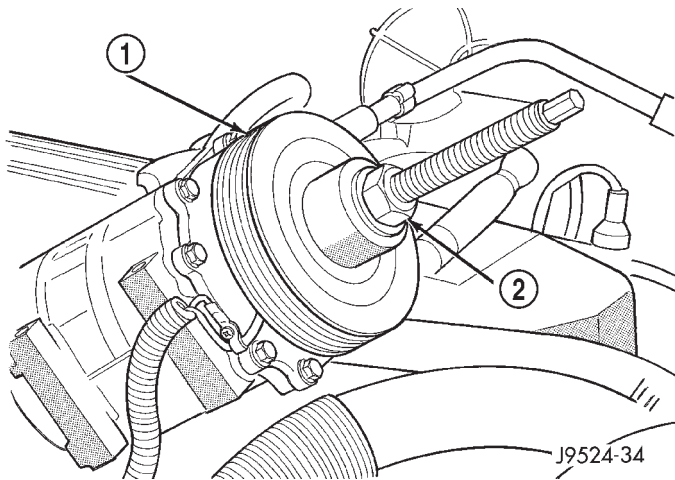

Fig. 27 Clutch Pulley Install

- 1 - PULLEY BEARING ASSEMBLY
- 2 - INSTALLER

(7) Install the clutch plate with the driver (Special Tool C-6463) (Fig. 28). Install the shaft hex nut and tighten to 14.4 N·m (10.5 ft. lbs.).

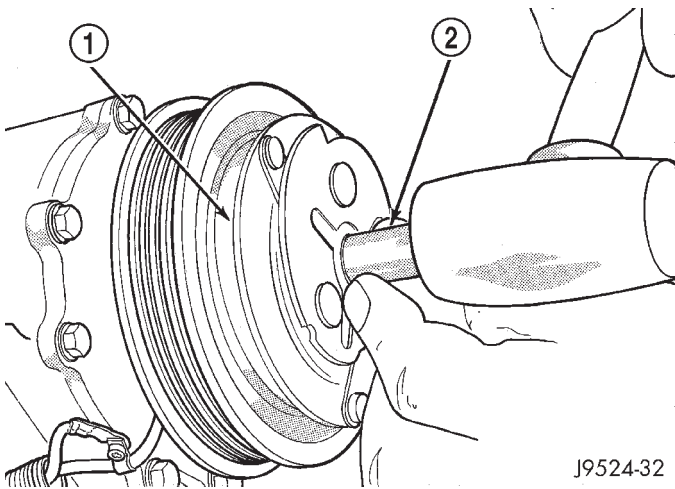

Fig. 28 Clutch Plate Driver

- 1 - CLUTCH PLATE
- 2 - DRIVER

(8) Check the clutch air gap with a feeler gauge (Fig. 29). If the air gap does not meet the specification, add or subtract shims as required. The air gap specification is 0.41 to 0.79 millimeter (0.016 to 0.031 inch). If the air gap is not consistent around the circumference of the clutch, lightly pry up at the minimum variations. Lightly tap down at the points of maximum variation.

NOTE: The air gap is determined by the spacer shims. When installing an original, or a new clutch assembly, try the original shims first. When installing a new clutch onto a compressor that previously

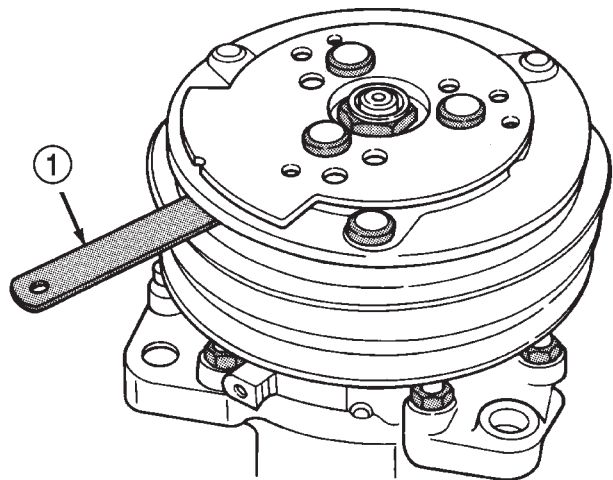

Fig. 29 Check Clutch Air Gap

- 1 - FEELER GAUGE

did not have a clutch, use 1.0, 0.50, and 0.13 millimeter (0.040, 0.020, and 0.005 inch) shims from the clutch hardware package that is provided with the new clutch.

(9) Reverse the remaining removal procedures to complete the installation.

CLUTCH BREAK-IN

After a new compressor clutch has been installed, cycle the compressor clutch approximately twenty times (five seconds on, then five seconds off). During this procedure, set the heater-A/C control to the Recirculation Mode, the blower motor switch in the highest speed position, and the engine speed at 1500 to 2000 rpm. This procedure (burnishing) will seat the opposing friction surfaces and provide a higher compressor clutch torque capability.

COMPRESSOR CLUTCH RELAY

- (1) Disconnect and isolate the battery negative cable.
- (2) Remove the cover from the Power Distribution Center (PDC) (Fig. 30).
- (3) Refer to the label on the PDC for compressor clutch relay identification and location.
- (4) Unplug the compressor clutch relay from the PDC.
- (5) Install the compressor clutch relay by aligning the relay terminals with the cavities in the PDC and pushing the relay firmly into place.
- (6) Install the PDC cover.
- (7) Connect the battery negative cable.
- (8) Test the relay operation.

REMOVAL AND INSTALLATION (Continued)

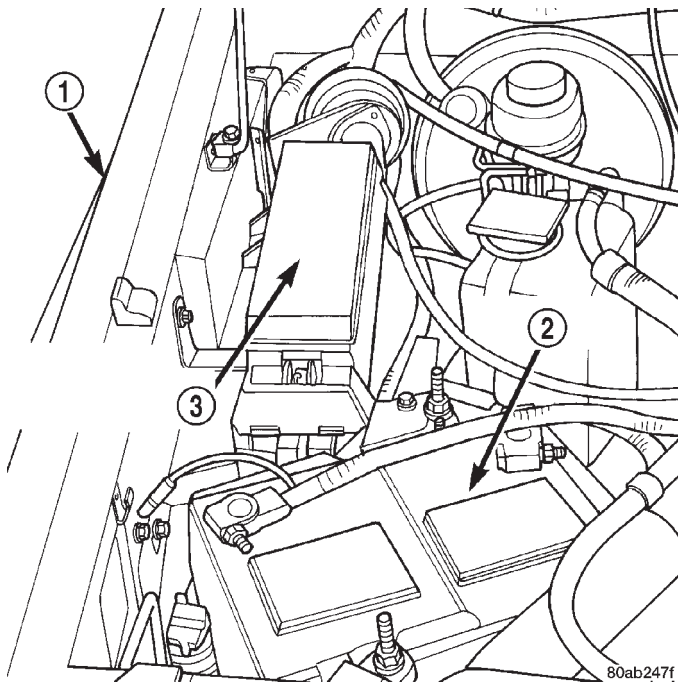
**Fig. 30 Power Distribution Center**

- 1 - RIGHT FENDER
- 2 - BATTERY
- 3 - POWER DISTRIBUTION CENTER

CONDENSER

WARNING: REVIEW THE WARNINGS AND CAUTIONS IN THE FRONT OF THIS GROUP BEFORE PERFORMING THE FOLLOWING OPERATION.

CAUTION: Before removing the condenser, note the location of each of the radiator and condenser air seals. These seals are used to direct air through the condenser and radiator. The air seals must be reinstalled in their proper locations in order for the air conditioning and engine cooling systems to perform as designed.

REMOVAL

- (1) Disconnect and isolate the battery negative cable.
- (2) Recover the refrigerant from the refrigerant system. See Refrigerant Recovery in this group for the procedures.
- (3) Disconnect the discharge line refrigerant line fitting at the condenser inlet. See Refrigerant Line Coupler in this group for the procedures. Install plugs in, or tape over all of the opened refrigerant line fittings.
- (4) Disconnect the liquid line (Left-Hand Drive) or liquid line jumper (Right-Hand Drive) refrigerant

line fitting at the condenser outlet. See Refrigerant Line Coupler in this group for the procedures. Install plugs in, or tape over all of the opened refrigerant line fittings.

(5) Remove the radiator and the condenser from the vehicle as a unit. Refer to Group 7 - Cooling System for the procedures.

(6) Remove the two nuts that secure the condenser studs to the upper brackets of the radiator (Fig. 31).

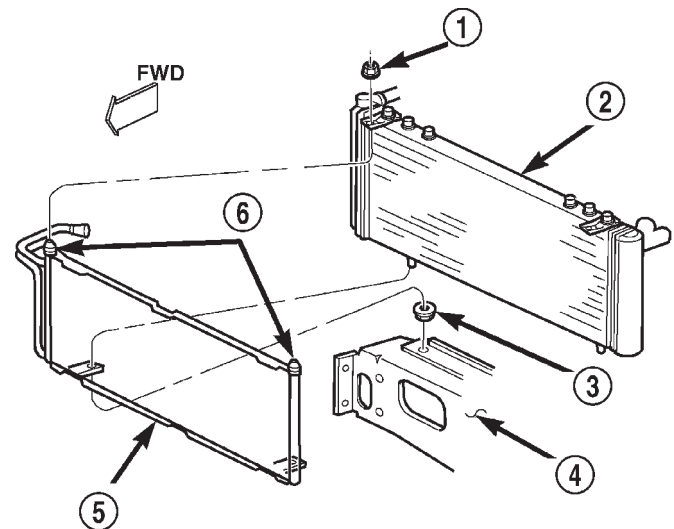
**Fig. 31 Condenser Remove/Install**

- 1 - NUT
- 2 - RADIATOR
- 3 - GROMMET
- 4 - LOWER CROSSMEMBER
- 5 - CONDENSER
- 6 - STUDS

(7) Slide the condenser down from the radiator far enough for the condenser studs to clear the upper radiator bracket holes, and for the lower condenser bracket holes to clear the dowel pins on the bottom of the radiator.

(8) Remove the condenser from the radiator.

INSTALLATION

- (1) Install the holes of the condenser lower brackets over the dowel pins on the bottom of the radiator.
- (2) Slide the condenser upwards until both of the condenser studs are installed through the holes in the radiator upper brackets. Tighten the mounting nuts to 5.3 N·m (47 in. lbs.).
- (3) Reinstall the radiator and condenser unit in the vehicle. Refer to Group 7 - Cooling System for the procedures.
- (4) Remove the tape or plugs from the refrigerant line fittings on the condenser outlet and the liquid line (Left-Hand Drive) or the liquid line jumper (Right-Hand Drive). Install the liquid line or the liq-

80b0d766

REMOVAL AND INSTALLATION (Continued)

uid line jumper to the condenser outlet. See Refrigerant Line Coupler in this group for the procedures.

(5) Remove the tape or plugs from the refrigerant line fittings on the condenser inlet and the discharge line. Connect the discharge line to the condenser inlet. See Refrigerant Line Coupler in this group for the procedures.

(6) Connect the battery negative cable.

(7) Evacuate the refrigerant system. See Refrigerant System Evacuate in this group for the procedures.

(8) Charge the refrigerant system. See Refrigerant System Charge in this group for the procedures.

NOTE: If the condenser is replaced, add 30 milliliters (1 fluid ounce) of refrigerant oil to the refrigerant system. Use only refrigerant oil of the type recommended for the compressor in the vehicle.

DUAL FUNCTION HIGH PRESSURE SWITCH/ HIGH PRESSURE CUT-OFF SWITCH

REMOVAL

(1) Disconnect and isolate the battery negative cable.

(2) Unplug the wire harness connector from the dual function high pressure switch or the high pressure cut-off switch, which is mounted to a fitting on the non-flexible section of the discharge line nearest the compressor.

(3) Unscrew the high pressure switch from the discharge line fitting.

(4) Remove the high pressure switch from the vehicle.

(5) Remove the O-ring seal from the discharge line fitting and discard.

INSTALLATION

(1) Lubricate a new O-ring seal with clean refrigerant oil and install it on the discharge line fitting. Use only the specified O-rings as they are made of a special material for the R-134a system. Use only refrigerant oil of the type recommended for the compressor in the vehicle.

(2) Install and tighten the high pressure switch on the discharge line fitting.

(3) Plug the wire harness connector into the high pressure cut-off switch.

(4) Connect the battery negative cable.

DUCTS AND OUTLETS

WARNING: ON VEHICLES EQUIPPED WITH AIRBAGS, REFER TO GROUP 8M - PASSIVE RESTRAINT SYSTEMS BEFORE ATTEMPTING ANY

STEERING WHEEL, STEERING COLUMN, OR INSTRUMENT PANEL COMPONENT DIAGNOSIS OR SERVICE. FAILURE TO TAKE THE PROPER PRECAUTIONS COULD RESULT IN ACCIDENTAL AIRBAG DEPLOYMENT AND POSSIBLE PERSONAL INJURY.

PANEL OUTLET DUCTS

The panel outlet ducts are integral to the instrument panel assembly. Refer to Instrument Panel Assembly in Group 8E - Instrument Panel Systems for the procedures.

PANEL OUTLET BARRELS

(1) Use a trim stick or another suitable wide flat-bladed tool to gently pry the panel outlet barrel out of the panel outlet housing (Fig. 32). The barrel is retained by a light snap fit.

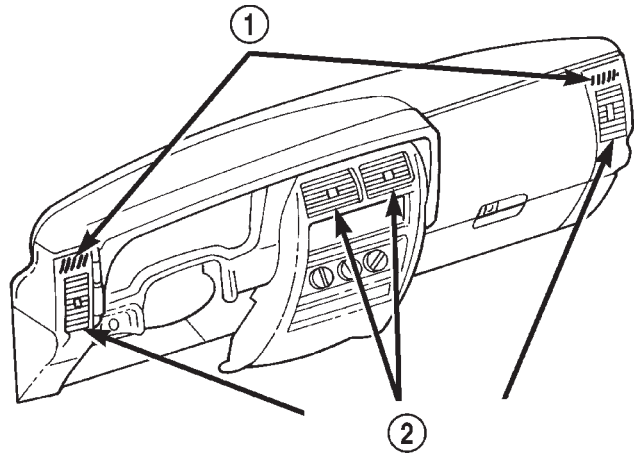

80abd29e

Fig. 32 Panel Outlet Barrels

- 1 - DEMISTER OUTLETS
2 - PANEL OUTLET BARRELS

(2) To install, position the barrel in the panel outlet housing and press firmly until the barrel snaps into place.

DEMISTER OUTLETS

The side window demister outlets are integral to the instrument panel end caps. Refer to Instrument Panel End Cap in Group 8E - Instrument Panel Systems for the procedures.

DEFROST DUCT/DEMISTER ADAPTER

(1) Remove the instrument panel assembly from the vehicle. Refer to Instrument Panel Assembly in Group 8E - Instrument Panel Systems for the procedures.

(2) Disconnect the demister hoses from the defrost duct/demister adapter (Fig. 33).

REMOVAL AND INSTALLATION (Continued)

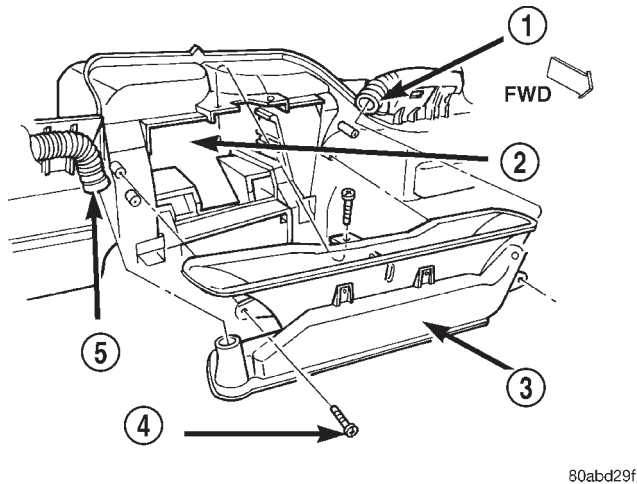
**Fig. 33 Defrost Duct/Demister Adapter**

- 1 - HOSE
- 2 - INSTRUMENT PANEL
- 3 - DEFROST DUCT/DEMISTER ADAPTER
- 4 - SCREW
- 5 - HOSE

(3) Remove the three screws that secure the defrost duct/demister adapter to the instrument panel.

(4) Remove the defrost duct/demister adapter from the instrument panel.

(5) Reverse the removal procedures to install. Tighten the mounting screws to 2.2 N·m (20 in. lbs.).

DEMISTER HOSES

(1) Remove the instrument panel assembly from the vehicle. Refer to Instrument Panel Assembly in Group 8E - Instrument Panel Systems for the procedures.

(2) Disconnect the ends of the demister hose from the demister duct (Fig. 34) and the defrost duct/demister adapter (Fig. 33).

(3) Reverse the removal procedures to install.

DEMISTER DUCTS

(1) Remove the instrument panel assembly from the vehicle. Refer to Instrument Panel Assembly in Group 8E - Instrument Panel Systems for the procedures.

(2) Remove the end cap from the instrument panel. Refer to Instrument Panel End Cap in Group 8E - Instrument Panel Systems for the procedures.

(3) Disconnect the demister hoses from the demister duct (Fig. 34).

(4) Remove the two screws that secure the demister duct to the top of the instrument panel.

(5) Remove the demister duct from the instrument panel.

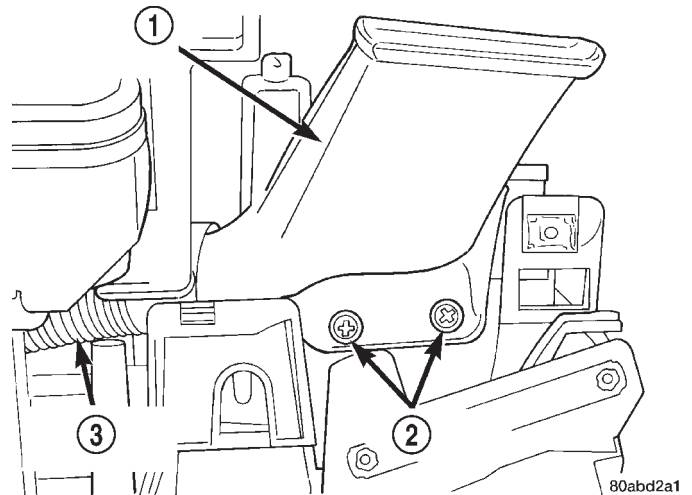
**Fig. 34 Demister Duct Remove/Install**

- 1 - DEMISTER DUCT
- 2 - SCREWS
- 3 - DEMISTER HOSE

(6) Reverse the removal procedures to install. Tighten the mounting screws to 2.2 N·m (20 in. lbs.).

CONSOLE REAR DUCT

(1) Disconnect and isolate the battery negative cable.

(2) Remove the floor console from the floor panel transmission tunnel (Fig. 35). Refer to Group 23 - Body for the procedures.

(3) Lift the rear of the console rear duct out of the console rear mounting bracket on the floor panel transmission tunnel and slide the duct rearward to disengage it from the floor duct and adapter.

(4) Remove the console rear duct from the vehicle.

(5) Reverse the removal procedures to install.

FLOOR DUCT AND ADAPTER

(1) Remove the instrument panel from the vehicle. Refer to Instrument Panel Assembly in Group 8E - Instrument Panel Systems for the procedures.

(2) Remove the heater-A/C housing from the vehicle. See Heater-A/C Housing in this group for the procedures.

(3) Remove the three screws that secure the floor duct and adapter to the heater-A/C housing (Fig. 35).

(4) Remove the floor duct and adapter from the heater-A/C housing.

(5) Reverse the removal procedures to install. Tighten the mounting screws to 2.2 N·m (20 in. lbs.).

REMOVAL AND INSTALLATION (Continued)

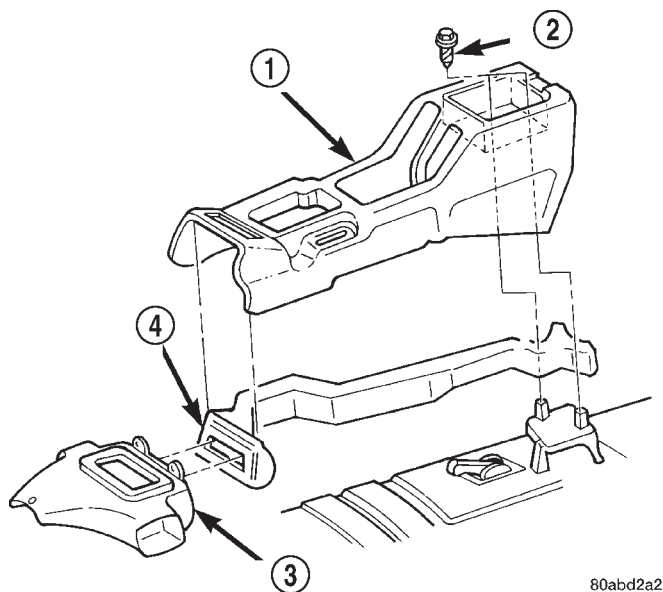

80abd2a2

Fig. 35 Floor Duct and Console Rear Duct Remove/Install

- 1 - FLOOR CONSOLE
- 2 - SCREW
- 3 - FLOOR DUCT AND ADAPTER
- 4 - CONSOLE REAR DUCT

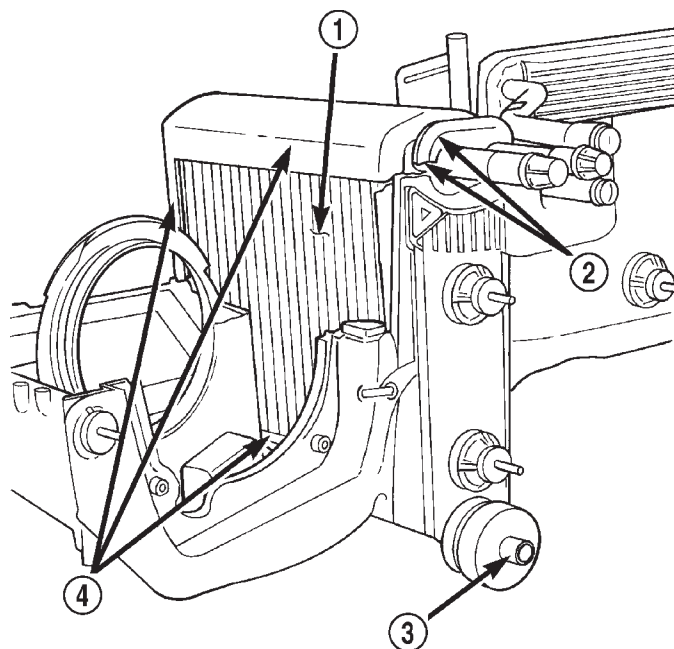

80abd29a

Fig. 36 Evaporator Coil Remove/Install

- 1 - EVAPORATOR COIL
- 2 - TUBE SEAL
- 3 - CONDENSATE DRAIN TUBE
- 4 - FOAM INSULATOR WRAP

EVAPORATOR COIL

WARNING: ON VEHICLES EQUIPPED WITH AIR-BAGS, REFER TO GROUP 8M - PASSIVE RESTRAINT SYSTEMS BEFORE ATTEMPTING ANY STEERING WHEEL, STEERING COLUMN, OR INSTRUMENT PANEL COMPONENT DIAGNOSIS OR SERVICE. FAILURE TO TAKE THE PROPER PRECAUTIONS COULD RESULT IN ACCIDENTAL AIR-BAG DEPLOYMENT AND POSSIBLE PERSONAL INJURY.

(1) Remove and disassemble the heater-A/C housing. See Heater-A/C Housing in this group for the procedures.

(2) Lift the evaporator coil unit out of the lower half of the heater-A/C housing (Fig. 36).

(3) Reverse the removal procedures to install. Be certain that the evaporator foam insulator wrap and rubber tube seal are reinstalled.

NOTE: If the evaporator is replaced, add 60 milliliters (2 fluid ounces) of refrigerant oil to the refrigerant system. Use only refrigerant oil of the type recommended for the compressor in the vehicle.

FIXED ORIFICE TUBE

The fixed orifice tube is located in the liquid line (Left-Hand Drive) or the liquid line jumper (Right-

Hand Drive) near the condenser. The orifice has filter screens on the inlet and outlet ends of the tube body. If the fixed orifice tube is faulty or plugged, the liquid line unit or liquid line jumper unit must be replaced. See Liquid Line in this group for the service procedures.

HEATER-A/C CONTROL

WARNING: ON VEHICLES EQUIPPED WITH AIR-BAGS, REFER TO GROUP 8M - PASSIVE RESTRAINT SYSTEMS BEFORE ATTEMPTING ANY STEERING WHEEL, STEERING COLUMN, OR INSTRUMENT PANEL COMPONENT DIAGNOSIS OR SERVICE. FAILURE TO TAKE THE PROPER PRECAUTIONS COULD RESULT IN ACCIDENTAL AIR-BAG DEPLOYMENT AND POSSIBLE PERSONAL INJURY.

REMOVAL

(1) Disconnect and isolate the battery negative cable.

(2) Roll down the glove box from the instrument panel. Refer to Glove Box in Group 8E - Instrument Panel Systems for the procedures.

(3) Reach through the instrument panel glove box opening to access and unplug the two halves of the heater-A/C vacuum harness connector.

REMOVAL AND INSTALLATION (Continued)

(4) Remove the center bezel from the instrument panel. Refer to Instrument Panel Center Bezel in Group 8E - Instrument Panel Systems for the procedures.

(5) Release the vacuum harness push-in retainer from the instrument panel directly beneath the heater-A/C control.

(6) Remove the four screws that secure the heater-A/C control to the instrument panel (Fig. 37).

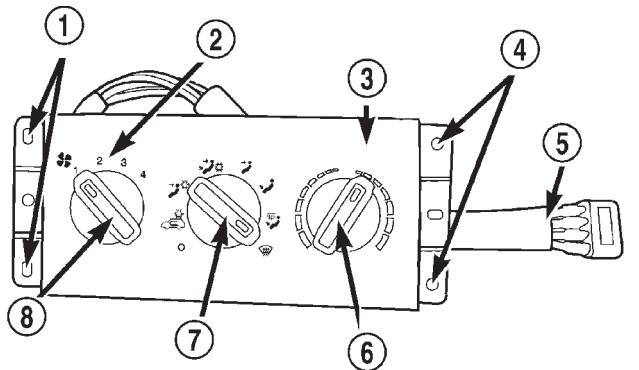

80ba777C

Fig. 37 Heater-A/C Control Remove/Install

- 1 - MOUNTING HOLES
- 2 - CONTROL HEAD
- 3 - HEATER-A/C CONTROL HEAD
- 4 - MOUNTING HOLES
- 5 - VACUUM HARNESS
- 6 - TEMPERATURE SELECT CONTROL
- 7 - MODE SELECT CONTROL
- 8 - BLOWER SPEED CONTROL

(7) Pull the heater-A/C control assembly away from the instrument panel far enough to access the connections on the back of the control.

(8) Unplug the wire harness connectors from the back of the heater-A/C control (Fig. 38).

(9) Reach through the instrument panel glove box opening to guide the heater-A/C control half of the vacuum harness around any obstacles while pulling the heater-A/C control out from the front of the instrument panel.

INSTALLATION

(1) Plug the wire harness connectors into the back of the heater-A/C control.

(2) Route the vacuum harness through the instrument panel opening and reinstall the vacuum harness push-in retainer.

(3) Reach through the instrument panel glove box opening to reconnect the two halves of the heater-A/C vacuum harness connector.

(4) Roll the glove box back up into the instrument panel. Refer to Glove Box in Group 8E - Instrument Panel Systems for the procedures.

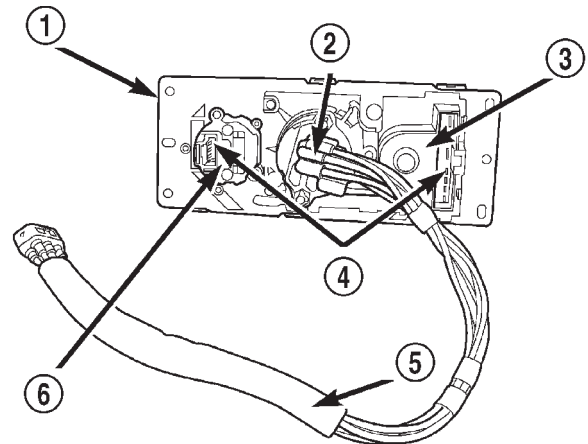

80ba7771

Fig. 38 Heater-A/C Control Connections

- 1 - HEATER-A/C CONTROL HEAD
- 2 - MODE SELECT CONTROL
- 3 - BLOWER SPEED CONTROL
- 4 - ELECTRICAL CONNECTORS
- 5 - VACUUM HARNESS
- 6 - TEMPERATURE SELECT CONTROL

(5) Position the heater-A/C control in the instrument panel and secure it with four screws. Tighten the screws to 2.2 N·m (20 in. lbs.).

(6) Reinstall the center bezel onto the instrument panel. Refer to Instrument Panel Center Bezel in Group 8E - Instrument Panel Systems for the procedures.

(7) Connect the battery negative cable.

HEATER-A/C HOUSING

The heater-A/C housing assembly must be removed from the vehicle and the two halves of the housing separated for service access of the heater core, evaporator coil, blend-air door, and each of the various mode control doors.

WARNING: ON VEHICLES EQUIPPED WITH AIR-BAGS, REFER TO GROUP 8M - PASSIVE RESTRAINT SYSTEMS BEFORE ATTEMPTING ANY STEERING WHEEL, STEERING COLUMN, OR INSTRUMENT PANEL COMPONENT DIAGNOSIS OR SERVICE. FAILURE TO TAKE THE PROPER PRECAUTIONS COULD RESULT IN ACCIDENTAL AIR-BAG DEPLOYMENT AND POSSIBLE PERSONAL INJURY.

REMOVAL

(1) Disconnect and isolate the battery negative cable.

(2) Remove the instrument panel from the vehicle. Refer to Instrument Panel Assembly in Group 8E - Instrument Panel Systems for the procedures.

REMOVAL AND INSTALLATION (Continued)

(3) If the vehicle is not equipped with air conditioning, go to Step 6. If the vehicle is equipped with air conditioning, recover the refrigerant from the refrigerant system. See Refrigerant Recovery in this group for the procedures.

(4) Disconnect the liquid line refrigerant line fitting from the evaporator inlet tube. See Refrigerant Line Coupler in this group for the procedures. Install plugs in, or tape over all of the opened refrigerant line fittings.

(5) Disconnect the accumulator inlet tube refrigerant line fitting from the evaporator outlet tube. See Refrigerant Line Coupler in this group for the procedures. Install plugs in, or tape over all of the opened refrigerant line fittings.

(6) Drain the engine cooling system. Refer to Group 7 - Cooling System for the procedures.

(7) Disconnect the heater hoses from the heater core tubes. Refer to Group 7 - Cooling System for the procedures. Install plugs in, or tape over the opened heater core tubes.

(8) Unplug the heater-A/C system vacuum supply line connector from the tee fitting near the heater core tubes.

(9) Unplug the heater-A/C unit wire harness connector, which is fastened to the heater-A/C housing next to the blower motor relay (Fig. 39).

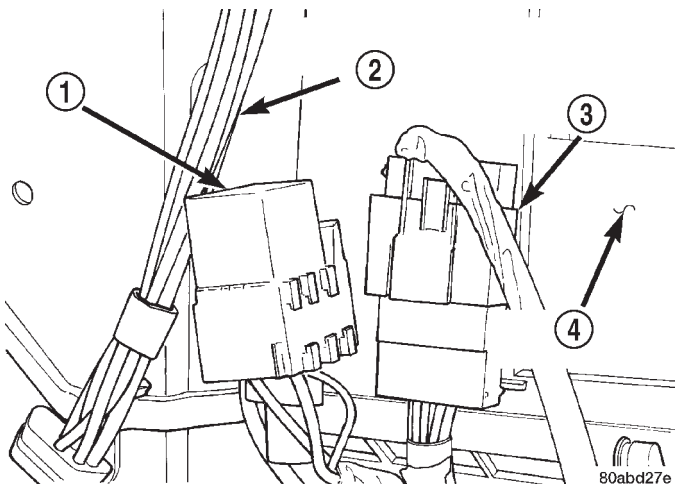

Fig. 39 Heater-A/C Unit Connector

- 1 - BLOWER MOTOR RELAY
- 2 - VACUUM HARNESS
- 3 - HEATER-A/C WIRE HARNESS CONNECTOR
- 4 - HEATER-A/C HOUSING

(10) Remove the five nuts from the heater-A/C housing mounting studs on the engine compartment side of the dash panel (Fig. 40). Remove or reposition the evaporation canister for additional access, if required.

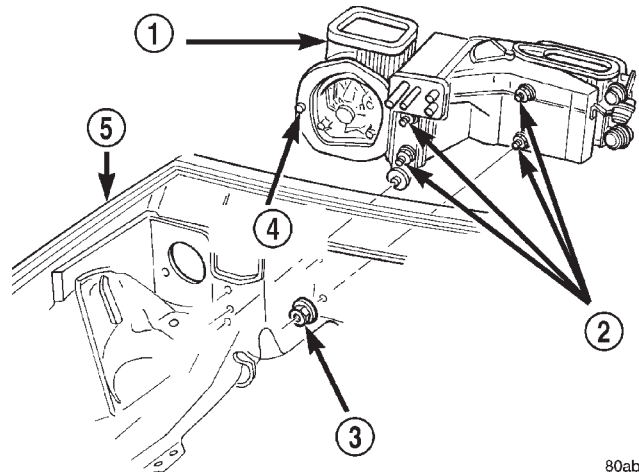

Fig. 40 Heater-A/C Housing Remove/Install

- 1 - HEATER-A/C HOUSING
- 2 - STUD
- 3 - NUT
- 4 - STUD
- 5 - RIGHT FRONT FENDER

(11) Pull the heater-A/C housing rearward far enough for the mounting studs and the evaporator condensate drain tube to clear the dash panel holes.

(12) Remove the heater-A/C housing from the vehicle.

DISASSEMBLY

(1) Remove the heater-A/C housing from the vehicle and place it on a work bench.

(2) Unplug the vacuum harness connectors from the floor door actuator and, if the unit is so equipped, the recirculation air door actuator.

(3) Disengage the vacuum harness from any routing clips located on the lower half of the heater-A/C housing.

(4) Disengage the heater-A/C wire harness connector and the blower motor relay wire harness connector push-in retainers from their mounting holes on the heater-A/C housing.

(5) Remove the blower motor and blower wheel unit from the heater-A/C housing. See Blower Motor in this group for the procedures.

(6) Carefully remove the foam seal from the flange around the blower motor opening in the heater-A/C housing. If the seal is deformed or damaged, it must be replaced.

(7) Pull the vacuum supply line and connector through the foam seal on the heater core and evaporator coil tube mounting flange of the heater-A/C housing (Fig. 41).

(8) If the unit is equipped with air conditioning, remove the screw that secures the clamp to the evaporator coil tubes and remove the clamp.

REMOVAL AND INSTALLATION (Continued)

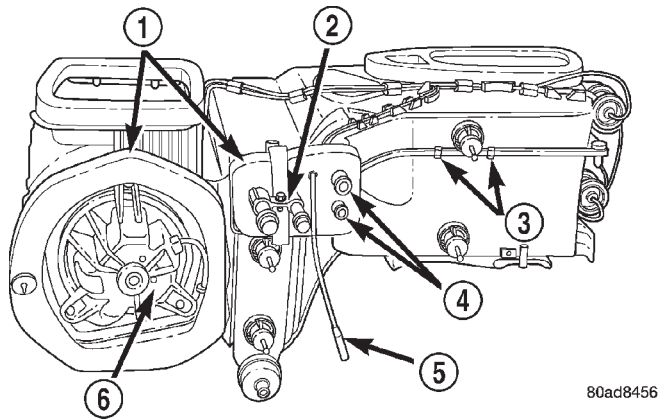
**Fig. 41 Heater-A/C Housing Disassembly**

- 1 - SEALS
- 2 - EVAPORATOR TUBE CLAMP
- 3 - CLIPS
- 4 - HEATER CORE TUBES
- 5 - VACUUM SUPPLY LINE
- 6 - BLOWER MOTOR

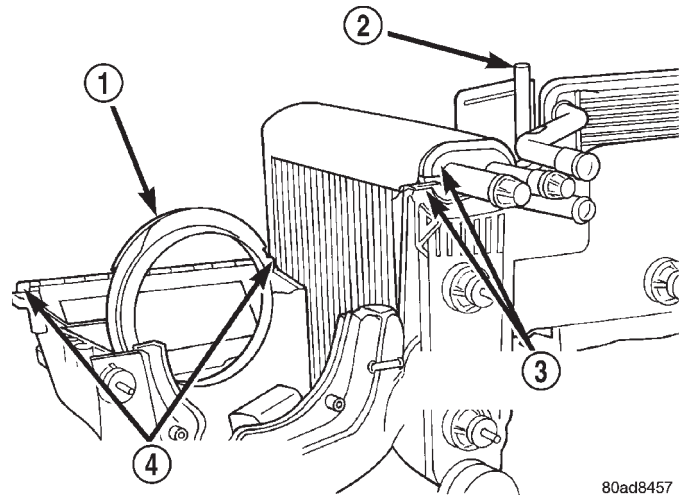
**Fig. 42 Heater-A/C Housing Assembly**

- 1 - BLOWER MOTOR VENTURI RING
- 2 - BLEND-AIR DOOR PIVOT
- 3 - EVAPORATOR COIL TUBE RUBBER SEAL
- 4 - RECIRCULATION AIR DOOR PIVOTS

(9) Carefully remove the foam seal from the heater core and evaporator coil tube mounting flange of the heater-A/C housing. If the seal is deformed or damaged, it must be replaced.

(10) Use a screwdriver to pry off the two snap clips that help secure the upper and lower heater-A/C housing halves to each other.

(11) Remove the 14 screws that secure the upper and lower heater-A/C housing halves to each other.

(12) Carefully separate the upper heater-A/C housing half from the lower half.

ASSEMBLY

(1) Assemble the upper heater-A/C housing half to the lower half. During assembly, be certain of the following:

(a) That each of the mode door pivot shaft ends is properly engaged in its pivot hole (Fig. 42).

(b) That the blower motor venturi ring is properly indexed and installed.

(c) If the unit is equipped with air conditioning, that the evaporator coil tube rubber seal is properly positioned in the grooves in both the upper and lower heater-A/C housing halves.

(2) Install the 14 screws and two snap clips that secure the upper and lower heater-A/C housing halves to each other. Tighten the screws to 2.2 N·m (20 in. lbs.).

(3) Install the blower motor and wheel unit in the heater-A/C housing. See Blower Motor in this group for the procedures.

(4) Install the foam seals on the flanges around the blower motor opening and the heater core and evaporator coil tube mounting flange of the heater-A/C housing.

(5) Insert the vacuum supply line and connector through the foam seal on the heater core and evaporator coil tube mounting flange of the heater-A/C housing.

(6) If the unit is equipped with air conditioning, reinstall the evaporator coil tube clamp. Tighten the mounting screw to 2.2 N·m (20 in. lbs.).

(7) Engage the heater-A/C wire harness connector and blower motor relay wire harness connector push-in retainers with their mounting holes in the heater-A/C housing.

(8) Engage the vacuum harness to the routing clips and plug in the vacuum harness connector at the floor door actuator and, if the unit is so equipped, at the recirculation air door actuator.

(9) Install the heater-A/C housing in the vehicle.

INSTALLATION

(1) Position the heater-A/C housing to the dash panel. Be certain that the evaporator condensate drain tube and the housing mounting studs are inserted into their correct mounting holes.

(2) Install and tighten the five nuts onto the heater-A/C housing mounting studs on the engine compartment side of the dash panel. Tighten the nuts to 6.2 N·m (55 in. lbs.).

(3) If the evaporation canister was repositioned during the removal procedure, reinstall it to its proper position.

(4) Connect the heater-A/C system vacuum supply line connector to the tee fitting near the heater core tubes.

(5) Unplug or remove the tape from the heater core tubes. Connect the heater hoses to the heater

REMOVAL AND INSTALLATION (Continued)

core tubes and fill the engine cooling system. Refer to Group 7 - Cooling System for the procedures.

(6) If the vehicle is not equipped with air conditioning, go to Step 10. If the vehicle is equipped with air conditioning, unplug or remove the tape from the accumulator inlet tube and the evaporator outlet tube fittings. Connect the accumulator inlet tube coupler to the evaporator outlet tube. See Refrigerant Line Coupler in this group for the procedures.

(7) Unplug or remove the tape from the liquid line and the evaporator inlet tube fittings. Connect the liquid line coupler to the evaporator inlet tube. See Refrigerant Line Coupler in this group for the procedures.

(8) Evacuate the refrigerant system. See Refrigerant System Evacuate in this group for the procedures.

(9) Charge the refrigerant system. See Refrigerant System Charge in this group for the procedures.

(10) Install the instrument panel in the vehicle. Refer to Instrument Panel Assembly in Group 8E - Instrument Panel Systems for the procedures.

(11) Connect the battery negative cable.

(12) Start the engine and check for proper operation of the heating and air conditioning systems.

HEATER-A/C HOUSING DOOR

WARNING: ON VEHICLES EQUIPPED WITH AIR-BAGS, REFER TO GROUP 8M - PASSIVE RESTRAINT SYSTEMS BEFORE ATTEMPTING ANY STEERING WHEEL, STEERING COLUMN, OR INSTRUMENT PANEL COMPONENT DIAGNOSIS OR SERVICE. FAILURE TO TAKE THE PROPER PRECAUTIONS COULD RESULT IN ACCIDENTAL AIR-BAG DEPLOYMENT AND POSSIBLE PERSONAL INJURY.

BLEND-AIR DOOR

(1) Remove and disassemble the heater-A/C housing. See Heater-A/C Housing in this group for the procedures.

(2) Lift the blend-air door pivot shaft out of the pivot hole in the bottom of the lower half of the heater-A/C housing (Fig. 43).

(3) Reverse the removal procedures to install.

PANEL/DEMIST DOOR AND LEVER

(1) Remove and disassemble the heater-A/C housing. See Heater-A/C Housing in this group for the procedures.

(2) Remove the defrost and panel/demist door vacuum actuators from the heater-A/C housing. See Mode Door Vacuum Actuator in this group for the procedures.

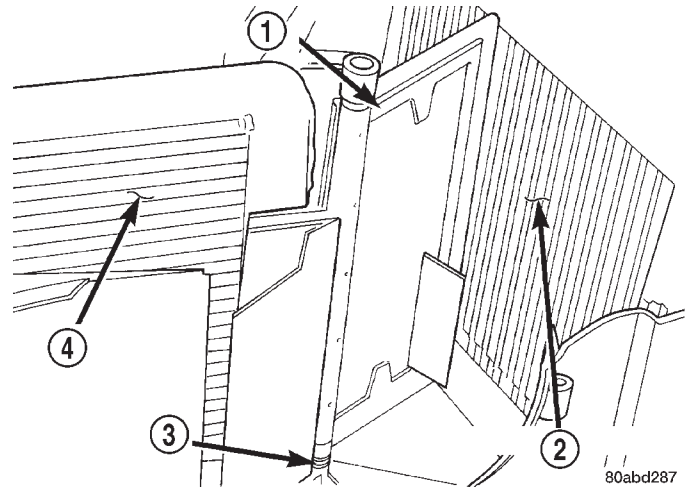

Fig. 43 Blend-Air Door

- 1 - BLEND-AIR DOOR
- 2 - EVAPORATOR COIL
- 3 - PIVOT HOLE
- 4 - HEATER CORE

(3) Insert a screwdriver into the latch hole (Fig. 44) of the panel/demist door pivot shaft to release the latch of the panel/demist door lever, and pull the lever out of the pivot shaft from the outside of the upper half of the heater-A/C housing.

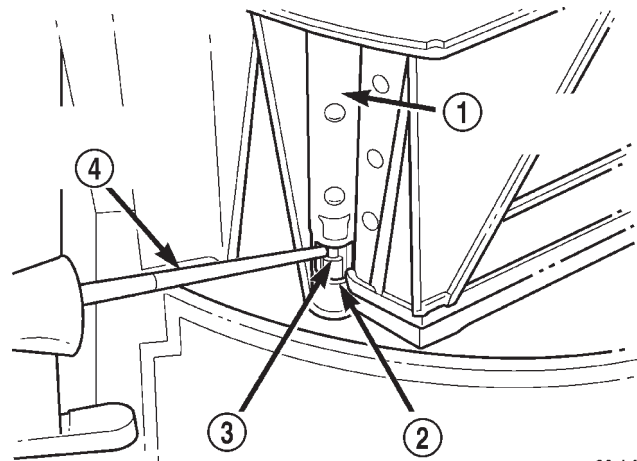

Fig. 44 Mode Door Lever Remove/Install - Typical

- 1 - DOOR PIVOT SHAFT
- 2 - LATCH HOLE
- 3 - CRANK ARM LATCH
- 4 - FLAT BLADE PRY TOOL

(4) Reach inside the upper half of the heater-A/C housing and carefully flex the panel/defrost door (Fig. 45) enough so that the door pivot clears the pivot hole in the housing.

(5) Remove the panel/demist door from the heater-A/C housing.

(6) Reverse the removal procedures to install.

REMOVAL AND INSTALLATION (Continued)

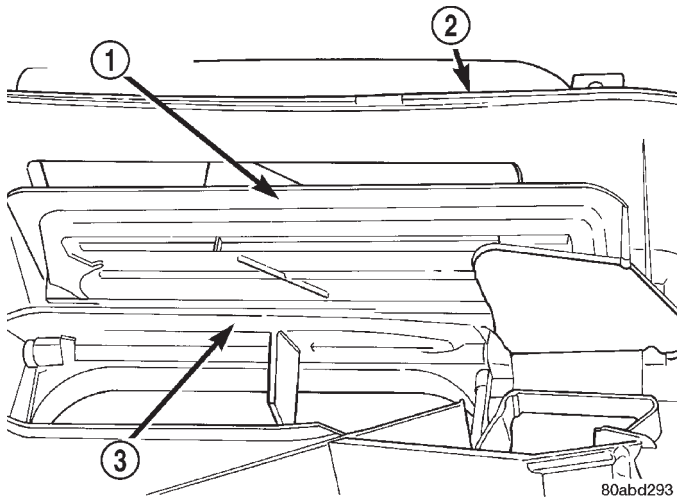
**Fig. 45 Panel/Demist and Defrost Doors**

- 1 - PANEL/DEMIST DOOR
- 2 - UPPER HEATER-A/C HOUSING
- 3 - DEFROST DOOR

DEFROST DOOR AND LEVER

(1) Remove and disassemble the heater-A/C housing. See Heater-A/C Housing in this group for the procedures.

(2) Remove the panel/demist door and lever from the upper heater-A/C housing. See Panel/Demist Door and Lever in this group for the procedures.

(3) Insert a screwdriver into the latch hole (Fig. 44) of the defrost door pivot shaft to release the latch of the defrost door lever, and pull the lever out of the pivot shaft from the outside of the upper half of the heater-A/C housing.

(4) Reach inside the upper half of the heater-A/C housing and carefully flex the defrost door (Fig. 45) enough so that the door pivot clears the pivot hole in the housing.

(5) Remove the defrost door from the heater-A/C housing.

(6) Reverse the removal procedures to install.

FLOOR DOOR AND LEVER

(1) Remove and disassemble the heater-A/C housing. See Heater-A/C Housing in this group for the procedures.

(2) Remove the floor door vacuum actuator from the lower heater-A/C housing. See Mode Door Vacuum Actuator in this group for the procedures.

(3) Insert a screwdriver into the latch hole (Fig. 44) of the floor door pivot shaft to release the latch of the floor door lever, and pull the lever out of the pivot shaft from the outside of the lower half of the heater-A/C housing.

(4) Reach inside the lower half of the heater-A/C housing and carefully flex the floor door (Fig. 46)

enough so that the door pivot clears the pivot hole in the housing.

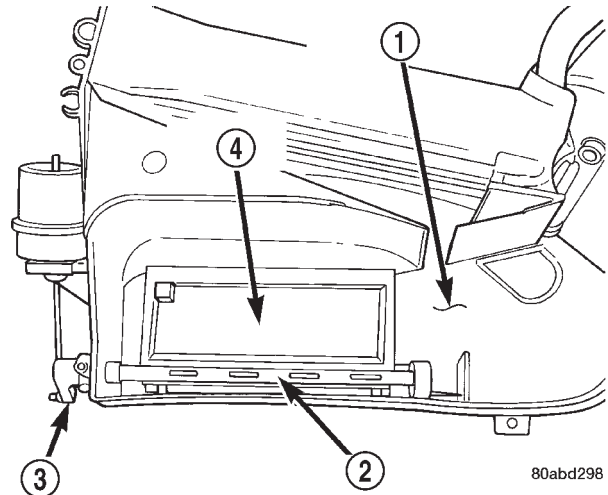
**Fig. 46 Floor Door**

- 1 - LOWER HEATER-A/C HOUSING
- 2 - PIVOT SHAFT
- 3 - CRANK ARM
- 4 - FLOOR DOOR

(5) Remove the floor door from the heater-A/C housing.

(6) Reverse the removal procedures to install.

RECIRCULATION AIR DOOR

A recirculation air door and vacuum actuator are used only on models with the optional air conditioning system.

(1) Remove and disassemble the heater-A/C housing. See Heater-A/C Housing in this group for the procedures.

(2) Remove the recirculation air door vacuum actuator from the lower heater-A/C housing. See Mode Door Vacuum Actuator in this group for the procedures.

(3) Reach inside the lower half of the heater-A/C housing and lift the bottom edge of the recirculation air door upwards (Fig. 47).

(4) Guide the recirculation air door lever through the air intake grille of the heater-A/C housing while removing the door from the housing.

(5) Reverse the removal procedures to install.

REMOVAL AND INSTALLATION (Continued)

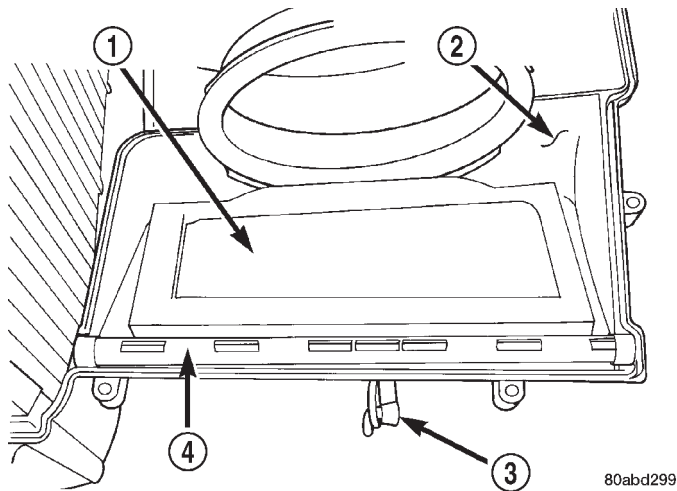
**Fig. 47 Recirculation Air Door**

- 1 - RECIRCULATION AIR DOOR
- 2 - LOWER HEATER-A/C HOUSING
- 3 - LEVER
- 4 - PIVOT SHAFT

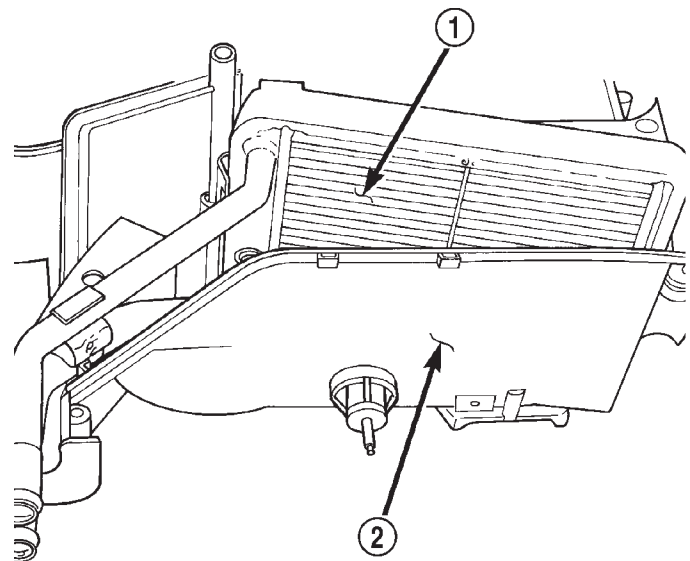
**Fig. 48 Heater Core Remove/Install**

- 1 - HEATER CORE
- 2 - LOWER HEATER-A/C HOUSING

HEATER CORE

WARNING: ON VEHICLES EQUIPPED WITH AIR-BAGS, REFER TO GROUP 8M - PASSIVE RESTRAINT SYSTEMS BEFORE ATTEMPTING ANY STEERING WHEEL, STEERING COLUMN, OR INSTRUMENT PANEL COMPONENT DIAGNOSIS OR SERVICE. FAILURE TO TAKE THE PROPER PRECAUTIONS COULD RESULT IN ACCIDENTAL AIR-BAG DEPLOYMENT AND POSSIBLE PERSONAL INJURY.

(1) Remove and disassemble the heater-A/C housing. See Heater-A/C Housing in this group for the procedures.

(2) Lift the heater core out of the lower half of the heater-A/C housing (Fig. 48).

(3) Reverse the removal procedures to install. Be certain that the heater core foam insulator is reinstalled.

LIQUID LINE

Any kinks or sharp bends in the refrigerant plumbing will reduce the capacity of the entire air conditioning system. Kinks and sharp bends reduce the flow of refrigerant in the system. A good rule for the flexible hose refrigerant lines is to keep the radius of all bends at least ten times the diameter of the hose. In addition, the flexible hose refrigerant lines should be routed so they are at least 80 millimeters (3 inches) from the exhaust manifold.

High pressures are produced in the refrigerant system when the air conditioning compressor is operating. Extreme care must be exercised to make sure

that each of the refrigerant system connections is pressure-tight and leak free. It is a good practice to inspect all flexible hose refrigerant lines at least once a year to make sure they are in good condition and properly routed.

WARNING: REVIEW THE WARNINGS AND CAUTIONS IN THE FRONT OF THIS GROUP BEFORE PERFORMING THE FOLLOWING OPERATION.

REMOVAL

(1) Disconnect and isolate the battery negative cable.

(2) Recover the refrigerant from the refrigerant system. See Refrigerant Recovery in this group for the procedures.

(3) Disconnect the liquid line refrigerant line couplers at the evaporator inlet and the condenser outlet (Fig. 49). See Refrigerant Line Coupler in this group for the procedures. Install plugs in, or tape over all of the opened refrigerant line fittings.

(4) Remove the liquid line from the vehicle.

INSTALLATION

(1) Remove the tape or plugs from the refrigerant line fittings on the liquid line, the evaporator inlet and the condenser outlet. Connect the liquid line to the evaporator inlet and condenser outlet refrigerant line couplers. See Refrigerant Line Coupler in this group for the procedures.

(2) Connect the battery negative cable.

REMOVAL AND INSTALLATION (Continued)

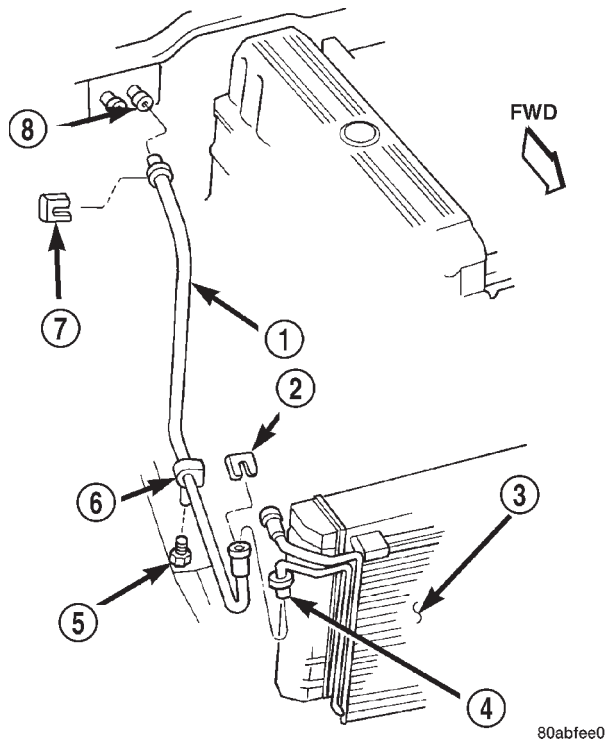
**Fig. 49 Liquid Line Remove/Install**

- 1 - LIQUID LINE WITH ORIFICE TUBE
- 2 - CLIP
- 3 - CONDENSER
- 4 - OUTLET TUBE
- 5 - STUD
- 6 - CLIP
- 7 - CLIP
- 8 - EVAPORATOR INLET

(3) Evacuate the refrigerant system. See Refrigerant System Evacuate in this group for the procedures.

(4) Charge the refrigerant system. See Refrigerant System Charge in this group for the procedures.

LOW PRESSURE CYCLING CLUTCH SWITCH**REMOVAL**

(1) Disconnect and isolate the battery negative cable.

(2) Unplug the wire harness connector from the low pressure cycling clutch switch on the top of the accumulator (Fig. 50).

(3) Unscrew the low pressure cycling clutch switch from the fitting on the top of the accumulator.

(4) Remove the O-ring seal from the accumulator fitting and discard.

INSTALLATION

(1) Lubricate a new O-ring seal with clean refrigerant oil and install it on the accumulator fitting. Use only the specified O-rings as they are made of a

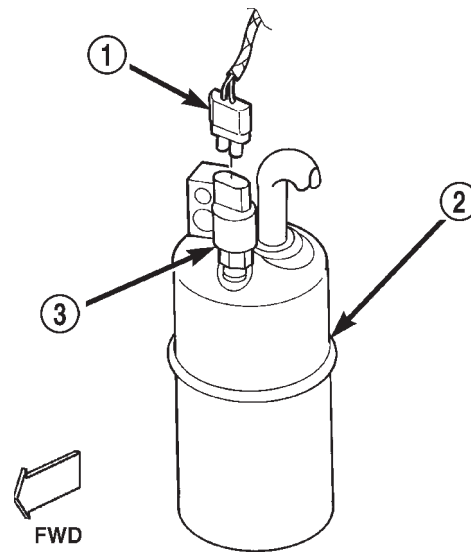

80abd2a4

Fig. 50 Low Pressure Cycling Clutch Switch Remove/Install - Typical

- 1 - WIRE HARNESS CONNECTOR
- 2 - ACCUMULATOR
- 3 - LOW PRESSURE CYCLING CLUTCH SWITCH

special material for the R-134a system. Use only refrigerant oil of the type recommended for the compressor in the vehicle.

(2) Install and tighten the low pressure cycling clutch switch on the accumulator fitting. The switch should be hand-tightened onto the accumulator fitting.

(3) Plug the wire harness connector into the low pressure cycling clutch switch.

(4) Connect the battery negative cable.

KICK COVER

WARNING: ON VEHICLES EQUIPPED WITH AIRBAGS, REFER TO GROUP 8M - PASSIVE RESTRAINT SYSTEMS BEFORE ATTEMPTING ANY STEERING WHEEL, STEERING COLUMN, OR INSTRUMENT PANEL COMPONENT DIAGNOSIS OR SERVICE. FAILURE TO TAKE THE PROPER PRECAUTIONS COULD RESULT IN ACCIDENTAL AIRBAG DEPLOYMENT AND POSSIBLE PERSONAL INJURY.

REMOVAL

(1) Disconnect and isolate the battery negative cable.

(2) Loosen the two screws that secure the upper half of the kick cover to the heater-A/C housing

REMOVAL AND INSTALLATION (Continued)

under the passenger side end of the instrument panel (Fig. 51).

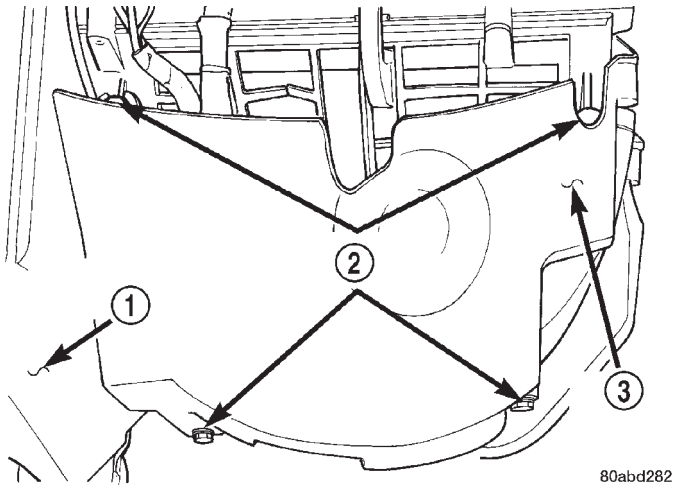

Fig. 51 Kick Cover Remove/Install

- 1 - HEATER-A/C HOUSING
- 2 - MOUNTING SCREWS
- 3 - KICK COVER

(3) Remove the two screws that secure the lower half of the kick cover to the heater-A/C housing.

(4) Pull the kick cover down towards the floor panel to disengage the slotted upper mounting tabs from under the two loosened heater-A/C housing screws.

(5) Remove the kick cover from the heater-A/C housing.

INSTALLATION

(1) Position the slotted upper kick cover mounting tabs under the heads of the two loosened heater-A/C housing screws. Tighten the screws to 2.2 N·m (20 in. lbs.).

(2) Install the two screws that secure the lower kick cover to the heater-A/C housing. Tighten the screws to 2.2 N·m (20 in. lbs.).

(3) Connect the battery negative cable.

MODE DOOR VACUUM ACTUATOR

WARNING: ON VEHICLES EQUIPPED WITH AIR-BAGS, REFER TO GROUP 8M - PASSIVE RESTRAINT SYSTEMS BEFORE ATTEMPTING ANY STEERING WHEEL, STEERING COLUMN, OR INSTRUMENT PANEL COMPONENT DIAGNOSIS OR SERVICE. FAILURE TO TAKE THE PROPER PRECAUTIONS COULD RESULT IN ACCIDENTAL AIR-BAG DEPLOYMENT AND POSSIBLE PERSONAL INJURY.

DEFROST DOOR ACTUATOR

(1) Disconnect and isolate the battery negative cable.

(2) Remove the instrument panel assembly from the vehicle. Refer to Instrument Panel Assembly in Group 8E - Instrument Panel Systems for the procedures.

(3) Unplug the two vacuum harness connectors from the defrost door actuator (Fig. 52).

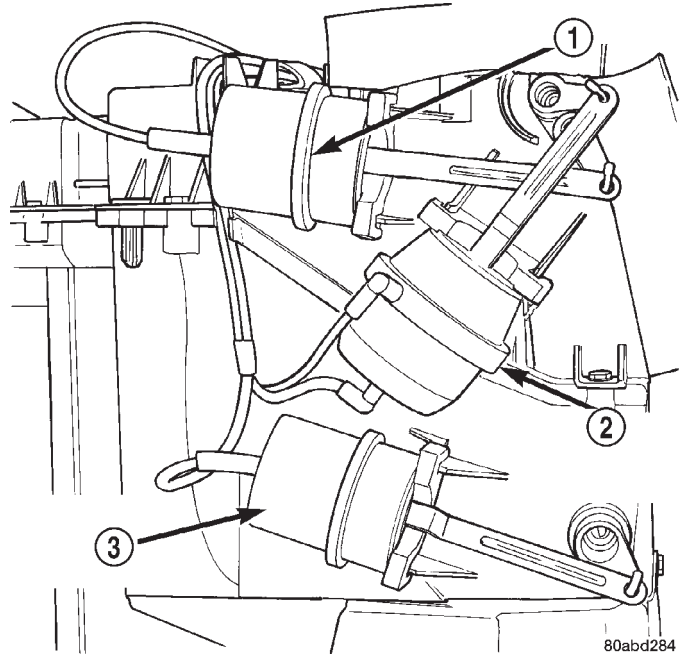

Fig. 52 Defrost, Floor, and Panel/Demist Door Vacuum Actuators

- 1 - PANEL/DEMIST DOOR ACTUATOR
- 2 - DEFROST DOOR ACTUATOR
- 3 - FLOOR DOOR ACTUATOR

(4) Insert a trim stick or another suitable wide flat-bladed tool into the latch hole on the heater-A/C housing actuator mount (Fig. 53). Gently pry the actuator latch while pulling firmly outwards on the actuator to remove the actuator from the mount.

(5) Rotate and tilt the vacuum actuator as required to disengage the hole on the end of the actuator link from the hooked pin on the end of the defrost door lever.

(6) Remove the defrost door vacuum actuator from the vehicle.

(7) Reverse the removal procedures to install.

FLOOR DOOR ACTUATOR

(1) Disconnect and isolate the battery negative cable.

(2) Remove the instrument panel assembly from the vehicle. Refer to Instrument Panel Assembly in

REMOVAL AND INSTALLATION (Continued)

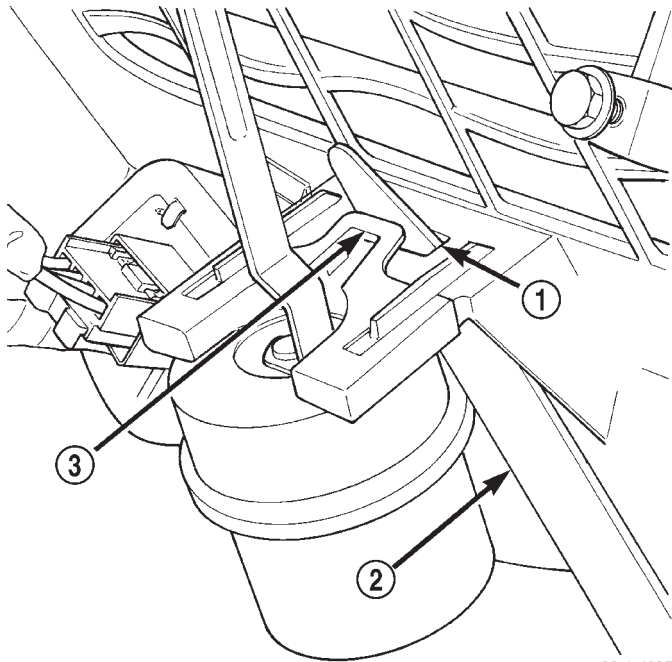

80abd285

Fig. 53 Vacuum Actuator Remove/Install - Typical

- 1 - ACTUATOR MOUNT LATCH HOLE
- 2 - TRIM STICK
- 3 - ACTUATOR LATCH

Group 8E - Instrument Panel Systems for the procedures.

(3) Unplug the vacuum harness connector from the floor door actuator (Fig. 52).

(4) Insert a trim stick or another suitable wide flat-bladed tool into the latch hole on the heater-A/C housing actuator mount (Fig. 53). Gently pry the actuator latch while pulling firmly outwards on the actuator to remove the actuator from the mount.

(5) Rotate and tilt the vacuum actuator as required to disengage the hole on the end of the actuator link from the hooked pin on the end of the floor door lever.

(6) Remove the floor door vacuum actuator from the vehicle.

(7) Reverse the removal procedures to install.

PANEL/DEMIST DOOR ACTUATOR

(1) Remove the defrost door actuator from the heater-A/C housing. See Defrost Door Actuator in this group for the procedures.

(2) Unplug the vacuum harness connector from the panel/demist door actuator (Fig. 52).

(3) Insert a trim stick or another suitable wide flat-bladed tool into the latch hole on the heater-A/C housing actuator mount (Fig. 53). Gently pry the actuator latch while pulling firmly outwards on the actuator to remove the actuator from the mount.

(4) Rotate and tilt the vacuum actuator as required to disengage the hole on the end of the actuator link from the hooked pin on the end of the panel/demist door lever.

(5) Remove the panel/demist door vacuum actuator from the vehicle.

(6) Reverse the removal procedures to install.

RECIRCULATION AIR DOOR ACTUATOR

A recirculation air door and vacuum actuator are used only on models with the optional air conditioning system.

(1) Disconnect and isolate the battery negative cable.

(2) Remove the kick cover from the heater-A/C housing. See Kick Cover in this group for the procedures.

(3) Unplug the vacuum harness connector from the recirculation air door actuator (Fig. 54).

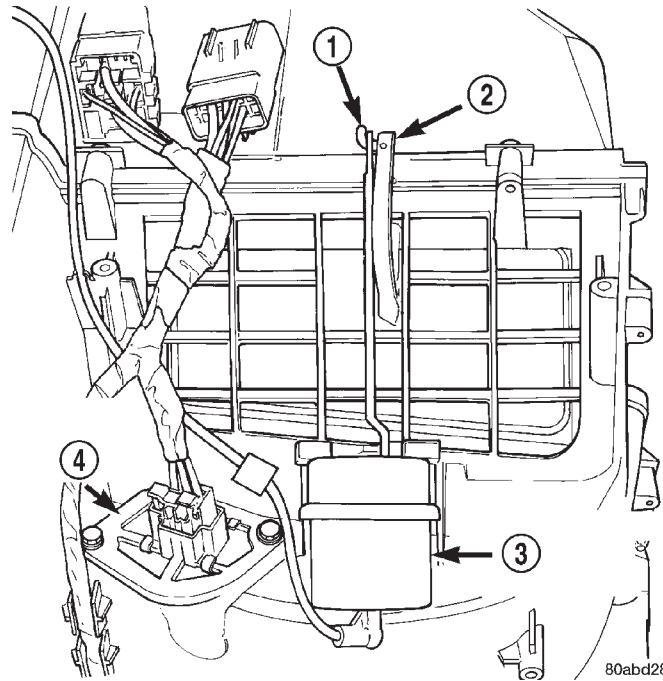

80abd286

Fig. 54 Recirculation Air Door Vacuum Actuator Remove/Install

- 1 - HOOK
- 2 - LEVER
- 3 - RECIRCULATION AIR DOOR ACTUATOR
- 4 - BLOWER MOTOR RESISTOR

(4) Insert a trim stick or another suitable wide flat-bladed tool into the latch hole on the heater-A/C housing actuator mount (Fig. 53). Gently pry the actuator latch while pulling firmly outwards on the actuator to remove the actuator from the mount.

(5) Rotate and tilt the vacuum actuator as required to disengage the hole on the end of the

REMOVAL AND INSTALLATION (Continued)

actuator link from the hooked pin on the end of the recirculation air door lever.

(6) Remove the recirculation air door vacuum actuator from the vehicle.

(7) Reverse the removal procedures to install.

REFRIGERANT LINE COUPLER

WARNING: REVIEW THE WARNINGS AND CAUTIONS IN THE GENERAL INFORMATION SECTION NEAR THE FRONT OF THIS GROUP BEFORE PERFORMING THE FOLLOWING OPERATION.

REMOVAL

(1) Recover the refrigerant from the refrigerant system. See Refrigerant Recovery in the Service Procedures section of this group.

(2) Remove the secondary clip from the spring-lock coupler.

(3) Fit the proper size A/C line disconnect tool (Special Tool Kit 7193) over the spring-lock coupler cage (Fig. 55).

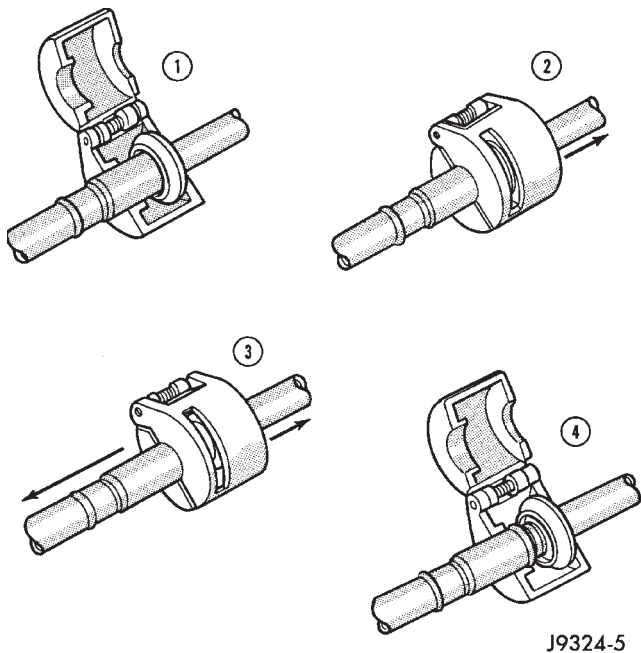

Fig. 55 Refrigerant Line Spring-Lock Coupler Disconnect

(4) Close the two halves of the A/C line disconnect tool around the spring-lock coupler.

(5) Push the A/C line disconnect tool into the open side of the coupler cage to expand the garter spring. Once the garter spring is expanded and while still pushing the disconnect tool into the open side of the coupler cage, pull on the refrigerant line attached to the female half of the coupler fitting until the flange on the female fitting is separated from the garter

spring and cage on the male fitting within the disconnect tool.

NOTE: The garter spring may not release if the A/C line disconnect tool is cocked while pushing it into the coupler cage opening.

(6) Open and remove the A/C line disconnect tool from the disconnected spring-lock coupler.

(7) Complete the separation of the two halves of the coupler fitting.

INSTALLATION

(1) Check to ensure that the garter spring is located within the cage of the male coupler fitting, and that the garter spring is not damaged.

(a) If the garter spring is missing, install a new spring by pushing it into the coupler cage opening.

(b) If the garter spring is damaged, remove it from the coupler cage with a small wire hook (DO NOT use a screwdriver) and install a new garter spring.

(2) Clean any dirt or foreign material from both halves of the coupler fitting.

(3) Install new O-rings on the male half of the coupler fitting.

CAUTION: Use only the specified O-rings as they are made of a special material for the R-134a system. The use of any other O-rings may allow the connection to leak intermittently during vehicle operation.

(4) Lubricate the male fitting and O-rings, and the inside of the female fitting with clean R-134a refrigerant oil. Use only refrigerant oil of the type recommended for the compressor in the vehicle.

(5) Fit the female half of the coupler fitting over the male half of the fitting.

(6) Push together firmly on the two halves of the coupler fitting until the garter spring in the cage on the male half of the fitting snaps over the flanged end on the female half of the fitting.

(7) Ensure that the spring-lock coupler is fully engaged by trying to separate the two coupler halves. This is done by pulling the refrigerant lines on either side of the coupler away from each other.

(8) Reinstall the secondary clip over the spring-lock coupler cage.

SUCTION AND DISCHARGE LINE

Any kinks or sharp bends in the refrigerant plumbing will reduce the capacity of the entire air conditioning system. Kinks and sharp bends reduce the flow of refrigerant in the system. A good rule for the flexible hose refrigerant lines is to keep the radius of all bends at least ten times the diameter of the hose.

REMOVAL AND INSTALLATION (Continued)

In addition, the flexible hose refrigerant lines should be routed so they are at least 80 millimeters (3 inches) from the exhaust manifold.

High pressures are produced in the refrigerant system when the air conditioning compressor is operating. Extreme care must be exercised to make sure that each of the refrigerant system connections is pressure-tight and leak free. It is a good practice to inspect all flexible hose refrigerant lines at least once a year to make sure they are in good condition and properly routed.

WARNING: REVIEW THE WARNINGS AND CAUTIONS IN THE FRONT OF THIS GROUP BEFORE PERFORMING THE FOLLOWING OPERATION.

REMOVAL

(1) Disconnect and isolate the battery negative cable.

(2) Recover the refrigerant from the refrigerant system. See Refrigerant Recovery in this group for the procedures.

(3) Unplug the wire harness connector from the high pressure cut-off switch.

(4) Disconnect the discharge line refrigerant line fitting from the condenser inlet tube (Fig. 56). See Refrigerant Line Coupler in this group for the procedures. Install plugs in, or tape over all of the opened refrigerant line fittings.

(5) Remove the nut that secures the suction line block fitting to the accumulator outlet. Install plugs in, or tape over all of the opened refrigerant line fittings.

(6) Remove the screw that secures the suction and discharge line manifold to the compressor. Install plugs in, or tape over all of the opened refrigerant line fittings.

(7) Remove the suction and discharge line assembly from the vehicle.

INSTALLATION

(1) Remove the tape or plugs from the suction and discharge line manifold and the compressor. Install the suction and discharge line manifold to the compressor. Tighten the mounting screw to 28 N·m (250 in. lbs.).

(2) Remove the tape or plugs from the suction line and the accumulator outlet block fittings. Install the suction line to the accumulator outlet and tighten the mounting nut to 9 N·m (80 in. lbs.).

(3) Remove the tape or plugs from the refrigerant line fittings on the discharge line and the condenser inlet tube. Connect the discharge line refrigerant line coupler to the condenser inlet tube. See Refrigerant Line Coupler in this group for the procedures.

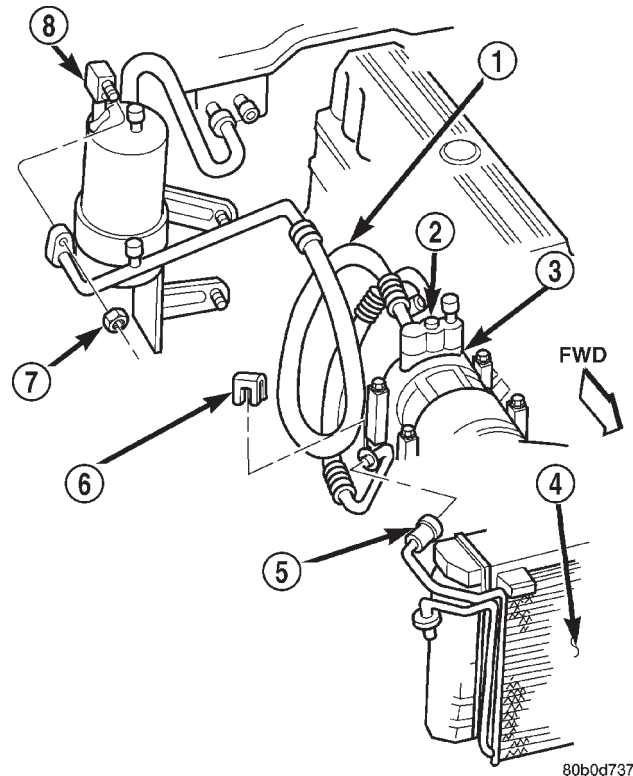

Fig. 56 Suction and Discharge Line

- 1 - SUCTION AND DISCHARGE LINE
- 2 - SCREW
- 3 - COMPRESSOR
- 4 - CONDENSER
- 5 - INLET
- 6 - CLIP
- 7 - HEX NUT
- 8 - ACCUMULATOR

(4) Plug in the wire harness connector to the high pressure cut-off switch.

(5) Connect the battery negative cable.

(6) Evacuate the refrigerant system. See Refrigerant System Evacuate in this group for the procedures.

(7) Charge the refrigerant system. See Refrigerant System Charge in this group for the procedures.

VACUUM CHECK VALVE

(1) Unplug the heater-A/C vacuum supply line connector at the vacuum check valve (Fig. 57).

(2) Note the orientation of the check valve in the vacuum supply line for correct reinstallation.

(3) Unplug the vacuum check valve from the vacuum supply line fittings.

(4) Reverse the removal procedures to install.

REMOVAL AND INSTALLATION (Continued)

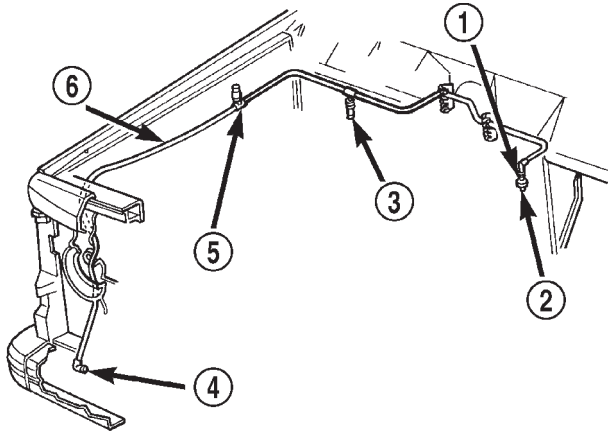

80abd2a3

Fig. 57 Vacuum Supply

- 1 - VACUUM CHECK VALVE
- 2 - TO ENGINE INTAKE MANIFOLD
- 3 - TO HEATER-A/C CONTROLS
- 4 - TO VACUUM RESERVOIR
- 5 - TO SPEED CONTROL SERVO
- 6 - VACUUM SUPPLY LINE

VACUUM RESERVOIR

(1) Remove the passenger side bumper end cap from the front bumper. Refer to Group 23 - Body for the procedures.

(2) Unplug the vacuum supply line connector from the vacuum reservoir (Fig. 58).

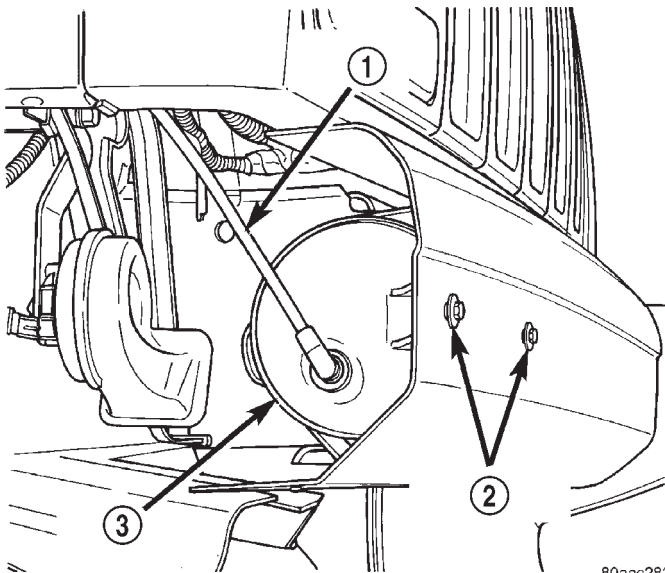

80aac282

Fig. 58 Vacuum Reservoir Remove/Install

- 1 - VACUUM LINE
- 2 - RESERVOIR SCREWS
- 3 - VACUUM RESERVOIR

(3) Remove the two screws that secure the vacuum reservoir to the front bumper.

(4) Remove the vacuum reservoir from behind the front bumper.

(5) Reverse the removal procedures to install. Tighten the mounting screws to 2.2 N-m (20 in. lbs.).

SPECIFICATIONS

A/C APPLICATION TABLE

Item	Description	Notes
Vehicle	XJ Cherokee/ Laredo	
System	R134a w/orifice tube	
Compressor	Sanden SD7H15	SP-20 PAG oil
Freeze-up Control	Low Pressure cycling cutout switch	accumulator mounted
Low psi Control	opens < 25 psi - resets > 43 psi	
High psi Control	switch - opens > 450-490 psi - resets < 270-330 psi	discharge line
Control Head	manual type	
Mode Door	vacuum	
Blend-Air Door	electric	
Fresh/Recirc door	vacuum	
Blower Motor	hardwired to control head	resistor block
Cooling Fan	viscous for cooling, single speed electric for A/C	
Clutch		
Control	relay	PCM
Draw	2 - 3.7 amps @ 12V	± 0.5V @ 70° F
Gap	0.016" - 0.031"	
DRB III®		
Reads	TPS, RPM, A/C switch test	
Actuators	clutch and fan relay	

