

EMISSION CONTROL SYSTEMS

TABLE OF CONTENTS

	page		page
ON-BOARD DIAGNOSTICS	1	EVAPORATIVE EMISSION CONTROLS	23

ON-BOARD DIAGNOSTICS

TABLE OF CONTENTS

	page		page
DESCRIPTION AND OPERATION		TASK MANAGER	16
EMISSION SYSTEM.....	1	MONITORED SYSTEMS.....	19
MALFUNCTION INDICATOR LAMP (MIL)	2	TRIP DEFINITION	21
STATE DISPLAY TEST MODE	2	COMPONENT MONITORS.....	21
CIRCUIT ACTUATION TEST MODE	2	NON-MONITORED CIRCUITS	22
DIAGNOSTIC TROUBLE CODES.....	2	HIGH AND LOW LIMITS.....	22
DIAGNOSTIC TROUBLE CODE		LOAD VALUE.....	22
DESCRIPTIONS	3		

DESCRIPTION AND OPERATION

EMISSION SYSTEM

OPERATION

The Powertrain Control Module (PCM) monitors many different circuits in the fuel injection, ignition, emission and engine systems. If the PCM senses a problem with a monitored circuit often enough to indicate an actual problem, it stores a Diagnostic Trouble Code (DTC) in the PCM's memory. If the code applies to a non-emissions related component or system, and the problem is repaired or ceases to exist, the PCM cancels the code after 40 warm-up cycles. Diagnostic trouble codes that affect vehicle emissions illuminate the Malfunction Indicator Lamp (MIL). The MIL is displayed as an engine icon on the instrument panel. Refer to Malfunction Indicator Lamp (MIL) in this section.

Certain criteria must be met before the PCM stores a DTC in memory. The criteria may be a specific range of engine RPM, engine temperature, and/or input voltage to the PCM.

The PCM might not store a DTC for a monitored circuit even though a malfunction has occurred. This may happen because one of the DTC criteria for the circuit has not been met. **For example**, assume the

diagnostic trouble code criteria requires the PCM to monitor the circuit only when the engine operates between 750 and 2000 RPM. Suppose the sensor's output circuit shorts to ground when engine operates above 2400 RPM (resulting in 0 volt input to the PCM). Because the condition happens at an engine speed above the maximum threshold (2000 rpm), the PCM will not store a DTC.

There are several operating conditions for which the PCM monitors and sets DTC's. Refer to Monitored Systems, Components, and Non-Monitored Circuits in this section.

Technicians must retrieve stored DTC's by connecting the DRB scan tool (or an equivalent scan tool) to the 16-way data link connector (Fig. 1).

NOTE: Various diagnostic procedures may actually cause a diagnostic monitor to set a DTC. For instance, pulling a spark plug wire to perform a spark test may set the misfire code. When a repair is completed and verified, connect the DRB scan tool to the 16-way data link connector to erase all DTC's and extinguish the MIL.



DESCRIPTION AND OPERATION (Continued)

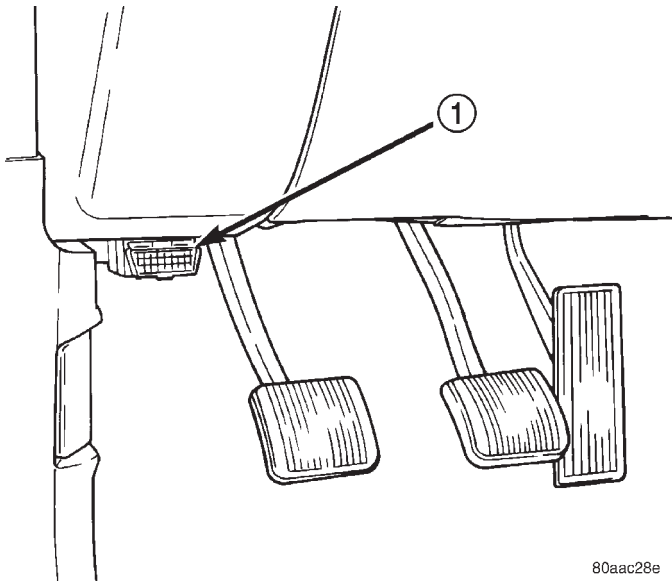

Fig. 1 Data Link (Diagnostic) Connector Location

1 - 16-WAY DATA LINK CONNECTOR

MALFUNCTION INDICATOR LAMP (MIL)

DESCRIPTION

The Malfunction Indicator Lamp (MIL) is located on the instrument panel. It is displayed as an engine icon (graphic).

OPERATION

As a functional test, the MIL illuminates at key-on before engine cranking. Whenever the Powertrain Control Module (PCM) sets a Diagnostic Trouble Code (DTC) that affects vehicle emissions, it illuminates the MIL. If a problem is detected, the PCM sends a message to the instrument cluster to illuminate the lamp. The PCM illuminates the MIL only for DTC's that affect vehicle emissions. There are some monitors that may take two consecutive trips, with a detected fault, before the MIL is illuminated. The MIL stays on continuously when the PCM has entered a Limp-In mode or identified a failed emission component. Refer to the Diagnostic Trouble Code charts in this group for emission related codes.

Also, the MIL either flashes or illuminates continuously when the PCM detects active engine misfire. Refer to Misfire Monitoring in this section.

Additionally, the PCM may reset (turn off) the MIL when one of the following occur:

- PCM does not detect the malfunction for 3 consecutive trips (except misfire and Fuel system Monitors).
- PCM does not detect a malfunction while performing three successive engine misfire or fuel system tests. The PCM performs these tests while the engine is operating within ± 375 RPM of and within

10 % of the load of the operating condition at which the malfunction was first detected.

STATE DISPLAY TEST MODE

OPERATION

The switch inputs to the Powertrain Control Module (PCM) have two recognized states; HIGH and LOW. For this reason, the PCM cannot recognize the difference between a selected switch position versus an open circuit, a short circuit, or a defective switch. If the State Display screen shows the change from HIGH to LOW or LOW to HIGH, assume the entire switch circuit to the PCM functions properly. Connect the DRB scan tool to the data link connector and access the state display screen. Then access either State Display Inputs and Outputs or State Display Sensors.

CIRCUIT ACTUATION TEST MODE

OPERATION

The Circuit Actuation Test Mode checks for proper operation of output circuits or devices the Powertrain Control Module (PCM) may not internally recognize. The PCM attempts to activate these outputs and allow an observer to verify proper operation. Most of the tests provide an audible or visual indication of device operation (click of relay contacts, fuel spray, etc.). Except for intermittent conditions, if a device functions properly during testing, assume the device, its associated wiring, and driver circuit work correctly. Connect the DRB scan tool to the data link connector and access the Actuators screen.

DIAGNOSTIC TROUBLE CODES

OPERATION

A Diagnostic Trouble Code (DTC) indicates that the Powertrain Control Module (PCM) has recognized an abnormal condition in the system.

DTC's are the results of a system or circuit failure, but do not directly identify the failed component or components.

Technicians must retrieve stored DTC's by connecting the DRB III scan tool (or an equivalent scan tool) to the 16-way data link connector. This connector is located on the lower edge of the instrument panel near the steering column.

OBTAINING DTC's

WARNING: APPLY PARKING BRAKE AND/OR BLOCK WHEELS BEFORE PERFORMING ANY TEST ON AN OPERATING ENGINE.

DESCRIPTION AND OPERATION (Continued)

- (1) Connect the DRB scan tool to data link (diagnostic) connector.
- (2) Turn the ignition switch on, access Read Fault Screen. Record all the DTC's shown on the DRB scan tool.

- (3) To erase DTC's, use the Erase Trouble Code data screen on the DRB scan tool.

NOTE: For a list of DTC's, refer to the following charts.

DIAGNOSTIC TROUBLE CODE DESCRIPTIONS

(M) Malfunction Indicator Lamp (MIL) illuminated during engine operation if this DTC was recorded (depending if required by CARB and/or EPA). MIL is displayed as an engine icon on instrument panel.		
(G) Generator lamp illuminated		
Generic Scan Tool P-Code	DRB Scan Tool Display	Brief Description of DTC
P0030 (M)	1/1 O2 Sensor Heater Relay Circuit	Problem detected in oxygen sensor heater relay circuit.
P0036 (M)	1/2 O2 Sensor Heater Relay Circuit	Problem detected in oxygen sensor heater relay circuit.
P0106	Barometric Pressure Out of Range	MAP sensor input voltage out of an acceptable range detected during reading of barometric pressure at key-on.
P0107 (M)	Map Sensor Voltage Too Low	MAP sensor input below minimum acceptable voltage.
P0108 (M)	Map Sensor Voltage Too High	MAP sensor input above maximum acceptable voltage.
P0112 (M)	Intake Air Temp Sensor Voltage Low	Intake air (charge) temperature sensor input below the minimum acceptable voltage.
P0113 (M)	Intake Air Temp Sensor Voltage High	Intake air (charge) temperature sensor input above the maximum acceptable voltage.
P0116		A rationatilty error has been detected in the coolant temp sensor.
P0117 (M)	ECT Sensor Voltage Too Low	Engine coolant temperature sensor input below the minimum acceptable voltage.
P0118 (M)	ECT Sensor Voltage Too High	Engine coolant temperature sensor input above the maximum acceptable voltage.
P0121 (M)	TPS Voltage Does Not Agree With MAP	TPS signal does not correlate to MAP sensor signal.
P0121 (M)	Accelerator Position Sensor (APPS) Signal Voltage Too Low	APPS voltage input below the minimum acceptable voltage.
P0122 (M)	Throttle Position Sensor Voltage Low	Throttle position sensor input below the acceptable voltage range.
P0122 (M)	Accelerator Position Sensor (APPS) Signal Voltage Too Low	APPS voltage input below the minimum acceptable voltage.
P0123 (M)	Throttle Position Sensor Voltage High	Throttle position sensor input above the maximum acceptable voltage.
P0123 (M)	Accelerator Position Sensor (APPS) Signal Voltage Too High	APPS voltage input above the maximum acceptable voltage.
P0125 (M)	Closed Loop Temp Not Reached	Time to enter Closed Loop Operation (Fuel Control) is excessive.
P0125 (M)	Engine is Cold Too Long	Engine does not reach operating temperature.
P0130 (M)	1/1 O2 Sensor Heater Circuit Malfunction	Oxygen sensor heater element malfunction.

DESCRIPTION AND OPERATION (Continued)

(M) Malfunction Indicator Lamp (MIL) illuminated during engine operation if this DTC was recorded (depending if required by CARB and/or EPA). MIL is displayed as an engine icon on instrument panel.		
P0131 (M)	1/1 O2 Sensor Shorted To Ground	Oxygen sensor input voltage maintained below normal operating range.
P0132 (M)	1/1 O2 Sensor Shorted To Voltage	Oxygen sensor input voltage maintained above normal operating range.
P0133 (M)	1/1 O2 Sensor Slow Response	Oxygen sensor response slower than minimum required switching frequency.
P0134 (M)	1/1 O2 Sensor Stays at Center	Neither rich or lean condition is detected from the oxygen sensor input.
P0135 (M)	1/1 O2 Sensor Heater Failure	Oxygen sensor heater element malfunction.
P0136 (M)	1/2 O2 Sensor Heater Circuit Malfunction	Oxygen sensor heater element malfunction.
P0137 (M)	1/2 O2 Sensor Shorted To Ground	Oxygen sensor input voltage maintained below normal operating range.
P0138 (M)	1/2 O2 Sensor Shorted To Voltage	Oxygen sensor input voltage maintained above normal operating range.
P0139 (M)	1/2 O2 Sensor Slow Response	Oxygen sensor response not as expected.
P0140 (M)	1/2 O2 Sensor Stays at Center	Neither rich or lean condition is detected from the oxygen sensor.
P0141 (M)	1/2 O2 Sensor Heater Failure	Oxygen sensor heater element malfunction.
P0143 (M)	1/3 O2 Sensor Shorted To Ground	Oxygen sensor input voltage maintained below normal operating range.
P0144 (M)	1/3 O2 Sensor Shorted To Voltage	Oxygen sensor input voltage maintained above normal operating range.
P0145 (M)	1/3 O2 Sensor Slow Response	Oxygen sensor response slower than minimum required switching frequency.
P0146 (M)	1/3 O2 Sensor Stays at Center	Neither rich or lean condition is detected from the oxygen sensor.
P0147 (M)	1/3 O2 Sensor Heater Failure	Oxygen sensor heater element malfunction.
P0151 (M)	2/1 O2 Sensor Shorted To Ground	Oxygen sensor input voltage maintained below normal operating range.
P0152 (M)	2/1 O2 Sensor Shorted To Voltage	Oxygen sensor input voltage sustained above normal operating range.
P0153 (M)	2/1 O2 Sensor Slow Response	Oxygen sensor response slower than minimum required switching frequency.
P0154 (M)	2/1 O2 Sensor Stays at Center	Neither rich or lean condition is detected from the oxygen sensor.
P0155 (M)	2/1 O2 Sensor Heater Failure	Oxygen sensor heater element malfunction.
P0157 (M)	2/2 O2 Sensor Shorted To Ground	Oxygen sensor input voltage maintained below normal operating range.
P0158 (M)	2/2 O2 Sensor Shorted To Voltage	Oxygen sensor input voltage maintained above normal operating range.
P0159	2/2 O2 Sensor Slow Response	Oxygen sensor response slower than minimum required switching frequency.
P0160 (M)	2/2 O2 Sensor Stays at Center	Neither rich or lean condition is detected from the oxygen sensor.

DESCRIPTION AND OPERATION (Continued)

(M) Malfunction Indicator Lamp (MIL) illuminated during engine operation if this DTC was recorded (depending if required by CARB and/or EPA). MIL is displayed as an engine icon on instrument panel.		
P0161 (M)	2/2 O2 Sensor Heater Failure	Oxygen sensor heater element malfunction.
P0168	Decreased Engine Performance Due To High Injection Pump Fuel Temp	Fuel temperature is above the engine protection limit. Engine power will be derated.
P0171 (M)	1/1 Fuel System Lean	A lean air/fuel mixture has been indicated by an abnormally rich correction factor.
P0172 (M)	1/1 Fuel System Rich	A rich air/fuel mixture has been indicated by an abnormally lean correction factor.
P0174 (M)	2/1 Fuel System Lean	A lean air/fuel mixture has been indicated by an abnormally rich correction factor.
P0175 (M)	2/1 Fuel System Rich	A rich air/fuel mixture has been indicated by an abnormally lean correction factor.
P0176	Loss of Flex Fuel Calibration Signal	No calibration voltage present from flex fuel sensor.
P0177	Water In Fuel	Excess water found in fuel by water-in-fuel sensor.
P0178	Flex Fuel Sensor Volts Too Low	Flex fuel sensor input below minimum acceptable voltage.
P0178	Water In Fuel Sensor Voltage Too Low	Loss of water-in-fuel circuit or sensor.
P0179	Flex Fuel Sensor Volts Too High	Flex fuel sensor input above maximum acceptable voltage.
P0181	Fuel Injection Pump Failure	Low power, engine derated, or engine stops.
P0182 (M)	CNG Temp Sensor Voltage Too Low	Compressed natural gas temperature sensor voltage below acceptable voltage.
P0183 (M)	CNG Temp Sensor Voltage Too High	Compressed natural gas temperature sensor voltage above acceptable voltage.
P0201 (M)	Injector #1 Control Circuit	An open or shorted condition detected in control circuit for injector #1 or the INJ 1 injector bank.
P0202 (M)	Injector #2 Control Circuit	An open or shorted condition detected in control circuit for injector #2 or the INJ 2 injector bank.
P0203 (M)	Injector #3 Control Circuit	An open or shorted condition detected in control circuit for injector #3 or the INJ 3 injector bank.
P0204 (M)	Injector #4 Control Circuit	Injector #4 or INJ 4 injector bank output driver stage does not respond properly to the control signal.
P0205 (M)	Injector #5 Control Circuit	Injector #5 output driver stage does not respond properly to the control signal.
P0206 (M)	Injector #6 Control Circuit	Injector #6 output driver stage does not respond properly to the control signal.
P0207 (M)	Injector #7 Control Circuit	Injector #7 output driver stage does not respond properly to the control signal.
P0208 (M)	Injector #8 Control Circuit	Injector #8 output driver stage does not respond properly to the control signal.
P0209 (M)	Injector #9 Control Circuit	Injector #9 output driver stage does not respond properly to the control signal.
P0210 (M)	Injector #10 Control Circuit	Injector #10 output driver stage does not respond properly to the control signal.
P0215	Fuel Injection Pump Control Circuit	Failure in fuel pump relay control circuit.

DESCRIPTION AND OPERATION (Continued)

(M) Malfunction Indicator Lamp (MIL) illuminated during engine operation if this DTC was recorded (depending if required by CARB and/or EPA). MIL is displayed as an engine icon on instrument panel.		
P0216 (M)	Fuel Injection Pump Timing Failure	High fuel supply restriction, low fuel pressure or possible wrong or incorrectly installed pump keyway.
P0217	Decreased Engine Performance Due To Engine Overheat Condition	Engine overheating. ECM will derate engine performance.
P0219	Crankshaft Position Sensor Overspeed Signal	Engine has exceeded rpm limits.
P0222 (M)	Idle Validation Signals Both Low	Problem detected with idle validation circuits within APPS.
P0223 (M)	Idle Validation Signals Both High (Above 5 Volts)	Problem detected with idle validation circuits within APPS.
P0230	Transfer Pump (Lift Pump) Circuit Out of Range	Problem detected in fuel transfer pump circuits.
P0232	Fuel Shutoff Signal Voltage Too High	Fuel shut-off signal voltage too high from ECM to fuel injection pump.
P0234 (M)	Turbo Boost Limit Exceeded	Problem detected in turbocharger wastegate.
P0236 (M)	Map Sensor Too High Too Long	Problem detected in turbocharger wastegate.
P0237 (M)	Map Sensor Voltage Too Low	MAP sensor voltage input below the minimum acceptable voltage.
P0238 (M)	Map Sensor Voltage Too High	MAP sensor voltage input above the maximum acceptable voltage.
P0251 (M)	Fuel Inj. Pump Mech. Failure Fuel Valve Feedback Circuit	Problem sensed with fuel circuit internal to fuel injection pump.
P0253 (M)	Fuel Injection Pump Fuel Valve Open Circuit	Problem sensed with fuel circuit internal to fuel injection pump.
P0254	Fuel Injection Pump Fuel Valve Current Too High	Problem caused by internal fuel injection pump failure.
P0300 (M)	Multiple Cylinder Mis-fire	Misfire detected in multiple cylinders.
P0301 (M)	CYLINDER #1 MISFIRE	Misfire detected in cylinder #1.
P0302 (M)	CYLINDER #2 MISFIRE	Misfire detected in cylinder #2.
P0303 (M)	CYLINDER #3 MISFIRE	Misfire detected in cylinder #3.
P0304 (M)	CYLINDER #4 MISFIRE	Misfire detected in cylinder #4.
P0305 (M)	CYLINDER #5 MISFIRE	Misfire detected in cylinder #5.
P0306 (M)	CYLINDER #6 MISFIRE	Misfire detected in cylinder #6.
P0307 (M)	CYLINDER #7 MISFIRE	Misfire detected in cylinder #7.
P0308 (M)	CYLINDER #8 MISFIRE	Misfire detected in cylinder #8.
P0309 (M)	CYLINDER #9 MISFIRE	Misfire detected in cylinder #9.
P0310 (M)	CYLINDER #10 MISFIRE	Misfire detected in cylinder #10.
P0320 (M)	No Crank Referance Signal at PCM	No reference signal (crankshaft position sensor) detected during engine cranking.
P0320 (M)	No RPM Signal to PCM (Crankshaft Position Sensor Signal to JTEC)	A CKP signal has not been detected at the PCM.
P0325	Knock Sensor #1 Circuit	Knock sensor (#1) signal above or below minimum acceptable threshold voltage at particular engine speeds.

DESCRIPTION AND OPERATION (Continued)

(M) Malfunction Indicator Lamp (MIL) illuminated during engine operation if this DTC was recorded (depending if required by CARB and/or EPA). MIL is displayed as an engine icon on instrument panel.		
P0330	Knock Sensor #2 Circuit	Knock sensor (#2) signal above or below minimum acceptable threshold voltage at particular engine speeds.
P0336 (M)	Crankshaft Position (CKP) Sensor Signal	Problem with voltage signal from CKP.
P0340 (M)	No Cam Signal At PCM	No fuel sync
P0341 (M)	Camshaft Position (CMP) Sensor Signal	Problem with voltage signal from CMP.
P0350	Ignition Coil Draws Too Much Current	A coil (1-5) is drawing too much current.
P0351 (M)	Ignition Coil # 1 Primary Circuit	Peak primary circuit current not achieved with maximum dwell time.
P0352 (M)	Ignition Coil # 2 Primary Circuit	Peak primary circuit current not achieved with maximum dwell time.
P0353 (M)	Ignition Coil # 3 Primary Circuit	Peak primary circuit current not achieved with maximum dwell time.
P0354 (M)	Ignition Coil # 4 Primary Circuit	Peak primary circuit current not achieved with maximum dwell time (High Impedance).
P0355 (M)	Ignition Coil # 5 Primary Circuit	Peak primary circuit current not achieved with maximum dwell time (High Impedance).
P0356 (M)	Ignition Coil # 6 Primary Circuit	Peak primary circuit current not achieved with maximum dwell time (high impedance).
P0357 (M)	Ignition Coil # 7 Primary Circuit	Peak primary circuit current not achieved with maximum dwell time (high impedance).
P0358 (M)	Ignition Coil # 8 Primary Circuit	Peak primary circuit current not achieved with maximum dwell time (high impedance).
P0370	Fuel Injection Pump Speed/Position Sensor Sig Lost	Problem caused by internal fuel injection pump failure.
P0380 (M)	Intake Air Heater Relay #1 Control Circuit	Problem detected in #1 air heater solenoid/relay circuit (not heater element)
P0381 (M)	Wait To Start Lamp Inoperative	Problem detected in wait-to-start bulb circuit.
P0382 (M)	Intake Air Heater Relay #2 Control Circuit	Problem detected in #2 air heater solenoid/relay circuit (not heater element)
P0387	Crankshaft Position Sensor Supply Voltage Too Low	CKP sensor voltage input below the minimum acceptable voltage.
P0388	Crankshaft Position Sensor Supply Voltage Too High	CKP sensor voltage input above the maximum acceptable voltage.
P0401	EGR System Failure	Required change in air/fuel ration not detected during diagnostic test.
P0403	EGR Solenoid Circuit	An open or shorted condition detected in the EGR solenoid control circuit.
P0404	EGR Position Sensor Rationality	EGR position sensor signal does not correlate to EGR duty cycle.
P0405	EGR Position Sensor Volts Too Low	EGR position sensor input below the acceptable voltage range.

DESCRIPTION AND OPERATION (Continued)

(M) Malfunction Indicator Lamp (MIL) illuminated during engine operation if this DTC was recorded (depending if required by CARB and/or EPA). MIL is displayed as an engine icon on instrument panel.		
P0406	EGR Position Sensor Volts Too High	EGR position sensor input above the acceptable voltage range.
P0412	Secondary Air Solenoid Circuit	An open or shorted condition detected in the secondary air (air switching/aspirator) solenoid control circuit.
P0420 (M)	1/1 Catalytic Converter Efficiency	Catalyst 1/1 efficiency below required level.
P0432 (M)	1/2 Catalytic Converter Efficiency	Catalyst 2/1 efficiency below required level.
P0441 (M)	Evap Purge Flow Monitor	Insufficient or excessive vapor flow detected during evaporative emission system operation.
P0442 (M)	Evap Leak Monitor Medium Leak Detected	A small leak has been detected in the evaporative system.
P0443 (M)	Evap Purge Solenoid Circuit	An open or shorted condition detected in the EVAP purge solenoid control circuit.
P0455 (M)	Evap Leak Monitor Large Leak Detected	A large leak has been detected in the evaporative system.
P0456 (M)	Evap Leak Monitor Small Leak Detected	Leak has been detected in the evaporative system.
P0460	Fuel Level Unit No Change Over Miles	During low fuel
P0460	Fuel Level Unit No Change Over Miles	Fuel level sending unit voltage does not change for more than 40 miles.
P0462	Fuel Level Sending Unit Volts Too Low	Fuel level sensor input below acceptable voltage.
P0462 (M)	Fuel Level Sending Unit Volts Too Low	Open circuit between PCM and fuel gauge sending unit.
P0463	Fuel Level Sending Unit Volts Too High	Fuel level sensor input above acceptable voltage.
P0463 (M)	Fuel Level Sending Unit Volts Too High	Circuit shorted to voltage between PCM and fuel gauge sending unit.
P0500 (M)	No Vehicle Speed Sensor Signal	No vehicle speed sensor signal detected during road load conditions.
P0500 (M)	No Vehicle Speed Sensor Signal	A vehicle speed signal was not detected.
P0505 (M)	Idle Air Control Motor Circuits	SBEC II
P0522	Oil Pressure Voltage Too Low	Oil pressure sending unit (sensor) voltage input below the minimum acceptable voltage.
P0523	Oil Pressure Voltage Too High	Oil pressure sending unit (sensor) voltage input above the maximum acceptable voltage.
P0524	Oil Pressure Too Low	Engine oil pressure is low. Engine power derated.
P0545	A/C Clutch Relay Circuit	Problem detected in air conditioning clutch relay control circuit.
P0551	Power Steering Switch Failure	Incorrect input state detected for the power steering switch circuit. PL: High pressure seen at high speed.
P0562	Charging System Voltage Too Low	Supply voltage sensed at ECM too low.
P0563	Charging System Voltage Too High	Supply voltage sensed at ECM too high.

DESCRIPTION AND OPERATION (Continued)

(M) Malfunction Indicator Lamp (MIL) illuminated during engine operation if this DTC was recorded (depending if required by CARB and/or EPA). MIL is displayed as an engine icon on instrument panel.		
P0600	PCM Failure SPI Communications	No communication detected between co-processors in the control module.
P0601 (M)	Internal Controller Failure	Internal control module fault condition (check sum) detected.
P0602 (M)	ECM Fueling Calibration Error	ECM Internal fault condition detected.
P0604	RAM Check Failure	Transmission control module RAM self test fault detected. -Aisin transmission
P0605	ROM Check Failure	Transmission control module ROM self test fault detected -Aisin transmission
P0606 (M)	ECM Failure	ECM Internal fault condition detected.
P0615	Starter Relay Control Circuit	An open or shorted condition detected in the starter relay control circuit.
P0622 (G)	Generator Field Not Switching Properly	An open or shorted condition detected in the generator field control circuit.
P0645	A/C Clutch Relay Circuit	An open or shorted condition detected in the A/C clutch relay control circuit.
P0700	EATX Controller DTC Present	This SBEC III or JTEC DTC indicates that the EATX or Aisin controller has an active fault and has illuminated the MIL via a CCD (EATX) or SCI (Aisin) message. The specific fault must be acquired from the EATX via CCD or from the Aisin via ISO-9141.
P0703	Brake Switch Stuck Pressed or Released	Incorrect input state detected in the brake switch circuit. (Changed from P1595)
P0711 (M)	Trans Temp Sensor, No Temp Rise After Start	Relationship between the transmission temperature and overdrive operation and/or TCC operation indicates a failure of the Transmission Temperature Sensor. OBD II Rationality. Was MIL code 37.
P0712	Trans Temp Sensor Voltage Too Low	Transmission fluid temperature sensor input below acceptable voltage. Was MIL code 37.
P0712 (M)	Trans Temp Sensor Voltage Too Low	Voltage less than 1.55 volts (4-speed auto. trans. only).
P0713	Trans Temp Sensor Voltage Too High	Transmission fluid temperature sensor input above acceptable voltage. Was MIL code 37.
P0713 (M)	Trans Temp Sensor Voltage Too High	Voltage greater than 3.76 volts (4-speed auto. trans. only).
P0720 (M)	Low Output SPD Sensor RPM, Above 15 MPH	The relationship between the Output Shaft Speed Sensor and vehicle speed is not within acceptable limits.
P0720 (M)	Low Output Spd Sensor RPM Above 15 mph	Output shaft speed is less than 60 rpm with vehicle speed above 15 mph (4-speed auto. trans. only).
P0740 (M)	Torq Con Clu, No RPM Drop at Lockup	Relationship between engine and vehicle speeds indicated failure of torque convertor clutch lock-up system (TCC/PTU solenoid)
P0743 (M)	Torque Converter Clutch Solenoid/ Trans Relay Circuits	An open or shorted condition detected in the torque converter clutch (part throttle unlock) solenoid control circuit. Shift solenoid C electrical fault - Aisin transmission

DESCRIPTION AND OPERATION (Continued)

(M) Malfunction Indicator Lamp (MIL) illuminated during engine operation if this DTC was recorded (depending if required by CARB and/or EPA). MIL is displayed as an engine icon on instrument panel.		
P0743 (M)	Torque Converter Clutch Solenoid/ Trans Relay Circuits	An open or shorted condition detected in the torque converter part throttle unlock solenoid control circuit (3 or 4-speed auto. trans. only).
P0748 (M)	Governor Pressur Sol Control/Trans Relay Circuits	An open or shorted condition detected in the Governor Pressure Solenoid circuit or Trans Relay Circuit in JTEC RE transmissions.
P0748 (M)	Governor Pressure Sol Control/Trans Relay Circuits	An open or shorted condition detected in the governor pressure solenoid or relay circuits (4-speed auto. trans. only).
P0751 (M)	O/D Switch Pressed (Lo) More Than 5 Minutes	Overdrive override switch input is in a prolonged depressed state.
P0751 (M)	O/D Switch Pressed (LO) More Than 5 Min	Overdrive Off switch input too low for more than 5 minutes (4-speed auto. trans. only).
P0753 (M)	Trans 3-4 Shift Sol/Trans Relay Circuits	An open or shorted condition detected in the overdrive solenoid control circuit or Trans Relay Circuit in JTEC RE transmissions. Was MIL code 45.
P0753 (M)	Trans 3-4 Shift Sol/Trans Relay Circuits	An open or shorted condition detected in the transmission 2-4 shift solenoid circuit (4-speed auto. trans. only).
P0756	AW4 Shift Sol B (2-3) Functional Failure	Shift solenoid B (2-3) functional fault - Aisin transmission
P0783 (M)	3-4 Shift Sol, No RPM Drop at Lockup	The overdrive solenoid is unable to engage the gear change from 3rd gear to the overdrive gear.
P0801	Reverse Gear Lockout Circuit Open or Short	An open or shorted condition detected in the transmission reverse gear lock-out solenoid control circuit.
P0830	Clutch Depressed Switch Circuit	Problem detected in clutch switch circuit.
P0833	Clutch Released Switch Circuit	Problem detected in clutch switch circuit.
P1110	Decrease Engine Performance Due To High Intake Air Temperature	Intake manifold air temperature is above the engine protection limit. Engine power will be derated.
P1180	Decreased Engine Performance Due To High Injection Pump Fuel Temp	Fuel temperature is above the engine protection limit. Engine power will be derated.
P1195 (M)	1/1 O2 Sensor Slow During Catalyst Monitor	A slow switching oxygen sensor has been detected in bank 1/1 during catalyst monitor test. (Also see SCI DTC \$66) (was P0133)
P1196 (M)	2/1 O2 Sensor Slow During Catalyst Monitor	A slow switching oxygen sensor has been detected in bank 2/1 during catalyst monitor test. (Also see SCI DTC \$7A) (was P0153)
P1197	1/2 O2 Sensor Slow During Catalyst Monitor	A slow switching oxygen sensor has been detected in bank 1/2 during catalyst monitor test. (Also see SCI DTC \$68) (was P0139)
P1198	Radiator Temperature Sensor Volts Too High	Radiator coolant temperature sensor input above the maximum acceptable voltage.
P1199	Radiator Temperature Sensor Volts Too Low	Radiator coolant temperature sensor input below the minimum acceptable voltage.
P1281	Engine is Cold Too Long	Engine coolant temperature remains below normal operating temperatures during vehicle travel (Thermostat).

DESCRIPTION AND OPERATION (Continued)

(M) Malfunction Indicator Lamp (MIL) illuminated during engine operation if this DTC was recorded (depending if required by CARB and/or EPA). MIL is displayed as an engine icon on instrument panel.		
P1282	Fuel Pump Relay Control Circuit	An open or shorted condition detected in the fuel pump relay control circuit.
P1283	Idle Select Signal Invalid	ECM or fuel injection pump module internal fault condition detected.
P1284 (M)	Fuel Injection Pump Battery Voltage Out-Of-Range	Fuel injection pump module internal fault condition detected. Engine power will be derated.
P1285 (M)	Fuel Injection Pump Controller Always On	Fuel injection pump module relay circuit failure detected. Engine power will be derated.
P1286	Accelerator Position Sensor (APPS) Supply Voltage Too High	High voltage detected at APPS.
P1287	Fuel Injection Pump Controller Supply Voltage Low	ECM or fuel injection pump module internal fault condition detected. Engine power will be derated.
P1288	Intake Manifold Short Runner Solenoid Circuit	An open or shorted condition detected in the short runner tuning valve circuit.
P1289	Manifold Tune Valve Solenoid Circuit	An open or shorted condition detected in the manifold tuning valve solenoid control circuit.
P1290	CNG Fuel System Pressure Too High	Compressed natural gas system pressure above normal operating range.
P1291	No Temp Rise Seen From Intake Heaters	Energizing Heated Air Intake does not change intake air temperature sensor an acceptable amount.
P1291 (M)	No Temperature Rise Seen From Intake Air Heaters	Problem detected in intake manifold air heating system.
P1292	CNG Pressure Sensor Voltage Too High	Compressed natural gas pressure sensor reading above acceptable voltage.
P1293	CNG Pressure Sensor Voltage Too Low	Compressed natural gas pressure sensor reading below acceptable voltage.
P1294 (M)	Target Idle Not Reached	Target RPM not achieved during drive idle condition. Possible vacuum leak or IAC (AIS) lost steps.
P1295 (M)	No 5 Volts to TP Sensor	Loss of a 5 volt feed to the Throttle Position Sensor has been detected.
P1295 (M)	Accelerator Position Sensor (APPS) Supply Voltage Too Low	APPS supply voltage input below the minimum acceptable voltage.
P1296	No 5 Volts to MAP Sensor	Loss of a 5 volt feed to the MAP Sensor has been detected.
P1297 (M)	No Change in MAP From Start To Run	No difference is recognized between the MAP reading at engine idle and the stored barometric pressure reading.
P1298	Lean Operation at Wide Open Throttle	A prolonged lean condition is detected during Wide Open Throttle
P1299	Vacuum Leak Found (IAC Fully Seated)	MAP Sensor signal does not correlate to Throttle Position Sensor signal. Possible vacuum leak.
P1388	Auto Shutdown Relay Control Circuit	An open or shorted condition detected in the ASD or CNG shutoff relay control ckt.
P1388	Auto Shutdown Relay Control Circuit	An open or shorted condition detected in the auto shutdown relay circuit.

DESCRIPTION AND OPERATION (Continued)

(M) Malfunction Indicator Lamp (MIL) illuminated during engine operation if this DTC was recorded (depending if required by CARB and/or EPA). MIL is displayed as an engine icon on instrument panel.		
P1389	No ASD Relay Output Voltage At PCM	No Z1 or Z2 voltage sensed when the auto shutdown relay is energized.
P1389 (M)	No ASD Relay Output Voltage at PCM	An open condition detected in the ASD relay output circuit.
P1390	Timing Belt Skipped 1 Tooth or More	Relationship between Cam and Crank signals not correct
P1391 (M)	Intermittent Loss of CMP or CKP	Loss of the Cam Position Sensor or Crank Position sensor has occurred. For PL 2.0L
P1398 (M)	Mis-Fire Adaptive Numerator at Limit	PCM is unable to learn the Crank Sensor's signal in preparation for Misfire Diagnostics. Probable defective Crank Sensor
P1399	Wait To Start Lamp Circuit	An open or shorted condition detected in the Wait to Start Lamp circuit.
P1403	No 5V to EGR Sens	Loss of 5v feed to the EGR position sensor.
P01475	Aux 5 Volt Supply Voltage High	Sensor supply voltage for ECM sensors is too high.
P1476	Too Little Secondary Air	Insufficient flow of secondary air injection detected during aspirator test (was P0411)
P1477	Too Much Secondary Air	Excessive flow of secondary air injection detected during aspirator test (was P0411).
P1478	Battery Temp Sensor Volts Out of Limit	Internal temperature sensor input voltage out of an acceptable range.
P1479	Transmission Fan Relay Circuit	An open or shorted condition detected in the transmission fan relay circuit.
P1480	PCV Solenoid Circuit	An open or shorted condition detected in the PCV solenoid circuit.
P1481	EATX RPM Pulse Perf	EATX RPM pulse generator signal for misfire detection does not correlate with expected value.
P1482	Catalyst Temperature Sensor Circuit Shorted Low	Catalyst temperature sensor circuit shorted low.
P1483	Catalyst Temperature Sensor Circuit Shorted High.	Catalyst temperature sensor circuit shorted high.
P1484	Catalytic Converter Overheat Detected	A catalyst overheat condition has been detected by the catalyst temperature sensor.
P1485	Air Injection Solenoid Circuit	An open or shorted condition detected in the air assist solenoid circuit.
P1486	Evap Leak Monitor Pinched Hose Found	LDP has detected a pinched hose in the evaporative hose system.
P1487	Hi Speed Rad Fan CTRL Relay Circuit	An open or shorted condition detected in the control circuit of the #2 high speed radiator fan control relay.
P1488	Auxiliary 5 Volt Supply Output Too Low	Auxiliary 5 volt sensor feed is sensed to be below an acceptable limit.
P1488	5 Volt Supply Voltage Low	Sensor supply voltage for ECM sensors is too low.
P1489	High Speed Fan CTRL Relay Circuit	An open or shorted condition detected in the control circuit of the high speed radiator fan control relay.
P1490	Low Speed Fan CTRL Relay Circuit	An open or shorted condition detected in control circuit of the low speed radiator fan control relay.

DESCRIPTION AND OPERATION (Continued)

(M) Malfunction Indicator Lamp (MIL) illuminated during engine operation if this DTC was recorded (depending if required by CARB and/or EPA). MIL is displayed as an engine icon on instrument panel.		
P1491	Rad Fan Control Relay Circuit	An open or shorted condition detected in the radiator fan control relay control circuit. This includes PWM solid state relays.
P1492	Ambient/Batt Temp Sen Volts Too High	External temperature sensor input above acceptable voltage.
P1492 (M)	Ambient/Batt Temp Sensor Volts Too High	Battery temperature sensor input voltage above an acceptable range.
P1493 (M)	Ambient/Batt Temp Sen Volts Too Low	External temperature sensor input below acceptable voltage.
P1493 (M)	Ambient/Batt Temp Sen Volts Too Low	Battery temperature sensor input voltage below an acceptable range.
P1494 (M)	Leak Detection Pump Sw or Mechanical Fault	Incorrect input state detected for the Leak Detection Pump (LDP) pressure switch.
P1495	Leak Detection Pump Solenoid Circuit	An open or shorted condition detected in the Leak Detection Pump (LDP) solenoid circuit.
P1496	5 Volt Supply, Output Too Low	5 volt sensor feed is sensed to be below an acceptable limit. (less than 4v for 4 sec)
P1498	High Speed Rad Fan Ground CTRL Rly Circuit	An open or shorted condition detected in the control circuit of the #3 high speed radiator fan control relay.
P1594 (G)	Charging System Voltage Too High	Battery voltage sense input above target charging voltage during engine operation.
P1594	Charging System Voltage Too High	Battery voltage sense input above target charging voltage during engine operation.
P1595	Speed Control Solenoid Circuits	An open or shorted condition detected in either of the speed control vacuum or vent solenoid control circuits.
P1595	Speed Control Solenoid Circuits	An open or shorted condition detected in the speed control vacuum or vent solenoid circuits.
P1596	Speed Control Switch Always High	Speed control switch input above maximum acceptable voltage.
P1597	Speed Control Switch Always Low	Speed control switch input below minimum acceptable voltage.
P1597	Speed Control Switch Always Low	Speed control switch input below the minimum acceptable voltage.
P1598	A/C Pressure Sensor Volts Too High	A/C pressure sensor input above maximum acceptable voltage.
P1598	A/C Sensor Input Hi	Problem detected in air conditioning electrical circuit.
P1599	A/C Pressure Sensor Volts Too Low	A/C pressure sensor input below minimum acceptable voltage.
P1599	A/C Sensor Input Lo	Problem detected in air conditioning electrical circuit.
P1680	Clutch Released Switch Circuit	Problem detected in clutch switch electrical circuit.
P1681	No I/P Cluster CCD/J1850 Messages Received	No CCD/J1850 messages received from the cluster control module.

DESCRIPTION AND OPERATION (Continued)

(M) Malfunction Indicator Lamp (MIL) illuminated during engine operation if this DTC was recorded (depending if required by CARB and/or EPA). MIL is displayed as an engine icon on instrument panel.		
P1682 (G)	Charging System Voltage Too Low	Battery voltage sense input below target charging voltage during engine operation and no significant change in voltage detected during active test of generator output circuit.
P1682	Charging System Voltage Too Low	Charging system output voltage low.
P1683	SPD CTRL PWR Relay; or S/C 12v Driver CKT	An open or shorted condition detected in the speed control servo power control circuit.
P1683	Spd ctrl pwr rly, or s/c 12v driver circuit	An open or shorted condition detected in the speed control servo power control circuit.
P1684	Batt Loss in 50 Star	The battery has been disconnected within the last 50 starts
P1685	SKIM Invalid Key	The engine controller has received an invalid key from the SKIM.
P1686	No SKIM BUS Messages Received	No CCD/J1850 messages received from the Smart Key Immobilizer Module (SKIM).
P1687	No MIC BUS Message	No CCD/J1850 messages received from the Mechanical Instrument Cluster (MIC) module.
P1688 (M)	Internal Fuel Injection Pump Controller Failure	Internal problem within the fuel injection pump. Low power, engine derated, or engine stops.
P1689 (M)	No Communication Between ECM and Injection Pump Module	Data link circuit failure between ECM and fuel injection pump. Low power, engine derated, or engine stops.
P1690 (M)	Fuel Injection Pump CKP Sensor Does Not Agree With ECM CKP Sensor	Problem in fuel sync signal. Possible injection pump timing problem. Low power, engine derated, or engine stops.
P1691	Fuel Injection Pump Controller Calibration Error	Internal fuel injection pump failure. Low power, engine derated, or engine stops.
P1692	DTC Set In ECM	A "Companion DTC" was set in both the ECM and PCM.
P1693 (M)	DTC Detected in Companion Module	A fault has been generated in the companion engine control module.
P1693 (M)	DTC Detected in PCM/ECM or DTC Detected in ECM	A "Companion DTC" was set in both the ECM and PCM.
P1694	Fault In Companion Module	No CCD/J1850 messages received from the powertrain control module-Aisin transmission
P1694 (M)	No CCD Messages received from ECM	Bus communication failure to PCM.
P1695	No CCD/J1850 Message From Body Control Module	No CCD/J1850 messages received from the body control module.
P1696	PCM Failure EEPROM Write Denied	Unsuccessful attempt to write to an EEPROM location by the control module.
P1697	PCM Failure SRI Mile Not Stored	Unsuccessful attempt to update Service Reminder Indicator (SRI or EMR) mileage in the control module EEPROM.
P1698	No CCD/J1850 Message From TCM	No CCD/J1850 messages received from the electronic transmission control module (EATX) or the Aisin transmission controller.

DESCRIPTION AND OPERATION (Continued)

(M) Malfunction Indicator Lamp (MIL) illuminated during engine operation if this DTC was recorded (depending if required by CARB and/or EPA). MIL is displayed as an engine icon on instrument panel.		
P1698	No CCD Messages received from PCM	Bus communication failure to PCM. A "Companion DTC" was set in both the ECM and PCM.
P1719	Skip Shift Solenoid Circuit	An open or shorted condition detected in the transmission 2-3 gear lock-out solenoid control circuit.
P1740	TCC or OD Sol Perf	A rationality error has been detected in either the TCC solenoid or overdrive solenoid systems.
P1740 (M)	TCC OR O/D Solenoid Performance	Problem detected in transmission convertor clutch and/or overdrive circuits (diesel engine with 4-speed auto. trans. only).
P1756 (M)	GOV Press Not Equal to Target @ 15-20 PSI	The requested pressure and the actual pressure are not within a tolerance band for the Governor Control System which is used to regulate governor pressure to control shifts for 1st, 2nd, and 3rd gear. (Mid Pressure Malfunction)
P1756 (M)	Governor Pressure Not Equal to Target @ 15-20 PSI	Governor sensor input not between 10 and 25 psi when requested (4-speed auto. trans. only).
P1757	GOV Press Not Equal to Target @ 15-20 PSI	The requested pressure and the actual pressure are not within a tolerance band for the Governor Control System which is used to regulate governor pressure to control shifts for 1st, 2nd, and 3rd gear (Zero Pressure Malfunction)
P1757 (M)	Governor Pressure Above 3 PSI In Gear With 0 MPH	Governor pressure greater than 3 psi when requested to be 0 psi (4-speed auto. trans. only).
P1762 (M)	Gov Press Sen Offset Volts Too Low or High	The Governor Pressure Sensor input is greater than a calibration limit or is less than a calibration limit for 3 consecutive park/neutral calibrations.
P1762 (M)	Governor Press Sen Offset Volts Too Low or High	Sensor input greater or less than calibration for 3 consecutive Neutral/Park occurrences (4-speed auto. trans. only).
P1763	Governor Pressure Sensor Volts Too Hi	The Governor Pressure Sensor input is above an acceptable voltage level.
P1763 (M)	Governor Pressure Sensor Volts Too HI	Voltage greater than 4.89 volts (4-speed auto. trans. only).
P1764 (M)	Governor Pressure Sensor Volts Too Low	The Governor Pressure Sensor input is below an acceptable voltage level.
P1764 (M)	Governor Pressure Sensor Volts Too Low	Voltage less than .10 volts (4-speed auto. trans. only).
P1765 (M)	Trans 12 Volt Supply Relay CTRL Circuit	An open or shorted condition is detected in the Transmission Relay control circuit. This relay supplies power to the TCC
P1765 (M)	Trans 12 Volt Supply Relay Ctrl Circuit	Current state of solenoid output port is different than expected (4-speed auto. trans. only).
P1899 (M)	P/N Switch Stuck in Park or in Gear	Incorrect input state detected for the Park/Neutral switch.
P1899 (M)	P/N Switch Stuck in Park or in Gear	Incorrect input state detected for the Park/Neutral switch (3 or 4-speed auto. trans. only).

DESCRIPTION AND OPERATION (Continued)

TASK MANAGER

DESCRIPTION

The PCM is responsible for efficiently coordinating the operation of all the emissions-related components. The PCM is also responsible for determining if the diagnostic systems are operating properly. The software designed to carry out these responsibilities is called the 'Task Manager'.

OPERATION

The Task Manager determines which tests happen when and which functions occur when. Many of the diagnostic steps required by OBD II must be performed under specific operating conditions. The Task Manager software organizes and prioritizes the diagnostic procedures. The job of the Task Manager is to determine if conditions are appropriate for tests to be run, monitor the parameters for a trip for each test, and record the results of the test. Following are the responsibilities of the Task Manager software:

- Test Sequence
- MIL Illumination
- Diagnostic Trouble Codes (DTCs)
- Trip Indicator
- Freeze Frame Data Storage
- Similar Conditions Window

Test Sequence

In many instances, emissions systems must fail diagnostic tests more than once before the PCM illuminates the MIL. These tests are known as 'two trip monitors.' Other tests that turn the MIL lamp on after a single failure are known as 'one trip monitors.' A trip is defined as 'start the vehicle and operate it to meet the criteria necessary to run the given monitor.'

Many of the diagnostic tests must be performed under certain operating conditions. However, there are times when tests cannot be run because another test is in progress (conflict), another test has failed (pending) or the Task Manager has set a fault that may cause a failure of the test (suspend).

- Pending

Under some situations the Task Manager will not run a monitor if the MIL is illuminated and a fault is stored from another monitor. In these situations, the Task Manager postpones monitors **pending** resolution of the original fault. The Task Manager does not run the test until the problem is remedied.

For example, when the MIL is illuminated for an Oxygen Sensor fault, the Task Manager does not run the Catalyst Monitor until the Oxygen Sensor fault is remedied. Since the Catalyst Monitor is based on signals from the Oxygen Sensor, running the test would produce inaccurate results.

- Conflict

There are situations when the Task Manager does not run a test if another monitor is in progress. In these situations, the effects of another monitor running could result in an erroneous failure. If this **conflict** is present, the monitor is not run until the conflicting condition passes. Most likely the monitor will run later after the conflicting monitor has passed.

For example, if the Fuel System Monitor is in progress, the Task Manager does not run the EGR Monitor. Since both tests monitor changes in air/fuel ratio and adaptive fuel compensation, the monitors will conflict with each other.

- Suspend

Occasionally the Task Manager may not allow a two trip fault to mature. The Task Manager will **suspend** the maturing of a fault if a condition exists that may induce an erroneous failure. This prevents illuminating the MIL for the wrong fault and allows more precise diagnosis.

For example, if the PCM is storing a one trip fault for the Oxygen Sensor and the EGR monitor, the Task Manager may still run the EGR Monitor but will suspend the results until the Oxygen Sensor Monitor either passes or fails. At that point the Task Manager can determine if the EGR system is actually failing or if an Oxygen Sensor is failing.

MIL Illumination

The PCM Task Manager carries out the illumination of the MIL. The Task Manager triggers MIL illumination upon test failure, depending on monitor failure criteria.

The Task Manager Screen shows both a Requested MIL state and an Actual MIL state. When the MIL is illuminated upon completion of a test for a third trip, the Requested MIL state changes to OFF. However, the MIL remains illuminated until the next key cycle. (On some vehicles, the MIL will actually turn OFF during the third key cycle) During the key cycle for the third good trip, the Requested MIL state is OFF, while the Actual MIL state is ON. After the next key cycle, the MIL is not illuminated and both MIL states read OFF.

Diagnostic Trouble Codes (DTCs)

With OBD II, different DTC faults have different priorities according to regulations. As a result, the priorities determine MIL illumination and DTC erasure. DTCs are entered according to individual priority. DTCs with a higher priority overwrite lower priority DTCs.

Priorities

- Priority 0 —Non-emissions related trouble codes

DESCRIPTION AND OPERATION (Continued)

- Priority 1 — One trip failure of a two trip fault for non-fuel system and non-misfire.
- Priority 2 — One trip failure of a two trip fault for fuel system (rich/lean) or misfire.
- Priority 3 — Two trip failure for a non-fuel system and non-misfire or matured one trip comprehensive component fault.
- Priority 4 — Two trip failure or matured fault for fuel system (rich/lean) and misfire or one trip catalyst damaging misfire.

Non-emissions related failures have no priority. One trip failures of two trip faults have low priority. Two trip failures or matured faults have higher priority. One and two trip failures of fuel system and misfire monitor take precedence over non-fuel system and non-misfire failures.

DTC Self Erasure

With one trip components or systems, the MIL is illuminated upon test failure and DTCs are stored.

Two trip monitors are components requiring failure in two consecutive trips for MIL illumination. Upon failure of the first test, the Task Manager enters a maturing code. If the component fails the test for a second time the code matures and a DTC is set.

After three good trips the MIL is extinguished and the Task Manager automatically switches the trip counter to a warm-up cycle counter. DTCs are automatically erased following 40 warm-up cycles if the component does not fail again.

For misfire and fuel system monitors, the component must pass the test under a Similar Conditions Window in order to record a good trip. A Similar Conditions Window is when engine RPM is within ± 375 RPM and load is within $\pm 10\%$ of when the fault occurred.

NOTE: It is important to understand that a component does not have to fail under a similar window of operation to mature. It must pass the test under a Similar Conditions Window when it failed to record a Good Trip for DTC erasure for misfire and fuel system monitors.

DTCs can be erased anytime with a DRB III. Erasing the DTC with the DRB III erases all OBD II information. The DRB III automatically displays a warning that erasing the DTC will also erase all OBD II monitor data. This includes all counter information for warm-up cycles, trips and Freeze Frame.

Trip Indicator

The **Trip** is essential for running monitors and extinguishing the MIL. In OBD II terms, a trip is a set of vehicle operating conditions that must be met for a specific monitor to run. All trips begin with a key cycle.

Good Trip

The Good Trip counters are as follows:

- Specific Good Trip
- Fuel System Good Trip
- Misfire Good Trip
- Alternate Good Trip (appears as a Global Good Trip on DRB III)
- Comprehensive Components
- Major Monitor
- Warm-Up Cycles

Specific Good Trip

The term Good Trip has different meanings depending on the circumstances:

- If the MIL is OFF, a trip is defined as when the Oxygen Sensor Monitor and the Catalyst Monitor have been completed in the same drive cycle.

- If the MIL is ON and a DTC was set by the Fuel Monitor or Misfire Monitor (both continuous monitors), the vehicle must be operated in the Similar Condition Window for a specified amount of time.

- If the MIL is ON and a DTC was set by a Task Manager commanded once-per-trip monitor (such as the Oxygen Sensor Monitor, Catalyst Monitor, Purge Flow Monitor, Leak Detection Pump Monitor, EGR Monitor or Oxygen Sensor Heater Monitor), a good trip is when the monitor is passed on the next start-up.

- If the MIL is ON and any other emissions DTC was set (not an OBD II monitor), a good trip occurs when the Oxygen Sensor Monitor and Catalyst Monitor have been completed, or two minutes of engine run time if the Oxygen Sensor Monitor and Catalyst Monitor have been stopped from running.

Fuel System Good Trip

To count a good trip (three required) and turn off the MIL, the following conditions must occur:

- Engine in closed loop
- Operating in Similar Conditions Window
- Short Term multiplied by Long Term less than threshold
- Less than threshold for a predetermined time

If all of the previous criteria are met, the PCM will count a good trip (three required) and turn off the MIL.

Misfire Good Trip

If the following conditions are met the PCM will count one good trip (three required) in order to turn off the MIL:

- Operating in Similar Condition Window
- 1000 engine revolutions with no misfire

Warm-Up Cycles

Once the MIL has been extinguished by the Good Trip Counter, the PCM automatically switches to a Warm-Up Cycle Counter that can be viewed on the DRB III. Warm-Up Cycles are used to erase DTCs and Freeze Frames. Forty Warm-Up cycles must

DESCRIPTION AND OPERATION (Continued)

occur in order for the PCM to self-erase a DTC and Freeze Frame. A Warm-Up Cycle is defined as follows:

- Engine coolant temperature must start below and rise above 160° F
- Engine coolant temperature must rise by 40° F
- No further faults occur

Freeze Frame Data Storage

Once a failure occurs, the Task Manager records several engine operating conditions and stores it in a Freeze Frame. The Freeze Frame is considered one frame of information taken by an on-board data recorder. When a fault occurs, the PCM stores the input data from various sensors so that technicians can determine under what vehicle operating conditions the failure occurred.

The data stored in Freeze Frame is usually recorded when a system fails the first time for two trip faults. Freeze Frame data will only be overwritten by a different fault with a higher priority.

CAUTION: Erasing DTCs, either with the DRB III or by disconnecting the battery, also clears all Freeze Frame data.

Similar Conditions Window

The Similar Conditions Window displays information about engine operation during a monitor. Absolute MAP (engine load) and Engine RPM are stored in this window when a failure occurs. There are two different Similar conditions Windows: Fuel System and Misfire.

FUEL SYSTEM

- **Fuel System Similar Conditions Window** — An indicator that 'Absolute MAP When Fuel Sys Fail' and 'RPM When Fuel Sys Failed' are all in the same range when the failure occurred. Indicated by switching from 'NO' to 'YES'.

- **Absolute MAP When Fuel Sys Fail** — The stored MAP reading at the time of failure. Informs the user at what engine load the failure occurred.

- **Absolute MAP** — A live reading of engine load to aid the user in accessing the Similar Conditions Window.

- **RPM When Fuel Sys Fail** — The stored RPM reading at the time of failure. Informs the user at what engine RPM the failure occurred.

- **Engine RPM** — A live reading of engine RPM to aid the user in accessing the Similar Conditions Window.

- **Adaptive Memory Factor** — The PCM utilizes both Short Term Compensation and Long Term Adaptive to calculate the Adaptive Memory Factor for total fuel correction.

- **Upstream O₂S Volts** — A live reading of the Oxygen Sensor to indicate its performance. For example, stuck lean, stuck rich, etc.

- **SCW Time in Window (Similar Conditions Window Time in Window)** — A timer used by the PCM that indicates that, after all Similar Conditions have been met, if there has been enough good engine running time in the SCW without failure detected. This timer is used to increment a Good Trip.

- **Fuel System Good Trip Counter** — A Trip Counter used to turn OFF the MIL for Fuel System DTCs. To increment a Fuel System Good Trip, the engine must be in the Similar Conditions Window, Adaptive Memory Factor must be less than calibrated threshold and the Adaptive Memory Factor must stay below that threshold for a calibrated amount of time.

- **Test Done This Trip** — Indicates that the monitor has already been run and completed during the current trip.

MISFIRE

- **Same Misfire Warm-Up State** — Indicates if the misfire occurred when the engine was warmed up (above 160° F).

- **In Similar Misfire Window** — An indicator that 'Absolute MAP When Misfire Occurred' and 'RPM When Misfire Occurred' are all in the same range when the failure occurred. Indicated by switching from 'NO' to 'YES'.

- **Absolute MAP When Misfire Occurred** — The stored MAP reading at the time of failure. Informs the user at what engine load the failure occurred.

- **Absolute MAP** — A live reading of engine load to aid the user in accessing the Similar Conditions Window.

- **RPM When Misfire Occurred** — The stored RPM reading at the time of failure. Informs the user at what engine RPM the failure occurred.

- **Engine RPM** — A live reading of engine RPM to aid the user in accessing the Similar Conditions Window.

- **Adaptive Memory Factor** — The PCM utilizes both Short Term Compensation and Long Term Adaptive to calculate the Adaptive Memory Factor for total fuel correction.

- **200 Rev Counter** — Counts 0–100 720 degree cycles.

- **SCW Cat 200 Rev Counter** — Counts when in similar conditions.

- **SCW FTP 1000 Rev Counter** — Counts 0–4 when in similar conditions.

- **Misfire Good Trip Counter** — Counts up to three to turn OFF the MIL.

- **Misfire Data** — Data collected during test.

DESCRIPTION AND OPERATION (Continued)

- **Test Done This Trip** — Indicates YES when the test is done.

MONITORED SYSTEMS**OPERATION**

There are new electronic circuit monitors that check fuel, emission, engine and ignition performance. These monitors use information from various sensor circuits to indicate the overall operation of the fuel, engine, ignition and emission systems and thus the emissions performance of the vehicle.

The fuel, engine, ignition and emission systems monitors do not indicate a specific component problem. They do indicate that there is an implied problem within one of the systems and that a specific problem must be diagnosed.

If any of these monitors detect a problem affecting vehicle emissions, the Malfunction Indicator Lamp (MIL) will be illuminated. These monitors generate Diagnostic Trouble Codes that can be displayed with the MIL or a scan tool.

The following is a list of the system monitors:

- Misfire Monitor
- Fuel System Monitor
- Oxygen Sensor Monitor
- Oxygen Sensor Heater Monitor
- Catalyst Monitor
- Leak Detection Pump Monitor (if equipped)

All these system monitors require two consecutive trips with the malfunction present to set a fault.

Refer to the appropriate Powertrain Diagnostics Procedures manual for diagnostic procedures.

The following is an operation and description of each system monitor :

OXYGEN SENSOR (O2S) MONITOR

Effective control of exhaust emissions is achieved by an oxygen feedback system. The most important element of the feedback system is the O2S. The O2S is located in the exhaust path. Once it reaches operating temperature 300° to 350°C (572° to 662°F), the sensor generates a voltage that is inversely proportional to the amount of oxygen in the exhaust. The information obtained by the sensor is used to calculate the fuel injector pulse width. This maintains a 14.7 to 1 Air Fuel (A/F) ratio. At this mixture ratio, the catalyst works best to remove hydrocarbons (HC), carbon monoxide (CO) and nitrogen oxide (NOx) from the exhaust.

The O2S is also the main sensing element for the Catalyst and Fuel Monitors.

The O2S can fail in any or all of the following manners:

- slow response rate

- reduced output voltage
- dynamic shift
- shorted or open circuits

Response rate is the time required for the sensor to switch from lean to rich once it is exposed to a richer than optimum A/F mixture or vice versa. As the sensor starts malfunctioning, it could take longer to detect the changes in the oxygen content of the exhaust gas.

The output voltage of the O2S ranges from 0 to 1 volt. A good sensor can easily generate any output voltage in this range as it is exposed to different concentrations of oxygen. To detect a shift in the A/F mixture (lean or rich), the output voltage has to change beyond a threshold value. A malfunctioning sensor could have difficulty changing beyond the threshold value.

OXYGEN SENSOR HEATER MONITOR

If there is an oxygen sensor (O2S) shorted to voltage DTC, as well as a O2S heater DTC, the O2S fault **MUST** be repaired first. Before checking the O2S fault, verify that the heater circuit is operating correctly.

Effective control of exhaust emissions is achieved by an oxygen feedback system. The most important element of the feedback system is the O2S. The O2S is located in the exhaust path. Once it reaches operating temperature 300° to 350°C (572° to 662°F), the sensor generates a voltage that is inversely proportional to the amount of oxygen in the exhaust. The information obtained by the sensor is used to calculate the fuel injector pulse width. This maintains a 14.7 to 1 Air Fuel (A/F) ratio. At this mixture ratio, the catalyst works best to remove hydrocarbons (HC), carbon monoxide (CO) and nitrogen oxide (NOx) from the exhaust.

The voltage readings taken from the O2S sensor are very temperature sensitive. The readings are not accurate below 300°C. Heating of the O2S sensor is done to allow the engine controller to shift to closed loop control as soon as possible. The heating element used to heat the O2S sensor must be tested to ensure that it is heating the sensor properly.

The O2S sensor circuit is monitored for a drop in voltage. The sensor output is used to test the heater by isolating the effect of the heater element on the O2S sensor output voltage from the other effects.

LEAK DETECTION PUMP MONITOR (IF EQUIPPED)

The leak detection assembly incorporates two primary functions: it must detect a leak in the evaporative system and seal the evaporative system so the leak detection test can be run.

The primary components within the assembly are: A three port solenoid that activates both of the func-

DESCRIPTION AND OPERATION (Continued)

tions listed above; a pump which contains a switch, two check valves and a spring/diaphragm, a canister vent valve (CVV) seal which contains a spring loaded vent seal valve.

Immediately after a cold start, between predetermined temperature thresholds limits, the three port solenoid is briefly energized. This initializes the pump by drawing air into the pump cavity and also closes the vent seal. During non test conditions the vent seal is held open by the pump diaphragm assembly which pushes it open at the full travel position. The vent seal will remain closed while the pump is cycling due to the reed switch triggering of the three port solenoid that prevents the diaphragm assembly from reaching full travel. After the brief initialization period, the solenoid is de-energized allowing atmospheric pressure to enter the pump cavity, thus permitting the spring to drive the diaphragm which forces air out of the pump cavity and into the vent system. When the solenoid is energized and de energized, the cycle is repeated creating flow in typical diaphragm pump fashion. The pump is controlled in 2 modes:

Pump Mode: The pump is cycled at a fixed rate to achieve a rapid pressure build in order to shorten the overall test length.

Test Mode: The solenoid is energized with a fixed duration pulse. Subsequent fixed pulses occur when the diaphragm reaches the Switch closure point.

The spring in the pump is set so that the system will achieve an equalized pressure of about 7.5" H2O. The cycle rate of pump strokes is quite rapid as the system begins to pump up to this pressure. As the pressure increases, the cycle rate starts to drop off. If there is no leak in the system, the pump would eventually stop pumping at the equalized pressure. If there is a leak, it will continue to pump at a rate representative of the flow characteristic of the size of the leak. From this information we can determine if the leak is larger than the required detection limit (currently set at .040" orifice by CARB). If a leak is revealed during the leak test portion of the test, the test is terminated at the end of the test mode and no further system checks will be performed.

After passing the leak detection phase of the test, system pressure is maintained by turning on the LDP's solenoid until the purge system is activated. Purge activation in effect creates a leak. The cycle rate is again interrogated and when it increases due to the flow through the purge system, the leak check portion of the diagnostic is complete.

The canister vent valve will unseal the system after completion of the test sequence as the pump diaphragm assembly moves to the full travel position.

Evaporative system functionality will be verified by using the stricter evap purge flow monitor. At an

appropriate warm idle the LDP will be energized to seal the canister vent. The purge flow will be clocked up from some small value in an attempt to see a shift in the O2 control system. If fuel vapor, indicated by a shift in the O2 control, is present the test is passed. If not, it is assumed that the purge system is not functioning in some respect. The LDP is again turned off and the test is ended.

MISFIRE MONITOR

Excessive engine misfire results in increased catalyst temperature and causes an increase in HC emissions. Severe misfires could cause catalyst damage. To prevent catalytic convertor damage, the PCM monitors engine misfire.

The Powertrain Control Module (PCM) monitors for misfire during most engine operating conditions (positive torque) by looking at changes in the crankshaft speed. If a misfire occurs the speed of the crankshaft will vary more than normal.

FUEL SYSTEM MONITOR

To comply with clean air regulations, vehicles are equipped with catalytic converters. These converters reduce the emission of hydrocarbons, oxides of nitrogen and carbon monoxide. The catalyst works best when the Air Fuel (A/F) ratio is at or near the optimum of 14.7 to 1.

The PCM is programmed to maintain the optimum air/fuel ratio of 14.7 to 1. This is done by making short term corrections in the fuel injector pulse width based on the O2S sensor output. The programmed memory acts as a self calibration tool that the engine controller uses to compensate for variations in engine specifications, sensor tolerances and engine fatigue over the life span of the engine. By monitoring the actual fuel-air ratio with the O2S sensor (short term) and multiplying that with the program long-term (adaptive) memory and comparing that to the limit, it can be determined whether it will pass an emissions test. If a malfunction occurs such that the PCM cannot maintain the optimum A/F ratio, then the MIL will be illuminated.

CATALYST MONITOR

To comply with clean air regulations, vehicles are equipped with catalytic converters. These converters reduce the emission of hydrocarbons, oxides of nitrogen and carbon monoxide.

Normal vehicle miles or engine misfire can cause a catalyst to decay. A meltdown of the ceramic core can cause a reduction of the exhaust passage. This can increase vehicle emissions and deteriorate engine performance, driveability and fuel economy.

The catalyst monitor uses dual oxygen sensors (O2S's) to monitor the efficiency of the converter. The dual O2S's sensor strategy is based on the fact that

DESCRIPTION AND OPERATION (Continued)

as a catalyst deteriorates, its oxygen storage capacity and its efficiency are both reduced. By monitoring the oxygen storage capacity of a catalyst, its efficiency can be indirectly calculated. The upstream O₂S is used to detect the amount of oxygen in the exhaust gas before the gas enters the catalytic converter. The PCM calculates the A/F mixture from the output of the O₂S. A low voltage indicates high oxygen content (lean mixture). A high voltage indicates a low content of oxygen (rich mixture).

When the upstream O₂S detects a lean condition, there is an abundance of oxygen in the exhaust gas. A functioning converter would store this oxygen so it can use it for the oxidation of HC and CO. As the converter absorbs the oxygen, there will be a lack of oxygen downstream of the converter. The output of the downstream O₂S will indicate limited activity in this condition.

As the converter loses the ability to store oxygen, the condition can be detected from the behavior of the downstream O₂S. When the efficiency drops, no chemical reaction takes place. This means the concentration of oxygen will be the same downstream as upstream. The output voltage of the downstream O₂S copies the voltage of the upstream sensor. The only difference is a time lag (seen by the PCM) between the switching of the O₂S's.

To monitor the system, the number of lean-to-rich switches of upstream and downstream O₂S's is counted. The ratio of downstream switches to upstream switches is used to determine whether the catalyst is operating properly. An effective catalyst will have fewer downstream switches than it has upstream switches i.e., a ratio closer to zero. For a totally ineffective catalyst, this ratio will be one-to-one, indicating that no oxidation occurs in the device.

The system must be monitored so that when catalyst efficiency deteriorates and exhaust emissions increase to over the legal limit, the MIL will be illuminated.

TRIP DEFINITION

OPERATION

The term "Trip" has different meanings depending on what the circumstances are. If the MIL (Malfunction Indicator Lamp) is OFF, a Trip is defined as when the Oxygen Sensor Monitor and the Catalyst Monitor have been completed in the same drive cycle.

When any Emission DTC is set, the MIL on the dash is turned ON. When the MIL is ON, it takes 3 good trips to turn the MIL OFF. In this case, it depends on what type of DTC is set to know what a "Trip" is.

For the Fuel Monitor or Mis-Fire Monitor (continuous monitor), the vehicle must be operated in the

"Similar Condition Window" for a specified amount of time to be considered a Good Trip.

If a Non-Continuous OBDII Monitor, such as:

- Oxygen Sensor
- Catalyst Monitor
- Purge Flow Monitor
- Leak Detection Pump Monitor (if equipped)
- EGR Monitor (if equipped)
- Oxygen Sensor Heater Monitor

fails twice in a row and turns ON the MIL, re-running that monitor which previously failed, on the next start-up and passing the monitor is considered to be a Good Trip.

If any other Emission DTC is set (not an OBDII Monitor), a Good Trip is considered to be when the Oxygen Sensor Monitor and Catalyst Monitor have been completed; or 2 Minutes of engine run time if the Oxygen Sensor Monitor or Catalyst Monitor have been stopped from running.

It can take up to 2 Failures in a row to turn on the MIL. After the MIL is ON, it takes 3 Good Trips to turn the MIL OFF. After the MIL is OFF, the PCM will self-erase the DTC after 40 Warm-up cycles. A Warm-up cycle is counted when the ECT (Engine Coolant Temperature Sensor) has crossed 160°F and has risen by at least 40°F since the engine has been started.

COMPONENT MONITORS

OPERATION

There are several components that will affect vehicle emissions if they malfunction. If one of these components malfunctions the Malfunction Indicator Lamp (MIL) will illuminate.

Some of the component monitors are checking for proper operation of the part. Electrically operated components now have input (rationality) and output (functionality) checks. Previously, a component like the Throttle Position sensor (TPS) was checked by the PCM for an open or shorted circuit. If one of these conditions occurred, a DTC was set. Now there is a check to ensure that the component is working. This is done by watching for a TPS indication of a greater or lesser throttle opening than MAP and engine rpm indicate. In the case of the TPS, if engine vacuum is high and engine rpm is 1600 or greater and the TPS indicates a large throttle opening, a DTC will be set. The same applies to low vacuum if the TPS indicates a small throttle opening.

All open/short circuit checks or any component that has an associated limp in will set a fault after 1 trip with the malfunction present. Components without an associated limp in will take two trips to illuminate the MIL.

DESCRIPTION AND OPERATION (Continued)

Refer to the Diagnostic Trouble Codes Description Charts in this section and the appropriate Powertrain Diagnostic Procedure Manual for diagnostic procedures.

NON-MONITORED CIRCUITS

The PCM does not monitor the following circuits, systems and conditions that could have malfunctions causing driveability problems. The PCM might not store diagnostic trouble codes for these conditions. However, problems with these systems may cause the PCM to store diagnostic trouble codes for other systems or components. For example, a fuel pressure problem will not register a fault directly, but could cause a rich/lean condition or misfire. This could cause the PCM to store an oxygen sensor or misfire diagnostic trouble code.

OPERATION**FUEL PRESSURE**

The fuel pressure regulator controls fuel system pressure. The PCM cannot detect a clogged fuel pump inlet filter, clogged in-line fuel filter, or a pinched fuel supply or return line. However, these could result in a rich or lean condition causing the PCM to store an oxygen sensor or fuel system diagnostic trouble code.

SECONDARY IGNITION CIRCUIT

The PCM cannot detect an inoperative ignition coil, fouled or worn spark plugs, ignition cross firing, or open spark plug cables.

CYLINDER COMPRESSION

The PCM cannot detect uneven, low, or high engine cylinder compression.

EXHAUST SYSTEM

The PCM cannot detect a plugged, restricted or leaking exhaust system, although it may set a fuel system fault.

FUEL INJECTOR MECHANICAL MALFUNCTIONS

The PCM cannot determine if a fuel injector is clogged, the needle is sticking or if the wrong injector is installed. However, these could result in a rich or lean condition causing the PCM to store a diagnostic trouble code for either misfire, an oxygen sensor, or the fuel system.

EXCESSIVE OIL CONSUMPTION

Although the PCM monitors engine exhaust oxygen content when the system is in closed loop, it cannot determine excessive oil consumption.

THROTTLE BODY AIR FLOW

The PCM cannot detect a clogged or restricted air cleaner inlet or filter element.

VACUUM ASSIST

The PCM cannot detect leaks or restrictions in the vacuum circuits of vacuum assisted engine control system devices. However, these could cause the PCM to store a MAP sensor diagnostic trouble code and cause a high idle condition.

PCM SYSTEM GROUND

The PCM cannot determine a poor system ground. However, one or more diagnostic trouble codes may be generated as a result of this condition. The module should be mounted to the body at all times, also during diagnostic.

PCM CONNECTOR ENGAGEMENT

The PCM may not be able to determine spread or damaged connector pins. However, it might store diagnostic trouble codes as a result of spread connector pins.

HIGH AND LOW LIMITS**OPERATION**

The PCM compares input signal voltages from each input device with established high and low limits for the device. If the input voltage is not within limits and other criteria are met, the PCM stores a diagnostic trouble code in memory. Other diagnostic trouble code criteria might include engine RPM limits or input voltages from other sensors or switches that must be present before verifying a diagnostic trouble code condition.

LOAD VALUE**OPERATION**

ENGINE	IDLE/NEUTRAL	2500 RPM/ NEUTRAL
All Engines	2% to 8% of Maximum Load	9% to 17% of Maximum Load

EVAPORATIVE EMISSION CONTROLS

TABLE OF CONTENTS

	page		page
DESCRIPTION AND OPERATION		LEAK DETECTION PUMP (LDP) 27	
EVAPORATION CONTROL SYSTEM	23	CRANKCASE VENTILATION SYSTEM 27	
ROLLOVER VALVE	23	REMOVAL AND INSTALLATION	
EVAP CANISTER	24	EVAP CANISTER..... 27	
DUTY CYCLE EVAP CANISTER PURGE		DUTY CYCLE EVAP CANISTER PURGE	
SOLENOID	24	SOLENOID	
SOLENOID	24	SOLENOID	
LEAK DETECTION PUMP (LDP).....	24	ROLLOVER VALVE(S)	
CRANKCASE VENTILATION SYSTEM	25	LEAK DETECTION PUMP (LDP)..... 28	
VEHICLE EMISSION CONTROL		SPECIFICATIONS	
INFORMATION (VECI) LABEL.....	26	TORQUE CHART..... 28	
DIAGNOSIS AND TESTING			
VACUUM SCHEMATICS.....	26		

DESCRIPTION AND OPERATION

EVAPORATION CONTROL SYSTEM

OPERATION

The evaporation control system prevents the emission of fuel tank vapors into the atmosphere. When fuel evaporates in the fuel tank, the vapors pass through vent hoses or tubes to a charcoal filled evaporative canister. The canister temporarily holds the vapors. The Powertrain Control Module (PCM) allows intake manifold vacuum to draw vapors into the combustion chambers during certain operating conditions.

All engines use a duty cycle purge system. The PCM controls vapor flow by operating the duty cycle EVAP purge solenoid. Refer to Duty Cycle EVAP Canister Purge Solenoid.

When equipped with certain emissions packages, a Leak Detection Pump (LDP) will be used as part of the evaporative system for OBD II requirements. Also refer to Leak Detection Pump.

NOTE: The evaporative system uses specially manufactured lines/hoses. If replacement becomes necessary, only use fuel resistant hose.

ROLLOVER VALVE

DESCRIPTION

The fuel tank is equipped with a rollover valve. The valve is located on the top of the fuel tank (Fig. 1).

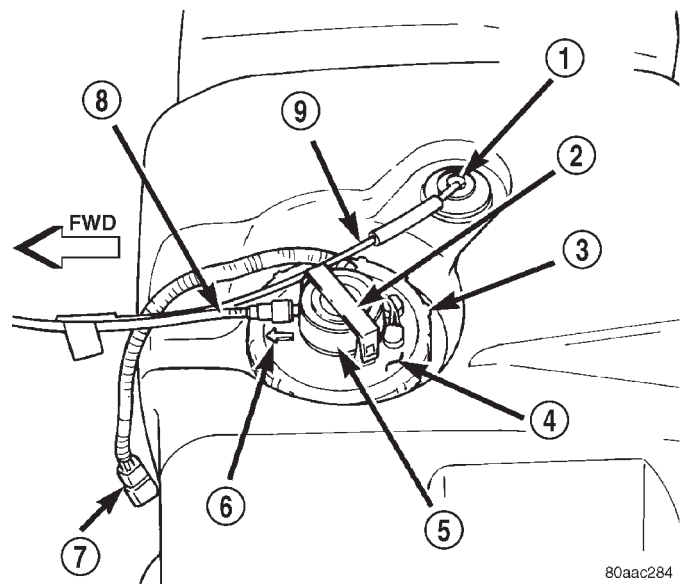

Fig. 1 Rollover Valve Location

- 1 - ROLLOVER VALVE
- 2 - RETAINER CLAMP
- 3 - LOCKNUT
- 4 - FUEL PUMP MODULE
- 5 - FUEL FILTER/FUEL PRESSURE REGULATOR
- 6 - ALIGNMENT ARROW
- 7 - PIGTAIL HARNESS
- 8 - FUEL SUPPLY TUBE
- 9 - EVAP CANISTER VENT LINE

OPERATION

The rollover valve will prevent fuel flow through the fuel tank vent (EVAP) hoses in the event of an accidental vehicle rollover. The EVAP canister draws fuel vapors from the fuel tank through this valve.

DESCRIPTION AND OPERATION (Continued)

The valve cannot be serviced separately. If replacement is necessary, the fuel tank must be replaced.

EVAP CANISTER

DESCRIPTION

A maintenance free, EVAP canister is used on all vehicles. The EVAP canister is located under the left side of vehicle near the front of the rear axle (Fig. 2).

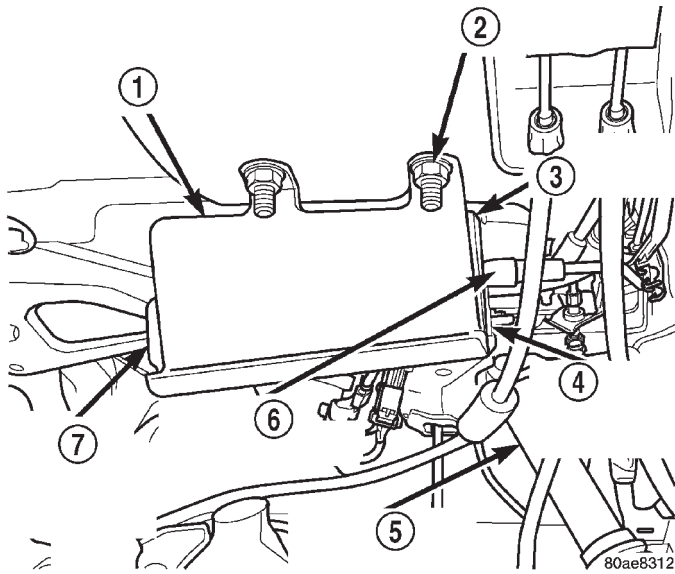

Fig. 2 EVAP Canister Location

- 1 - CANISTER MOUNTING BRACKET
- 2 - BRACKET NUTS (3)
- 3 - EVAP CANISTER
- 4 - CANISTER MOUNTING NUTS (2)
- 5 - L. R. SHOCK ABSORBER
- 6 - EVAP LINES/HOSES
- 7 - DOWEL PINS AND BUSHINGS (2)

OPERATION

The EVAP canister is filled with granules of an activated carbon mixture. Fuel vapors entering the EVAP canister are absorbed by the charcoal granules.

Fuel tank pressure vents into the EVAP canister. Fuel vapors are temporarily held in the canister until they can be drawn into the intake manifold. The duty cycle EVAP canister purge solenoid allows the EVAP canister to be purged at predetermined times and at certain engine operating conditions.

DUTY CYCLE EVAP CANISTER PURGE SOLENOID

OPERATION

The duty cycle EVAP canister purge solenoid (DCP) regulates the rate of vapor flow from the EVAP canister to the intake manifold. The Powertrain Control Module (PCM) operates the solenoid.

During the cold start warm-up period and the hot start time delay, the PCM does not energize the solenoid. When de-energized, no vapors are purged. The PCM de-energizes the solenoid during open loop operation.

The engine enters closed loop operation after it reaches a specified temperature and the time delay ends. During closed loop operation, the PCM cycles (energizes and de-energizes) the solenoid 5 or 10 times per second, depending upon operating conditions. The PCM varies the vapor flow rate by changing solenoid pulse width. Pulse width is the amount of time that the solenoid is energized. The PCM adjusts solenoid pulse width based on engine operating condition.

LEAK DETECTION PUMP (LDP)

OPERATION

The Leak Detection Pump (LDP) is used only with certain emission packages.

The LDP is a device used to detect a leak in the evaporative system.

The pump contains a 3 port solenoid, a pump that contains a switch, a spring loaded canister vent valve seal, 2 check valves and a spring/diaphragm.

Immediately after a cold start, engine temperature between 40°F and 86°F, the 3 port solenoid is briefly energized. This initializes the pump by drawing air into the pump cavity and also closes the vent seal. During non-test conditions, the vent seal is held open by the pump diaphragm assembly which pushes it open at the full travel position. The vent seal will remain closed while the pump is cycling. This is due to the operation of the 3 port solenoid which prevents the diaphragm assembly from reaching full travel. After the brief initialization period, the solenoid is de-energized, allowing atmospheric pressure to enter the pump cavity. This permits the spring to drive the diaphragm which forces air out of the pump cavity and into the vent system. When the solenoid is energized and de-energized, the cycle is repeated creating flow in typical diaphragm pump fashion. The pump is controlled in 2 modes:

PUMP MODE: The pump is cycled at a fixed rate to achieve a rapid pressure build in order to shorten the overall test time.

TEST MODE: The solenoid is energized with a fixed duration pulse. Subsequent fixed pulses occur when the diaphragm reaches the switch closure point.

The spring in the pump is set so that the system will achieve an equalized pressure of about 7.5 inches of water.

When the pump starts, the cycle rate is quite high. As the system becomes pressurized pump rate drops.

DESCRIPTION AND OPERATION (Continued)

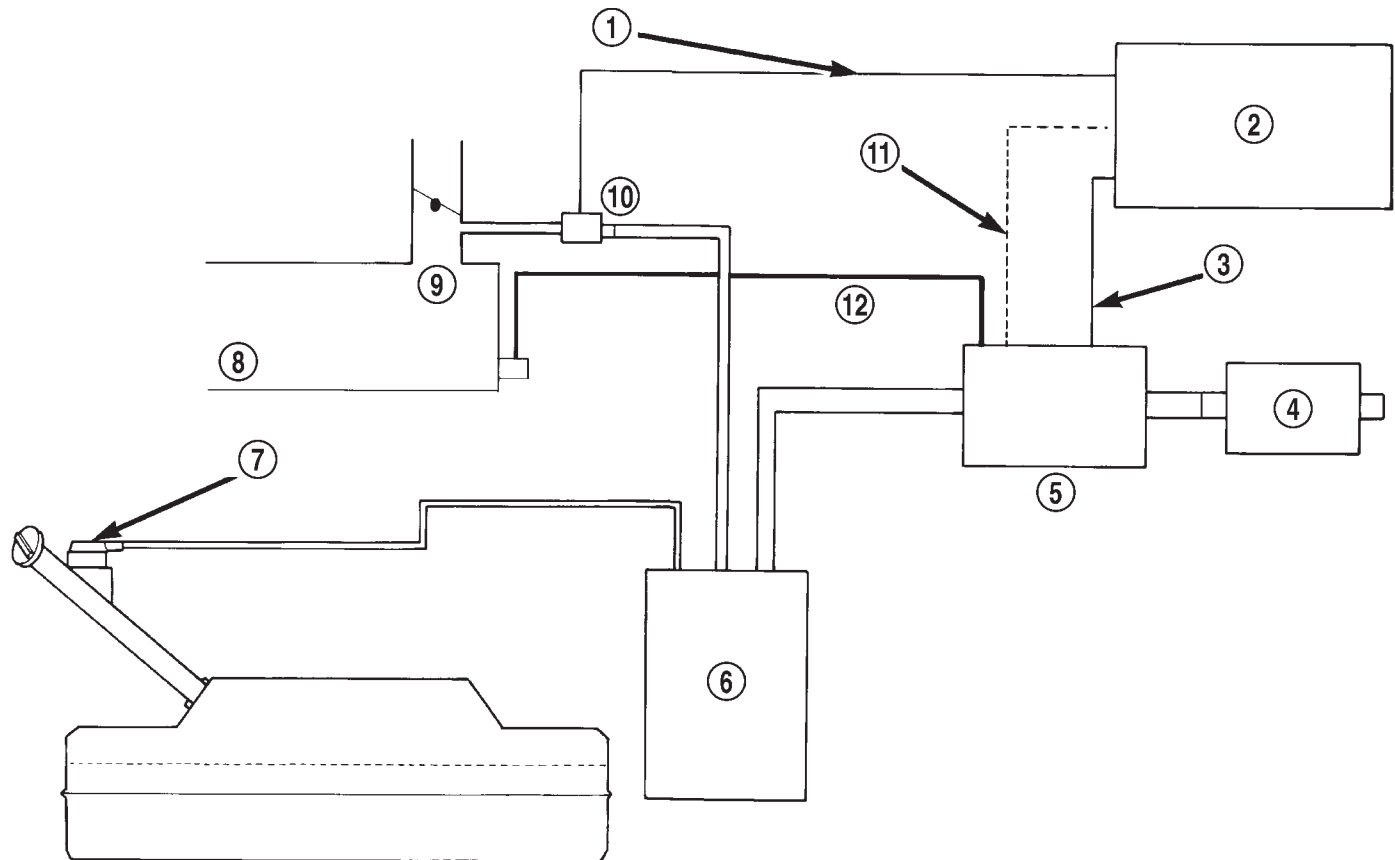

80004293

Fig. 3 Evaporative System Monitor Schematic—Typical

- | | |
|--|--|
| 1 - DUTY CYCLE PURGE SOLENOID (DCPS) DRIVER | 7 - TANK ROLLOVER VALVE & VAPOR FLOW CONTROL ORIFICE |
| 2 - POWERTRAIN CONTROL MODULE (PCM) | 8 - INTAKE MANIFOLD |
| 3 - 3-PORT SOLENOID DRIVER | 9 - THROTTLE BODY |
| 4 - REMOTE FILTER | 10 - DCPS |
| 5 - COMBINED CANISTER VENT VALVE & LEAK DETECTION PUMP | 11 - SWITCH SIGNAL INPUT TO THE PCM |
| 6 - CANISTER | 12 - ENGINE VACUUM LINE |

If there is no leak the pump will quit. If there is a leak, the test is terminated at the end of the test mode.

If there is no leak, the purge monitor is run. If the cycle rate increases due to the flow through the purge system, the test is passed and the diagnostic is complete.

The canister vent valve will unseal the system after completion of the test sequence as the pump diaphragm assembly moves to the full travel position.

A typical system schematic is shown in (Fig. 3).

CRANKCASE VENTILATION SYSTEM

DESCRIPTION

All 2.5L 4-cylinder and 4.0L 6-cylinder engines are equipped with a Closed Crankcase Ventilation (CCV) system (Fig. 4) or (Fig. 5).

OPERATION

The CCV system performs the same function as a conventional PCV system, but does not use a vacuum controlled valve.

On 4.0L 6 cylinder engines, a molded vacuum tube connects manifold vacuum to top of cylinder head (valve) cover at dash panel end. The vacuum fitting contains a fixed orifice of a calibrated size. It meters the amount of crankcase vapors drawn out of the engine.

On 2.5L 4 cylinder engines, a fitting on drivers side of cylinder head (valve) cover contains the metered orifice. It is connected to manifold vacuum.

A fresh air supply hose from the air cleaner is connected to front of cylinder head cover on 4.0L engines. It is connected to rear of cover on 2.5L engines.

DESCRIPTION AND OPERATION (Continued)

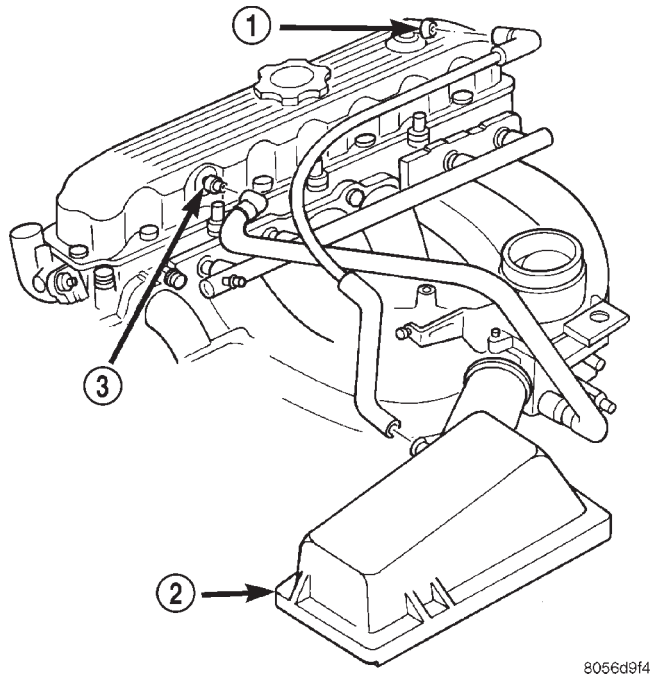

8056d9f4

Fig. 4 CCV System—2.5L Engine—Typical

- 1 - AIR INLET FITTING
- 2 - AIR FILTER COVER
- 3 - FIXED ORIFICE FITTING

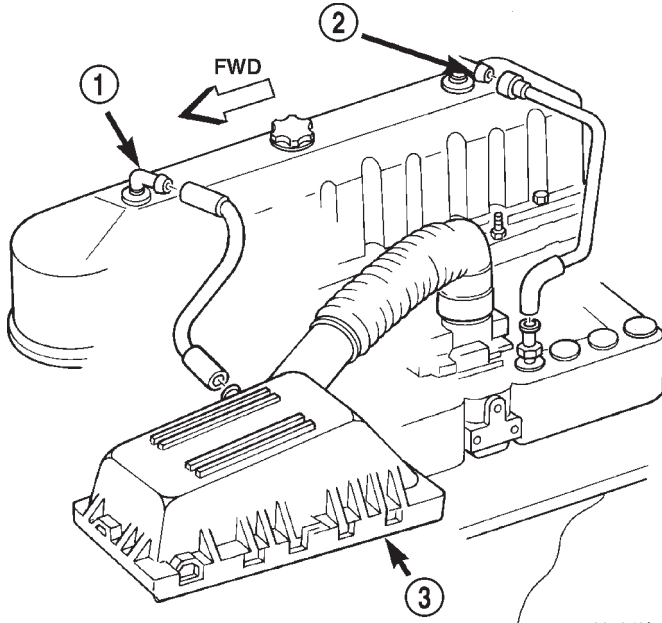

8056d9f5

Fig. 5 CCV System—4.0L Engine—Typical

- 1 - AIR INLET FITTING
- 2 - FIXED ORIFICE FITTING
- 3 - AIR FILTER COVER

When the engine is operating, fresh air enters the engine and mixes with crankcase vapors. Manifold vacuum draws the vapor/air mixture through the

fixed orifice and into the intake manifold. The vapors are then consumed during combustion.

VEHICLE EMISSION CONTROL INFORMATION (VECI) LABEL**DESCRIPTION**

All vehicles are equipped with a combined VECI label. This label is located in the engine compartment (Fig. 6).

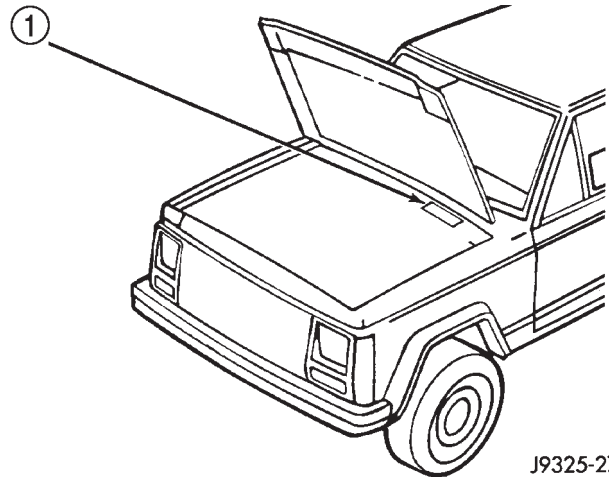

J9325-27

Fig. 6 VECI Label Location—Typical

- 1 - VECI LABEL

OPERATION

The VECI label contains the following:

- Engine family and displacement
- Evaporative family
- Emission control system schematic
- Certification application
- Engine timing specifications (if adjustable)
- Idle speeds (if adjustable)
- Spark plug and gap

The label also contains an engine vacuum schematic. There are unique labels for vehicles built for sale in the state of California and the country of Canada. Canadian labels are written in both the English and French languages. These labels are permanently attached and cannot be removed without defacing information and destroying label.

DIAGNOSIS AND TESTING**VACUUM SCHEMATICS**

A vacuum schematic for emission related items can be found on the Vehicle Emission Control Information (VECI) label. For label location, refer to Vehicle Emission Control Information (VECI) Label.

DIAGNOSIS AND TESTING (Continued)

LEAK DETECTION PUMP (LDP)

Refer to the appropriate Powertrain Diagnostic Procedures service manual for LDP testing procedures.

CRANKCASE VENTILATION SYSTEM

TESTING/CLEANING

The Crankcase Ventilation (CCV) system performs the same function as a conventional PCV system, but does not use a vacuum controlled valve. A vacuum fitting containing a fixed orifice of a calibrated size is used. It meters the amount of crankcase vapors drawn out of the engine.

- (1) Check each CCV system tube (line) for leaks, cracks, kinks or bends. Replace as necessary
- (2) Disconnect each CCV tube..
- (3) Blow compressed air through each tube and check for blockage or restrictions. If cleaning is necessary, spray a soapy-type all-purpose cleaner into each component and blow out. After restriction is cleared, rinse out component with clear water. Blow water from component and install to vehicle. **To prevent damage to plastic components, never spray carburetor-type cleaner into any of the plastic tubes or the fixed orifice fitting. Never attempt to clean the fixed orifice fitting with a metal object as calibration could be affected. If fixed fitting cannot be cleared, replace it.**

REMOVAL AND INSTALLATION

EVAP CANISTER

The EVAP canister is located under left side of vehicle near front of rear axle (Fig. 7).

REMOVAL

- (1) Disconnect vacuum hoses/lines at EVAP canister. Note location of lines before removal.
- (2) Remove EVAP canister and mounting bracket assembly from body (3 nuts).
- (3) Remove canister from mounting bracket (2 nuts).

INSTALLATION

- (1) Position canister into canister mounting bracket. Align 2 canister dowel pins into rubber bushings.
- (2) Install 2 canister nuts and tighten to 5 N·m (45 in. lbs.) torque.
- (3) Position canister and bracket assembly to body.
- (4) Install 3 nuts and tighten to 43 N·m (32 ft. lbs.) torque.
- (5) Connect vacuum hoses/lines at EVAP canister.

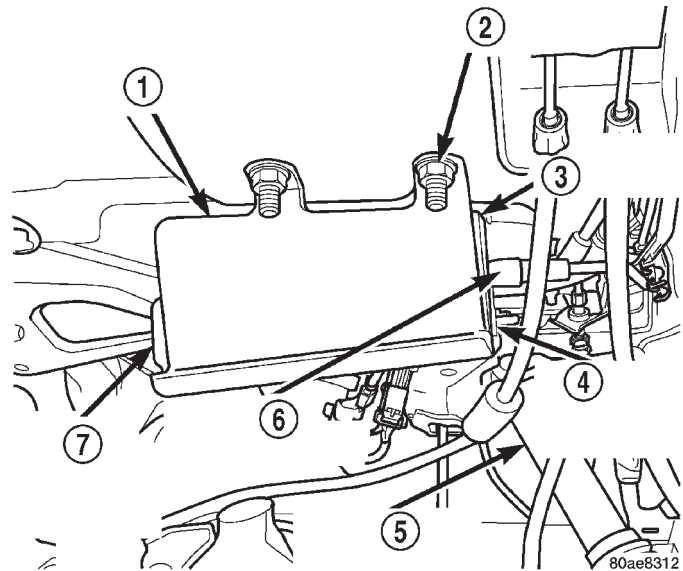

Fig. 7 EVAP Canister Location

- 1 - CANISTER MOUNTING BRACKET
- 2 - BRACKET NUTS (3)
- 3 - EVAP CANISTER
- 4 - CANISTER MOUNTING NUTS (2)
- 5 - L. R. SHOCK ABSORBER
- 6 - EVAP LINES/HOSES
- 7 - DOWEL PINS AND BUSHINGS (2)

DUTY CYCLE EVAP CANISTER PURGE SOLENOID

REMOVAL

The solenoid attaches to a bracket located in right-rear side of engine compartment (Fig. 8) or (Fig. 9). The top of the solenoid has the word UP or TOP on it. The solenoid will not operate properly unless it is installed correctly.

- (1) Disconnect electrical wiring connector at solenoid.
- (2) Disconnect vacuum harness at solenoid.
- (3) Remove solenoid and its support bracket.

INSTALLATION

- (1) Install EVAP canister purge solenoid and its mounting bracket to cowl panel.
- (2) Tighten bolt to 5 N·m (45 in. lbs.) torque.
- (3) Connect vacuum harness and wiring connector.

ROLLOVER VALVE(S)

The rollover valve(s) are/is molded into the fuel tank and are not serviced separately. If replacement is necessary, the fuel tank must be replaced. Refer to Fuel Tank Removal/Installation.

REMOVAL AND INSTALLATION (Continued)

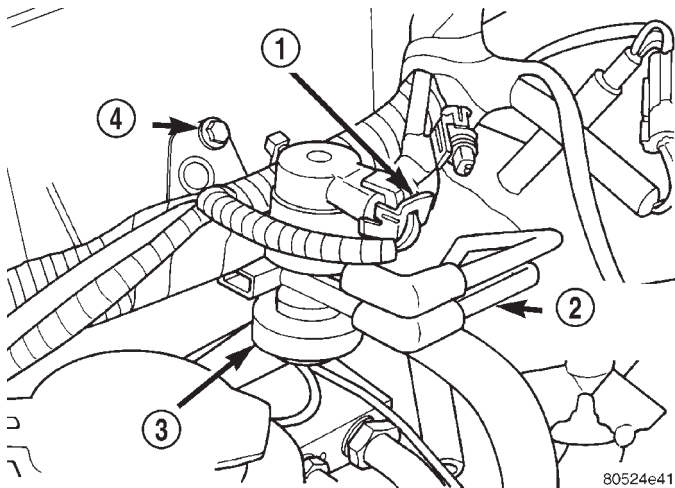

Fig. 8 EVAP Canister Purge Solenoid (Without LDP)

- 1 - ELECTRICAL CONNECTOR
- 2 - VACUUM HARNESS
- 3 - PURGE SOLENOID
- 4 - MOUNTING BOLT

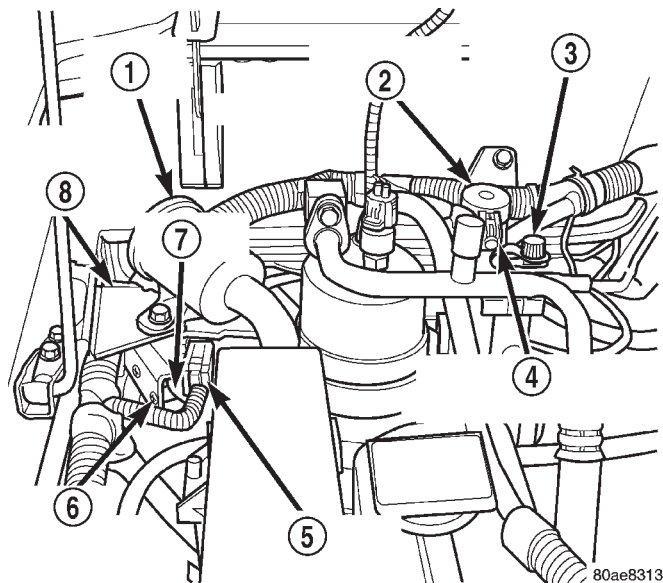

Fig. 9 EVAP Canister Purge Solenoid (With LDP)

- 1 - LDP FILTER
- 2 - EVAP SOLENOID
- 3 - EVAP SYSTEM TEST PORT
- 4 - EVAP SOLENOID ELEC. CONNECTOR
- 5 - LDP ELEC. CONNECTOR
- 6 - LDP MOUNTING SCREWS (2)
- 7 - LDP
- 8 - LDP MOUNTING BRACKET

LEAK DETECTION PUMP (LDP)

The LDP is located in the right-rear side of engine compartment (Fig. 9). The LDP filter is located above the LDP (Fig. 9). The LDP and LDP filter are replaced (serviced) as one unit.

REMOVAL

- (1) Carefully remove hose at LDP filter.
- (2) Remove LDP filter mounting bolt and remove from vehicle.
- (3) Carefully remove vapor/vacuum lines at LDP.
- (4) Disconnect electrical connector at LDP.
- (5) Remove 2 LDP mounting screws (Fig. 9) and remove from vehicle.

INSTALLATION

- (1) Install LDP to mounting bracket. Tighten screws to 1 N·m (11 in. lbs.) torque.
- (2) Install LDP filter to mounting bracket. Tighten bolt to 7 N·m (65 in. lbs.) torque.
- (3) Carefully install vapor/vacuum lines to LDP, and install hose to LDP filter. **The vapor/vacuum lines and hoses must be firmly connected. Check the vapor/vacuum lines at the LDP, LDP filter and EVAP canister purge solenoid for damage or leaks. If a leak is present, a Diagnostic Trouble Code (DTC) may be set.**
- (4) Connect electrical connector to LDP.

SPECIFICATIONS

TORQUE CHART

Description	Torque
EVAP Canister Mounting Nuts (canister-to-mounting bracket)	5 N·m (45 in. lbs.)
EVAP Canister Mounting Bracket Nuts (mounting bracket-to-body)	43 N·m (32 in. lbs.)
EVAP Canister Purge Solenoid Bracket-to-Body Mounting Bolt	5 N·m (45 in. lbs.)
LDP Mounting Screws	1 N·m (11 in. lbs.)