

CLUTCH

TABLE OF CONTENTS

| | page | | page |
|---|------|---|------|
| DESCRIPTION AND OPERATION | | CLUTCH FLYWHEEL RUNOUT | 6 |
| CLUTCH | 1 | CLUTCH COVER AND DISC RUNOUT | 7 |
| FLYWHEEL | 2 | CLUTCH DIAGNOSIS CHARTS | 7 |
| CLUTCH DISC | 2 | SERVICE PROCEDURES | |
| CLUTCH PRESSURE PLATE | 2 | CLUTCH COMPONENT LUBRICATION | 9 |
| CLUTCH RELEASE BEARING | 3 | CLUTCH LINKAGE FLUID | 9 |
| HYDRAULIC CLUTCH LINKAGE | 4 | CLUTCH FLUID LEVEL | 10 |
| DIAGNOSIS AND TESTING | | FLYWHEEL | 10 |
| SAFETY PRECAUTIONS | 4 | REMOVAL AND INSTALLATION | |
| INSTALLATION METHODS AND PARTS | | CLUTCH COVER AND DISC | 11 |
| USAGE | 4 | RELEASE BEARING | 12 |
| CLUTCH DIAGNOSTIC INFORMATION | 4 | PILOT BEARING | 12 |
| CLUTCH CONTAMINATION | 6 | CLUTCH HOUSING | 13 |
| IMPROPER CLUTCH RELEASE OR | | CLUTCH HYDRAULIC LINKAGE | 13 |
| ENGAGEMENT | 6 | SPECIFICATIONS | |
| CLUTCH MISALIGNMENT | 6 | TORQUE | 15 |
| CLUTCH HOUSING MISALIGNMENT | 6 | | |

DESCRIPTION AND OPERATION

CLUTCH

DESCRIPTION

The clutch mechanism consists of a flywheel, a single, dry-type disc, and a diaphragm style clutch cover (Fig. 1). A hydraulic linkage is used to operate the clutch release bearing and fork. The flywheel is bolted to the rear flange of the crankshaft. The clutch pressure plate is bolted to the flywheel with the clutch disc located between these two components. The clutch system provides the mechanical, but still easily detachable, link between the engine and the transmission. The system is designed to ensure that the full torque output of the engine is transferred to the transmission while isolating the transmission from the engine firing pulses to minimize concerns such as gear rattle.

OPERATION

Leverage, clamping force, and friction are what make the clutch work. The disc serves as the friction element and a diaphragm spring and pressure plate provide the clamping force. The clutch pedal, hydraulic linkage, release lever and bearing provide the leverage.

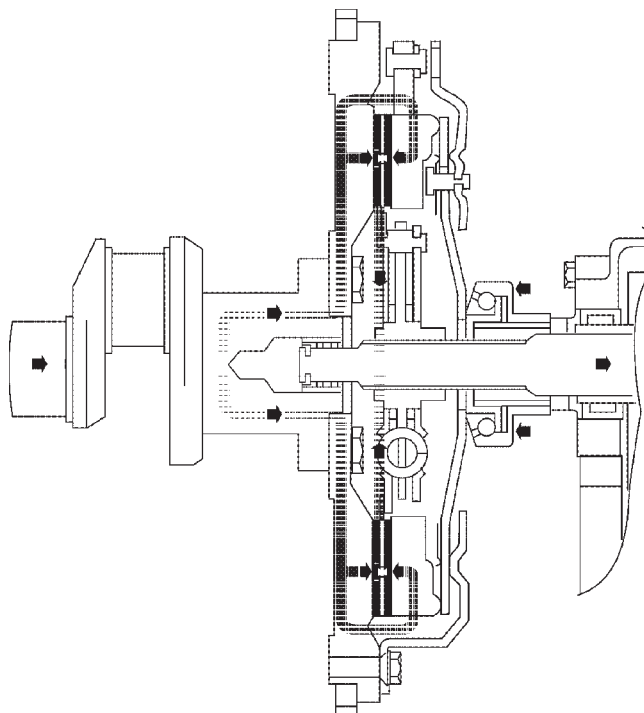

80be45e9

Fig. 1 Engine Powerflow

DESCRIPTION AND OPERATION (Continued)

The clutch master cylinder push rod is connected to the clutch pedal. When the clutch pedal is depressed, the slave cylinder is operated by the clutch master cylinder mounted on the dash panel. The release fork is actuated by the hydraulic slave cylinder mounted on the transmission housing. The release bearing is operated by a release fork pivoting on a ball stud mounted in the transmission housing. The release bearing then depresses the pressure plate spring fingers, thereby releasing pressure on the clutch disc and allowing the engine crankshaft to spin independently of the transmission input shaft (Fig. 2).

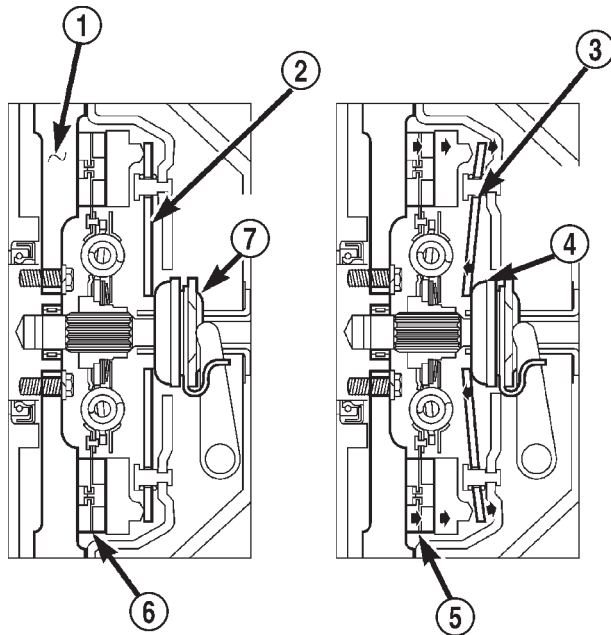

Fig. 2 Clutch Operation

- 1 - FLYWHEEL
- 2 - PRESSURE PLATE FINGERS
- 3 - PIVOT POINT
- 4 - RELEASE BEARING PUSHED IN
- 5 - CLUTCH DISC ENGAGED
- 6 - CLUTCH DISC ENGAGED
- 7 - RELEASE BEARING

FLYWHEEL

DESCRIPTION

The flywheel (Fig. 3) is a heavy plate bolted to the rear of the crankshaft. The flywheel incorporates the ring gear around the outer circumference to mesh with the starter to permit engine cranking. The rear face of the flywheel serves as the driving member to the clutch disc.

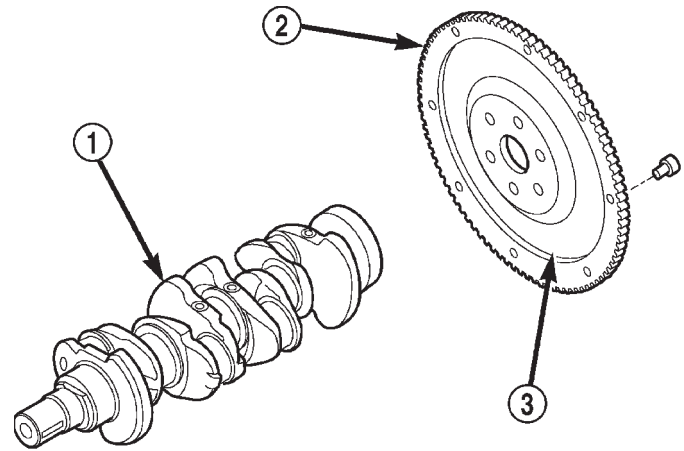

Fig. 3 Flywheel

80be45ee

- 1 - CRANKSHAFT
- 2 - RING GEAR
- 3 - FLYWHEEL

OPERATION

The flywheel serves to dampen the engine firing pulses. The heavy weight of the flywheel relative to the rotating mass of the engine components serves to stabilize the flow of power to the remainder of the drivetrain. The crankshaft has the tendency to attempt to speed up and slow down in response to the cylinder firing pulses. The flywheel dampens these impulses by absorbing energy when the crankshaft speeds and releasing the energy back into the system when the crankshaft slows down.

CLUTCH DISC

DESCRIPTION

The clutch disc friction material is riveted to the disc hub (Fig. 4). The hub bore is splined for installation on the transmission input shaft. The clutch disc has cushion springs in the disc hub to dampen disc vibrations during application and release of the clutch.

OPERATION

The clutch disc is held onto the surface of the flywheel by the force exerted by the pressure plate's diaphragm spring. The friction material of the clutch disc then transfers the engine torque from the flywheel and pressure plate to the input shaft of the transmission.

CLUTCH PRESSURE PLATE

DESCRIPTION

The clutch pressure plate assembly is a diaphragm type with a one-piece spring and multiple release fingers (Fig. 5). The pressure plate release fingers are preset during manufacture and are not adjustable. The assembly also contains the cover, pressure plate, and fulcrum components.

DESCRIPTION AND OPERATION (Continued)

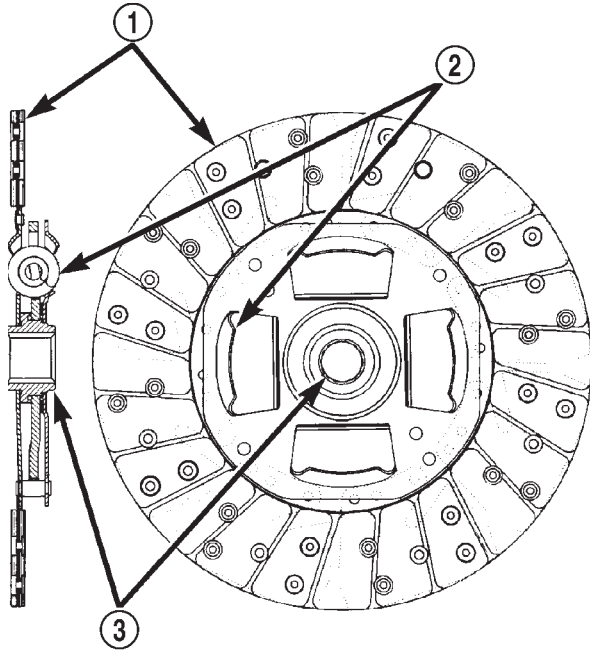

80be45eb

Fig. 4 Clutch Disc-Typical

- 1 - FACING MATERIAL
- 2 - DAMPER SPRINGS
- 3 - HUB

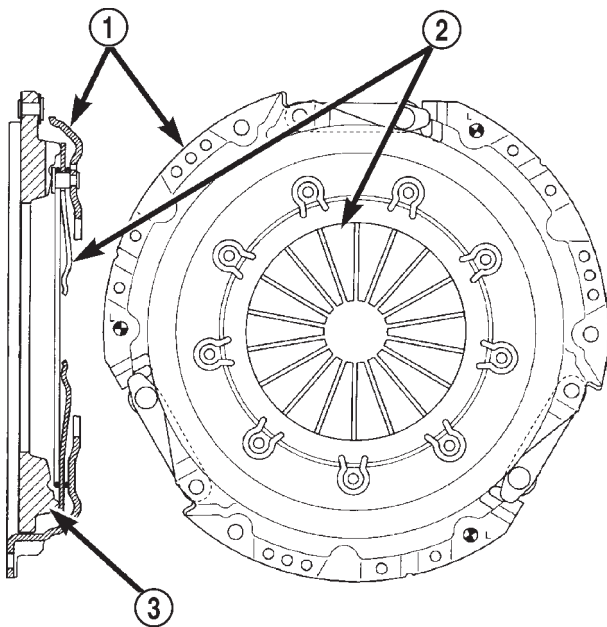

80be45ec

Fig. 5 Clutch Pressure Plate-Typical

- 1 - COVER
- 2 - RELEASE FINGERS
- 3 - PRESSURE PLATE

OPERATION

The clutch pressure plate assembly clamps the clutch disc against the flywheel. When the release bearing is depressed by the shift fork, the pressure exerted on the clutch disc by the pressure plate spring is decreased. As additional force is applied, the bearing presses the diaphragm spring fingers inward on the fulcrums. This action moves the pressure plate rearward relieving clamp force on the disc. The clutch disc is disengaged and freewheeling at this point.

CLUTCH RELEASE BEARING

DESCRIPTION

A conventional release bearing (Fig. 6) is used to engage and disengage the clutch pressure plate assembly. The clutch release bearing is mounted on the transmission front bearing retainer. The bearing is attached to the release fork, which moves the bearing into contact with the clutch cover diaphragm spring.

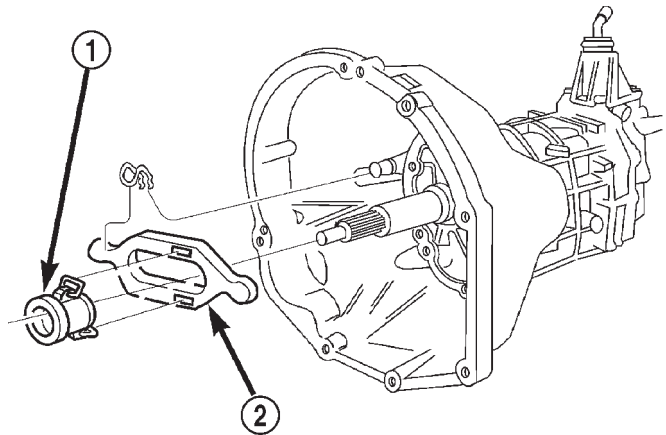

80be45ed

Fig. 6 Clutch Release Bearing

- 1 - RELEASE BEARING
- 2 - RELEASE FORK

OPERATION

The release bearing is operated by a release fork in the clutch housing. Slave cylinder force causes the release lever to move the release bearing into contact with the diaphragm spring. As additional force is applied, the bearing presses the diaphragm spring fingers inward on the fulcrums. This action moves the pressure plate rearward relieving clamp force on the disc. Releasing pedal pressure removes clutch hydraulic pressure. The release bearing then moves away from the diaphragm spring which allows the pressure plate to exert clamping force on the clutch disc.

DESCRIPTION AND OPERATION (Continued)

HYDRAULIC CLUTCH LINKAGE

DESCRIPTION

The hydraulic linkage consists of a clutch master cylinder with integral reservoir, a clutch slave cylinder and an interconnecting fluid line (Fig. 7).

The clutch master cylinder push rod is connected to the clutch pedal. The slave cylinder push rod is connected to the clutch release fork. The master cylinder is mounted on the driver side of the dash panel adjacent to the brake master cylinder and booster assembly.

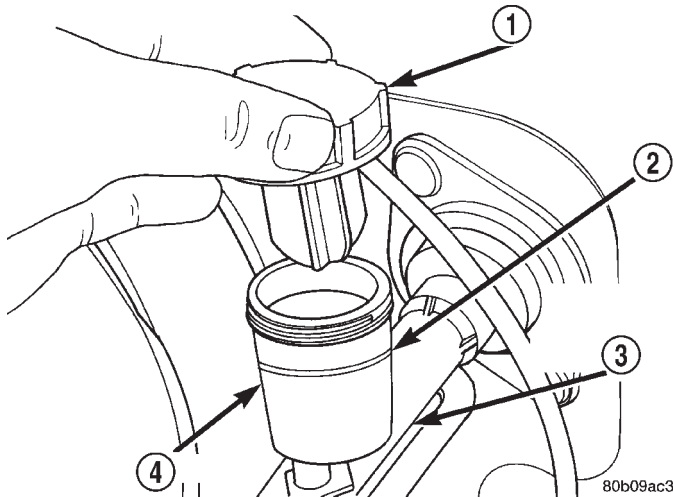

Fig. 7 Clutch Master Cylinder

- 1 - CAP
- 2 - FILL LINE
- 3 - CLUTCH MASTER CYLINDER
- 4 - RESERVOIR

OPERATION

The clutch linkage uses hydraulic pressure to operate the clutch. Depressing the clutch pedal develops fluid pressure in the clutch master cylinder. This pressure is transmitted to the slave cylinder through a connecting line. In turn, the slave cylinder operates the clutch release lever.

Slave cylinder force causes the release lever to move the release bearing into contact with the diaphragm spring. As additional force is applied, the bearing presses the diaphragm spring fingers inward on the fulcrums. This action moves the pressure plate rearward relieving clamp force on the disc.

DIAGNOSIS AND TESTING

SAFETY PRECAUTIONS

WARNING: EXERCISE CARE WHEN SERVICING CLUTCH COMPONENTS. FACTORY INSTALLED CLUTCH DISCS DO NOT CONTAIN ASBESTOS FIBERS. DUST AND DIRT ON CLUTCH PARTS MAY CONTAIN ASBESTOS FIBERS FROM AFTERMARKET

COMPONENTS. BREATHING EXCESSIVE CONCENTRATIONS OF THESE FIBERS CAN CAUSE SERIOUS BODILY HARM. WEAR A RESPIRATOR DURING SERVICE AND NEVER CLEAN CLUTCH COMPONENTS WITH COMPRESSED AIR OR WITH A DRY BRUSH. EITHER CLEAN THE COMPONENTS WITH A WATER DAMPENED RAGS OR USE A VACUUM CLEANER SPECIFICALLY DESIGNED FOR REMOVING ASBESTOS FIBERS AND DUST. DO NOT CREATE DUST BY SANDING A CLUTCH DISC. REPLACE THE DISC IF THE FRICTION MATERIAL IS DAMAGED OR CONTAMINATED. DISPOSE OF ALL DUST AND DIRT CONTAINING ASBESTOS FIBERS IN SEALED BAGS OR CONTAINERS. THIS WILL HELP MINIMIZE EXPOSURE TO YOURSELF AND TO OTHERS. FOLLOW ALL RECOMMENDED SAFETY PRACTICES PRESCRIBED BY THE OCCUPATIONAL SAFETY AND HEALTH ADMINISTRATION (OSHA) AND THE ENVIRONMENTAL SAFETY AGENCY (EPA), FOR THE HANDLING AND DISPOSAL OF PRODUCTS CONTAINING ASBESTOS.

INSTALLATION METHODS AND PARTS USAGE

Distortion of clutch components during installation and the use of non-standard components are common causes of clutch malfunction.

Improper clutch cover bolt tightening can distort the cover. The usual result is clutch grab, chatter and rapid wear. Tighten the cover bolts as described in Removal and Installation section.

An improperly seated flywheel and/or clutch housing are additional causes of clutch failure. Improper seating will produce misalignment and additional clutch problems.

The use of non-standard or low quality parts will also lead to problems and wear. Use recommended factory quality parts to avoid comebacks.

A cocked pilot bearing is another cause of clutch noise, drag, hard shifting, and rapid bearing wear. Always use an alignment tool to install a new bearing. This practice helps avoid cocking the bearing during installation.

CLUTCH DIAGNOSTIC INFORMATION

Unless the cause of a clutch problem is obvious, accurate problem diagnosis will usually require a road test to confirm a problem. Component inspection (Fig. 8) will then be required to determine the actual problem cause.

During a road test, drive the vehicle at normal speeds. Shift the transmission through all gear ranges and observe clutch action. If chatter, grab, slip, or improper release is experienced, remove and inspect the clutch components. However, if the problem is noise or hard shifting, further diagnosis may be needed as the transmission or another driveline component may be at fault. Careful observation during the test will help narrow the problem area.

DIAGNOSIS AND TESTING (Continued)

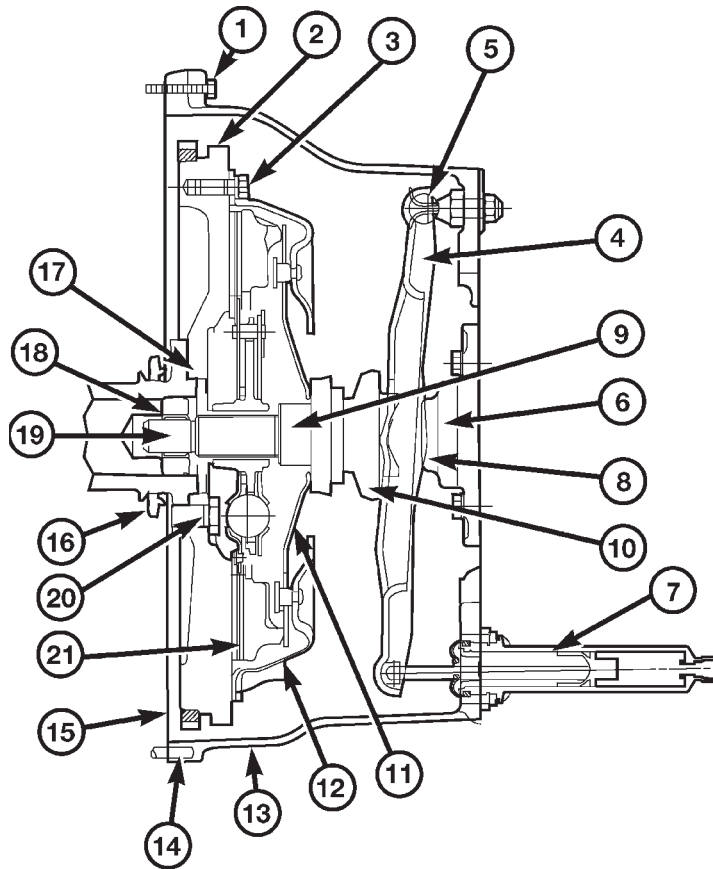

- 1 Check clutch housing bolts. Tighten if loose. Be sure housing is fully seated on engine block.
- 2 Check flywheel. Scuff sand face to remove glaze. Clean surface with wax and grease remover. Replace flywheel if severely scored, worn or cracked. Secure flywheel with new bolts (if removed). Do not reuse old bolts. Use Mopar Lock N'Seal on bolts.
- 3 Tighten clutch cover bolts 2-3 threads at a time, alternately and evenly (in a star pattern) to specified torque. Failure to do so could warp the cover.
- 4 Check release fork. Replace fork if bent or worn. Make sure pivot and bearing contact surfaces are lubricated.
- 5 Check release fork pivot (in housing). Be sure pivot is secure and ball end is lubricated.
- 6 Transmission input shaft bearing will cause noise, chatter, or improper release if damaged. Check condition before installing transmission.
- 7 Check slave cylinder. Replace it if leaking. Be sure cylinder is properly secured in housing and cylinder piston is seated in release fork.
- 8 Check input shaft seal if clutch cover and disc were oil covered. Replace seal if worn, or cut.
- 9 Inspect release bearing slide surface of trans. front bearing retainer. Surface should be smooth, free of nicks, scores. Replace retainer if necessary. Lubricate slide surface before installing release bearing.
- 10 Do not replace release bearing unless actually faulty. Replace bearing only if seized, noisy, or damaged.
- 11 Check clutch cover diaphragm spring and release fingers. Replace cover if spring or fingers are bent, warped, broken, cracked. Do not tamper with factory spring setting as clutch problems will result.
- 12 Check condition of clutch cover. Replace clutch cover if plate surface is deeply scored, warped, worn, or cracked. Be sure cover is correct size and properly aligned on disc and flywheel.
- 13 Inspect clutch housing. Be sure bolts are tight. Replace housing if damaged.
- 14 Verify that housing alignment dowels are in position before installing housing.
- 15 Clean engine block surface before installing clutch housing. Dirt, grime can produce misalignment.
- 16 Check rear main seal if clutch disc and cover were oil covered. Replace seal if necessary.
- 17 Check crankshaft flange (if flywheel is removed). Be sure flange is clean and flywheel bolt threads are in good condition.
- 18 Check pilot bearing. Replace bearing if damaged. Lube with Mopar high temp. bearing grease before installation.
- 19 Check transmission input shaft. Disc must slide freely on shaft splines. Lightly grease splines before installation. Replace shaft if splines or pilot bearing hub are damaged.
- 20 Check flywheel bolt torque. If bolts are loose, replace them. Use Mopar Lock N'Seal to secure new bolts.
- 21 Check clutch disc facing. Replace disc if facing is charred, scored, flaking off, or worn. Also check runout of new disc. Runout should not exceed 0.5 mm (0.02 in.).

Fig. 8 Clutch Components And Inspection

DIAGNOSIS AND TESTING (Continued)

CLUTCH CONTAMINATION

Fluid contamination is a frequent cause of clutch malfunctions. Oil, water, or clutch fluid on the clutch disc and pressure plate surfaces will cause chatter, slip and grab.

During inspection, note if any components are contaminated with oil, hydraulic fluid, or water/road splash.

Oil contamination indicates a leak at either the rear main seal or transmission input shaft. Oil leakage produces a residue of oil on the housing interior and on the clutch cover and flywheel. Heat buildup caused by slippage between the cover, disc and flywheel, can sometimes bake the oil residue onto the components. The glaze-like residue ranges in color from amber to black.

Road splash contamination means dirt/water is entering the clutch housing due to loose bolts, housing cracks, or through hydraulic line openings. Driving through deep water puddles can force water/road splash into the housing through such openings.

Clutch fluid leaks are usually from damaged slave cylinder push rod seals. This type of leak can only be confirmed by visual inspection.

IMPROPER CLUTCH RELEASE OR ENGAGEMENT

Clutch release or engagement problems are caused by wear, or damage to one or more clutch components. A visual inspection of the release components will usually reveal the problem part.

Release problems can result in hard shifting and noise. Items to look for are: leaks at the clutch cylinders and interconnecting line; loose slave cylinder bolts; worn/loose release fork and pivot stud; damaged release bearing; and a worn clutch disc, or pressure plate.

Normal condensation in vehicles that are stored or out of service for long periods of time can generate enough corrosion to make the disc stick to the flywheel, or pressure plate. If this condition is experienced, correction only requires that the disc be loosened manually through the inspection plate opening.

Engagement problems usually result in slip, chatter/shudder, and noisy operation. The primary causes are clutch disc contamination; clutch disc wear; misalignment, or distortion; flywheel damage; or a combination of the foregoing. A visual inspection is required to determine the part actually causing the problem.

CLUTCH MISALIGNMENT

Clutch components must be in proper alignment with the crankshaft and transmission input shaft. Misalignment caused by excessive runout or warpage

of any clutch component will cause grab, chatter and improper clutch release.

CLUTCH HOUSING MISALIGNMENT

Clutch housing alignment is important to proper clutch operation. The housing maintains alignment between the crankshaft and transmission input shaft. Misalignment can cause clutch noise, hard shifting, incomplete release and chatter. It can also result in premature wear of the pilot bearing, cover release fingers and clutch disc. In severe cases, misalignment can also cause premature wear of the transmission input shaft and front bearing.

Housing misalignment is generally caused by incorrect seating on the engine or transmission, loose housing bolts, missing alignment dowels, or housing damage. Infrequently, misalignment may also be caused by housing mounting surfaces that are not completely parallel. Misalignment can be corrected with shims.

CLUTCH FLYWHEEL RUNOUT

Check flywheel runout whenever misalignment is suspected. Flywheel runout should not exceed 0.08 mm (0.003 in.). Measure runout at the outer edge of the flywheel face with a dial indicator. Mount the indicator on a stud installed in place of one of the flywheel bolts.

Common causes of runout are:

- heat warpage
- improper machining
- incorrect bolt tightening
- improper seating on crankshaft flange shoulder
- foreign material on crankshaft flange

Flywheel machining is not recommended. The flywheel clutch surface is machined to a unique contour and machining will negate this feature. However, minor flywheel scoring can be cleaned up by hand with 180 grit emery, or with surface grinding equipment. Remove only enough material to reduce scoring (approximately 0.001 - 0.003 in.). Heavy stock removal is **not recommended**. Replace the flywheel if scoring is severe and deeper than 0.076 mm (0.003 in.). Excessive stock removal can result in flywheel cracking or warpage after installation; it can also weaken the flywheel and interfere with proper clutch release.

Clean the crankshaft flange before mounting the flywheel. Dirt and grease on the flange surface may cock the flywheel causing excessive runout. Use new bolts when remounting a flywheel and secure the bolts with Mopar® Lock And Seal. Tighten flywheel bolts to specified torque only. Overtightening can distort the flywheel hub causing runout.

DIAGNOSIS AND TESTING (Continued)

CLUTCH COVER AND DISC RUNOUT

Check the clutch disc before installation. Axial (face) runout of a **new** disc should not exceed 0.50 mm (0.020 in.). Measure runout about 6 mm (1/4 in.) from the outer edge of the disc facing. Obtain another disc if runout is excessive.

Check condition of the clutch before installation. A warped cover or diaphragm spring will cause grab and incomplete release or engagement. Be careful when handling the cover and disc. Impact can distort the cover, diaphragm spring, release fingers and the hub of the clutch disc.

Use an alignment tool when positioning the disc on the flywheel. The tool prevents accidental misalignment which could result in cover distortion and disc damage.

A frequent cause of clutch cover distortion (and consequent misalignment) is improper bolt tightening.

CLUTCH DIAGNOSIS CHARTS

The clutch inspection chart (Fig. 8) outlines items to be checked before and during clutch installation. Use the chart as a check list to help avoid overlooking potential problem sources during service operations.

The diagnosis charts describe common clutch problems, causes and correction. Fault conditions are listed at the top of each chart. Conditions, causes and corrective action are outlined in the indicated columns.

The charts are provided as a convenient reference when diagnosing faulty clutch operation.

DIAGNOSIS CHART

| CONDITION | POSSIBLE CAUSES | CORRECTION |
|--|--|--|
| Disc facing worn out | 1. Normal wear. 2. Driver frequently rides (slips) the clutch. Results in rapid overheating and wear. 3. Insufficient clutch cover diaphragm spring tension. | 1. Replace cover and disc. 2. Replace cover and disc. 3. Replace cover and disc. |
| Clutch disc facing contaminated with oil, grease, or clutch fluid. | 1. Leak at rear main engine seal or transmission input shaft seal. 2. Excessive amount of grease applied to the input shaft splines. 3. Road splash, water entering housing. 4. Slave cylinder leaking. | 1. Replace appropriate seal. 2. Remove grease and apply the correct amount of grease. 3. Replace clutch disc. Clean clutch cover and reuse if in good condition. 4. Replace hydraulic clutch linkage. |
| Clutch is running partially disengaged. | 1. Release bearing sticking or binding and does not return to the normal running position. | 1. Verify failure. Replace the release bearing and transmission front bearing retainer as necessary. |
| Flywheel below minimum thickness specification. | 1. Improper flywheel machining. Flywheel has excessive taper or excessive material removal. | 1. Replace flywheel. |
| Clutch disc, cover and/or diaphragm spring warped or distorted. | 1. Rough handling. Impact bent cover, spring, or disc. 2. Improper bolt tightening procedure. | 1. Replace disc or cover as necessary. 2. Tighten clutch cover using proper procedure. |

DIAGNOSIS AND TESTING (Continued)

| CONDITION | POSSIBLE CAUSES | CORRECTION |
|--|---|--|
| Facing on flywheel side of disc torn, gouged, or worn. | <ol style="list-style-type: none"> 1. Flywheel surface scored or nicked. 2. Clutch disc sticking or binding on transmission input shaft. | <ol style="list-style-type: none"> 2. Correct surface condition if possible. Replace flywheel and disc as necessary. 2. Inspect components and correct/replace as necessary. |
| Clutch disc facing burnt. Flywheel and cover pressure plate surfaces heavily glazed. | <ol style="list-style-type: none"> 1. Frequent operation under high loads or hard acceleration conditions. 2. Driver frequently rides (slips) clutch. Results in rapid wear and overheating of disc and cover. | <ol style="list-style-type: none"> 1. Correct condition of flywheel and pressure plate surface. Replace clutch cover and disc. Alert driver to problem cause. 2. Correct condition of flywheel and pressure plate surface. Replace clutch cover and disc. Alert driver to problem cause. |
| Clutch disc binds on input shaft splines. | <ol style="list-style-type: none"> 1. Clutch disc hub splines damaged during installation. 2. Input shaft splines rough, damaged, or corroded. | <ol style="list-style-type: none"> 1. Clean, smooth, and lubricate hub splines if possible. Replace disc if necessary. 2. Clean, smooth, and lubricate shaft splines if possible. Replace input shaft if necessary. |
| Clutch disc rusted to flywheel and/or pressure plate. | <ol style="list-style-type: none"> 1. Clutch not used for and extended period of time (e.g. long term vehicle storage). | <ol style="list-style-type: none"> 1. Sand rusted surfaces with 180 grit sanding paper. Replace clutch cover and flywheel if necessary. |
| Pilot bearing seized, loose, or rollers are worn. | <ol style="list-style-type: none"> 1. Bearing cocked during installation. 2. Bearing defective. 3. Bearing not lubricated. 4. Clutch misalignment. | <ol style="list-style-type: none"> 1. Install and lubricate a new bearing. 2. Install and lubricate a new bearing. 3. Install and lubricate a new bearing. 4. Inspect clutch and correct as necessary. Install and lubricate a new bearing. |
| Clutch will not disengage properly. | <ol style="list-style-type: none"> 1. Low clutch fluid level. 2. Clutch cover loose. 3. Clutch disc bent or distorted. 4. Clutch cover diaphragm spring bent or warped. 5. Clutch disc installed backwards. 6. Release fork bent or fork pivot loose or damaged. 7. Clutch master or slave cylinder failure. | <ol style="list-style-type: none"> 1. Replace hydraulic linkage assembly. 2. Follow proper bolt tightening procedure. 3. Replace clutch disc. 4. Replace clutch cover. 5. Remove and install clutch disc correctly. 6. Replace fork or pivot as necessary. 7. Replace hydraulic linkage assembly. |

DIAGNOSIS AND TESTING (Continued)

| CONDITION | POSSIBLE CAUSES | CORRECTION |
|--|---|--|
| Clutch pedal squeak. | 1. Pivot pin loose. 2. Master cylinder bushing not lubricated. 3. Pedal bushings worn out or cracked. | 1. Tighten pivot pin if possible. Replace clutch pedal if necessary. 2. Lubricate master cylinder bushing. 3. Replace and lubricate bushings. |
| Clutch master or slave cylinder plunger dragging and/or binding | 1. Master or slave cylinder components worn or corroded. | 1. Replace clutch hydraulic linkage assembly. |
| Release bearing is noisy. | 1. Release bearing defective or damaged. | 1. Replace release bearing. |
| Contact surface of release bearing damaged. | 1. Clutch cover incorrect or release fingers bent or distorted. 2. Release bearing defective or damaged. 3. Release bearing misaligned. | 1. Replace clutch cover and release bearing. 2. Replace the release bearing. 3. Check and correct runout of clutch components. Check front bearing sleeve for damage/alignment. Repair as necessary. |
| Partial engagement of clutch disc. One side of disc is worn and the other side is glazed and lightly worn. | 1. Clutch pressure plate position incorrect. 2. Clutch cover, spring, or release fingers bent or distorted. 3. Clutch disc damaged or distorted. 4. Clutch misalignment. | 1. Replace clutch disc and cover. 2. Replace clutch disc and cover. 2. Replace clutch disc. 4. Check alignment and runout of flywheel, disc, pressure plate, and/or clutch housing. Correct as necessary. |

SERVICE PROCEDURES

CLUTCH COMPONENT LUBRICATION

Proper clutch component lubrication is important to satisfactory operation. Using the correct lubricant and not over lubricating are equally important. Apply recommended lubricant sparingly to avoid disc and pressure plate contamination.

Clutch and transmission components requiring lubrication are:

- Pilot bearing.
- Release lever pivot ball stud.
- Release lever contact surfaces.
- Release bearing bore.
- Clutch disc hub splines.
- Clutch pedal pivot shaft bore.
- Clutch pedal bushings.
- Input shaft splines.

- Input shaft pilot hub.
- Transmission front bearing retainer slide surface.

NOTE: Never apply grease to any part of the clutch cover, or disc.

RECOMMENDED LUBRICANTS

Use Mopar® multi-purpose grease for the clutch pedal bushings and pivot shaft. Use Mopar® high temperature grease (or equivalent) for all other lubrication requirements. Apply recommended amounts and do not over lubricate.

CLUTCH LINKAGE FLUID

If inspection or diagnosis indicates additional fluid may be needed, use Mopar® brake fluid, or an equiv-

SERVICE PROCEDURES (Continued)

alent meeting standards SAE J1703 and DOT 3. Do not use any other type of fluid.

CLUTCH FLUID LEVEL

The clutch fluid reservoir, master cylinder, slave cylinder and fluid lines are pre-filled with fluid at the factory during assembly operations.

The hydraulic system should not require additional fluid under normal circumstances. In fact, **the reservoir fluid level will actually increase as normal clutch wear occurs. For this reason, it is important to avoid overfilling, or removing fluid from the reservoir.**

Clutch fluid level is checked at the master cylinder reservoir (Fig. 9). An indicator ring is provided on the outside rim of the reservoir.

Be sure to wipe the reservoir and cover clean before removing the cover. This will avoid having dirt or foreign material fall into the reservoir during a fluid level check.

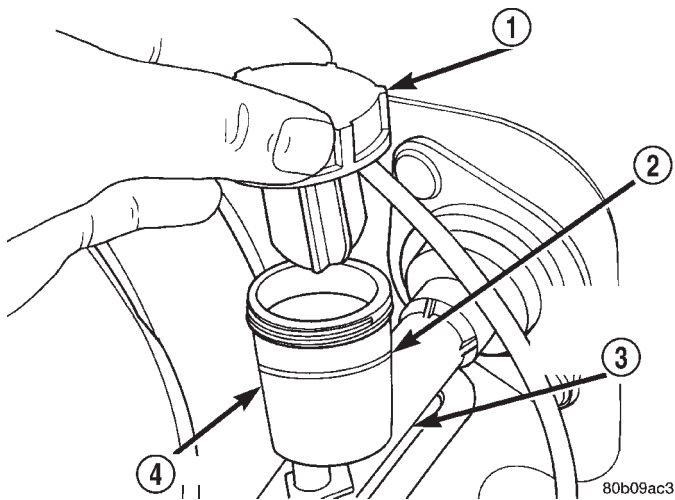

Fig. 9 Clutch Master Cylinder Reservoir And Cap

- 1 - CAP
- 2 - FILL LINE
- 3 - CLUTCH MASTER CYLINDER
- 4 - RESERVOIR

FLYWHEEL

Inspect the flywheel whenever the clutch disc, cover and housing are removed for service. Check condition of the flywheel face, hub, ring gear teeth, and flywheel bolts.

Minor scratches, burrs, or glazing on the flywheel face can be reduced with 180 grit emery cloth. However, the flywheel should be replaced if the disc contact surface is severely scored, heat checked, cracked, or obviously worn.

Flywheel machining is not recommended. The flywheel surface is manufactured with a unique contour that would be negated by machining. However,

cleanup of minor flywheel scoring can be performed by hand with 180 grit emery, or with surface grinding equipment. Replace the flywheel if scoring is deeper than 0.0762 mm (0.003 in.).

Heavy stock removal by grinding is **not recommended**. Excessive stock removal can result in flywheel cracking or warpage after installation. It can also weaken the flywheel and interfere with proper clutch release.

Check flywheel runout if misalignment is suspected. Runout should not exceed 0.08 mm (0.003 in.). Measure runout at the outer edge of the flywheel face with a dial indicator. Mount the dial indicator on a stud installed in place of one of the clutch housing attaching bolts.

Clean the crankshaft flange before mounting the flywheel. Dirt and grease on the flange surface may cock the flywheel causing excessive runout.

Check condition of the flywheel hub and attaching bolts. Replace the flywheel if the hub exhibits cracks in the area of the attaching bolt holes.

Install new attaching bolts whenever the flywheel is replaced and use Mopar® Lock N' Seal, or Loctite 242 on the replacement bolt threads.

Recommended flywheel bolt torques are:

- 142 N·m (105 ft. lbs.) for 6-cylinder flywheels
- 95 N·m (70 ft. lbs.) for 4-cylinder flywheels

Inspect the teeth on the starter ring gear. **If the teeth are worn or damaged, the flywheel should be replaced as an assembly. This is the recommended and preferred method of repair.**

In cases where a new flywheel is not readily available, a replacement ring gear can be installed. However, the following precautions must be observed to avoid damaging the flywheel and replacement gear.

(1) Mark position of the old gear for alignment reference on the flywheel. Use a scribe for this purpose.

(2) Wear protective goggles or approved safety glasses. Also wear heat resistant gloves when handling a heated ring gear.

(3) Remove the old gear by cutting most of the way through it (at one point) with an abrasive cut-off wheel. Then complete removal with a cold chisel or punch.

(4) The ring gear is a shrink fit on the flywheel. This means the gear must be expanded by heating in order to install it. **The method of heating and expanding the gear is extremely important.** Every surface of the gear must be heated at the same time to produce uniform expansion. An oven or similar enclosed heating device must be used. Temperature required for uniform expansion is approximately 375° F.

SERVICE PROCEDURES (Continued)

CAUTION: Do not use an oxy/acetylene torch to remove the old gear, or to heat and expand a new gear. The high temperature of the torch flame can cause localized heating that will damage the flywheel. In addition, using the torch to heat a replacement gear will cause uneven heating and expansion. The torch flame can also anneal the gear teeth resulting in rapid wear and damage after installation.

(5) The heated gear must be installed evenly to avoid misalignment or distortion. A shop press and suitable press plates should be used to install the gear if at all possible.

(6) Be sure to wear eye and hand protection. Heat resistant gloves and safety goggles are needed for personal safety. Also use metal tongs, vise grips, or similar tools to position the gear as necessary for installation.

(7) Allow the flywheel and ring gear to cool down before installation. Set the assembly on a workbench and let it cool in normal shop air.

CAUTION: Do not use water, or compressed air to cool the flywheel. The rapid cooling produced by water or compressed air can distort, or crack the gear and flywheel.

REMOVAL AND INSTALLATION

CLUTCH COVER AND DISC

REMOVAL

(1) Remove transmission. Refer to procedures in Group 21.

(2) If original clutch cover will be reinstalled, mark position of cover on flywheel for assembly reference. Use paint or a scribe for this purpose.

(3) If clutch cover is to be replaced, cover bolts can be removed in any sequence. However, if original cover will be reinstalled, loosen cover bolts evenly and in rotation to relieve spring tension equally. This is necessary to avoid warping cover.

(4) Remove cover bolts and remove cover and disc (Fig. 10).

INSTALLATION

(1) Lightly scuff sand flywheel face with 180 grit emery cloth. Then clean surface with a wax and grease remover.

(2) Lubricate pilot bearing with Mopar high temperature bearing grease.

(3) Check runout and free operation of new clutch disc as follows:

(a) Slide disc onto transmission input shaft splines. Disc should slide freely on splines.

(b) Leave disc on shaft and check face runout with dial indicator. Check runout at disc hub and about 6 mm (1/4 in.) from outer edge of facing.

(c) Face runout should not exceed 0.5 mm (0.020 in.). Obtain another clutch disc if runout exceeds this limit.

(4) Position clutch disc on flywheel. Be sure side of disc marked flywheel side is positioned against flywheel (Fig. 10). If disc is not marked, be sure flat side of disc hub is toward flywheel.

(5) Inspect condition of pressure plate surface of clutch cover (Fig. 10). Replace cover if this surface is worn, heat checked, cracked, or scored.

(6) Insert clutch alignment tool in clutch disc (Fig. 11).

(7) Insert alignment tool in pilot bearing and position disc on flywheel. Be sure disc hub is positioned correctly. Side of hub marked Flywheel Side should face flywheel (Fig. 10). If disc is not marked, place flat side of disc against flywheel.

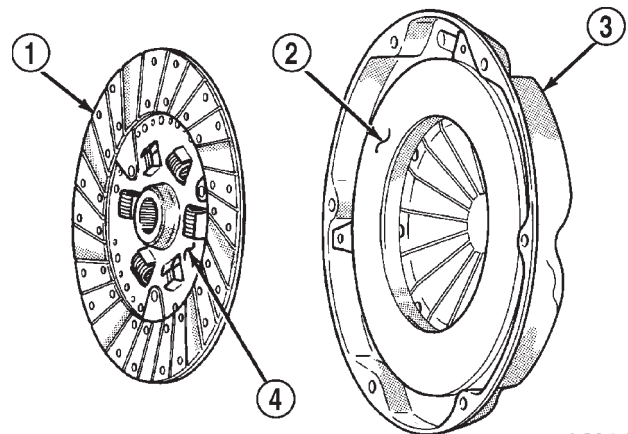

Fig. 10 Clutch Disc And Pressure Plate Inspection

- 1 - DISC
- 2 - INSPECT THIS SURFACE
- 3 - CLUTCH COVER
- 4 - "FLYWHEEL SIDE" STAMPED ON THIS SURFACE

(8) Position clutch cover over disc and on flywheel (Fig. 11).

(9) Install clutch cover bolts finger tight.

(10) Tighten cover bolts evenly and in rotation a few threads at a time. **Cover bolts must be tightened evenly and to specified torque to avoid distorting cover. Tightening torques are 31 N·m (23 ft. lbs.) on 2.5L engines and 50N·m (37ft. lbs.) on 4.0 L engines.**

(a) Start all 6 bolts by hand.

(b) Tighten 3 pilot hole bolts 3/4s of the way (any sequence).

REMOVAL AND INSTALLATION (Continued)

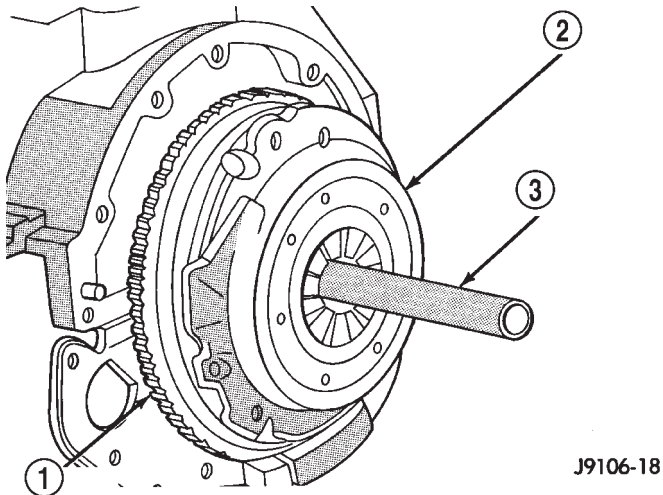

J9106-18

Fig. 11 Typical Method Of Aligning Clutch Disc

- 1 - FLYWHEEL
2 - CLUTCH COVER AND DISC
3 - CLUTCH DISC ALIGNMENT TOOL

(c) Starting 180 degrees from the last pilot bolt, tighten 3 large hole bolts 3/4s of the way (any sequence).

(d) Tighten 3 pilot hole bolts all the way (any sequence).

(e) Starting 180 degrees from last pilot bolt, tighten 3 large bolts all the way (any sequence).

(11) Apply light coat of Mopar® high temperature bearing grease to clutch disc hub and splines of transmission input shaft. **Do not over lubricate shaft splines. This will result in grease contamination of disc.**

(12) Install transmission.

RELEASE BEARING**REMOVAL**

- (1) Remove transmission.
- (2) Disconnect release bearing from release lever and remove bearing (Fig. 12).
- (3) Inspect bearing slide surface of transmission front bearing retainer. Replace retainer if slide surface is scored, worn, or cracked.
- (4) Inspect release fork and fork pivot. Be sure pivot is secure and in good condition. Be sure fork is not distorted or worn. Replace release fork retainer spring if bent or damaged.

INSTALLATION

- (1) Lubricate crankshaft pilot bearing with Mopar® high temperature bearing grease. Apply grease to end of long shank, small diameter flat blade screwdriver. Then insert tool through clutch disc hub to reach bearing.

(2) Lubricate input shaft splines, bearing retainer slide surface, fork pivot and release fork pivot surface with Mopar® high temperature grease.

(3) Install new release bearing. Be sure bearing is properly secured to release fork.

(4) Install transmission.

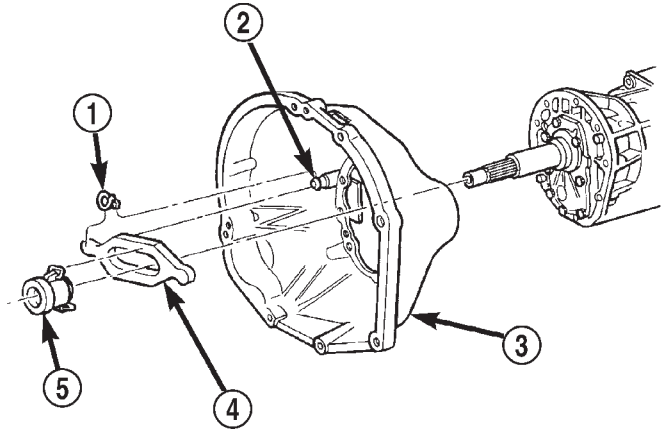

80a5570d

Fig. 12 Release Bearing Attachment

- 1 - RETURN SPRING
2 - PIVOT BALL STUD
3 - CLUTCH HOUSING
4 - RELEASE FORK
5 - RELEASE BEARING

PILOT BEARING**REMOVAL**

- (1) Remove transmission. Refer to Group 21, Transmission and Transfer Case, for proper procedures.
- (2) Remove clutch cover and disc.
- (3) Use a suitable blind hole puller to remove pilot bearing.

INSTALLATION

- (1) Clean bearing bore with solvent and wipe dry with shop towel.
- (2) Lubricate new pilot bearing with Mopar® high temperature grease.
- (3) Position and start new bearing in bearing bore by hand. Note that pilot bearing has seal at one end. Install bearing so seal is facing outward toward transmission.
- (4) Seat pilot bearing with clutch alignment tool (Fig. 13). Keep bearing straight during installation. Do not allow bearing to become cocked. Tap bearing into place until flush with edge of bearing bore. Do not recess bearing.
- (5) Install transmission. Refer to Group 21, Transmission and Transfer Case, for proper procedures.

REMOVAL AND INSTALLATION (Continued)

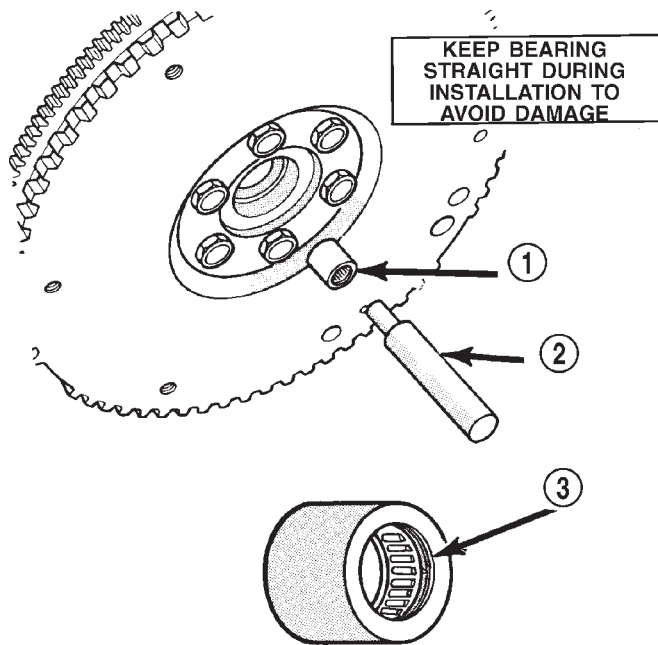

J9206-8

Fig. 13 Typical Method Of Installing Pilot Bearing

- 1 - PILOT BEARING
- 2 - ALIGNMENT TOOL
- 3 - BEARING SEAL MUST FACE TRANSMISSION

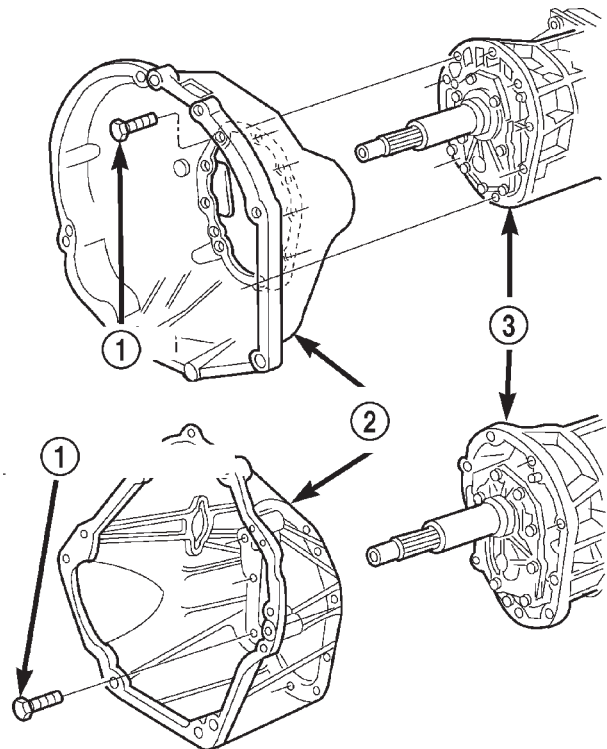

80be4510

Fig. 14 Clutch Housing Attachment

- 1 - HOUSING-TO-TRANSMISSION BOLTS (46 N·m/34 ft. lbs.)
- 2 - CLUTCH HOUSING
- 3 - TRANSMISSION

CLUTCH HOUSING

The clutch housing is removable and can be replaced when the transmission is out of the vehicle.

The bolts attaching the housing to the transmission case are located inside the housing (Fig. 14). Recommended tightening torque for the clutch housing-to-transmission bolts is 46 N·m (34 ft. lbs.).

NOTE: Be sure the transmission and housing mating surfaces are clean before installing an original, or replacement clutch housing. Dirt/foreign material trapped between the housing and transmission will cause misalignment. If misalignment is severe enough, the result will be clutch drag, incomplete release and hard shifting.

CLUTCH HYDRAULIC LINKAGE

The clutch master cylinder, slave cylinder and connecting line are serviced as an assembly only. The linkage components cannot be overhauled or serviced separately. The cylinders and connecting line are sealed units. Also note that removal/installation procedures for right and left hand drive models are basically the same. Only master cylinder location is different.

REMOVAL

- (1) Raise vehicle.
- (2) Remove fasteners attaching slave cylinder to clutch housing.
- (3) Remove slave cylinder from clutch housing (Fig. 15).
- (4) Disengage clutch fluid line from body clips, if applicable.
- (5) Lower vehicle.
- (6) Verify that cap on clutch master cylinder reservoir is tight. This is necessary to avoid spilling fluid during removal.
- (7) Remove clutch master cylinder attaching nuts (Fig. 16) or (Fig. 17).
- (8) Disengage captured bushing on clutch master cylinder actuator from pivot pin on pedal arm (Fig. 18).
- (9) Slide actuator off pivot pin.
- (10) Disconnect clutch interlock safety switch wires.
- (11) Remove clutch hydraulic linkage through engine compartment.

REMOVAL AND INSTALLATION (Continued)

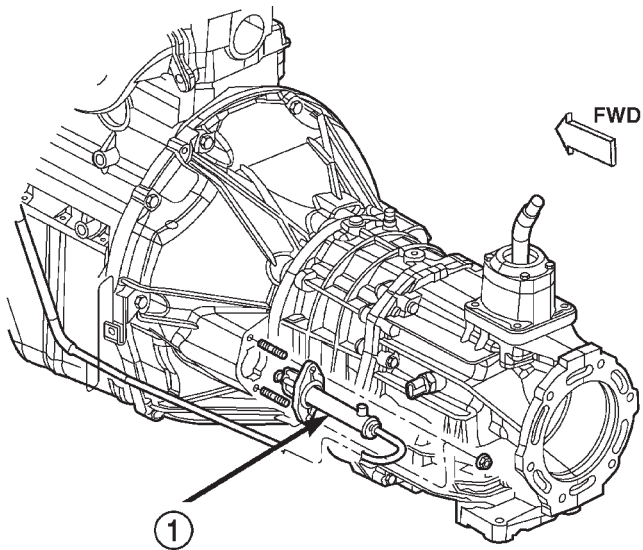

80be45f3

Fig. 15 Slave Cylinder

1 - CLUTCH SLAVE CYLINDER

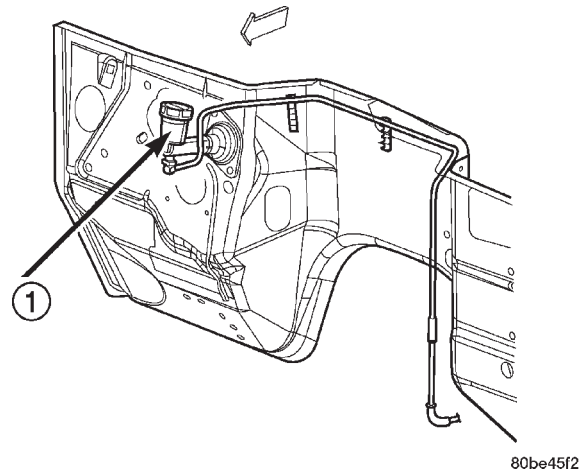

80be45f2

Fig. 17 Right Hand Drive Clutch Master Cylinder

1 - CLUTCH MASTER CYLINDER

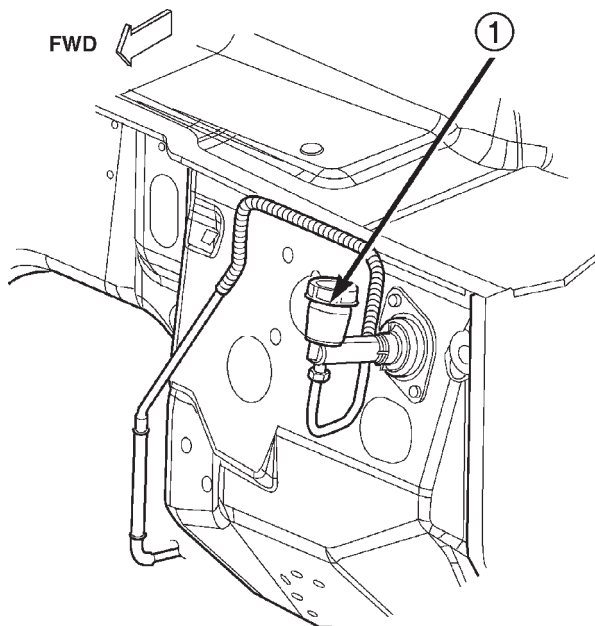

80be45f1

Fig. 16 Left Hand Drive Clutch Master Cylinder

1 - CLUTCH MASTER CYLINDER

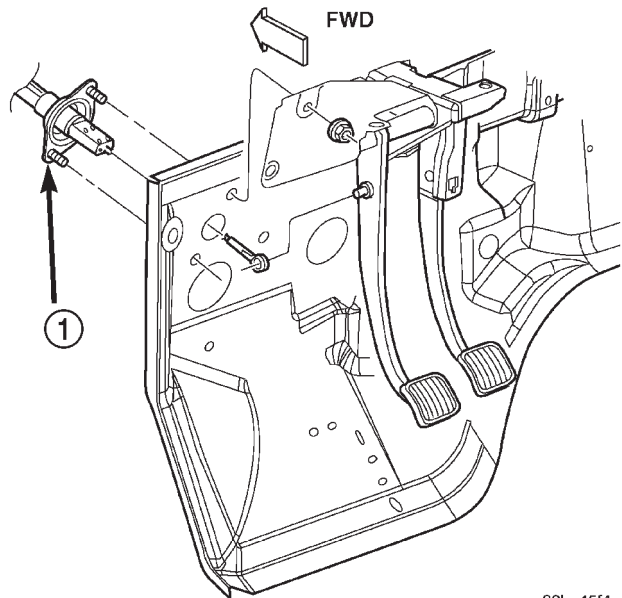

80be45f4

Fig. 18 Clutch Pedal Attachment

1 - CLUTCH MASTER CYLINDER

INSTALLATION

(1) Be sure reservoir cover on clutch master cylinder is tight to avoid spills.

(2) Position clutch linkage components in vehicle. Work connecting line and slave cylinder downward past engine and adjacent to clutch housing (Fig. 16) or (Fig. 17).

(3) Position clutch master cylinder on dash panel (Fig. 16) or (Fig. 17).

(4) Attach clutch master cylinder actuator to pivot pin on clutch pedal (Fig. 18).

(5) Install and tighten clutch master cylinder attaching nuts to 38 N·m (28 ft. lbs.) torque.

(6) Raise vehicle.

(7) Insert slave cylinder push rod through clutch housing opening and into release lever. Be sure cap on end of rod is securely engaged in lever. Check this before installing cylinder attaching nuts.

(8) Install and tighten slave cylinder attaching nuts to 23 N·m (17 ft. lbs.) torque.

REMOVAL AND INSTALLATION (Continued)

- (9) Secure clutch fluid line in body and transmission clips.
- (10) Lower vehicle.
- (11) Connect clutch interlock safety switch wires.

SPECIFICATIONS

TORQUE

| DESCRIPTION | TORQUE |
|---------------------------------------|-----------------------|
| Bolts, clutch cover 2.5 L | 31 N·m (23 ft. lbs) |
| Bolts, clutch cover 4.0 L | 50 N·m (37 ft. lbs) |
| Bolt/Nut, clutch cyl. mount | 23 N·m (200 in. lbs) |
| Bolt, clutch housing M12 | 75 N·m (55 ft. lbs) |
| Bolt, clutch housing 3/8 | 37 N·m (27 ft. lbs) |
| Bolt, clutch housing 7/16 | 58 N·m (43 ft. lbs) |
| Bolt, clutch housing/trans. | 46 N·m (34 ft. lbs) |
| Bolt, dust shield M8 | 8 N·m (72 in. lbs) |
| Bolt, dust shield lower | 50 N·m (37 ft. lbs) |
| Bolt, X-member/frame | 41 N·m (30 ft. lbs) |
| Bolt, X-member/rear support | 45 N·m (33 ft. lbs.) |
| Bolts, flywheel 4.0 L | 142 N·m (105 ft. lbs) |
| Bolts, flywheel 2.5 L | 95 N·m (70 ft. lbs) |
| Bolt, starter motor | 45 N·m (33 ft. lbs) |
| Bolts, U-joints | 19 N·m (170 in. lbs.) |

