

# COOLING SYSTEM

## TABLE OF CONTENTS

	page	page
<b>DESCRIPTION AND OPERATION</b>		
COOLING SYSTEM . . . . .	1	
AUTOMATIC TRANSMISSION OIL COOLER . . . . .	2	
COOLANT RESERVE/OVERFLOW SYSTEM . . . . .	2	
COOLING SYSTEM FANS . . . . .	3	
BLOCK HEATER . . . . .	4	
THERMOSTAT . . . . .	4	
RADIATOR . . . . .	5	
RADIATOR PRESSURE CAP . . . . .	5	
WATER PUMP . . . . .	6	
HOSE CLAMPS . . . . .	6	
VISCOUS FAN DRIVE . . . . .	7	
ELECTRIC COOLING FAN . . . . .	8	
<b>DIAGNOSIS AND TESTING</b>		
ON-BOARD DIAGNOSTICS (OBD) . . . . .	9	
DRB SCAN TOOL . . . . .	9	
ACCESSORY DRIVE BELT DIAGNOSIS . . . . .	9	
PRELIMINARY CHECKS . . . . .	11	
RADIATOR COOLANT FLOW CHECK . . . . .	17	
COOLING SYSTEM—TESTING FOR LEAKS . . . . .	17	
VISCOUS FAN DRIVE . . . . .	19	
ELECTRIC COOLING FAN . . . . .	19	
RADIATOR CAP-TO-FILLER NECK SEAL—PRESSURE RELIEF CHECK . . . . .	20	
RADIATOR CAP—PRESSURE TESTING . . . . .	20	
COOLANT—LOW LEVEL AERATION . . . . .	21	
DEAERATION . . . . .	21	
<b>SERVICE PROCEDURES</b>		
COOLANT—ROUTINE LEVEL CHECK . . . . .	21	
COOLANT—ADDING ADDITIONAL . . . . .	21	
		21
		21
		22
<b>REMOVAL AND INSTALLATION</b>		
TRANSMISSION OIL COOLERS . . . . .	23	
COOLANT RESERVE TANK . . . . .	23	
WATER PUMP . . . . .	24	
THERMOSTAT . . . . .	28	
RADIATOR—2.5L . . . . .	29	
RADIATOR—4.0L . . . . .	31	
ELECTRIC COOLING FAN—2.5L . . . . .	33	
ELECTRIC COOLING FAN—4.0L . . . . .	34	
BLOCK HEATER . . . . .	35	
ENGINE ACCESSORY DRIVE BELTS . . . . .	35	
COOLING SYSTEM FANS . . . . .	38	
VISCOUS FAN DRIVE REMOVAL/ INSTALLATION . . . . .	39	
<b>CLEANING AND INSPECTION</b>		
RADIATOR PRESSURE CAP . . . . .	39	
RADIATOR . . . . .	39	
WATER PUMP . . . . .	39	
FAN BLADE . . . . .	39	
COOLING SYSTEM HOSES . . . . .	40	
<b>SPECIFICATIONS</b>		
BELT TENSION . . . . .	40	
TORQUE SPECIFICATIONS . . . . .	40	
<b>SPECIAL TOOLS</b>		
COOLING . . . . .	40	

## DESCRIPTION AND OPERATION

### COOLING SYSTEM

#### DESCRIPTION

The cooling system regulates engine operating temperature. It allows the engine to reach normal operating temperature as quickly as possible, maintains normal operating temperature and prevents overheating.

The cooling system also provides a means of heating the passenger compartment and cooling the auto-

matic transmission fluid (if equipped). The cooling system is pressurized and uses a centrifugal water pump to circulate coolant throughout the system.

An optional factory installed heavy duty cooling package is available on most models. The package consists of a radiator that has an increased number of cooling fins. Vehicles equipped with a 2.5L/4.0L engine and heavy duty cooling and/or air conditioning also have an auxiliary electric cooling fan.

The cooling system consists of:

- A radiator
- Cooling fan (mechanical and/or electrical)
- Thermal viscous fan drive

## DESCRIPTION AND OPERATION (Continued)

- Fan shroud
- Radiator pressure cap
- Thermostat
- Coolant reserve/overflow system
- Transmission oil cooler (if equipped with an automatic transmission)
  - Coolant
  - Water pump
  - Hoses and hose clamps

Cooling system circulation for 2.5L/4.0L models is shown in (Fig. 1).

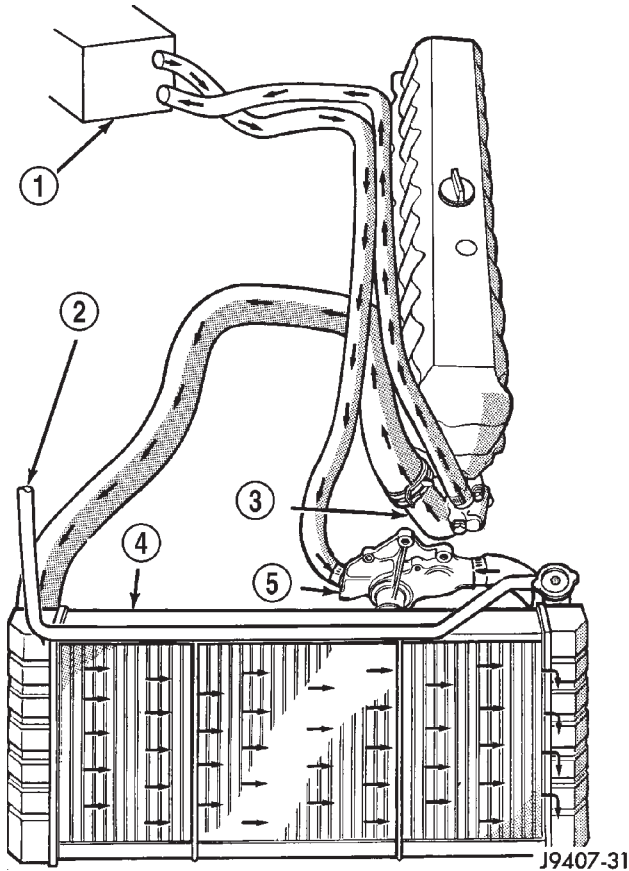

**Fig. 1 Coolant Circulation—2.5L/4.0L Engines**

- 1 - HEATER CORE
- 2 - TO COOLANT RESERVE/OVERFLOW TANK
- 3 - THERMOSTAT HOUSING
- 4 - RADIATOR
- 5 - WATER PUMP

## AUTOMATIC TRANSMISSION OIL COOLER

### DESCRIPTION

All models equipped with an automatic transmission are equipped with a transmission oil cooler mounted internally within the radiator tank. This internal cooler is supplied as standard equipment on all models equipped with an automatic transmission.

Transmission oil is cooled when it passes through this separate cooler. In case of a leak in the internal radiator mounted transmission oil cooler, engine coolant may become mixed with transmission fluid or transmission fluid may enter engine cooling system. Both cooling system and transmission should be drained and inspected if the internal radiator mounted transmission cooler is leaking.

An auxiliary air-to-oil transmission oil cooler is available with most engine packages.

The auxiliary air-to-oil transmission oil cooler is located in front of the radiator or A/C condenser (if equipped) and behind the grill. It is mounted to the front frame crossmember.

The auxiliary oil coolers on all models operate in conjunction with the internal radiator mounted main oil cooler. The transmission oil is routed through the main cooler first, then the auxiliary cooler, before returning to the transmission.

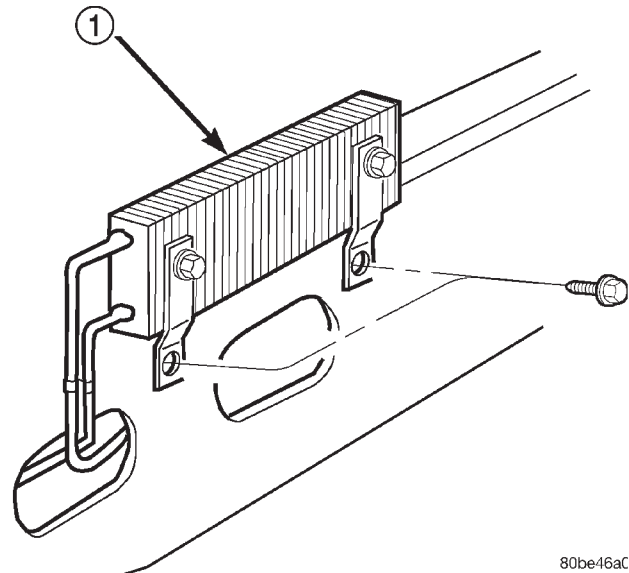

**Fig. 2 Auxiliary Transmission Oil Cooler**

- 1 - AUXILIARY TRANSMISSION OIL COOLER

## COOLANT RESERVE/OVERFLOW SYSTEM

### DESCRIPTION

The system works along with the radiator pressure cap. This is done by using thermal expansion and contraction of the coolant to keep the coolant free of trapped air. It provides:

- A volume for coolant expansion and contraction.
- A convenient and safe method for checking/adjusting coolant level at atmospheric pressure. This is done without removing the radiator pressure cap.
- Some reserve coolant to the radiator to cover minor leaks and evaporation or boiling losses.

DESCRIPTION AND OPERATION (Continued)

The coolant reserve/overflow system consists of a radiator mounted pressurized cap, a plastic reserve/overflow tank (Fig. 3) (Fig. 4), a tube (hose) connecting the radiator and tank, and an overflow tube on the side of the tank.

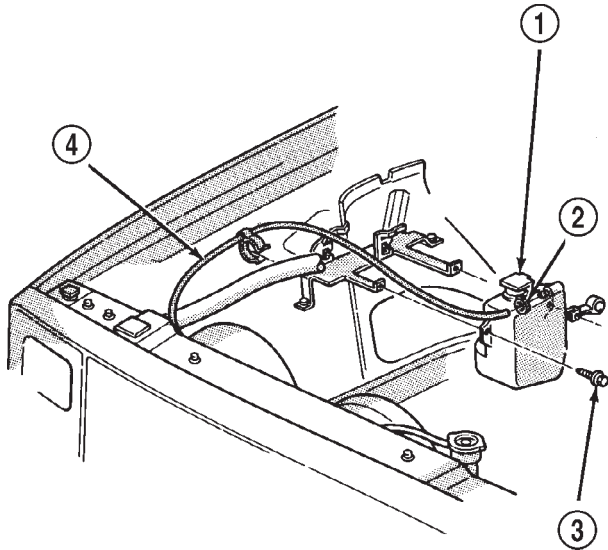

J9407-26

**Fig. 3 Reserve/Overflow Tank—Except Right Hand Drive**

- 1 - COOLANT RESERVE/OVERFLOW TANK
- 2 - CLAMP
- 3 - MOUNTING BOLTS
- 4 - TUBE TO RADIATOR

**OPERATION**

As the engine cools, a vacuum is formed in the cooling system of both the radiator and engine. Coolant will then be drawn from the coolant tank and returned to a proper level in the radiator.

**COOLING SYSTEM FANS**

**DESCRIPTION**

All models are equipped with a viscous fan. This thermal viscous fan drive is a torque-and-temperature-sensitive clutch unit. It automatically increases or decreases fan speed to provide proper engine cooling. Vehicles with a 2.5L/4.0L engine with air conditioning, or 4.0L with "max" cooling also have an auxiliary electrical cooling fan.

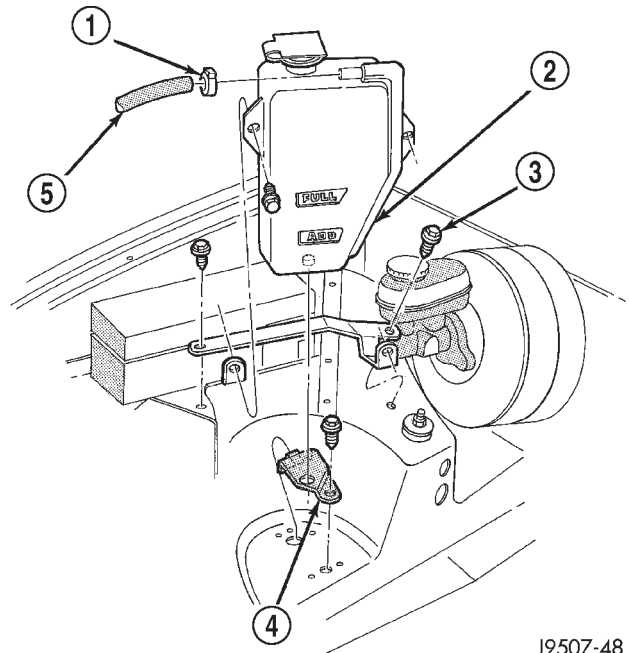

J9507-48

**Fig. 4 Reserve/Overflow Tank—With Right Hand Drive**

- 1 - CLAMP
- 2 - COOLANT RESERVE/OVERFLOW TANK
- 3 - MOUNTING BOLTS
- 4 - LOWER BRACKET
- 5 - TUBE TO RADIATOR

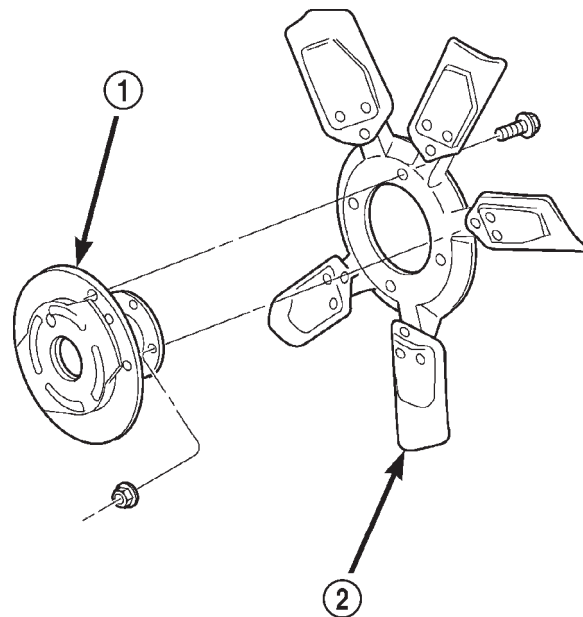

80be46a2

**Fig. 5 Viscous Fan Drive and Fan Blade Assembly**

- 1 - VISCIOUS FAN DRIVE
- 2 - FAN BLADE ASSEMBLY

## DESCRIPTION AND OPERATION (Continued)

## BLOCK HEATER

## DESCRIPTION

**WARNING: DO NOT OPERATE ENGINE UNLESS BLOCK HEATER CORD HAS BEEN DISCONNECTED FROM POWER SOURCE AND SECURED IN PLACE.**

An optional engine block heater is available for all models. The heater is equipped with a power cord. The cord is attached to an engine compartment component with tie-straps. The heater warms the engine providing easier engine starting and faster warm-up in low temperatures. The heater is mounted in a core hole of the engine cylinder block (in place of a freeze plug) with the heating element immersed in engine coolant.

**BLOCK HEATER SPECIFICATIONS**

- 2.5L 4-Cylinder Engine: 115 Volts 400 Watts
- 4.0L 6-Cylinder Engine: 120 Volts 600 Watts

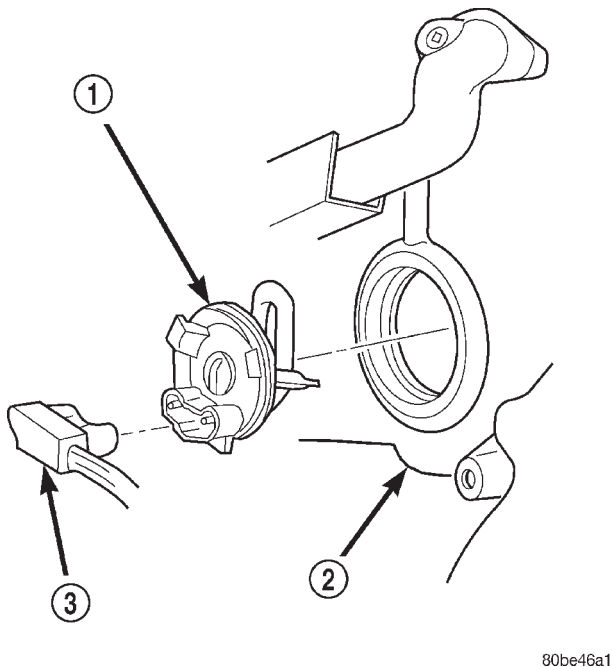

80be46a1

**Fig. 6 Engine Block Heater**

- 1 - BLOCK HEATER
- 2 - CYLINDER BLOCK
- 3 - BLOCK HEATER POWER CORD

## OPERATION

Connecting the power cord to a grounded 110-120 volt AC electrical outlet with a grounded, three-wire extension cord activates the block heater.

## THERMOSTAT

## DESCRIPTION

**CAUTION: Do not operate an engine without a thermostat, except for servicing or testing.**

A pellet-type thermostat controls the operating temperature of the engine by controlling the amount of coolant flow to the radiator. On all engines the thermostat is closed below 195°F (90°C). Above this temperature, coolant is allowed to flow to the radiator. This provides quick engine warm-up and overall temperature control.

An arrow plus the word **UP** is stamped on the front flange next to the air bleed. The words **TO RAD** are stamped on one arm of the thermostat. They indicate the proper installed position.

The same thermostat is used for winter and summer seasons. An engine should not be operated without a thermostat, except for servicing or testing. Operating without a thermostat causes other problems. These are: A 'check engine' light and a DTC will eventually be set, longer engine warm-up time, unreliable warm-up performance, increased exhaust emissions and crankcase condensation. This condensation can result in sludge formation.

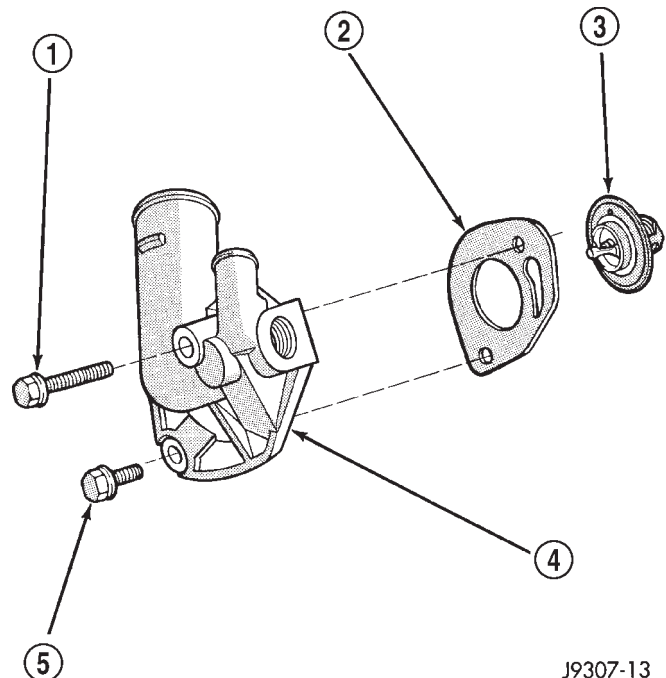

J9307-13

**Fig. 7 Thermostat and Housing**

- 1 - LONG BOLT
- 2 - GASKET
- 3 - THERMOSTAT
- 4 - THERMOSTAT HOUSING
- 5 - SHORT BOLT

DESCRIPTION AND OPERATION (Continued)

**RADIATOR**

**DESCRIPTION**

**CAUTION:** Plastic tanks, while stronger than brass, are subject to damage by impact, such as wrenches.

Radiators for both engines are the cross flow type. Plastic tanks are used on all radiators.

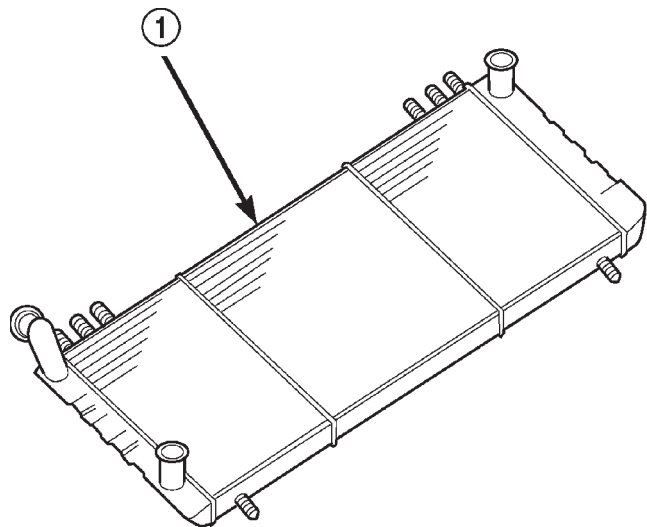

80be469f

**Fig. 8 Cross Flow Radiator**

1 - RADIATOR

A rubber gasket seals radiator filler neck. This is done to maintain vacuum during coolant cool-down and to prevent leakage when system is under pressure.

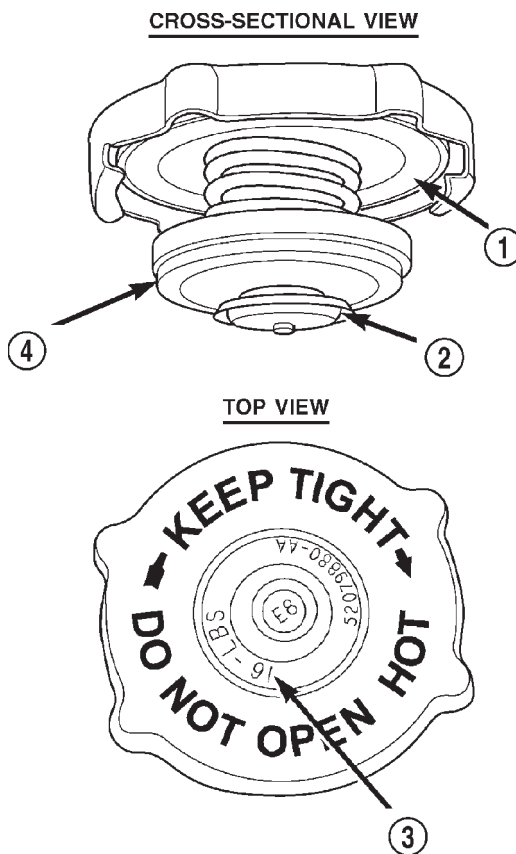

80bfe12f

**Fig. 9 Radiator Pressure Cap and Filler Neck—Typical**

- 1 - FILLER NECK SEAL
- 2 - VACUUM VENT VALVE
- 3 - PRESSURE RATING
- 4 - PRESSURE VALVE

**RADIATOR PRESSURE CAP**

**DESCRIPTION**

All radiators are equipped with a pressure cap. This cap releases pressure at some point within a range of 83-110 kPa (12-16 psi). The pressure relief point (in pounds) is engraved on top of the cap (Fig. 9).

The cooling system will operate at pressures slightly above atmospheric pressure. This results in a higher coolant boiling point allowing increased radiator cooling capacity. The cap contains a spring-loaded pressure relief valve that opens when system pressure reaches release range of 83-110 kPa (12-16 psi).

**OPERATION**

A vent valve in the center of cap allows a small coolant flow through cap when coolant is below boiling temperature. The valve is completely closed when boiling point is reached. As the coolant cools, it contracts and creates a vacuum in the cooling system. This causes the vacuum valve to open and coolant in the reserve/overflow tank to be drawn through its connecting hose into radiator. If the vacuum valve is stuck shut, the radiator hoses will collapse on cool-down.



## DESCRIPTION AND OPERATION (Continued)

## WATER PUMP

## DESCRIPTION

**CAUTION:** All engines are equipped with a reverse (counter-clockwise) rotating water pump and viscous fan drive assembly. REVERSE is stamped or imprinted on the cover of the viscous fan drive and inner side of the fan. The letter R is stamped into the back of the water pump impeller (Fig. 10).

A centrifugal water pump circulates coolant through the water jackets, passages, intake manifold, radiator core, cooling system hoses and heater core. The pump is driven from the engine crankshaft by a drive belt on all engines.

The water pump impeller is pressed onto the rear of a shaft that rotates in bearings pressed into the housing. The housing has a small hole to allow seepage to escape. The water pump seals are lubricated by the antifreeze in the coolant mixture. No additional lubrication is necessary.

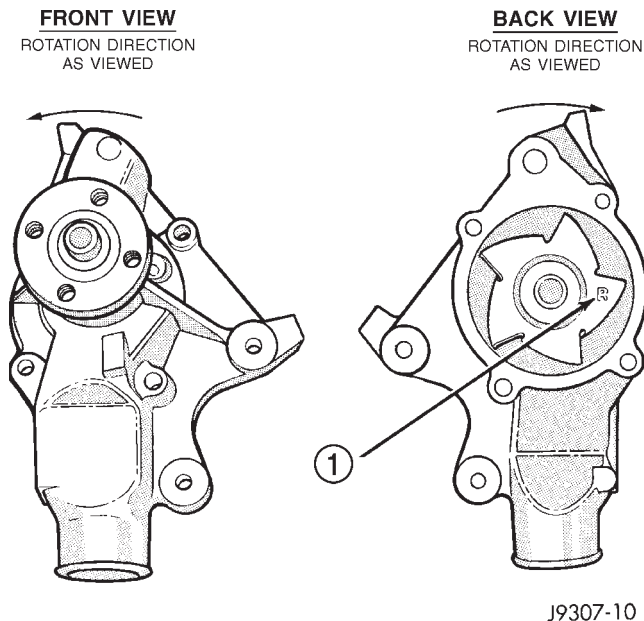

J9307-10

**Fig. 10 Reverse Rotating Water Pump—Typical**

1 - R STAMPED INTO IMPELLER

## HOSE CLAMPS

## DESCRIPTION

The cooling system utilizes both worm drive and spring type hose clamps. If a spring type clamp replacement is necessary, replace with the original Mopar® equipment spring type clamp.

**CAUTION:** A number or letter is stamped into the tongue of constant tension clamps. If replacement is necessary, use only a original equipment clamp with matching number or letter (Fig. 11).

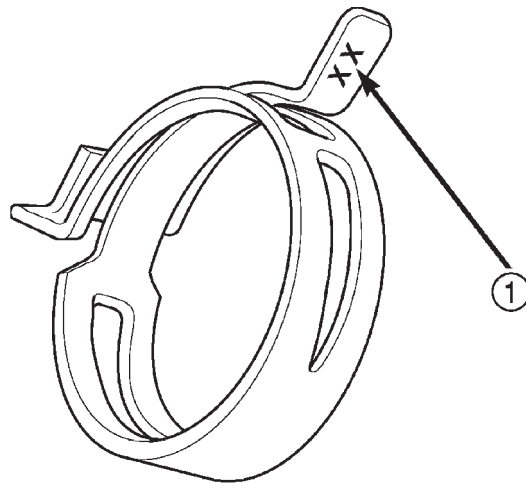

80b76ee

**Fig. 11 Spring Clamp Size Location**

1 - SPRING CLAMP SIZE LOCATION

## OPERATION

The worm type hose clamp uses a specified torque value to maintain proper tension on a hose connection.

The spring type hose clamp applies constant tension on a hose connection. To remove a spring type hose clamp, use Special Tool 6094 or equivalent, constant tension clamp pliers (Fig. 12) to compress the hose clamp.

DESCRIPTION AND OPERATION (Continued)

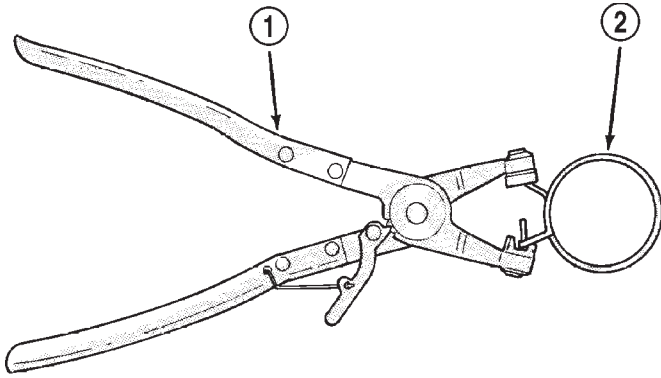

J9207-36

**Fig. 12 Hose Clamp Tool**

- 1 - HOSE CLAMP TOOL 6094
- 2 - HOSE CLAMP

VISCOUS FAN DRIVE

DESCRIPTION

**CAUTION:** Engines equipped with poly-V drive belts have reverse rotating fans and viscous fan drives. They are marked with the word REVERSE to designate their usage. Installation of the wrong fan or viscous fan drive can result in engine overheating.

The thermal viscous fan drive is a silicone-fluid-filled coupling used to connect the fan blades to either the engine or the water pump shaft. The coupling allows the fan to be driven in a normal manner. This is done at low engine speeds while limiting the top speed of the fan to a predetermined maximum level at higher engine speeds.

2.5L vehicles with A/C are equipped with a viscous fan drive which is designed to “free wheel” during most of the ambient conditions encountered by the vehicle and will only engage during high heat loads as seen in trailer towing or high ambient temperatures.

A thermostatic bimetallic spring coil is located on the front face of the viscous fan drive unit. A typical viscous unit is shown in (Fig. 13). This spring coil reacts to the temperature of the radiator discharge air. It engages the viscous fan drive for higher fan speed if the air temperature from the radiator rises above a certain point. Until additional engine cooling is necessary, the fan will remain at a reduced rpm regardless of engine speed.

Vehicles equipped with 2.5L engines have what is know as an hybrid cooling fan system. This means that not only do they have a viscous fan but they also have an electric fan as well. The hybrid viscous fan drive has a low speed characteristic. This causes the mechanical fan speeds to be very low 200–400 rpm range when not engaged allowing the engine to have additional performance and horsepower gains.

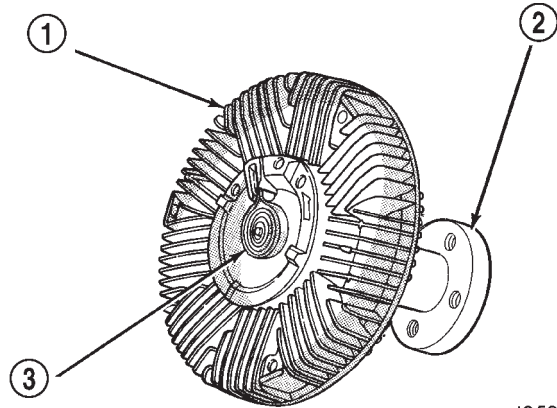

J9507-37

**Fig. 13 Typical Viscous Fan Drive**

- 1 - VISCOUS FAN DRIVE
- 2 - MOUNTING HUB
- 3 - THERMOSTATIC SPRING

OPERATION

Only when sufficient heat is present, will the viscous fan drive engage. This is when the air flowing through the radiator core causes a reaction to the bimetallic coil. It then increases fan speed to provide the necessary additional engine cooling.

Once the engine has cooled, the radiator discharge temperature will drop. The bimetallic coil again reacts and the fan speed is reduced to the previous disengaged speed.

## DESCRIPTION AND OPERATION (Continued)

## ELECTRIC COOLING FAN

## DESCRIPTION

Vehicles equipped with a 2.5L/4.0L engine and air conditioning and 4.0L vehicles equipped with the "max" cooling package also have an electrical cooling fan. The fan is controlled by the cooling fan relay, which is located in the power distribution center (PDC) (Fig. 15). For the location of relay within the PDC, refer to the label on PDC cover.

The electric fan on the 2.5L engine equipped vehicles is considered the primary fan (low to moderate ambient conditions) and is energized when the JTEC receives input from the coolant temperature sensor or the a/c system and supplies ground to the cooling fan relay.

The cooling fan motor is protected by a 40 amp maxi-fuse located in the PDC. The fan relay is protected by a 15 amp fuse located in the junction block.

## OPERATION

**Electric cooling fan 2.5L:** When air conditioning is not requested, the electric fan will not come on unless the coolant temperature is at least 103° C (218° F), at which time the fan will come on and remain on until the coolant temperature drops to 99° C (210° F) or below. When air conditioning is requested (including defroster operation), the fan will cycle on and off in conjunction with the A/C compressor unless the coolant temperature is at least 97° C (207° F), at which time the fan will come on and remain on until the coolant temperature drops to 93° C (199° F) or below. Then, the cycle fan operation will resume. When the fan is scheduled to be on, the powertrain control module (PCM) provides a ground path for the fan relay. This ground is provided to the cooling fan relay through pin C2 of PCM connector C3. Battery voltage is then applied to the fan through the relay. When the fan is scheduled to be off, the PCM opens the ground path to the relay. This will prevent the cooling fan from being energized.

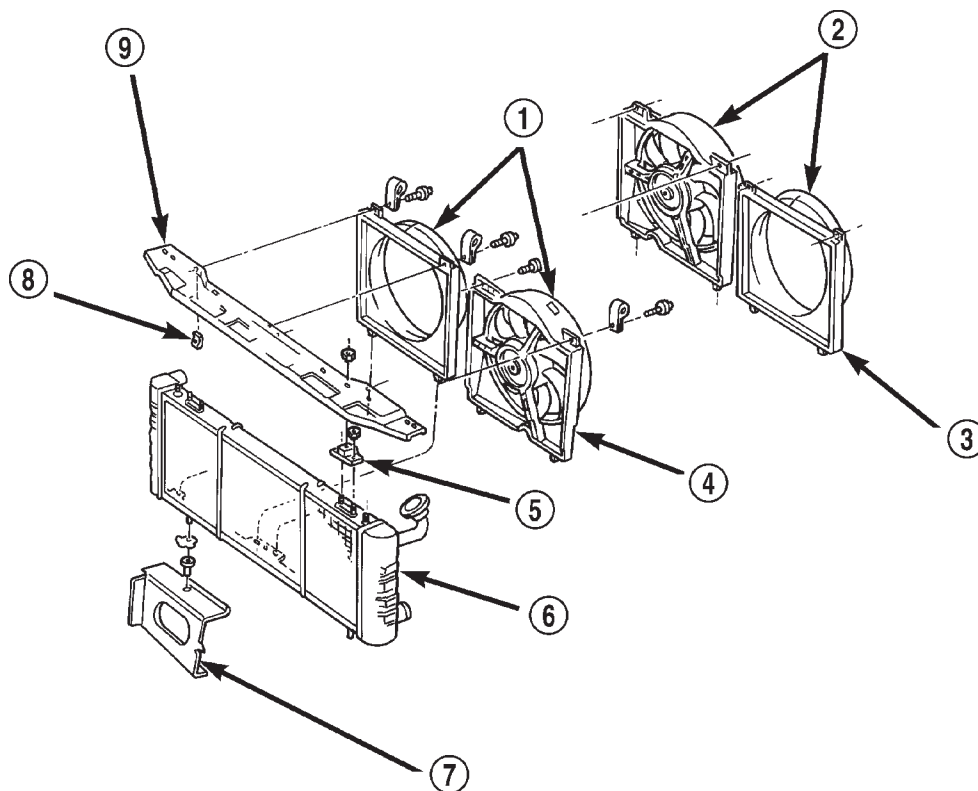

**Fig. 14 Electric Cooling Fan**

- |                         |                       |
|-------------------------|-----------------------|
| 1 - (LHD)               | 6 - RADIATOR          |
| 2 - (RHD)               | 7 - LOWER CROSSMEMBER |
| 3 - VISCOUS FAN SHROUD  | 8 - U-NUT             |
| 4 - ELECTRIC FAN MODULE | 9 - UPPER CROSSMEMBER |
| 5 - ISOLATOR            |                       |

80ae8364



DESCRIPTION AND OPERATION (Continued)

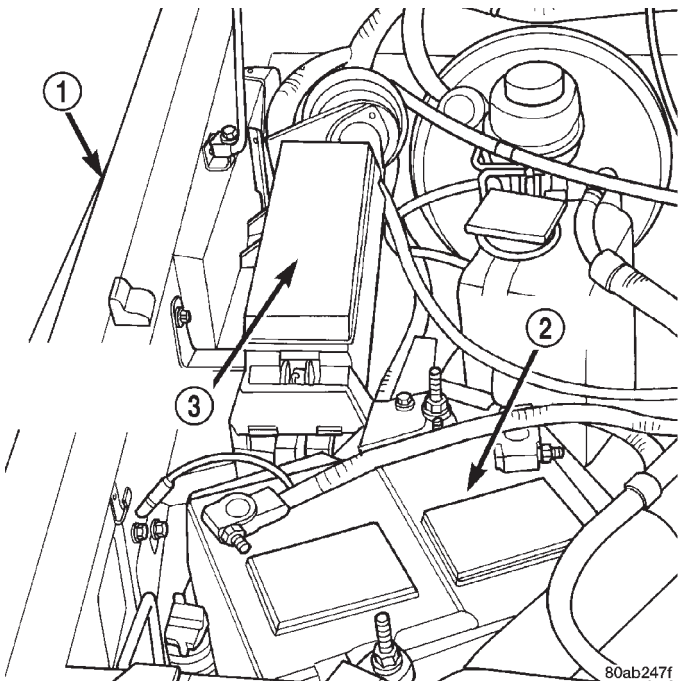

**Fig. 15 Power Distribution Center (PDC)**

- 1 - RIGHT FENDER
- 2 - BATTERY
- 3 - POWER DISTRIBUTION CENTER

**Electric cooling fan 4.0L:** With or without A/C request the electric fan will come on only when the coolant temperature is at least 106° C (223° F), and will remain on until the coolant temperature drops to 103° C (217° F) or below. Regardless of coolant temperature, When air conditioning system pressures reach 2068.5 ± 138 kPa (300 ± 20 psi) the electric fan will engage and continue to run until the A/C system pressure drops to 1620.3 kPa (235 psi) minimum, then the electric fan will shut off.

DIAGNOSIS AND TESTING

ON-BOARD DIAGNOSTICS (OBD)

COOLING SYSTEM RELATED DIAGNOSTICS

The Powertrain Control Module (PCM) has been programmed to monitor the certain following cooling system components:

- If the engine has remained cool for too long a period, such as with a stuck open thermostat, a Diagnostic Trouble Code (DTC) can be set.
- If an open or shorted condition has developed in the relay circuit controlling the electric radiator fan, a Diagnostic Trouble Code (DTC) can be set.

If the problem is sensed in a monitored circuit often enough to indicate an actual problem, a DTC is stored. The DTC will be stored in the PCM memory for eventual display to the service technician. (Refer

to Group 25, Emission Control Systems for proper procedures)

ACCESSING DIAGNOSTIC TROUBLE CODES

To read DTC's and to obtain cooling system data, refer to Group 25, Emission Control Systems for proper procedures.

DRB SCAN TOOL

For operation of the DRB scan tool, refer to the appropriate Powertrain Diagnostic Procedures service manual.

ACCESSORY DRIVE BELT DIAGNOSIS

VISUAL DIAGNOSIS

When diagnosing serpentine accessory drive belts, small cracks that run across the ribbed surface of the belt from rib to rib (Fig. 16), are considered normal. These are not a reason to replace the belt. However, cracks running along a rib (not across) are **not** normal. Any belt with cracks running along a rib must be replaced (Fig. 16). Also replace the belt if it has excessive wear, frayed cords or severe glazing.

Refer to the Accessory Drive Belt Diagnosis charts for further belt diagnosis.

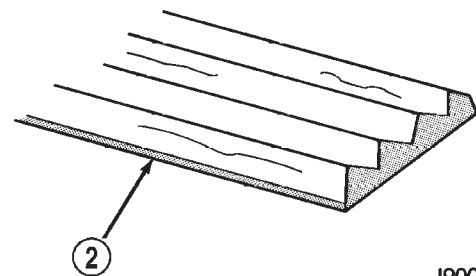
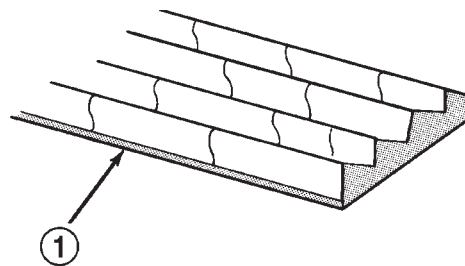

**Fig. 16 Belt Wear Patterns**

J9007-44

- 1 - NORMAL CRACKS BELT OK
- 2 - NOT NORMAL CRACKS REPLACE BELT

NOISE DIAGNOSIS

Noises generated by the accessory drive belt are most noticeable at idle. Before replacing a belt to resolve a noise condition, inspect all of the accessory drive pulleys for alignment, glazing, or excessive end play.

## DIAGNOSIS AND TESTING (Continued)

## ACCESSORY DRIVE BELT DIAGNOSIS CHART

CONDITION	POSSIBLE CAUSES	CORRECTION
RIB CHUNKING (One or more ribs has separated from belt body)	<ol style="list-style-type: none"> <li>1. Foreign objects imbedded in pulley grooves.</li> <li>2. Installation damage</li> </ol>	<ol style="list-style-type: none"> <li>1. Remove foreign objects from pulley grooves. Replace belt.</li> <li>2. Replace belt</li> </ol>
RIB OR BELT WEAR	<ol style="list-style-type: none"> <li>1. Pulley misaligned</li> <li>2. Abrasive environment</li> <li>3. Rusted pulley(s)</li> <li>4. Sharp or jagged pulley groove tips</li> <li>5. Belt rubber deteriorated</li> </ol>	<ol style="list-style-type: none"> <li>1. Align pulley(s)</li> <li>2. Clean pulley(s). Replace belt if necessary</li> <li>3. Clean rust from pulley(s)</li> <li>4. Replace pulley. Inspect belt.</li> <li>5. Replace belt</li> </ol>
BELT SLIPS	<ol style="list-style-type: none"> <li>1. Belt slipping because of insufficient tension</li> <li>2. Belt or pulley exposed to substance that has reduced friction (belt dressing, oil, ethylene glycol)</li> <li>3. Driven component bearing failure (seizure)</li> <li>4. Belt glazed or hardened from heat and excessive slippage</li> </ol>	<ol style="list-style-type: none"> <li>1. Adjust tension (2.5L)</li> <li>2. Replace belt and clean pulleys</li> <li>3. Replace faulty component or bearing</li> <li>4. Replace belt.</li> </ol>
LONGITUDAL BELT CRACKING	<ol style="list-style-type: none"> <li>1. Belt has mistracked from pulley groove</li> <li>2. Pulley groove tip has worn away rubber to tensile member</li> </ol>	<ol style="list-style-type: none"> <li>1. Replace belt</li> <li>2. Replace belt</li> </ol>
"GROOVE JUMPING" (Belt does not maintain correct position on pulley)	<ol style="list-style-type: none"> <li>1. Belt tension either too low or too high</li> <li>2. Pulley(s) not within design tolerance</li> <li>3. Foreign object(s) in grooves</li> <li>4. Pulley misalignment</li> <li>5. Belt cordline is broken</li> </ol>	<ol style="list-style-type: none"> <li>1. Adjust belt tension (2.5L)</li> <li>2. Replace pulley(s)</li> <li>3. Remove foreign objects from grooves</li> <li>4. Align component</li> <li>5. Replace belt</li> </ol>
BELT BROKEN (Note: Identify and correct problem before new belt is installed)	<ol style="list-style-type: none"> <li>1. Excessive tension</li> <li>2. Tensile member damaged during belt installation</li> <li>3. Severe misalignment</li> <li>4. Bracket, pulley, or bearing failure</li> </ol>	<ol style="list-style-type: none"> <li>1. Replace belt and adjust tension to specification</li> <li>2. Replace belt</li> <li>3. Align pulley(s)</li> <li>4. Replace defective component and belt</li> </ol>

DIAGNOSIS AND TESTING (Continued)

CONDITION	POSSIBLE CAUSES	CORRECTION
NOISE (Objectionable squeal, squeak, or rumble is heard or felt while drive belt is in operation)	<ol style="list-style-type: none"> <li>1. Belt slippage</li> <li>2. Bearing noise</li> <li>3. Belt misalignment</li> <li>4. Belt to pulley mismatch</li> <li>5. Driven component induced vibration</li> <li>6. System resonant frequency induced vibration</li> </ol>	<ol style="list-style-type: none"> <li>1. Adjust belt tension (2.5L)</li> <li>2. Locate and repair</li> <li>3. Align belt/pulley(s)</li> <li>4. Install correct belt</li> <li>5. Locate defective driven component and repair</li> <li>6. Vary belt tension within specifications.</li> </ol>
TENSION SHEETING FABRIC FAILURE (Woven fabric on outside, circumference of belt has cracked or separated from body of belt)	<ol style="list-style-type: none"> <li>1. Tension sheeting contacting stationary object</li> <li>2. Excessive heat causing woven fabric to age</li> <li>3. Tension sheeting splice has fractured</li> </ol>	<ol style="list-style-type: none"> <li>1. Correct rubbing condition</li> <li>2. Replace belt</li> <li>3. Replace belt</li> </ol>
CORD EDGE FAILURE (Tensile member exposed at edges of belt or separated from belt body)	<ol style="list-style-type: none"> <li>1. Excessive tension</li> <li>2. Belt contacting stationary object</li> <li>3. Pulley(s) out of tolerance</li> <li>4. Insufficient adhesion between tensile member and rubber matrix</li> </ol>	<ol style="list-style-type: none"> <li>1. Adjust belt tension (2.5L)</li> <li>2. Replace belt</li> <li>3. Replace pulley</li> <li>4. Replace belt and adjust tension to specifications</li> </ol>

**PRELIMINARY CHECKS**

**ENGINE COOLING SYSTEM OVERHEATING**

Establish what driving conditions caused the complaint. Abnormal loads on the cooling system such as the following may be the cause:

**PROLONGED IDLE, VERY HIGH AMBIENT TEMPERATURE, SLIGHT TAIL WIND AT IDLE, SLOW TRAFFIC, TRAFFIC JAMS, HIGH SPEED OR STEEP GRADES.**

Driving techniques that avoid overheating are:

- Idle with A/C off when temperature gauge is at end of normal range.
- Increasing engine speed for more air flow is recommended.

**TRAILER TOWING:**

Consult Trailer Towing section of owners manual. Do not exceed limits.

**AIR CONDITIONING; ADD-ON OR AFTER MARKET:**

A maximum cooling package should have been ordered with vehicle if add-on or after market A/C is installed. If not, maximum cooling system components should be installed for model involved per manufacturer's specifications.

**RECENT SERVICE OR ACCIDENT REPAIR:**

Determine if any recent service has been performed on vehicle that may effect cooling system. This may be:

- Engine adjustments (incorrect timing)
- Slipping engine accessory drive belt(s)
- Brakes (possibly dragging)
- Changed parts. Incorrect water pump or pump rotating in wrong direction due to belt not correctly routed
- Reconditioned radiator or cooling system refilling (possibly under filled or air trapped in system).

**NOTE: If investigation reveals none of the previous items as a cause for an engine overheating complaint, refer to following Cooling System Diagnosis charts.**

These charts are to be used as a quick-reference only. Refer to the group text for information.

## DIAGNOSIS AND TESTING (Continued)

## COOLING SYSTEM DIAGNOSIS CHART

CONDITION	POSSIBLE CAUSES	CORRECTION
TEMPERATURE GAUGE READS LOW	<ol style="list-style-type: none"> <li>1. Has a Diagnostic Trouble Code (DTC) been set indicating a stuck open thermostat?</li> <li>2. Is the temperature sending unit connected?</li> <li>3. Is the temperature gauge operating OK?</li> <li>4. Coolant level low in cold ambient temperatures accompanied with poor heater performance.</li> <li>5. Improper operation of internal heater doors or heater controls.</li> </ol>	<ol style="list-style-type: none"> <li>1. Refer to Group 25, Emission Systems for On-Board Diagnostics and DTC information. Replace thermostat if necessary.</li> <li>2. Check the temperature sensor connector. Refer to Group 8E. Repair connector if necessary.</li> <li>3. Check gauge operation. Refer to Group 8E. Repair as necessary.</li> <li>4. Check coolant level in the coolant reserve/overflow tank and the radiator. Inspect system for leaks. Repair leaks as necessary. Refer to the Coolant section of the manual text for WARNINGS and CAUTIONS associated with removing the radiator cap.</li> <li>5. Inspect heater and repair as necessary. Refer to Group 24, Heating and Air Conditioning for procedures.</li> </ol>
TEMPERATURE GAUGE READS HIGH OR THE COOLANT WARNING LAMP ILLUMINATES. COOLANT MAY OR MAY NOT BE LOST OR LEAKING FROM THE COOLING SYSTEM	<ol style="list-style-type: none"> <li>1. Trailer is being towed, a steep hill is being climbed, vehicle is operated in slow moving traffic, or engine is being idled with very high ambient (outside) temperatures and the air conditioning is on. Higher altitudes could aggravate these conditions.</li> <li>2. Is the temperature gauge reading correctly?</li> <li>3. Is the temperature warning illuminating unnecessarily?</li> <li>4. Coolant low in coolant reserve/overflow tank and radiator?</li> <li>5. Pressure cap not installed tightly. If cap is loose, boiling point of coolant will be lowered. Also refer to the following Step 6.</li> </ol>	<ol style="list-style-type: none"> <li>1. This may be a temporary condition and repair is not necessary. Turn off the air conditioning and attempt to drive the vehicle without any of the previous conditions. Observe the temperature gauge. The gauge should return to the normal range. If the gauge does not return to the normal range, determine the cause for overheating and repair. Refer to Possible Causes (2-20).</li> <li>2. Check gauge. Refer to Group 8E. Repair as necessary.</li> <li>3. Check warning lamp operation. Refer to Group 8E. Repair as necessary.</li> <li>4. Check for coolant leaks and repair as necessary. Refer to Testing Cooling System for Leaks in this Group.</li> <li>5. Tighten cap</li> </ol>

DIAGNOSIS AND TESTING (Continued)

CONDITION	POSSIBLE CAUSES	CORRECTION
<p>TEMPERATURE GAUGE READS HIGH OR THE COOLANT WARNING LAMP ILLUMINATES. COOLANT MAY OR MAY NOT BE LOST OR LEAKING FROM THE COOLING SYSTEM (CONTINUED)</p>	<p>6. Poor seals at the radiator cap.</p> <p>7. Coolant level low in radiator but not in coolant reserve/overflow tank. This means the radiator is not drawing coolant from the coolant reserve/overflow tank as the engine cools</p> <p>8. Incorrect coolant concentration</p> <p>9. Coolant not flowing through system</p> <p>10. Radiator or A/C condenser fins are dirty or clogged.</p> <p>11. Radiator core is corroded or plugged.</p> <p>12. Aftermarket A/C installed without proper radiator.</p> <p>13. Fuel or ignition system problems.</p> <p>14. Dragging brakes.</p> <p>15. Bug screen or cardboard is being used, reducing airflow.</p> <p>16. Thermostat partially or completely shut.</p>	<p>6. (a) Check condition of cap and cap seals. Refer to Radiator Cap. Replace cap if necessary.</p> <p>(b) Check condition of radiator filler neck. If neck is bent or damaged, replace radiator.</p> <p>7. (a) Check condition of radiator cap and cap seals. Refer to Radiator Cap in this Group. Replace cap if necessary.</p> <p>(b) Check condition of radiator filler neck. If neck is bent or damaged, replace radiator.</p> <p>(c) Check condition of the hose from the radiator to the coolant tank. It should fit tight at both ends without any kinks or tears. Replace hose if necessary.</p> <p>(d) Check coolant reserve/overflow tank and tanks hoses for blockage. Repair as necessary.</p> <p>8. Check coolant. Refer to Coolant section in this Group for correct coolant/water mixture ratio.</p> <p>9. Check for coolant flow at radiator filler neck with some coolant removed, engine warm and thermostat open. Coolant should be observed flowing through radiator. If flow is not observed, determine area of obstruction and repair as necessary.</p> <p>10. Remove insects and debris. Refer to Radiator Cleaning in this Group.</p> <p>11. Have radiator re-cored or replaced.</p> <p>12. Install proper radiator.</p> <p>13. Refer to Fuel and Ignition System Groups for diagnosis.</p> <p>14. Check and correct as necessary. Refer to Group 5, Brakes for correct procedures.</p> <p>15. Remove bug screen or cardboard.</p> <p>16. Check thermostat operation and replace as necessary. Refer to Thermostats in this Group.</p>



## DIAGNOSIS AND TESTING (Continued)

CONDITION	POSSIBLE CAUSES	CORRECTION
TEMPERATURE GAUGE READS HIGH OR THE COOLANT WARNING LAMP ILLUMINATES. COOLANT MAY OR MAY NOT BE LOST OR LEAKING FROM THE COOLING SYSTEM (CONTINUED)	<p>17. Viscous fan drive not operating properly.</p> <p>18. Electric cooling fan not operating properly (vehicles equipped with 2.5L/4.0L and air conditioning)</p> <p>19. Cylinder head gasket leaking.</p> <p>20. Heater core leaking.</p>	<p>17. Check fan drive operation and replace as necessary. Refer to Viscous Fan Drive in this Group.</p> <p>18. Check electric fan operation and repair as necessary. Refer to Electric Cooling Fan in this Group.</p> <p>19. Check for cylinder head gasket leaks. Refer to Cooling System-Testing For Leaks in this Group. For repair, refer to Group 9, Engines.</p> <p>20. Check heater core for leaks. Refer to Group 24, Heating and Air Conditioning. Repair as necessary.</p>
TEMPERATURE GAUGE READING IS INCONSISTENT (FLUCTUATES, CYCLES OR IS ERRATIC)	<p>1. On vehicles equipped with an electric fan, the gauge may cycle up and down. This is due to the cycling of the electric radiator fan.</p> <p>2. During cold weather operation, with the heater blower in the high position, the gauge reading may drop slightly.</p> <p>3. Temperature gauge or engine mounted gauge sensor defective or shorted. Also, corroded or loose wiring in this circuit.</p> <p>4. Gauge reading rises when vehicle is brought to a stop after heavy use (engine still running)</p> <p>5. Gauge reading high after re-starting a warmed up (hot) engine.</p> <p>6. Coolant level low in radiator (air will build up in the cooling system causing the thermostat to open late).</p> <p>7. Cylinder head gasket leaking allowing exhaust gas to enter cooling system causing a thermostat to open late.</p>	<p>1. This is a normal condition. No correction is necessary unless the gauge cycles into the red (overheat) zone. Refer to Electric Cooling Fan Diagnosis and Testing in this group.</p> <p>2. A normal condition. No correction is necessary.</p> <p>3. Check operation of gauge and repair if necessary. Refer to Group 8E, Instrument Panel and Gauges.</p> <p>4. A normal condition. No correction is necessary. Gauge should return to normal range after vehicle is driven.</p> <p>5. A normal condition. No correction is necessary. The gauge should return to normal range after a few minutes of engine operation.</p> <p>6. Check and correct coolant leaks. Refer to Cooling System-Testing for leaks in this group.</p> <p>7. (a) Check for cylinder head gasket leaks. Refer to Cooling System-Testing for Leaks in this group.</p> <p>(b) Check for coolant in the engine oil. Inspect for white steam emitting from the exhaust system. Repair as necessary.</p>

DIAGNOSIS AND TESTING (Continued)

CONDITION	POSSIBLE CAUSES	CORRECTION
TEMPERATURE GAUGE READING IS INCONSISTENT (FLUCTUATES, CYCLES OR IS ERRATIC) (CONTINUED)	8. Water pump impeller loose on shaft.  9. Loose accessory drive belt. (water pump slipping)  10. Air leak on the suction side of the water pump allows air to build up in cooling system causing thermostat to open late.	8. Check water pump and replace as necessary. Refer to water Pumps in this group.  9. Refer to Accessory Drive Belts in this group. Check and correct as necessary.  10. Locate leak and repair as necessary.
PRESSURE CAP IS BLOWING OFF STEAM AND/OR COOLANT TO COOLANT TANK. TEMPERATURE GAUGE READING MAY BE ABOVE NORMAL BUT NOT HIGH. COOLANT LEVEL MAY BE HIGH IN COOLANT RESERVE/OVERFLOW TANK	1. Pressure relief valve in radiator cap is defective.	1. Check condition of radiator cap and cap seals. Refer to Radiator Caps in this group. Replace cap as necessary.
COOLANT LOSS TO THE GROUND WITHOUT PRESSURE CAP BLOWOFF. GAUGE READING HIGH OR HOT	1. Coolant leaks in radiator, cooling system hoses, water pump or engine.	1. Pressure test and repair as necessary. Refer to Cooling System-Testing For Leaks in this group.
DETONATION OR PRE-IGNITION (NOT CAUSED BY IGNITION SYSTEM). GAUGE MAY OR MAY NOT BE READING HIGH	1. engine overheating.  2. Freeze point of coolant not correct. Mixture is too rich or too lean.	1. Check reason for overheating and repair as necessary.  2. Check coolant concentration. Refer to the Coolant section of this group and adjust ratio as required.
HOSE OR HOSES COLLAPSE WHILE ENGINE IS RUNNING	1. Vacuum created in cooling system on engine cool-down is not being relieved through coolant reserve/overflow system.	1. (a) Radiator cap relief valve stuck. Refer to Radiator Cap in this group. Replace if necessary  (b) Hose between coolant reserve/overflow tank and radiator is kinked. Repair as necessary.  (c) Vent at coolant reserve/overflow tank is plugged. Clean vent and repair as necessary.  (d) Reserve/overflow tank is internally blocked or plugged. Check for blockage and repair as necessary.
ELECTRIC RADIATOR FAN RUNS ALL OF THE TIME (2.5L/4.0L MODELS EQUIPPED WITH A/C AND 4.0L MODELS EQUIPPED WITH MAX COOLING)	1. Fan relay, powertrain control module (PCM) or coolant temperature sensor defective.	1. Refer to Electric Cooling Fan Diagnosis and Testing. Also refer to Group 8W, Wiring Diagrams. Repair as necessary.

## DIAGNOSIS AND TESTING (Continued)

CONDITION	POSSIBLE CAUSES	CORRECTION
ELECTRIC RADIATOR FAN WILL NOT RUN AT ALL. GAUGE READING HIGH OR HOT (2.5L/4.0L MODELS EQUIPPED WITH A/C AND 4.0L MODELS EQUIPPED WITH MAX COOLING)	<ol style="list-style-type: none"> <li>1. Blown Fuse in Power Distribution Center (PDC)</li> <li>2. Fan relay, powertrain control module (PCM) or coolant temperature sensor defective.</li> <li>3. Fan Motor Defective</li> </ol>	<ol style="list-style-type: none"> <li>1. Determine reason for blown fuse and repair as necessary.</li> <li>2. Refer to Electric Cooling Fan Diagnosis and Testing. Also refer to Group 8W, Wiring Diagrams. Repair as necessary.</li> <li>3. Refer to Electric Cooling Fan Diagnosis and Testing. Also refer to Group 8W, Wiring Diagrams. Repair as necessary.</li> </ol>
NOISY VISCOUS FAN/DRIVE	<ol style="list-style-type: none"> <li>1. Fan blades loose.</li> <li>2. Fan blades striking a surrounding object.</li> <li>3. Air obstructions at radiator or air conditioning condenser.</li> <li>4. Thermal viscous fan drive has defective bearing.</li> <li>5. A certain amount of fan noise may be evident on models equipped with a thermal viscous fan drive. Some of this noise is normal.</li> </ol>	<ol style="list-style-type: none"> <li>1. Replace fan blade assembly. Refer to Cooling System Fans in this Group</li> <li>2. Locate point of fan blade contact and repair as necessary.</li> <li>3. Remove obstructions and/or clean debris or insects from radiator or A/C condenser.</li> <li>4. Replace fan drive. Bearing is not serviceable. Refer to Viscous Fan Drive in this group.</li> <li>5. Refer to Viscous Fan Drive in this group for an explanation of normal fan noise.</li> </ol>
INADEQUATE HEATER PERFORMANCE. THERMOSTAT FAILED IN OPEN POSITION	<ol style="list-style-type: none"> <li>1. Has a Diagnostic trouble Code (DTC) been set?</li> <li>2. Coolant level low</li> <li>3. Obstructions in heater hose/ fittings</li> <li>4. Heater hose kinked</li> <li>5. Water pump is not pumping water to/through the heater core. When the engine is fully warmed up, both heater hoses should be hot to the touch. If only one of the hoses is hot, the water pump may not be operating correctly or the heater core may be plugged. Accessory drive belt may be slipping causing poor water pump operation.</li> </ol>	<ol style="list-style-type: none"> <li>1. Refer to Group 25, Emissions for correct procedures and replace thermostat if necessary</li> <li>2. Refer to Cooling System-Testing For Leaks in this group.</li> <li>3. Remove heater hoses at both ends and check for obstructions</li> <li>4. Locate kinked area and repair as necessary</li> <li>5. Refer to Water Pump in this group. If a slipping belt is detected, refer to Accessory Drive Belts in this group. If heater core obstruction is detected, refer to Group 24, Heating and Air Conditioning.</li> </ol>

DIAGNOSIS AND TESTING (Continued)

CONDITION	POSSIBLE CAUSES	CORRECTION
STEAM IS COMING FROM THE FRONT OF VEHICLE NEAR THE GRILL AREA WHEN WEATHER IS WET, ENGINE IS WARMED UP AND RUNNING, AND VEHICLE IS STATIONARY. TEMPERATURE GAUGE IS IN NORMAL RANGE	1. During wet weather, moisture (snow, ice or rain condensation) on the radiator will evaporate when the thermostat opens. This opening allows heated water into the radiator. When the moisture contacts the hot radiator, steam may be emitted. This usually occurs in cold weather with no fan or airflow to blow it away.	1. Occasional steam emitting from this area is normal. No repair is necessary.
COOLANT COLOR	1. Coolant color is not necessarily an indication of adequate corrosion or temperature protection. Do not rely on coolant color for determining condition of coolant.	1. Refer to Coolant in this group for coolant concentration information. Adjust coolant mixture as necessary.
COOLANT LEVEL CHANGES IN COOLANT RESERVE/OVERFLOW TANK. TEMPERATURE GAUGE IS IN NORMAL RANGE	1. Level changes are to be expected as coolant volume fluctuates with engine temperature. If the level in the tank was between the FULL and ADD marks at normal operating temperature, the level should return to within that range after operation at elevated temperatures.	1. A normal condition. No repair is necessary.

**RADIATOR COOLANT FLOW CHECK**

The following procedure will determine if coolant is flowing through the cooling system.

If engine is cold, idle engine until normal operating temperature is reached. Then feel the upper radiator hose. If hose is hot, the thermostat is open and water is circulating through cooling system.

**COOLING SYSTEM—TESTING FOR LEAKS**

**ULTRAVIOLET LIGHT METHOD**

All Jeep models have a leak detection additive added to the cooling system before they leave the factory. The additive is highly visible under ultraviolet light (black light). If the factory original coolant has been drained, pour one ounce of additive into the cooling system. The additive is available through the part's department. Place the heater control unit in HEAT position. Start and operate the engine until the radiator upper hose is warm to the touch. Aim the commercially available black light tool at the components to be checked. If leaks are present, the black light will cause the additive to glow a bright green color.

The black light can be used along with a pressure tester to determine if any external leaks exist (Fig. 17).

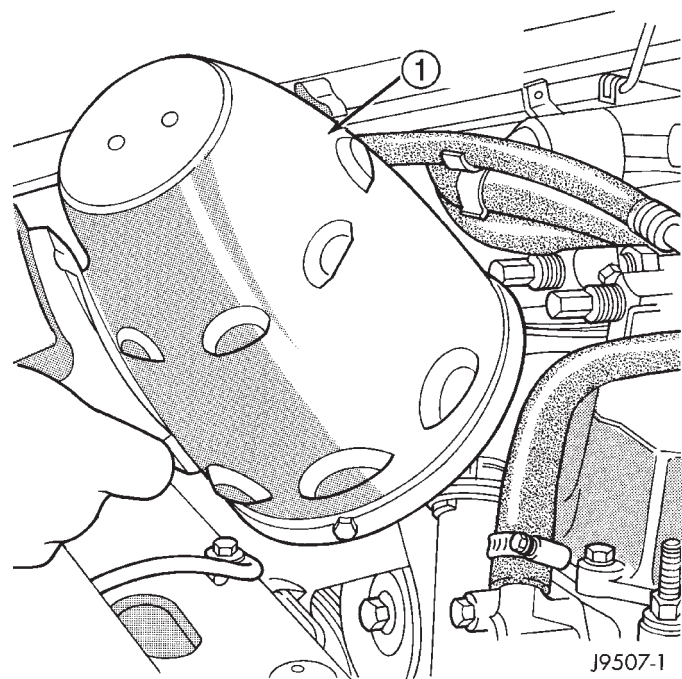

J9507-1

**Fig. 17 Leak Detection Using Black Light—Typical**  
1 – TYPICAL BLACK LIGHT TOOL

## DIAGNOSIS AND TESTING (Continued)

**PRESSURE TESTER METHOD**

The engine should be at the normal operating temperature. Recheck the system cold if the cause of coolant loss is not located during warm engine examination.

**WARNING: HOT, PRESSURIZED COOLANT CAN CAUSE INJURY BY SCALDING.**

Carefully remove the radiator pressure cap from the filler neck and check the coolant level. Push down on the cap to disengage it from the stop tabs. Wipe the inner part of the filler neck and examine the lower inside sealing seat for nicks, cracks, paint, dirt and solder residue. Inspect the reserve/overflow tank tube for internal obstructions. Insert a wire through the tube to be sure it is not obstructed.

Inspect the cams on the outside part of the filler neck. If the cams are bent, seating of pressure cap valve and tester seal will be affected. Replace cap if cams are bent.

Attach pressure tester 7700 (or an equivalent) to the radiator filler neck (Fig. 18).

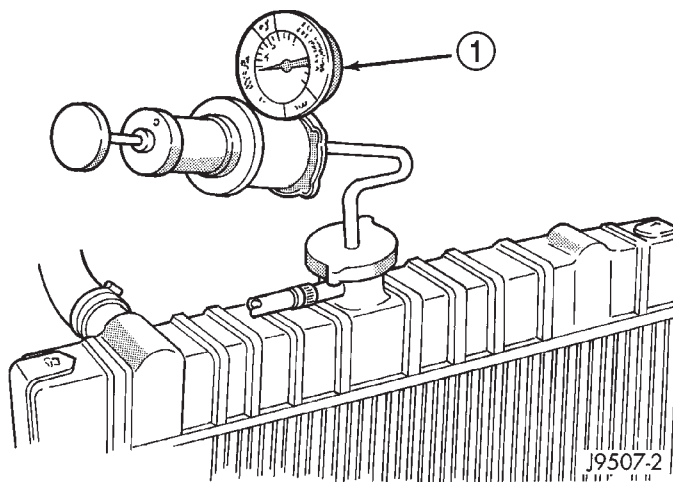

**Fig. 18 Pressurizing System—Typical**

1 - TYPICAL COOLING SYSTEM PRESSURE TESTER

Operate the tester pump to apply 124 kPa (18 psi) pressure to the system. If the hoses enlarge excessively or bulge while testing, replace as necessary. Observe the gauge pointer and determine the condition of the cooling system according to the following criteria:

- **Holds Steady:** If the pointer remains steady for two minutes, there are no serious coolant leaks in the system. However, there could be an internal leak that does not appear with normal system test pressure. Inspect for interior leakage or do the Internal Leakage Test. Do this if it is certain that coolant is being lost and no leaks can be detected.

- **Drops Slowly:** Shows a small leak or seepage is occurring. Examine all connections for seepage or slight leakage with a flashlight. Inspect the radiator, hoses, gasket edges and heater. Seal any small leak holes with a Sealer Lubricant or equivalent. Repair leak holes and reinspect the system with pressure applied.

- **Drops Quickly:** Shows that a serious leakage is occurring. Examine the system for serious external leakage. If no leaks are visible, inspect for internal leakage. Large radiator leak holes should be repaired by a reputable radiator repair shop.

**INTERNAL LEAKAGE INSPECTION**

Remove the engine oil pan drain plug and drain a small amount of engine oil. Coolant, being heavier than engine oil, will drain first. Another way of testing is to operate the engine and check for water globules on the engine oil dipstick. Also inspect the automatic transmission oil dipstick for water globules. Inspect the automatic transmission fluid cooler for leakage. Operate the engine without the pressure cap on the radiator until thermostat opens.

Attach a pressure tester to the filler neck. If pressure builds up quickly, a leak exists as a result of a faulty cylinder head gasket or crack in the engine. Repair as necessary.

**WARNING: DO NOT ALLOW PRESSURE TO EXCEED 124 KPA (18 PSI). TURN THE ENGINE OFF. TO RELEASE THE PRESSURE, ROCK THE TESTER FROM SIDE TO SIDE. WHEN REMOVING THE TESTER, DO NOT TURN THE TESTER MORE THAN 1/2 TURN IF THE SYSTEM IS UNDER PRESSURE.**

If there is no immediate pressure increase, pump the pressure tester until the indicated pressure is within the system range. Vibration of the gauge pointer indicates compression or combustion leakage into the cooling system.

**WARNING: DO NOT DISCONNECT THE SPARK PLUG WIRES WHILE THE ENGINE IS OPERATING.**

**CAUTION: Do not operate the engine with a spark plug shorted for more than a minute. The catalytic converter may be damaged.**

Isolate the compression leak by shorting each spark plug to the cylinder block. The gauge pointer should stop or decrease vibration when spark plug for leaking cylinder is shorted. This happens because of the absence of combustion pressure.



## DIAGNOSIS AND TESTING (Continued)

**COMBUSTION LEAKAGE TEST (WITHOUT PRESSURE TESTER)**

DO NOT WASTE reusable coolant. If the solution is clean, drain the coolant into a clean container for reuse.

**WARNING: DO NOT REMOVE THE CYLINDER BLOCK DRAIN PLUGS OR LOOSEN THE RADIATOR DRAINCOCK WITH THE SYSTEM HOT AND UNDER PRESSURE. SERIOUS BURNS FROM COOLANT CAN OCCUR.**

Drain sufficient coolant to allow for thermostat removal. Refer to Thermostat Replacement. Disconnect the water pump drive belt.

Disconnect the upper radiator hose from the thermostat housing. Remove the housing and thermostat. Install the thermostat housing.

Add coolant to the radiator to bring the level to within 6.3 mm (1/4 in) of the top of the thermostat housing.

**CAUTION: Avoid overheating. Do not operate the engine for an excessive period of time. Open the draincock immediately after the test to eliminate boil over of coolant.**

Start the engine and accelerate rapidly three times (to approximately 3000 rpm) while observing the coolant. If internal engine combustion gases are leaking into the cooling system, bubbles will appear in the coolant. If bubbles do not appear, there is no internal combustion gas leakage.

**VISCOUS FAN DRIVE****LEAKS**

Viscous fan drive operation is not affected by small oil stains near the drive bearing. If leakage appears excessive, replace the fan drive unit.

**TESTING**

If the fan assembly free-wheels without drag (the fan blades will revolve more than five turns when spun by hand), replace the fan drive. This spin test must be performed when the engine is cool.

For the following test, the cooling system must be in good condition. It also will ensure against excessively high coolant temperature.

**WARNING: BE SURE THAT THERE IS ADEQUATE FAN BLADE CLEARANCE BEFORE DRILLING.**

(1) Drill a 3.18-mm (1/8-in) diameter hole in the top center of the fan shroud.

(2) Obtain a dial thermometer with an 8 inch stem (or equivalent). It should have a range of -18°-to-

105°C (0°-to-220° F). Insert thermometer through the hole in the shroud. Be sure that there is adequate clearance from the fan blades.

(3) Connect a tachometer and an engine ignition timing light (timing light is to be used as a strobe light).

(4) Block the air flow through the radiator. Secure a sheet of plastic in front of the radiator (or air conditioner condenser). Use tape at the top to secure the plastic and be sure that the air flow is blocked.

(5) Be sure that the air conditioner (if equipped) is turned off.

**WARNING: USE EXTREME CAUTION WHEN THE ENGINE IS OPERATING. DO NOT STAND IN A DIRECT LINE WITH THE FAN. DO NOT PUT YOUR HANDS NEAR THE PULLEYS, BELTS OR FAN. DO NOT WEAR LOOSE CLOTHING.**

(6) Start the engine and operate at 2400 rpm. Within ten minutes the air temperature (indicated on the dial thermometer) should be up to 88° C (190° F). Fan drive **engagement** should have started to occur at between 74° to 82° C (165° to 180° F). Engagement is distinguishable by a definite **increase** in fan flow noise (roaring). The timing light also will indicate an increase in the speed of the fan.

(7) When the air temperature reaches 88° C (190° F), remove the plastic sheet. Fan drive **disengagement** should have started to occur at between 57° to 79° C (135° to 175° F). A definite **decrease** of fan flow noise (roaring) should be noticed. If not, replace the defective viscous fan drive unit.

**ELECTRIC COOLING FAN****ELECTRIC COOLING FAN AND RELAY DIAGNOSIS**

**NOTE: Refer to Electrical Group 8W for electric cooling fan and relay circuit schematic.**

The powertrain control module (PCM) will enter a diagnostic trouble code (DTC) in memory if it detects a problem in the auxiliary cooling fan relay or circuit. Refer to Group 25, Emission Control Systems for correct DTC retrieval procedures.

If the electric cooling fan is inoperative, check the 15A fuse in the junction block and the 40A fuse in the Power Distribution Center (PDC) with a 12 volt test lamp or DVOM. Refer to the inside of the PDC cover for the exact location of the fuse. If fuses are o.k., refer to Group 8W for electric cooling fan and relay circuit schematic.

## DIAGNOSIS AND TESTING (Continued)

**RADIATOR CAP-TO-FILLER NECK SEAL—  
PRESSURE RELIEF CHECK**

With radiator cap installed on filler neck, remove coolant reserve/ overflow tank hose from nipple on filler neck. Connect a hand operated vacuum pump to nipple. Operate pump until a reading of 47-to-61 kPa (14- to-18 in. Hg) appears on gauge. If the reading stays steady, or drops slightly and then remains steady, the pressure valve seal is good. Replace radiator cap if reading does not hold.

**WARNING: THE WARNING WORDS -DO NOT OPEN HOT- ON THE RADIATOR PRESSURE CAP (Fig. 19) ARE A SAFETY PRECAUTION. WHEN HOT, PRESSURE BUILDS UP IN COOLING SYSTEM. TO PREVENT SCALDING OR INJURY, THE RADIATOR CAP SHOULD NOT BE REMOVED WHILE THE SYSTEM IS HOT AND/OR UNDER PRESSURE.**

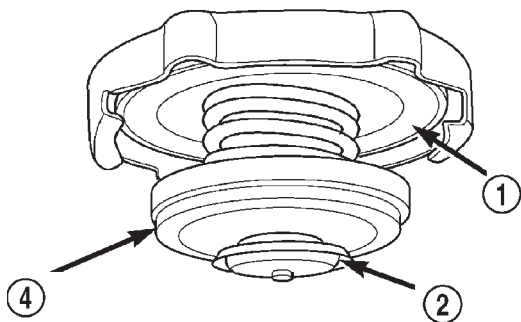
CROSS-SECTIONAL VIEWTOP VIEW

80bfe12f

**Fig. 19 Radiator Pressure Cap**

- 1 - FILLER NECK SEAL
- 2 - VACUUM VENT VALVE
- 3 - PRESSURE RATING
- 4 - PRESSURE VALVE

There is no need to remove the radiator cap **except** for the following purposes:

- (1) To check and adjust antifreeze freeze point.
- (2) To refill system with new antifreeze.
- (3) For conducting service procedures.
- (4) When checking for vacuum leaks.

**WARNING: IF VEHICLE HAS BEEN RUN RECENTLY, WAIT AT LEAST 15 MINUTES BEFORE REMOVING RADIATOR CAP. WITH A RAG, SQUEEZE RADIATOR UPPER HOSE TO CHECK IF SYSTEM IS UNDER PRESSURE. PLACE A RAG OVER THE CAP AND WITHOUT PUSHING DOWN, ROTATE CAP COUNTER-CLOCKWISE TO THE FIRST STOP. ALLOW FLUID TO ESCAPE THROUGH OVERFLOW HOSE INTO COOLANT RESERVE/OVERFLOW TANK. SQUEEZE RADIATOR UPPER HOSE TO DETERMINE WHEN PRESSURE HAS BEEN RELEASED. WHEN COOLANT AND STEAM STOP BEING PUSHED INTO TANK AND SYSTEM PRESSURE DROPS, REMOVE RADIATOR CAP COMPLETELY.**

**RADIATOR CAP—PRESSURE TESTING**

Remove cap from radiator. Be sure that sealing surfaces are clean. Moisten rubber gasket with water and install the cap on pressure tester (tool 7700 or an equivalent) (Fig. 20).

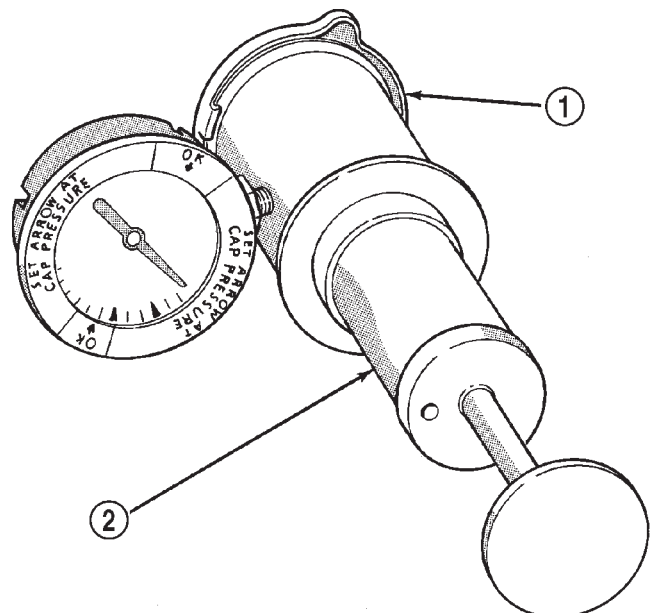

J9507-3

**Fig. 20 Pressure Testing Radiator Pressure Cap—Typical**

- 1 - PRESSURE CAP
- 2 - TYPICAL COOLING SYSTEM PRESSURE TESTER

## DIAGNOSIS AND TESTING (Continued)

Operate the tester pump and observe the gauge pointer at its highest point. The cap release pressure should be 83-to-110 kPa (12-to-16 psi). The cap is satisfactory when the pressure holds steady. It is also good if it holds pressure within the 83-to-110 kPa (12-to-16 psi) range for 30 seconds or more. If the pointer drops quickly, replace the cap.

**CAUTION:** Radiator pressure testing tools are very sensitive to small air leaks, which will not cause cooling system problems. A pressure cap that does not have a history of coolant loss should not be replaced just because it leaks slowly when tested with this tool. Add water to tool. Turn tool upside down and recheck pressure cap to confirm that cap needs replacement.

### CAP INSPECTION

Visually inspect the pressure valve gasket on the cap. Replace cap if the gasket is swollen, torn or worn. Inspect the area around radiator filler neck for white deposits that indicate a leaking cap.

### COOLANT—LOW LEVEL AERATION

If the coolant level in radiator drops below top of radiator core tubes, air will enter cooling system.

Low coolant level can cause thermostat pellet to be suspended in air instead of coolant. This will cause thermostat to open later, which in turn causes higher coolant temperature. Air trapped in cooling system also reduces amount of coolant circulating in heater core resulting in low heat output.

### DEAERATION

As the engine operates, any air trapped in cooling system gathers under the radiator cap. The next time the engine is operated, thermal expansion of coolant will push any trapped air past radiator cap into the coolant reserve/overflow tank. Here it escapes to the atmosphere into the tank. When the engine cools down the coolant, it will be drawn from the reserve/overflow tank into the radiator to replace any removed air.

## SERVICE PROCEDURES

### COOLANT—ROUTINE LEVEL CHECK

**NOTE:** Do not remove radiator cap for routine coolant level inspections. The coolant level can be checked at coolant reserve/overflow tank.

The coolant reserve/overflow system provides a quick visual method for determining coolant level without removing radiator pressure cap. With engine cold and not running, observe coolant level in reserve/overflow tank. The coolant level should be between ADD and FULL marks.

### COOLANT—ADDING ADDITIONAL

**Do not remove radiator cap to add coolant to system.** When adding coolant to maintain correct level, do so at coolant reserve/overflow tank. Use a 50/50 mixture of ethylene-glycol antifreeze containing Alugard 340-2 <sup>™</sup> and low mineral content water. Remove radiator cap only for testing or when refilling system after service. Removing cap unnecessarily can cause loss of coolant and allow air to enter system, which produces corrosion.

### COOLANT—LEVEL CHECK

The cooling system is closed and designed to maintain coolant level to top of radiator.

**WARNING: DO NOT OPEN RADIATOR DRAINCOCK WITH ENGINE RUNNING OR WHILE ENGINE IS HOT AND COOLING SYSTEM IS UNDER PRESSURE.**

When vehicle servicing requires a coolant level check in radiator, drain several ounces of coolant from radiator drain cock. Do this while observing coolant reserve/overflow system tank. The coolant level in reserve/overflow tank should drop slightly. If not, inspect for a leak between radiator and coolant reserve/overflow system connection. Remove radiator cap. The coolant level should be to top of radiator. If not and if coolant level in reserve/overflow tank is at ADD mark, check for:

- An air leak in coolant reserve/overflow tank or its hose
- An air leak in radiator filler neck
- Leak in pressure cap seal to radiator filler neck

## COOLING SYSTEM—DRAINING AND FILLING

### DRAINING

**WARNING: DO NOT REMOVE THE CYLINDER BLOCK DRAIN PLUGS OR LOOSEN THE RADIATOR DRAINCOCK WITH SYSTEM HOT AND UNDER PRESSURE. SERIOUS BURNS FROM COOLANT CAN OCCUR.**

DO NOT WASTE reusable coolant. If the solution is clean, drain the coolant into a clean container for reuse.

- (1) Remove radiator pressure cap.

## SERVICE PROCEDURES (Continued)

(2) For access to radiator draincock (Fig. 21), remove radiator grille mounting screws and remove grille. Refer to Group 23, Body for correct procedure.

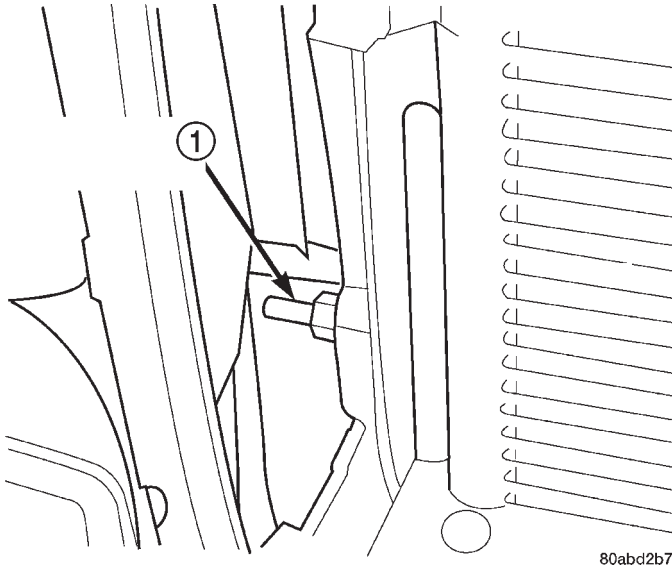

80abd2b7

**Fig. 21 Radiator Petcock—2.5L/4.0L (LHD/RHD)**

1 - RADIATOR PETCOCK

(3) Attach one end of a 24 inch long X 1/4 inch ID hose to the radiator draincock. Put the other end into a clean container. Open draincock and drain coolant from radiator.

(4) Drain coolant from engine by removing the drain plug and coolant temperature sensor on left side of block.

### REFILLING

(1) Tighten the radiator petcock and the cylinder block drain plug(s).

(2) Install grille.

(3) Fill system using a 50/50 mixture of water and antifreeze as described in the Coolant section of this group. Fill radiator to top and install radiator cap. Add sufficient coolant to reserve/overflow tank to raise level to FULL mark.

(4) With heater control unit in the HEAT position, operate engine with radiator cap in place.

(5) After engine has reached normal operating temperature, shut engine off and allow it to cool.

(6) Add coolant to reserve/overflow tank as necessary. **Only add coolant when the engine is cold. Coolant level in a warm engine will be higher due to thermal expansion.**

### COOLING SYSTEM—REVERSE FLUSHING

**CAUTION:** The cooling system normally operates at 97-to-124 kPa (14- to-18 psi) pressure. Exceeding this pressure may damage the radiator or hoses.

Reverse flushing of the cooling system is the forcing of water through the cooling system. This is done using air pressure in the opposite direction of normal coolant flow. It is usually only necessary with very dirty systems with evidence of partial plugging.

### CHEMICAL CLEANING

If visual inspection indicates the formation of sludge or scaly deposits, use a radiator cleaner (Mopar Radiator Kleen or equivalent) before flushing. This will soften scale and other deposits and aid the flushing operation.

**CAUTION:** Be sure instructions on the container are followed.

### REVERSE FLUSHING RADIATOR

Disconnect the radiator hoses from the radiator fittings. Attach a section of radiator hose to the radiator bottom outlet fitting and insert the flushing gun. Connect a water supply hose and air supply hose to the flushing gun.

**CAUTION:** The cooling system normally operates at 97-to-124 kPa (14- to-18 psi) pressure. Exceeding this pressure may damage the radiator or hoses.

Allow the radiator to fill with water. When radiator is filled, apply air in short blasts allowing radiator to refill between blasts. Continue this reverse flushing until clean water flows out through rear of radiator cooling tube passages. For more information, refer to operating instructions supplied with flushing equipment. Have radiator cleaned more extensively by a radiator repair shop.

### REVERSE FLUSHING ENGINE

Drain the cooling system. Remove the thermostat housing and thermostat. Install the thermostat housing. Disconnect the radiator upper hose from the radiator and attach the flushing gun to the hose. Disconnect the radiator lower hose from the water pump. Attach a lead away hose to the water pump inlet fitting.

**CAUTION:** Be sure that the heater control valve is closed (heat off). This is done to prevent coolant flow with scale and other deposits from entering the heater core.

Connect the water supply hose and air supply hose to the flushing gun. Allow the engine to fill with water. When the engine is filled, apply air in short blasts, allowing the system to fill between air blasts. Continue until clean water flows through the lead away hose. For more information, refer to operating instructions supplied with flushing equipment.



SERVICE PROCEDURES (Continued)

Remove the lead away hose, flushing gun, water supply hose and air supply hose. Remove the thermostat housing and install thermostat. Install the thermostat housing with a replacement gasket. Refer to Thermostat Replacement. Connect the radiator hoses. Refill the cooling system with the correct anti-freeze/water mixture.

REMOVAL AND INSTALLATION

TRANSMISSION OIL COOLERS

WATER-TO-OIL COOLER

The internal transmission oil cooler located within the radiator is not serviceable. If it requires service, the radiator must be replaced.

Once the repaired or replacement radiator has been installed, fill the cooling system and inspect for leaks. Refer to the Refilling Cooling System and Testing Cooling System For Leaks sections in this group. If the transmission operates properly after repairing the leak, drain the transmission and remove the transmission oil pan. Inspect for sludge and/or rust. Inspect for a dirty or plugged inlet filter. If none of these conditions are found, the transmission and torque convertor may not require reconditioning. Refer to Group 21 for automatic transmission servicing.

AIR-TO-OIL COOLER

REMOVAL

- (1) Remove the grill mounting screws and remove the grill. Refer to Group 23, Body for procedures.
- (2) Place a drain pan below the transmission oil cooler.
- (3) Remove the two constant tension clamps at oil cooler inlet and outlet tubes.
- (4) Remove the two oil cooler mounting bolts (Fig. 22).
- (5) Remove the oil cooler from vehicle.

INSTALLATION

- (1) Position and secure oil cooler to vehicle. Tighten mounting bolts to 8 N·m (72 in. lbs.) torque.
  - (2) Secure inlet and outlet tubes with constant tension clamps.
- Install the grill.
- (3) Start engine and check transmission fluid level. Add fluid if necessary.

COOLANT RESERVE TANK

REMOVAL

- (1) Remove the tube clamp at the tank and remove tube.

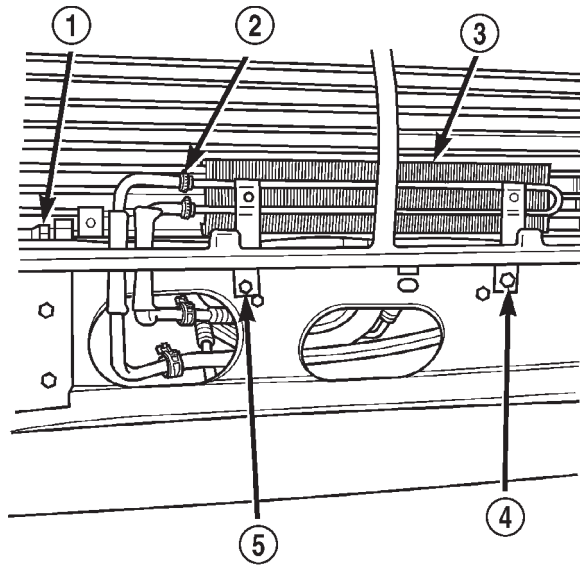

Fig. 22 Auxiliary Air-To-Oil Cooler

80be4561

- 1 - AIR CONDITIONING CONDENSER
- 2 - HOSE CLAMPS (2)
- 3 - AUXILIARY AUTOMATIC TRANSMISSION OIL COOLER
- 4 - MOUNTING BOLT
- 5 - MOUNTING BOLT

(2) Remove the tank mounting bolts and remove tank (Fig. 23) (Fig. 24).

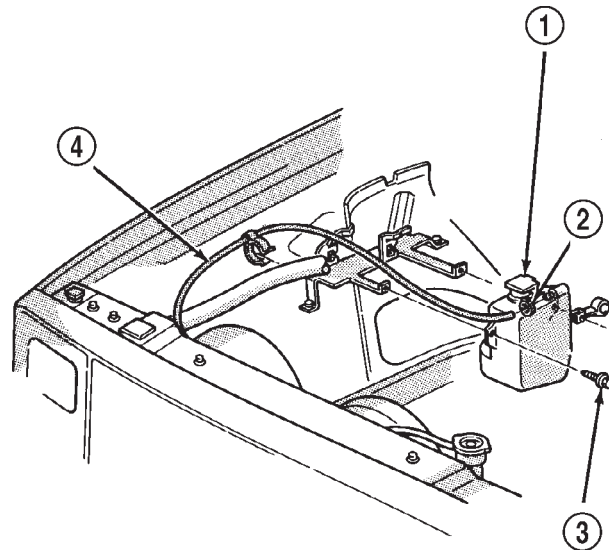

Fig. 23 Reserve/Overflow Tank—Except Right Hand Drive

J9407-26

- 1 - COOLANT RESERVE/OVERFLOW TANK
- 2 - CLAMP
- 3 - MOUNTING BOLTS
- 4 - TUBE TO RADIATOR



## REMOVAL AND INSTALLATION (Continued)

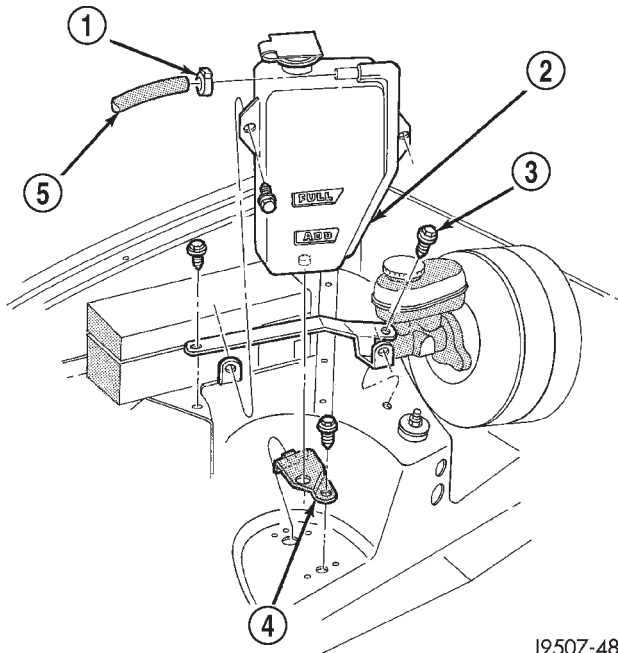

J9507-48

**Fig. 24 Reserve/Overflow Tank—With Right Hand Drive**

- 1 - CLAMP
- 2 - COOLANT RESERVE/OVERFLOW TANK
- 3 - MOUNTING BOLTS
- 4 - LOWER BRACKET
- 5 - TUBE TO RADIATOR

## INSTALLATION

(1) Position tank and tighten to 2 N·m (17 in. lbs.) torque.

(2) Position tube and secure clamp.

## WATER PUMP

**CAUTION:** If the water pump is replaced because of mechanical damage, the fan blades and viscous fan drive should also be inspected. These components could have been damaged due to excessive vibration.

The water pump can be removed without discharging the air conditioning system (if equipped).

**CAUTION:** All engines have a reverse (counter-clockwise) rotating water pump. The letter R is stamped into the back of the water pump impeller (Fig. 25) to identify. Engines from previous model years, depending upon application, may be equipped with a forward (clockwise) rotating water pump. Installation of the wrong water pump will cause engine over heating.

**FRONT VIEW**  
ROTATION DIRECTION  
AS VIEWED

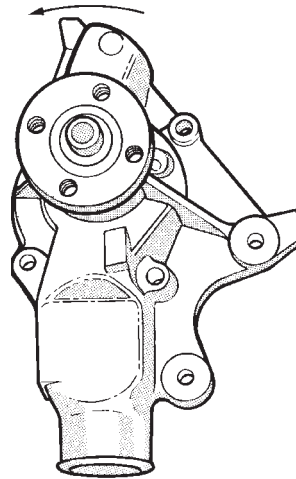

**BACK VIEW**  
ROTATION DIRECTION  
AS VIEWED

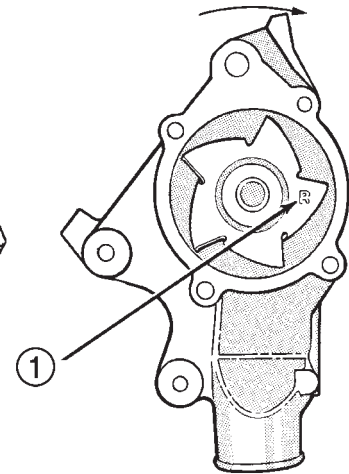

J9307-10

**Fig. 25 Reverse Rotating Water Pump—Typical**

1 - R STAMPED INTO IMPELLER

The water pump impeller is pressed on the rear of the pump shaft and bearing assembly. The water pump is serviced only as a complete assembly.

**WARNING: DO NOT REMOVE THE BLOCK DRAIN PLUG(S) OR LOOSEN RADIATOR DRAINCOCK WITH THE SYSTEM HOT AND UNDER PRESSURE. SERIOUS BURNS FROM COOLANT CAN OCCUR.**

DO NOT WASTE reusable coolant. If the solution is clean, drain coolant into a clean container for reuse.

## REMOVAL-2.5L ENGINE (LHD/RHD)

- (1) Disconnect battery negative cable.
- (2) Drain cooling system. Refer to Cooling System-Draining and Filling in this group.
- (3) Remove upper radiator hose.
- (4) Loosen (but do not remove at this time) the four fan hub-to-water pump pulley mounting nuts (Fig. 26).
- (5) Remove accessory drive belt. (Refer to Accessory Drive Belt, Removal and Installation in this group)
- (6) Disconnect electric cooling fan connector (if equipped).
- (7) Unbolt fan shroud.
- (8) Remove the four fan hub-to-water pump pulley nuts and remove fan and shroud together.

## REMOVAL AND INSTALLATION (Continued)

**CAUTION:** After removing fan blade/viscous fan drive assembly, do not place thermal viscous fan drive in horizontal position. If stored horizontally, silicone fluid in viscous fan drive could drain into its bearing assembly and contaminate lubricant.

(9) Remove power steering pump and bracket (Fig. 27), refer to Group 19 Steering for correct procedure.

(10) Remove lower radiator hose from water pump. Remove heater hose from water pump pipe.

(11) Remove the four pump mounting bolts (Fig. 28) and remove pump from vehicle. Discard old gasket. Note that one of the four bolts is longer than the other bolts.

(12) If pump is to be replaced, the heater hose fitting must be removed. Note position of fitting before removal.

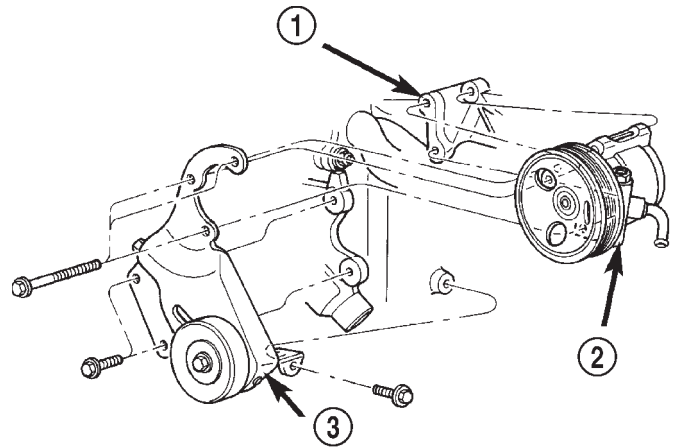

**Fig. 27 Power Steering Pump Attachment-2.5L**

- 80a871e2
- 1 - INTAKE MANIFOLD
  - 2 - PUMP ASSEMBLY 2.5L
  - 3 - PUMP BRACKET

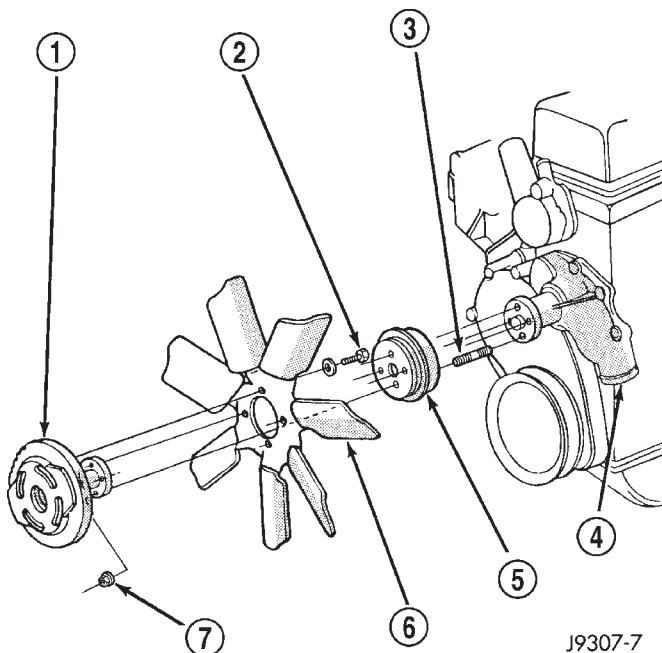

**Fig. 26 Fan Mounting Nuts**

- J9307-7
- 1 - THERMAL VISCOUS FAN DRIVE
  - 2 - (4) FAN BLADE-TO-VISCOUS DRIVE BOLTS
  - 3 - (4) FAN HUB-TO-PUMP PULLEY STUDS
  - 4 - WATER PUMP
  - 5 - WATER PUMP PULLEY
  - 6 - FAN BLADE
  - 7 - (4) FAN HUB-TO-PUMP PULLEY NUTS

## INSTALLATION-2.5L ENGINE (LHD/RHD)

(1) If pump is being replaced, install the heater hose pipe to the pump. Use a sealant on the fitting such as Mopar® Thread Sealant With Teflon. Refer to the directions on the package.

(2) Clean the gasket mating surfaces. If the original pump is used, remove any deposits or other foreign material. Inspect the cylinder block and water

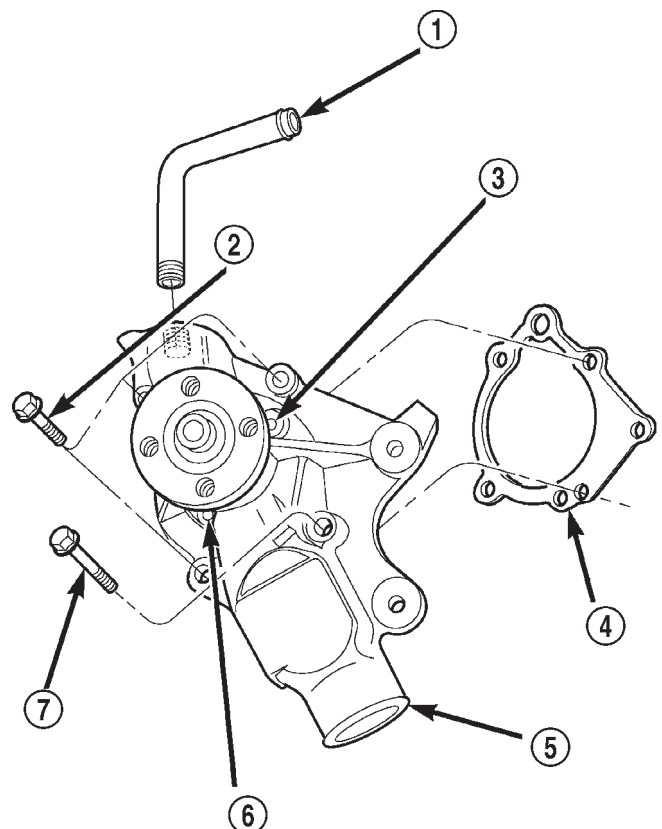

**Fig. 28 Water Pump Remove/Install—Typical**

- 80bcea54
- 1 - HEATER HOSE FITTING
  - 2 - UPPER VENT HOLE
  - 3 - PUMP GASKET
  - 4 - WATER PUMP
  - 5 - LOWER VENT HOLE
  - 6 - LONG BOLT
  - 7 - BOLTS (3) SHORT

## REMOVAL AND INSTALLATION (Continued)

pump mating surfaces for erosion or damage from cavitation.

(3) Install the gasket and water pump. The silicone bead on the gasket should be facing the water pump. Also, the gasket is installed dry. Tighten mounting bolts to 23 N·m (17 ft. lbs.) torque. Rotate the shaft by hand to be sure it turns freely.

(4) Connect the radiator and heater hoses to the water pump.

(5) Install power steering pump and bracket. Refer to Group 19, Steering.

(6) Position water pump pulley to water pump hub.

(7) Install shroud and fan together and install four nuts to water pump hub studs. Tighten nuts to 27 N·m (20 ft. lbs.) torque.

(8) Install and tighten upper fan shroud nuts to 4 N·m (31 in. lbs.).

(9) Connect electric fan connector (if equipped).

**CAUTION:** When installing the accessory drive belt, the belt **MUST** be routed correctly. If not, the engine may overheat due to the water pump rotating in the wrong direction. Refer to the Belt Removal and Installation in this group for appropriate belt routing. You may also refer to the Belt Routing Label in the vehicle engine compartment.

(10) Install and tension accessory drive belt, refer to Accessory Drive Belt removal and installation in this group.

(11) Install upper radiator hose.

(12) Fill cooling system with coolant and check for leaks. Refer to Refilling Cooling System in this group.

(13) Connect battery negative cable.

(14) Start and warm the engine. Check for leaks.

## REMOVAL-4.0L ENGINE (LHD/RHD)

(1) Disconnect battery negative cable.

(2) Drain the cooling system. (Refer to Cooling System-Draining and Filling in this group.)

(3) Disconnect electric cooling fan connector.

(4) Remove electric cooling fan/shroud assembly (if equipped).

(5) Remove viscous fan shroud bolts (2).

(6) Loosen (but do not remove at this time) the four water pump pulley-to-water pump hub mounting bolts (Fig. 29) and the four viscous fan to idler pulley nuts.

**NOTE:** The accessory drive belt must be removed prior to removing the fan (if installed at pump) or fan pulley.

(7) Remove accessory drive belt (refer to Accessory Drive Belt, Removal and Installation in this group)

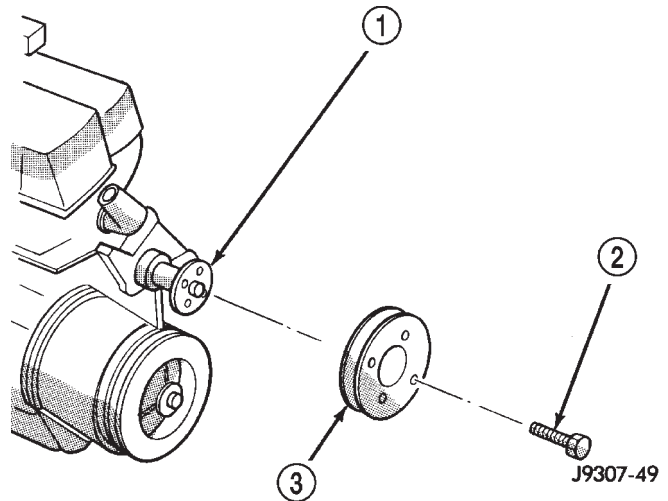

**Fig. 29 Water Pump Pulley Bolts**

1 - WATER PUMP HUB

2 - BOLTS (4)

3 - PUMP PULLEY

(8) Remove the four viscous fan to idler pulley nuts and remove the fan and shroud together.

**CAUTION:** After removing fan blade/viscous fan drive assembly, do not place thermal viscous fan drive in horizontal position. If stored horizontally, silicone fluid in viscous fan drive could drain into its bearing assembly and contaminate lubricant.

(9) Remove the four water pump pulley bolts and remove the pulley.

(10) Remove power steering pump and bracket (Fig. 30), refer to Group 19 Steering.

(11) Remove lower radiator hose from water pump. Remove heater hose from water pump fitting.

(12) Remove the four pump mounting bolts (Fig. 31) and remove pump from vehicle. Discard old gasket. Note that one of the four bolts is longer than the other bolts.

(13) If pump is to be replaced, the heater hose fitting must be removed. Note position of fitting before removal.

## INSTALLATION-4.0L ENGINE (LHD/RHD)

(1) If pump is being replaced, install the heater hose fitting to the pump. Use a sealant on the fitting such as Mopar® Thread Sealant With Teflon. Refer to the directions on the package.

(2) Clean the gasket mating surfaces. If the original pump is used, remove any deposits or other foreign material. Inspect the cylinder block and water pump mating surfaces for erosion or damage from cavitation.

(3) Install the gasket and water pump. The silicone bead on the gasket should be facing the water

REMOVAL AND INSTALLATION (Continued)

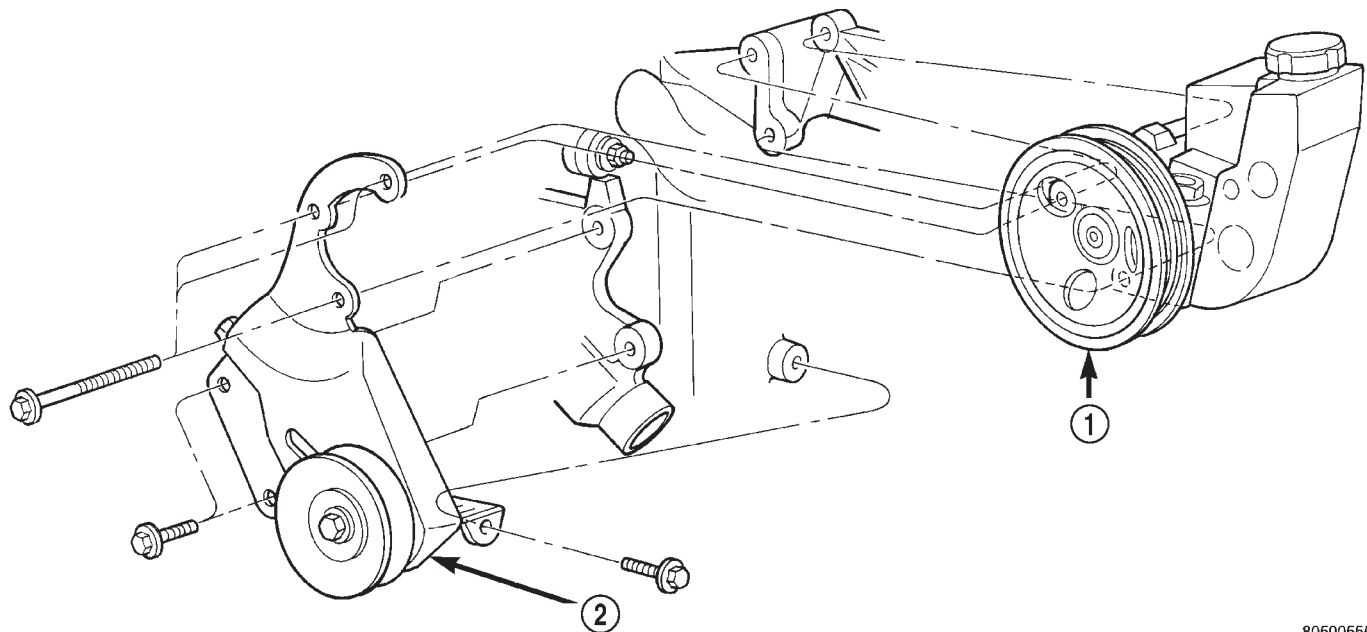

**Fig. 30 Power Steering Pump Attachment-4.0L**

80500555

- 1 - PUMP ASSEMBLY
- 2 - PUMP BRACKET

pump. Also, the gasket is installed dry. Tighten mounting bolts to 23 N·m (17 ft. lbs.) torque. Rotate the shaft by hand to be sure it turns freely.

(4) Connect the radiator and heater hoses to the water pump.

(5) Position water pump pulley to water pump hub.

(6) Install four pump pulley bolts. Tighten bolts (or nuts) to 27 N·m (20 ft. lbs.) torque.

(7) Install power steering pump. Refer to Group 19, Steering for proper procedure and torque values.

(8) Install the viscous fan and shroud together. Install the four fan to idler pulley nuts and tighten to 27 N·m (20 ft. lbs.).

**CAUTION:** When installing the accessory drive belt, the belt **MUST** be routed correctly. If not, the engine may overheat due to the water pump rotating in the wrong direction. Refer to the Belt Removal and Installation in this group for appropriate belt routing. You may also refer to the Belt Routing Label in the vehicle engine compartment.

(9) Install and tighten viscous fan shroud bolts to 4 N·m (31 in. lbs.).

(10) Install and tension the accessory drive belt, refer to Accessory Drive Belt removal and installation in this group.

(11) Install the electric cooling fan/shroud assy.

(12) Install and tighten electric fan shroud bolts to 4 N·m (31 in. lbs.). Connect fan connector.

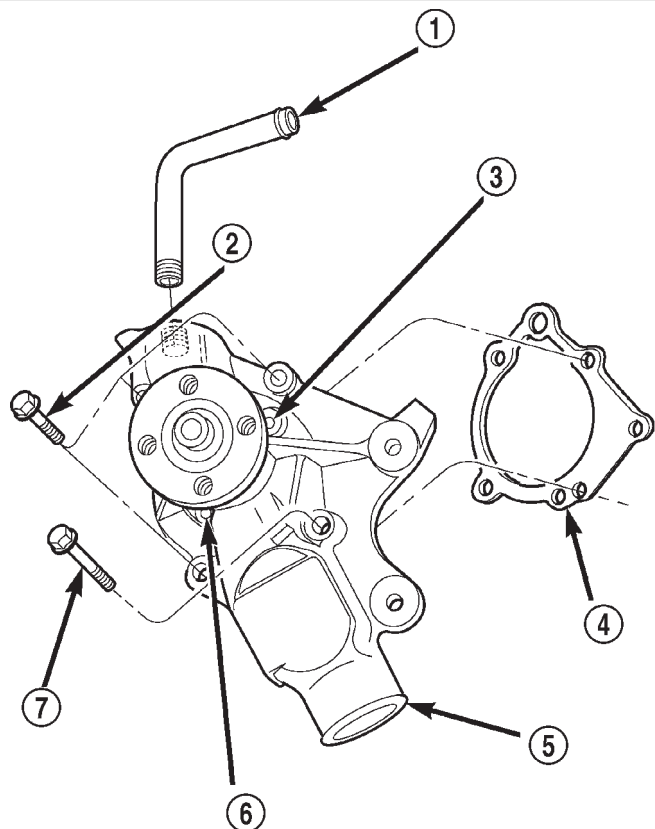

**Fig. 31 Water Pump Remove/Install—Typical**

80bcea54

- 1 - HEATER HOSE FITTING
- 2 - UPPER VENT HOLE
- 3 - PUMP GASKET
- 4 - WATER PUMP
- 5 - LOWER VENT HOLE
- 6 - LONG BOLT
- 7 - BOLTS (3) SHORT



## REMOVAL AND INSTALLATION (Continued)

(13) Fill cooling system with coolant and check for leaks. Refer to Refilling Cooling System in this group.

(14) Connect battery negative cable.

(15) Start and warm the engine. Check for leaks.

## THERMOSTAT

## REMOVAL

**WARNING: DO NOT LOOSEN THE RADIATOR DRAINCOCK WITH THE SYSTEM HOT AND PRESSURIZED. SERIOUS BURNS FROM THE COOLANT CAN OCCUR.**

DO NOT WASTE reusable coolant. If the solution is clean, drain the coolant into a clean container for reuse.

(1) Drain the coolant from the radiator until the level is below the thermostat housing.

**WARNING: CONSTANT TENSION HOSE CLAMPS ARE USED ON MOST COOLING SYSTEM HOSES. WHEN REMOVING OR INSTALLING, USE ONLY TOOLS DESIGNED FOR SERVICING THIS TYPE OF CLAMP, SUCH AS SPECIAL CLAMP TOOL (NUMBER 6094) (Fig. 12). SNAP-ON CLAMP TOOL (NUMBER HPC-20) MAY BE USED FOR LARGER CLAMPS. ALWAYS WEAR SAFETY GLASSES WHEN SERVICING CONSTANT TENSION CLAMPS.**

**CAUTION: A number or letter is stamped into the tongue of constant tension clamps (Fig. 11). If replacement is necessary, use only an original equipment clamp with matching number or letter.**

(2) Remove radiator upper hose and heater hose at thermostat housing.

(3) Disconnect wiring connector at engine coolant temperature sensor.

(4) Remove thermostat housing mounting bolts, thermostat housing, gasket and thermostat (Fig. 32). Discard old gasket.

(5) Clean the gasket mating surfaces.

## INSTALLATION

(1) Install the replacement thermostat so that the pellet, which is encircled by a coil spring, faces the engine. All thermostats are marked on the outer flange to indicate the proper installed position.

(a) Observe the recess groove in the engine cylinder head (Fig. 33).

(b) Position thermostat into this groove with arrow and air bleed hole on outer flange pointing up.

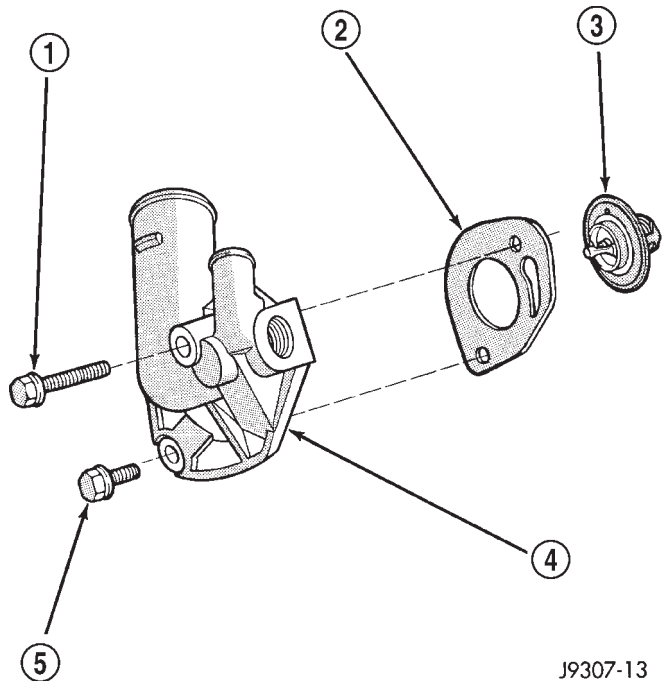

J9307-13

**Fig. 32 Thermostat Removal/Installation**

- 1 - LONG BOLT
- 2 - GASKET
- 3 - THERMOSTAT
- 4 - THERMOSTAT HOUSING
- 5 - SHORT BOLT

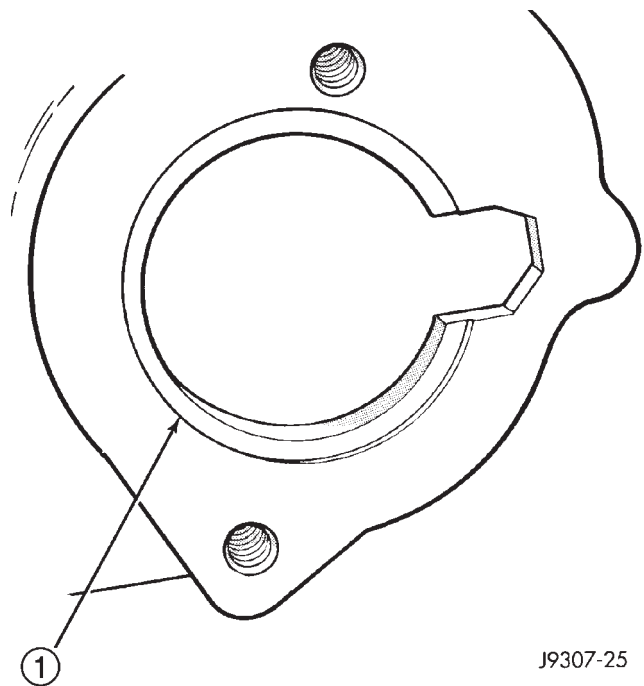

J9307-25

**Fig. 33 Thermostat Recess**

- 1 - GROOVE

(2) Install replacement gasket and thermostat housing.



## REMOVAL AND INSTALLATION (Continued)

**CAUTION:** Tightening the thermostat housing unevenly or with the thermostat out of its recess may result in a cracked housing.

- (3) Tighten the housing bolts to 20 N·m (15 ft. lbs.) torque.
- (4) Install hoses to thermostat housing.
- (5) Install electrical connector to coolant temperature sensor.
- (6) Be sure that the radiator draincock is tightly closed. Fill the cooling system to the correct level with the required coolant mixture. Refer to Refilling Cooling System in this group.
- (7) Start and warm the engine. Check for leaks.

## RADIATOR—2.5L

**WARNING:** DO NOT REMOVE THE CYLINDER BLOCK DRAIN PLUGS OR LOOSEN THE RADIATOR DRAINCOCK WITH THE SYSTEM HOT AND PRESSURIZED. SERIOUS BURNS FROM THE COOLANT CAN OCCUR.

DO NOT WASTE reusable coolant. If solution is clean, drain coolant into a clean container for reuse.

**WARNING:** CONSTANT TENSION HOSE CLAMPS ARE USED ON MOST COOLING SYSTEM HOSES. WHEN REMOVING OR INSTALLING, USE ONLY TOOLS DESIGNED FOR SERVICING THIS TYPE OF CLAMP, SUCH AS SPECIAL CLAMP TOOL (NUMBER 6094) (Fig. 12). SNAP-ON CLAMP TOOL (NUMBER HPC-20) MAY BE USED FOR LARGER CLAMPS. ALWAYS WEAR SAFETY GLASSES WHEN SERVICING CONSTANT TENSION CLAMPS.

**CAUTION:** A number or letter is stamped into the tongue of constant tension clamps (Fig. 11). If replacement is necessary, use only an original equipment clamp with matching number or letter.

## REMOVAL

- (1) Disconnect battery negative cable.
- (2) Observe the previous **WARNINGS**.
- (3) Remove radiator pressure cap.
- (4) For access to radiator draincock, remove radiator grill mounting screws and remove grill. Refer to Group 23, Body for procedures.
- (5) Attach one end of a 24 inch long X 1/4 inch ID hose to the radiator petcock (Fig. 34). Put the other end into a clean container. Open petcock and drain radiator.
- (6) Detach power steering fluid reservoir from fan shroud and lay aside.

- (7) Disconnect electric cooling fan electrical connector, if equipped.

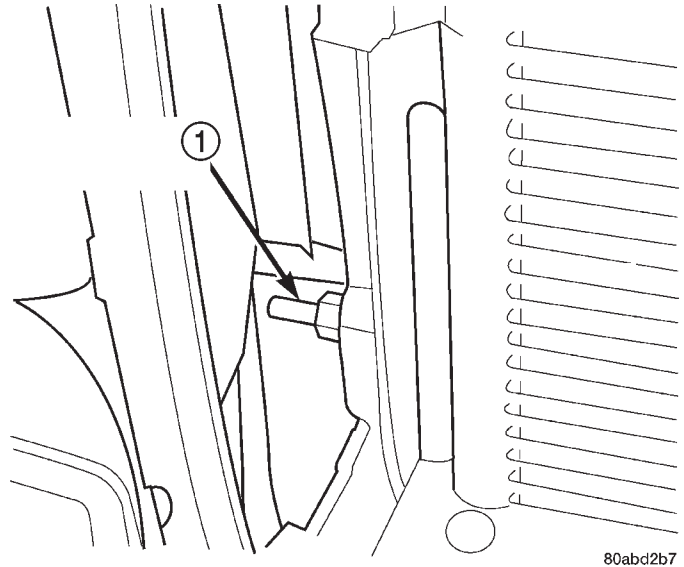

80abd2b7

**Fig. 34 Radiator Petcock—Typical**

1 - RADIATOR PETCOCK

- (8) Disconnect CRS hose from radiator filler neck and remove from shroud retaining loops.
- (9) Remove the four (4) viscous fan/drive assembly nuts from the water pump pulley and remove fan/drive assy.
- (10) Remove the four (4) fan shroud to core support mounting screws.
- (11) Remove the electric fan (if equipped) and shroud assembly from the vehicle (Fig. 36).
- (12) Remove radiator upper crossmember (Fig. 36).
- (13) If equipped with air conditioning, separate radiator from condenser by removing condenser-to-radiator mounting brackets (Fig. 35).
- (14) Disconnect upper and lower radiator hoses.
- (15) If equipped, disconnect and plug automatic transmission fluid cooler lines. Quick Connect Fitting Release Tool 6935 may be needed. If equipped with remote transmission cooler, remove line to cooler from bracket at bottom of radiator.
- (16) Lift radiator straight up and out of engine compartment taking care not to damage fins.
- (17) If radiator is to be replaced, be sure to remove and transfer any components not included with replacement radiator.

## INSTALLATION

The radiator is supplied with two alignment dowels (Fig. 41). They are located on the bottom tank and fit into rubber grommets in the radiator lower crossmember.

## REMOVAL AND INSTALLATION (Continued)

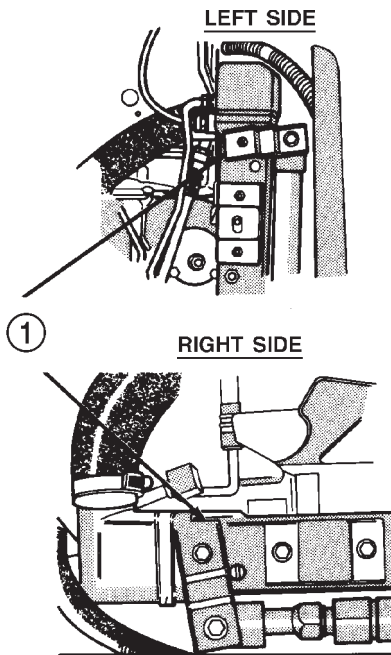

J-8907-26

**Fig. 35 Condenser-to-Radiator Mounting Brackets**

1 - CONDENSER TO RADIATOR MOUNTING BRACKETS

(1) Lower radiator into engine compartment. Position alignment dowels into rubber grommets in radiator lower crossmember (Fig. 41).

(2) If equipped with air conditioning, attach condenser to radiator with mounting brackets (Fig. 35).

(3) Install radiator upper crossmember and four mounting bolts.

(4) Install radiator upper crossmember-to-isolator nuts. Tighten nuts to 10 N·m (86 in. lbs.) torque. If isolator-to-radiator nuts had been removed, tighten them to 5 N·m (47 in. lbs.) torque.

(5) Connect radiator upper and lower hoses.

(6) If equipped, connect automatic transmission fluid cooler lines. If equipped with remote cooler, attach cooler line to bracket at bottom of radiator.

(7) Install electric fan (if equipped) and shroud assembly. Insert alignment tabs at bottom of fan shroud into slots in bracket at bottom of radiator. Tighten mounting bolts to 3 N·m (31 in. lbs.) torque.

(8) Connect electric cooling fan electrical connector.

(9) Install power steering reservoir to fan shroud.

(10) Install grill.

(11) Connect battery negative cable.

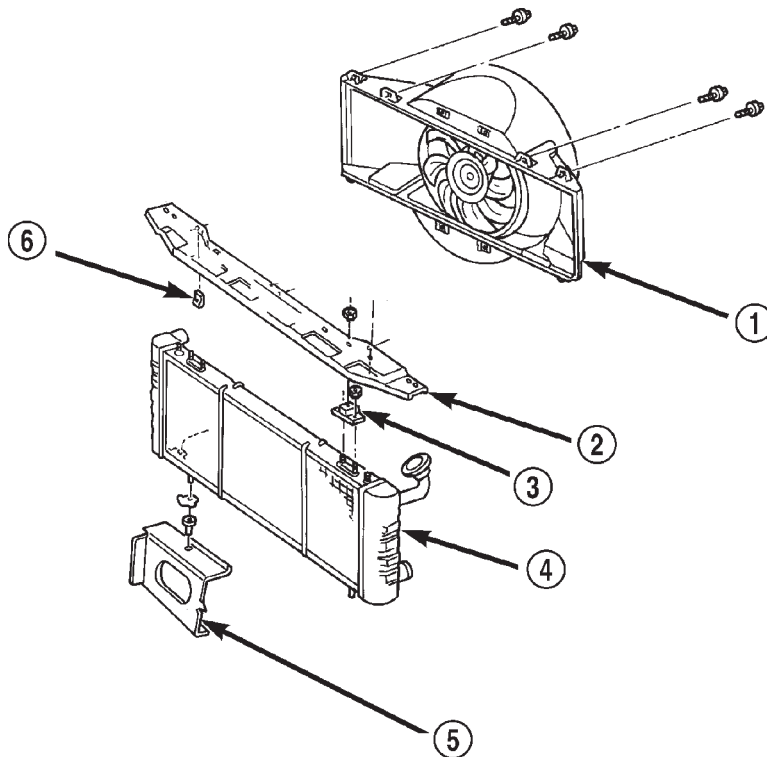
**Fig. 36 Radiator Removal/Installation—2.5L Engines**

80ae8363

1 - ELECTRIC FAN/SHROUD ASSEMBLY

2 - UPPER CROSSMEMBER

3 - ISOLATOR

4 - RADIATOR

5 - LOWER CROSSMEMBER

6 - U-NUT

REMOVAL AND INSTALLATION (Continued)

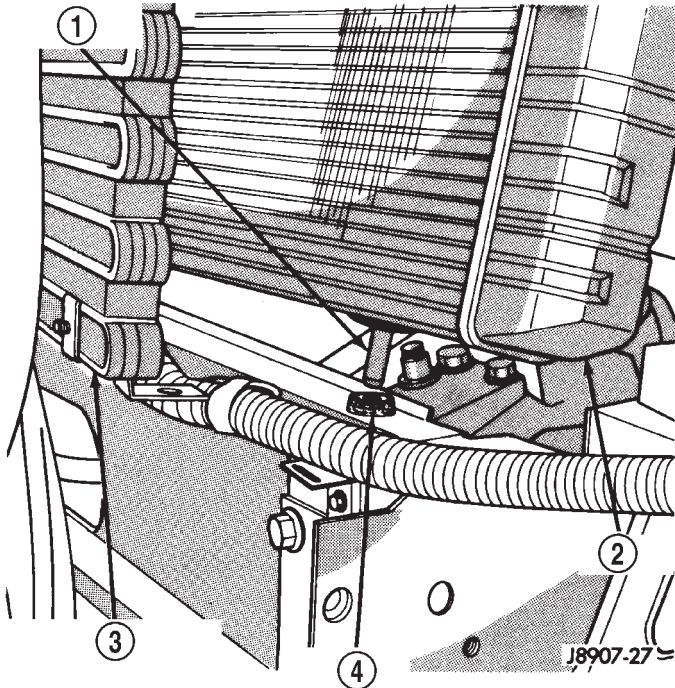

**Fig. 37 Radiator Alignment Dowels—Typical**

- 1 - ALIGNMENT DOWEL
- 2 - RADIATOR
- 3 - AIR CONDITIONING CONDENSER
- 4 - GROMMET

- (12) Fill cooling system with correct coolant. Refer to the Coolant section of this group.
- (13) Install pressure cap.
- (14) Check and adjust automatic transmission fluid level (if equipped).
- (15) Start engine and visually check for leaks.

**RADIATOR—4.0L**

**WARNING: DO NOT REMOVE THE CYLINDER BLOCK DRAIN PLUGS OR LOOSEN THE RADIATOR DRAINCOCK WITH THE SYSTEM HOT AND PRESSURIZED. SERIOUS BURNS FROM THE COOLANT CAN OCCUR.**

DO NOT WASTE reusable coolant. If solution is clean, drain coolant into a clean container for reuse.

**WARNING: CONSTANT TENSION HOSE CLAMPS ARE USED ON MOST COOLING SYSTEM HOSES. WHEN REMOVING OR INSTALLING, USE ONLY TOOLS DESIGNED FOR SERVICING THIS TYPE OF CLAMP, SUCH AS SPECIAL CLAMP TOOL (NUMBER 6094) (Fig. 12). SNAP-ON CLAMP TOOL (NUMBER HPC-20) MAY BE USED FOR LARGER CLAMPS. ALWAYS WEAR SAFETY GLASSES WHEN SERVICING CONSTANT TENSION CLAMPS.**

**CAUTION: A number or letter is stamped into the tongue of constant tension clamps (Fig. 11). If replacement is necessary, use only an original equipment clamp with matching number or letter.**

**REMOVAL**

- (1) Disconnect battery negative cable.
- (2) Observe the previous **WARNINGS**.
- (3) Remove radiator pressure cap.
- (4) For access to radiator draincock, remove radiator grill mounting screws and remove grill. Refer to Group 23, Body for procedures.
- (5) Attach one end of a 24 inch long X 1/4 inch ID hose to the radiator petcock (Fig. 38). Put the other end into a clean container. Open petcock and drain radiator.
- (6) Disconnect electric cooling fan electrical connector, if equipped.

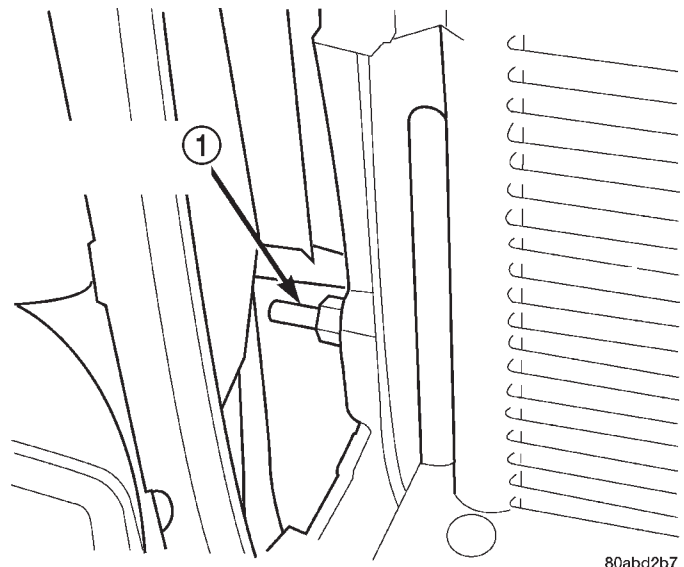

**Fig. 38 Radiator Petcock—Typical**

- 1 - RADIATOR PETCOCK

(7) If equipped, remove two electric cooling fan mounting bolts. Lift cooling fan straight up until alignment tabs at the bottom are clear of slots in bracket at bottom of radiator (Fig. 39).

(8) Remove the two mechanical (non-electrical) fan shroud mounting bolts. Lift shroud straight up until alignment tabs at the bottom are clear of slots in bracket at bottom of radiator (Fig. 39). Place shroud over mechanical fan.

(9) If equipped, disconnect and plug automatic transmission fluid cooler lines. Quick Connect Fitting Release Tool 6935 may be needed. If equipped with remote transmission cooler, remove line to cooler from bracket at bottom of radiator.

## REMOVAL AND INSTALLATION (Continued)

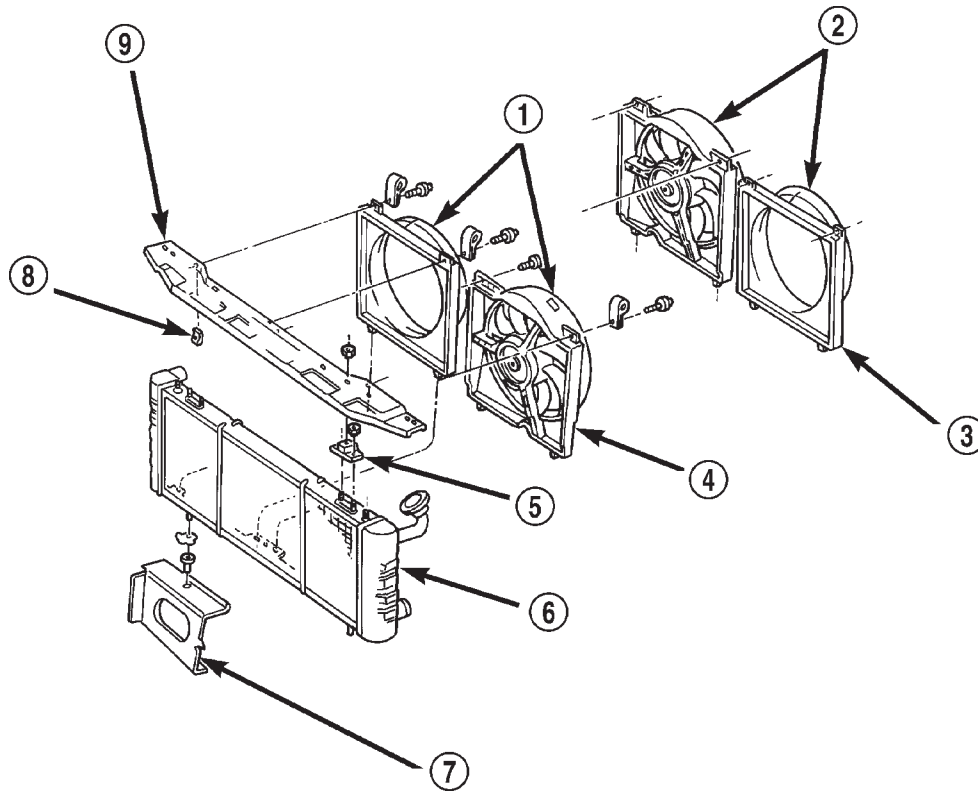

80ae8364

**Fig. 39 Radiator Removal/Installation—4.0L Engines**

- |                         |                       |
|-------------------------|-----------------------|
| 1 - (LHD)               | 6 - RADIATOR          |
| 2 - (RHD)               | 7 - LOWER CROSSMEMBER |
| 3 - VISCOUS FAN SHROUD  | 8 - U-NUT             |
| 4 - ELECTRIC FAN MODULE | 9 - UPPER CROSSMEMBER |
| 5 - ISOLATOR            |                       |

(10) Disconnect radiator upper and lower hoses clamps. Disconnect radiator upper and lower hoses.

(11) Mark the position of the hood latch striker on the radiator crossmember and remove hood latch striker.

(12) Remove two radiator upper crossmember to isolator nuts (Fig. 39).

(13) Remove four radiator upper crossmember bolts and remove upper crossmember.

(14) If equipped with air conditioning, separate radiator from condenser by removing condenser-to-radiator mounting brackets (Fig. 40).

(15) Lift radiator straight up and out of engine compartment taking care not to damage fins.

**INSTALLATION**

The radiator is supplied with two alignment dowels (Fig. 41). They are located on the bottom tank and fit into rubber grommets in the radiator lower crossmember.

(1) Lower radiator into engine compartment. Position alignment dowels into rubber grommets in radiator lower crossmember (Fig. 41)

(2) If equipped with air conditioning, attach condenser to radiator with mounting brackets (Fig. 40).

(3) Install radiator upper crossmember and four mounting bolts.

(4) Install radiator upper crossmember-to-isolator nuts. Tighten nuts to 10 N·m (86 in. lbs.) torque. If isolator-to-radiator nuts had been removed, tighten them to 5 N·m (47 in. lbs.) torque.

(5) Install hood latch striker. Note previously marked position.

(6) Connect radiator upper and lower hoses.

(7) If equipped, connect automatic transmission fluid cooler lines. Refer to Group 21, Transmissions for procedures. If equipped with remote cooler, attach cooler line to bracket at bottom of radiator.



REMOVAL AND INSTALLATION (Continued)

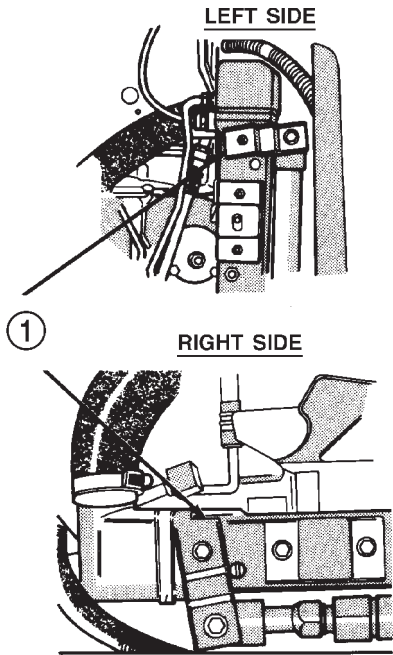

J-8907-26

**Fig. 40 Condenser to Radiator Mounting Brackets—4.0L Engine**

1 - CONDENSER TO RADIATOR MOUNTING BRACKETS

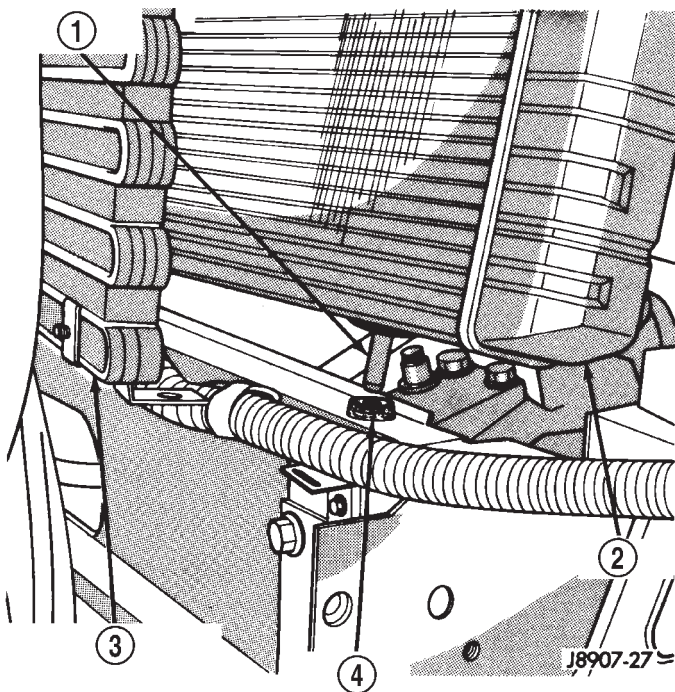

J-8907-27

**Fig. 41 Radiator Alignment Dowels—Typical**

1 - ALIGNMENT DOWEL  
 2 - RADIATOR  
 3 - AIR CONDITIONING CONDENSER  
 4 - GROMMET

(8) Install electric cooling fan (if equipped). Insert alignment tabs at bottom of fan shroud into slots in bracket at bottom of radiator. Tighten mounting bolts to 3 N-m (31 in. lbs.) torque.

(9) Connect electric cooling fan electrical connector.

(10) Install mechanical cooling fan shroud. Insert alignment tabs at bottom of shroud into slots in bracket at bottom of radiator. Tighten mounting bolts to 3 N-m (31 in. lbs.) torque.

(11) Close radiator draincock.

(12) Install grill.

(13) Connect negative battery cable.

(14) Fill cooling system with correct coolant. Refer to the Coolant section of this group.

(15) Install pressure cap.

(16) Check and adjust automatic transmission fluid level (if equipped).

**ELECTRIC COOLING FAN—2.5L**

The electric fan module is only to be serviced as an assembly.

**REMOVAL**

(1) Disconnect battery negative cable.

(2) Disconnect CRS hose from radiator filler neck and pull through (remove) the shroud retaining loops.

(3) Detach power steering reservoir from fan shroud and lay aside.

(4) Remove the four viscous fan/drive assembly mounting nuts from the water pump studs and remove viscous fan assembly.

(5) Disconnect cooling fan electrical connector.

(6) Remove the four upper fan shroud to radiator crossmember mounting screws (Fig. 42).

(7) Lift fan and shroud assy. from vehicle

(8) Detach fan harness from shroud.

(9) Remove four fan module to shroud phillips head screws (Fig. 43) and remove module from shroud.

**INSTALLATION**

(1) Position fan module in shroud so that the harness exits the motor at the 12 o'clock position (Fig. 43).

(2) Install and tighten fan module to shroud screws to 3 N-m (31 in. lbs.).

(3) Route fan harness through the shroud and attach to shroud at correct position.

(4) Lower fan and shroud assembly into place, making sure the shroud alignment tabs rest in their corresponding lower radiator slots.

(5) Install upper fan shroud screws and tighten to 3 N-m (31 in. lbs.).



## REMOVAL AND INSTALLATION (Continued)

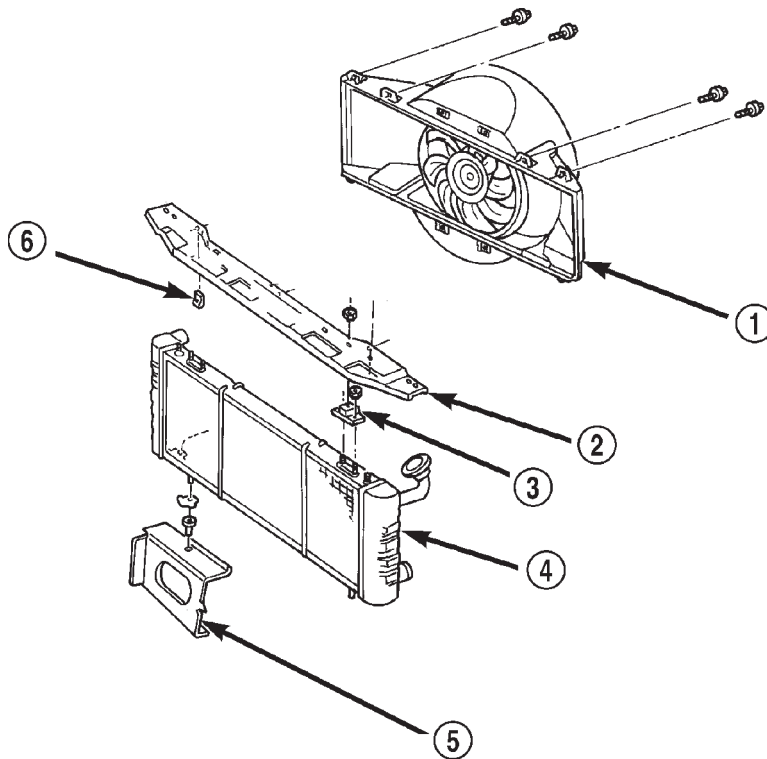

80ae8363

**Fig. 42 Fan Shroud Removal/Installation**

- 1 - ELECTRIC FAN/SHROUD ASSEMBLY  
 2 - UPPER CROSSMEMBER  
 3 - ISOLATOR

- 4 - RADIATOR  
 5 - LOWER CROSSMEMBER  
 6 - U-NUT

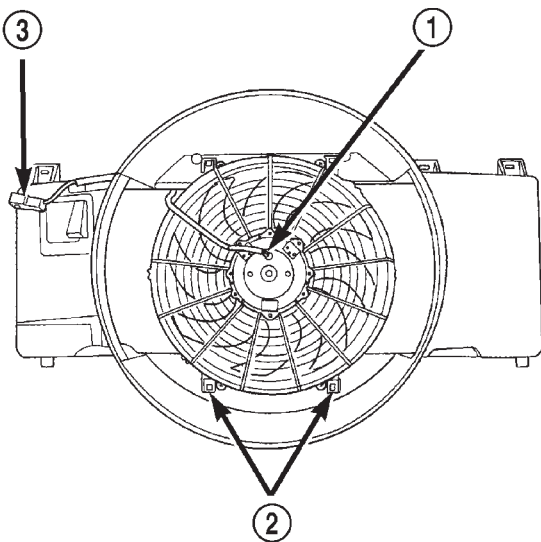

80b04ff0

**Fig. 43 Fan Module Orientation and Mounting**

- 1 - FAN MOTOR HARNESS AT 12 O'CLOCK POSITION  
 2 - MOUNTING SCREWS (4)  
 3 - FAN CONNECTOR

- (6) Connect fan electrical connector.  
 (7) Install power steering reservoir to shroud.  
 (8) Install viscous fan drive assy. to water pump hub and tighten nuts to 27 N·m (20 ft. lbs.)  
 (9) Connect battery negative cable.

**ELECTRIC COOLING FAN—4.0L****REMOVAL**

The auxiliary cooling fan is attached to the radiator upper crossmember behind the radiator.

- (1) Remove the two fan mounting bolts from radiator upper crossmember (Fig. 44).  
 (2) Disconnect the electric fan connector.  
 (3) Lift fan straight up and out of vehicle.

**INSTALLATION**

- (1) Align lower retaining tabs of fan shroud with slots in bracket at bottom of radiator. Push fan down into position.  
 (2) Tighten the mounting bolts to 4 N·m (31 in. lbs.) torque.

REMOVAL AND INSTALLATION (Continued)

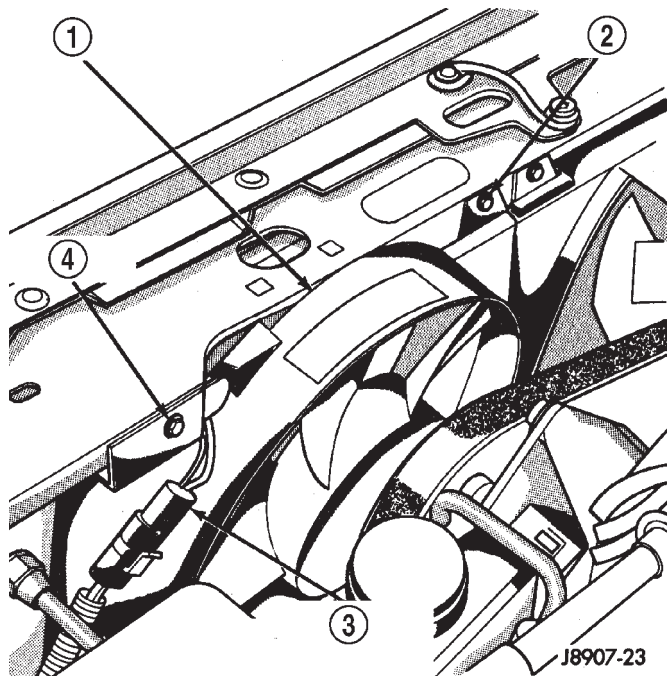

**Fig. 44 Auxiliary Cooling Fan—Remove/Install—Typical**

- 1 - ELECTRIC COOLING FAN
- 2 - MOUNTING BOLT
- 3 - ELECTRIC COOLING FAN CONNECTOR
- 4 - MOUNTING BOLT

(3) Connect auxiliary cooling fan electrical connector.

**BLOCK HEATER**

**REMOVAL**

Refer to correct illustration (Fig. 45) (Fig. 46) when servicing block heater.

**WARNING: DO NOT REMOVE THE CYLINDER BLOCK DRAIN PLUGS OR LOOSEN THE RADIATOR DRAINCOCK WITH THE SYSTEM HOT AND PRESSURIZED. SERIOUS BURNS FROM THE COOLANT CAN OCCUR.**

DO NOT WASTE reusable coolant. If solution is clean, drain coolant into a clean container for reuse.

- (1) Drain coolant from radiator and engine cylinder block.
- (2) Unplug power cord from block heater.
- (3) Loosen screw in center of block heater (Fig. 45) (Fig. 46).
- (4) Remove block heater from cylinder block.

**INSTALLATION**

- (1) Thoroughly clean the engine core hole and the block heater seat.

(2) Insert block heater assembly into core hole with element loop pointing **Up**.

(3) Seat block heater flush against block face. Tighten mounting screw to 3.6 N-m (32 in. lbs.) torque.

(4) Fill cooling system with coolant. Pressurize system and inspect for leaks.

(5) Plug power cord into block heater. Route cord away from moving parts, linkages and exhaust system components. Secure cord in place with tie-straps.

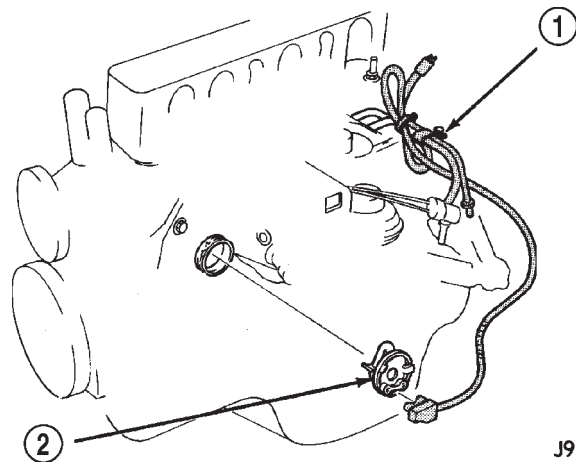

**Fig. 45 Heater and Cord—2.5L 4-Cylinder Engine**

- 1 - POWER CORD LOCATION
- 2 - BLOCK HEATER

**ENGINE ACCESSORY DRIVE BELTS**

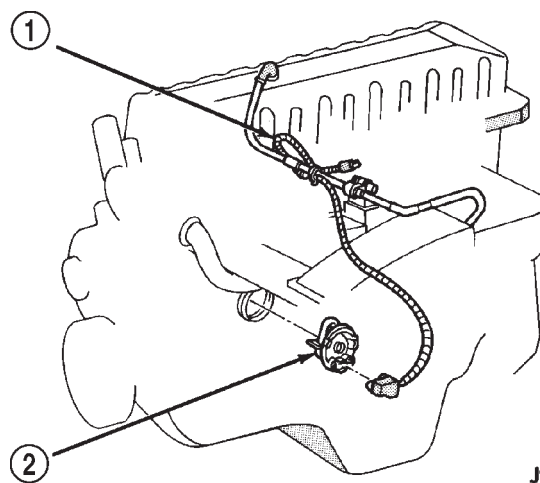

**Fig. 46 Heater and Cord—4.0L 6-Cylinder Engine**

- 1 - POWER CORD LOCATION
- 2 - BLOCK HEATER

Correct drive belt tension is required to ensure optimum performance of the belt driven engine accessories. There are different types of adjustment gauges for checking either a serpentine or a V-type belt. Refer to the instructions supplied with the

## REMOVAL AND INSTALLATION (Continued)

gauge. Use the correct gauge when checking belt tension. Place gauge in the middle of the section of belt being tested (between two pulleys) to check tension. Do not allow the gauge (or gauge adapter) to contact anything but the belt.

## BELT SCHEMATICS

The belt routing schematics are published from the latest information available at the time of publication. **If anything differs between these schematics and the Belt Routing Label, use the schematics on Belt Routing Label.** This label is located in the engine compartment.

Refer to (Fig. 47) (Fig. 48) (Fig. 49) (Fig. 50) for proper belt routing on vehicles with conventional left hand drive. Refer to (Fig. 51) (Fig. 52) for proper belt routing on vehicles with right hand drive (RHD). Or, refer to the Belt Routing Label located in the vehicle engine compartment.

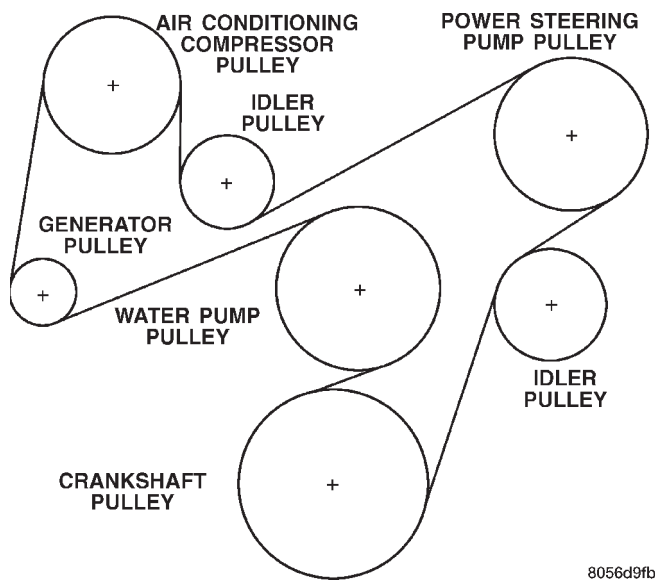

Fig. 47 Models with 2.5L Engine—With A/C

## BELT REPLACEMENT OR ADJUSTMENT—LEFT HAND DRIVE

Belt tension is adjusted at the power steering pump bracket and idler pulley assembly.

- (1) Disconnect negative battery cable from battery.
- (2) Loosen idler pulley bolt at the power steering pump bracket (Fig. 53).
- (3) Loosen adjusting bolt until belt can be removed from pulleys.
- (4) Remove belt.

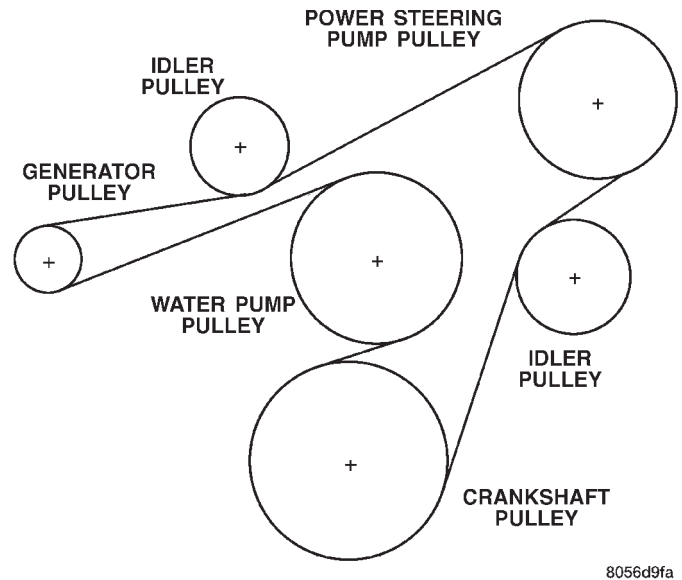

Fig. 48 Models with 2.5L Engine—Without A/C

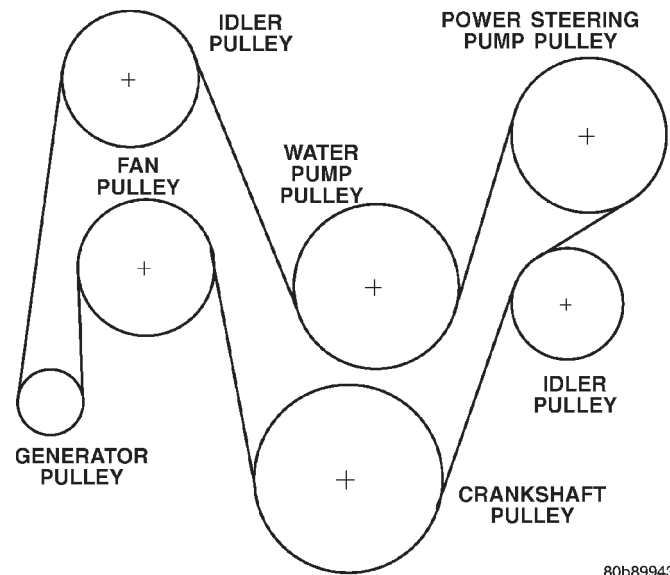

Fig. 49 Models with 4.0L Engine—Without A/C—Except RHD

## INSTALLATION

- (1) Check condition of all pulleys.

**CAUTION:** When installing the serpentine accessory drive belt, the belt **MUST** be routed correctly. If not, the engine may overheat due to the water pump rotating in the wrong direction. Refer to (Fig. 47) (Fig. 48) (Fig. 49) (Fig. 50) for correct belt routing.

REMOVAL AND INSTALLATION (Continued)

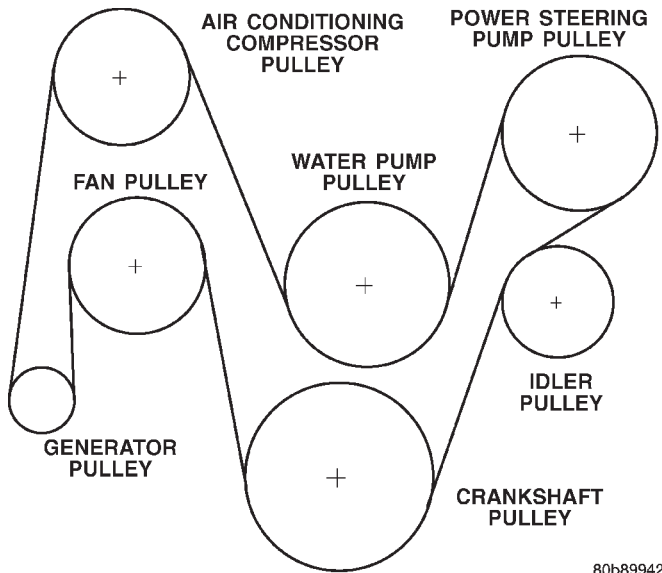

80b89942

**Fig. 50 Models With 4.0L Engine—With A/C—Except RHD**

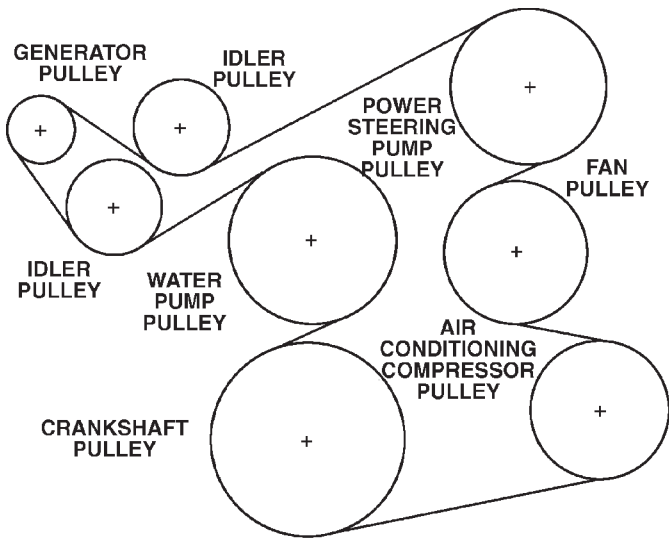

80570e04

**Fig. 51 Models With 4.0L Engine—With A/C—With RHD**

- (2) Install new belt.
- (3) Using serpentine belt tension gauge, tighten adjusting bolt until belt reaches proper tension. Refer to Belt Tension at the rear of this section for proper belt tension.
- (4) After belt is tensioned correctly, tighten idler pulley bolt to 47 N·m (35 ft. lbs.)
- (5) After idler pulley has been tightened into position, recheck belt tension. Adjust if necessary.

**BELT REPLACEMENT OR ADJUSTMENT—RIGHT HAND DRIVE (4.0L)**

- (1) Disconnect negative battery cable from battery.
- (2) Loosen lower alternator mounting bolt and nut.

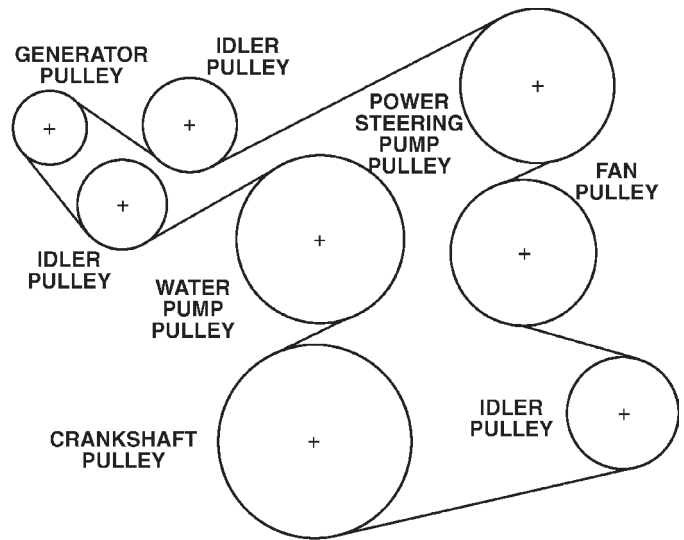

80570e03

**Fig. 52 Models With 4.0L Engine—Without A/C—With RHD**

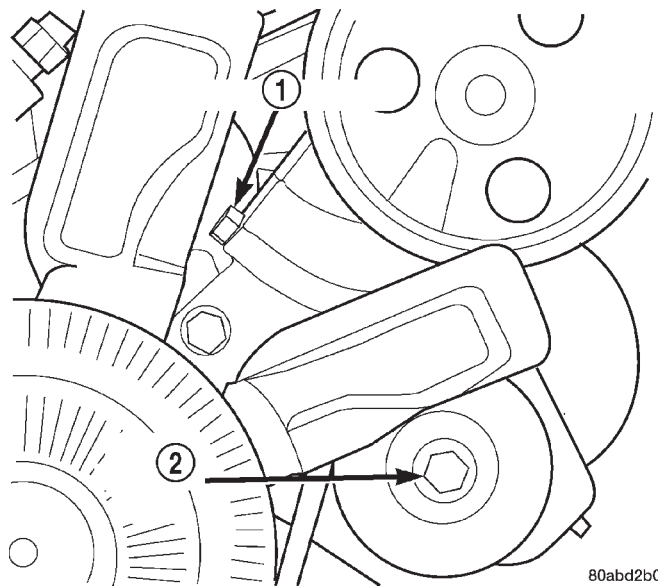

80abd2b0

**Fig. 53 Power Steering Pump Bracket and Idler Pulley**

- 1 - ADJUSTING BOLT
- 2 - IDLER PULLEY BOLT

- (3) Loosen upper alternator mounting nut.
- (4) Loosen adjusting bolt at upper alternator bracket (Fig. 54) until belt can be removed from pulleys.
- (5) Remove belt.

**INSTALLATION**

- (1) Check condition of all pulleys.

## REMOVAL AND INSTALLATION (Continued)

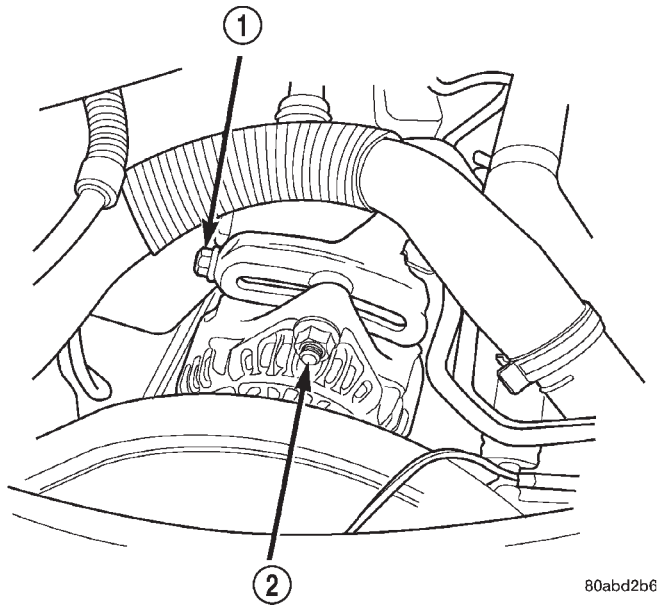

**Fig. 54 Generator Belt Tension Adjust Bracket**

- 1 - TENSION ADJUSTMENT BOLT  
2 - UPPER ALTERNATOR NUT

**CAUTION:** When installing the serpentine accessory drive belt, the belt **MUST** be routed correctly. If not, the engine may overheat due to the water pump rotating in the wrong direction. Refer to (Fig. 51) (Fig. 52) for correct belt routing.

- (2) Install new belt.
- (3) Using serpentine belt tension gauge, tighten adjusting bolt until belt reaches proper tension. Refer to Belt Tension at the rear of this section for proper belt tension.
- (4) Tighten alternator upper and lower mounting bolts.
- (5) After generator and adjust bracket have been tightened into position, recheck belt tension. Adjust if necessary.

## COOLING SYSTEM FANS

### REMOVAL

Some engines have the mechanical fan/viscous fan drive assembly mounted directly to the water pump hub (Fig. 55). It may also be mounted to a hub/bearing attached to an aluminum bracket on the right front side of engine (Fig. 56).

- (1) Loosen but do not remove at this time, the four fan hub mounting nuts (Fig. 55) (Fig. 56).
- (2) Remove accessory serpentine drive belt. Refer to Belt Service in the Engine Accessory Drive Belt section of this group.
- (3) Some models with certain engines may require the removal of the fan shroud to remove the viscous fan drive. The fan shroud and fan blade/viscous fan

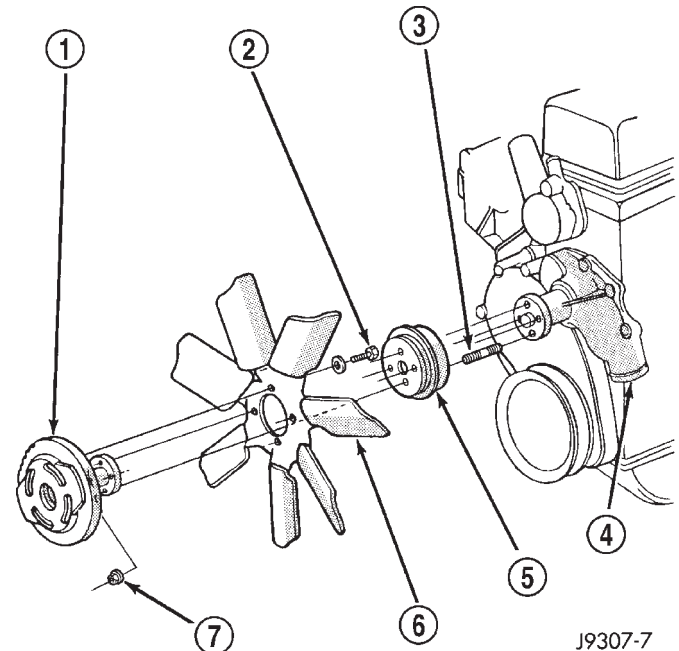

**Fig. 55 Water Pump Mounted Cooling Fan**

- 1 - THERMAL VISCOUS FAN DRIVE  
2 - (4) FAN BLADE-TO-VISCOUS DRIVE BOLTS  
3 - (4) FAN HUB-TO-PUMP PULLEY STUDS  
4 - WATER PUMP  
5 - WATER PUMP PULLEY  
6 - FAN BLADE  
7 - (4) FAN HUB-TO-PUMP PULLEY NUTS

drive should be removed from the vehicle as one assembly.

(4) Remove four fan hub mounting nuts (Fig. 55) (Fig. 56) and remove fan/viscous fan drive assembly from vehicle.

(5) After removing fan blade/viscous fan drive assembly, **do not** place thermal viscous fan drive in horizontal position. If stored horizontally, silicone fluid in viscous fan drive could drain into its bearing assembly and contaminate lubricant.

### INSTALLATION

(1) Assemble fan blade to viscous fan drive. Tighten mounting bolts to 27 N·m (20 ft. lbs.) torque.

(2) Position mounting flange of fan blade/viscous fan drive assembly onto hub. Install four nuts and tighten to 24 N·m (18 ft. lbs.) torque. Tighten the first two nuts 180 degrees apart. Then tighten last two nuts.

**CAUTION:** When installing a serpentine accessory drive belt, the belt **MUST** be routed correctly. If not, the engine may overheat due to the water pump rotating in the wrong direction. Refer to appropriate Engine Accessory Drive Belt Schematic in this group for correct belt routing.



## REMOVAL AND INSTALLATION (Continued)

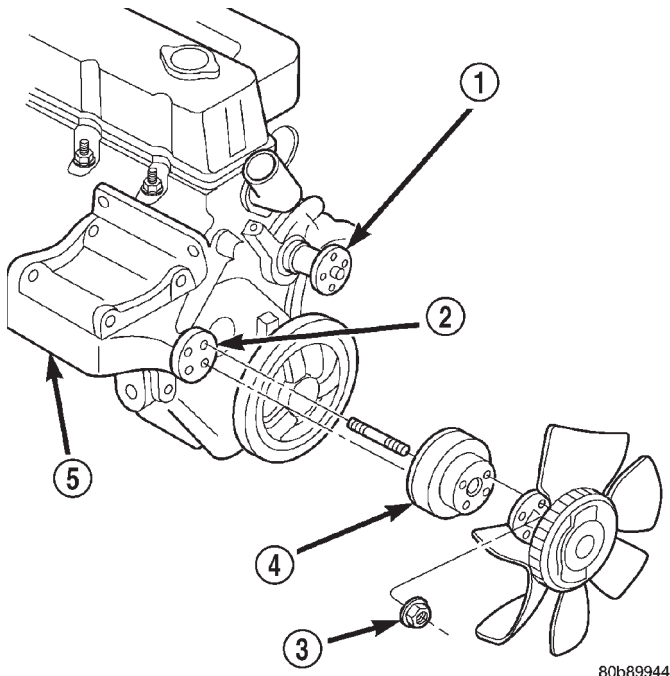

**Fig. 56 Bracket Mounted Cooling Fan**

- 1 - WATER PUMP (2.5L ENGINE)
- 2 - HUB/BEARING (4.0L ENGINE)
- 3 - PULLEY NUTS
- 4 - PULLEY
- 5 - BRACKET

(3) Install accessory drive belts. Tension belts to specifications. Refer to the Specifications section at the end of this group.

### VISCOUS FAN DRIVE REMOVAL/INSTALLATION

Refer to Cooling System Fan for removal and installation procedures of the viscous drive unit.

#### Viscous Fan Drive Fluid Pump Out Requirement:

After installing a **new** viscous fan drive, bring the engine speed up to approximately 2000 rpm and hold for approximately two minutes. This will ensure proper fluid distribution within the drive.

## CLEANING AND INSPECTION

### RADIATOR PRESSURE CAP

#### CLEANING

Clean the radiator pressure cap using a mild soap and water only.

#### INSPECTION

Visually inspect the pressure valve gasket on the cap. Replace cap if the gasket is swollen, torn or worn. Inspect the area around radiator filler neck for white deposits that indicate a leaking cap.

## RADIATOR

### CLEANING

Clean radiator fins With the engine cold, apply cold water and compressed air to the back (engine side) of the radiator to flush the radiator and/or A/C condenser of debris.

### INSPECTION

The radiator cooling fins should be checked for damage or deterioration. Inspect cooling fins to make sure they are not bent or crushed, these areas result in reduced heat exchange causing the cooling system to operate at higher temperatures. Inspect the plastic end tanks for cracks, damage or leaks.

Inspect the radiator neck for damage or distortion.

## WATER PUMP

### CLEANING

Clean the gasket mating surface. Use caution not to damage the gasket sealing surface.

### INSPECTION

Inspect the water pump assembly for cracks in the housing, Water leaks from shaft seal, Loose or rough turning bearing or Impeller rubbing either the pump body or timing chain case/cover.

## FAN BLADE

### CLEANING

Clean the fan blades using a mild soap and water. Do not use an abrasive to clean the blades.

### INSPECTION

**WARNING: DO NOT ATTEMPT TO BEND OR STRAIGHTEN FAN BLADES IF FAN IS NOT WITHIN SPECIFICATIONS.**

**CAUTION: If fan blade assembly is replaced because of mechanical damage, water pump and viscous fan drive should also be inspected. These components could have been damaged due to excessive vibration.**

(1) Remove fan blade assembly from viscous fan drive unit (four bolts).

(2) Lay fan on a flat surface with leading edge facing down. With tip of blade touching flat surface, replace fan if clearance between opposite blade and surface is greater than 2.0 mm (.090 inch). Rocking motion of opposite blades should not exceed 2.0 mm (.090 inch). Test all blades in this manner.

CLEANING AND INSPECTION (Continued)

(3) Inspect fan assembly for cracks, bends, loose rivets or broken welds. Replace fan if any damage is found.

COOLING SYSTEM HOSES

INSPECTION

Inspect the hoses at regular intervals. Replace hoses that are cracked, feel brittle when squeezed or swell excessively when the system is pressurized. The use of molded replacement hoses is recommended. When performing a hose inspection, inspect the radiator lower hose for proper position and condition of the spring.

SPECIFICATIONS

BELT TENSION

Belt tension must be adjusted. Refer to the following Belt Tension chart for specifications.

DESCRIPTION	N·f	Lbs. ft.
New Serpentine Belt*	800-900	180-200
Used Serpentine Belt	623-712	140-160
* Belt is considered new if it has been used 15 minutes or less.		

TORQUE SPECIFICATIONS

DESCRIPTION	N·m	Ft. Lbs.	In. Lbs.
Trans. Auxiliary Oil Cooler—Screws	2	—	18
Block Heater—Screw	4	—	20
Condenser-to-Radiator—Bolts	6	—	55
Electric Cooling Fan—Bolts	3	—	31
Fan Blade Assy to Viscous Fan Drive—Bolts	24	18	—
Fan Shroud—Bolts	3	—	31
Isolator-to-Crossmember—Nuts	10	—	86
Isolator-to-Radiator—Nuts	5	—	47
Radiator—Bolts			
4.0L Engine	8	—	70
2.5L Engine	6	—	55
Thermostat Housing—Bolts	20	15	—
Viscous Fan Drive Assy. to			

DESCRIPTION	N·m	Ft. Lbs.	In. Lbs.
Water Pump or Hub Bearing—Nuts	27	20	—
Water Pump—Bolts	23	17	—

SPECIAL TOOLS

COOLING

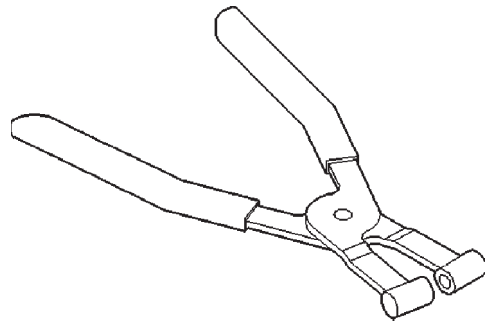

Hose Clamp Tool—6094

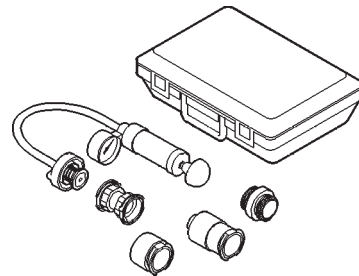

Cooling System Pressure Tester—7700A

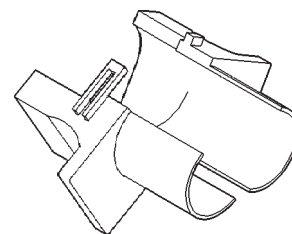

3/8" Quick Connect Release Tool—6935