

COOLING SYSTEM

TABLE OF CONTENTS

	page		page
DESCRIPTION AND OPERATION		SERVICE PROCEDURES	
COOLING SYSTEM	1	COOLANT LEVEL CHECK	18
RADIATOR	3	DRAINING COOLING SYSTEM	19
ENGINE ACCESSORY DRIVE BELT	3	REFILLING COOLING SYSTEM	19
COOLANT TANK	3	COOLANT REPLACEMENT	20
WATER PUMP	3	REMOVAL AND INSTALLATION	
COOLANT	3	RADIATOR	20
LOW COOLANT LEVEL SENSOR	3	FAN BLADE REMOVAL	21
THERMOSTAT	4	VISCOUS FAN DRIVE	22
PRESSURE/VENT CAP	4	THERMOSTAT	22
COOLANT PERFORMANCE	5	DRIVE BELT	23
COOLING SYSTEM HOSES	5	AUTOMATIC BELT TENSIONER	23
VISCOUS FAN DRIVE	6	WATER PUMP	23
BELT TENSION	7	CLEANING AND INSPECTION	
AUTOMATIC BELT TENSIONER	7	WATER PUMP	26
DIAGNOSIS AND TESTING		RADIATOR CLEANING	26
PRELIMINARY CHECKS	8	FAN BLADE	26
THERMOSTAT	14	PRESSURE/VENT CAP	27
VISCOUS FAN DRIVE	14	COOLING SYSTEM CLEANING/REVERSE FLUSHING	27
RADIATOR COOLANT FLOW CHECK	15	SPECIFICATIONS	
TESTING COOLING SYSTEM FOR LEAKS	15	COOLING SYSTEM CAPACITY	28
PRESSURE/VENT CAP	16	THERMOSTAT	28
LOW COOLANT LEVEL- AERATION	16	TORQUE SPECIFICATIONS	28
BELT DIAGNOSIS	17		

DESCRIPTION AND OPERATION

COOLING SYSTEM

DESCRIPTION

The cooling system regulates engine operating temperature. It allows the engine to reach normal operating temperature as quickly as possible, maintains normal operating temperature and prevents overheating.

The cooling system also provides a means of heating the passenger compartment. The cooling system is pressurized and uses a centrifugal water pump to circulate coolant throughout the system. A water manifold collects coolant from the cylinder heads. A separate and remotely mounted, pressurized coolant tank using a pressure/vent cap is used.

COOLING SYSTEM COMPONENTS

The cooling system consists of:

- Charge Air Cooler
- Electric Cooling Fan
- An aluminum radiator with plastic side tanks
- A radiator mounted fill vent valve
- A separate pressurized coolant tank
- A threaded-on, pressure/vent cap mounted to the coolant tank
- Cooling fan (mechanical)
- Thermal viscous fan drive
- Fan shroud
- Thermostat
- Coolant
- Low coolant level sensor
- Low coolant warning lamp
- Coolant temperature gauge
- Water pump
- Hoses and hose clamps

DESCRIPTION AND OPERATION (Continued)

COOLANT ROUTING

For cooling system flow routing, refer to (Fig. 1)

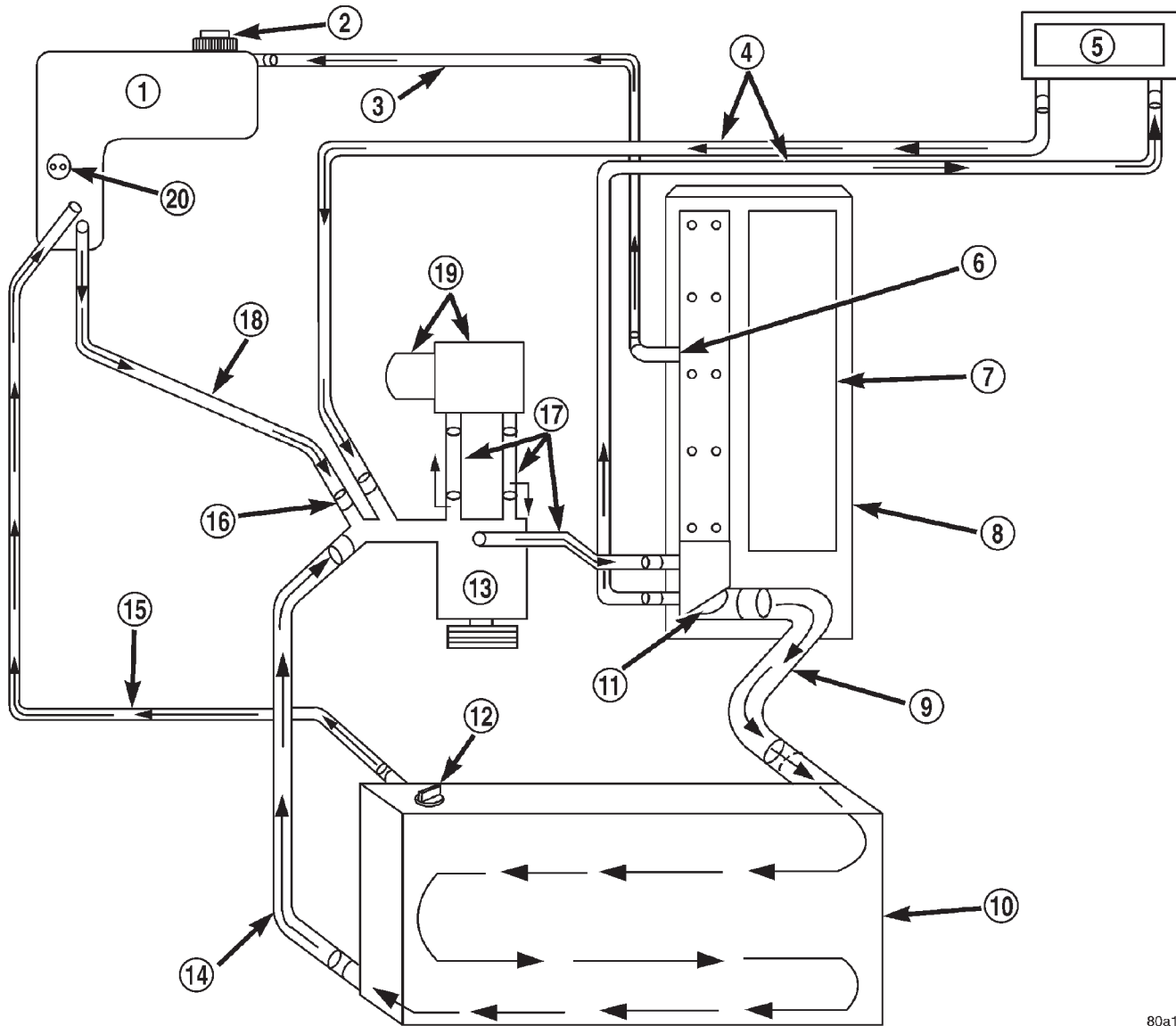

80a1386c

Fig. 1 Coolant Flow—2.5L Diesel Engine—Typical

- | | |
|---|-------------------------------------|
| 1 - PRESSURIZED COOLANT TANK | 11 - THERMOSTAT |
| 2 - PRESSURE/VENT CAP | 12 - FILL VENT CAP |
| 3 - HOSE | 13 - WATER PUMP |
| 4 - HEATER HOSES | 14 - LOWER RADIATOR HOSE |
| 5 - HEATER CORE | 15 - VENT HOSE |
| 6 - WATER MANIFOLD FITTING | 16 - LARGER FITTING TO COOLANT TANK |
| 7 - WATER MANIFOLD (TOP OF CYLINDER HEAD) | 17 - HOSES |
| 8 - ENGINE (TOP VIEW) | 18 - HOSE |
| 9 - UPPER RADIATOR HOSE | 19 - ENGINE OIL COOLER |
| 10 - RADIATOR | 20 - LOW COOLANT LEVEL SENSOR |

DESCRIPTION AND OPERATION (Continued)

RADIATOR**DESCRIPTION**

The radiator used with the 2.5L diesel is constructed of a horizontal flow aluminum core with plastic side tanks.

CAUTION: Plastic tanks, while stronger than brass, are subject to damage by impact, such as wrenches.

ENGINE ACCESSORY DRIVE BELT**DESCRIPTION**

The accessory drive components are operated by a single, crankshaft driven, serpentine drive belt. An automatic belt tensioner is used to maintain correct belt tension at all times.

CAUTION: When installing a serpentine accessory drive belt, the belt **MUST** be routed correctly. If not, the engine may overheat due to water pump rotating in wrong direction.

COOLANT TANK**DESCRIPTION**

A pressurized, plastic coolant tank is used with this cooling system (Fig. 2). The tank is located at the right-rear side of the engine compartment and is mounted as the highest point of the cooling system. This allows any air or vapor exceeding the pressure/vent cap rating to escape through the cap. Coolant flows through the tank at all times during engine operation whether the engine is cold or at normal operating temperature. The coolant tank is equipped with a threaded pressure/vent cap. Refer to Pressure/Vent Cap for additional information.

The low coolant level sensor is located near the bottom of the tank (Fig. 2).

WATER PUMP**DESCRIPTION**

A centrifugal water pump circulates coolant through the water jackets, passages, water manifold, radiator core, pressurized coolant tank, cooling system hoses and heater core. The pump is driven from the engine crankshaft by a drive belt. The water pump is bolted to the water pump adapter (Fig. 3). The water pump adapter is bolted to the engine.

The water pump impeller is pressed onto the rear of a shaft that rotates in bearings pressed into the housing. The bottom of the housing is equipped with a small vent tube (Fig. 3) to allow seepage to escape.

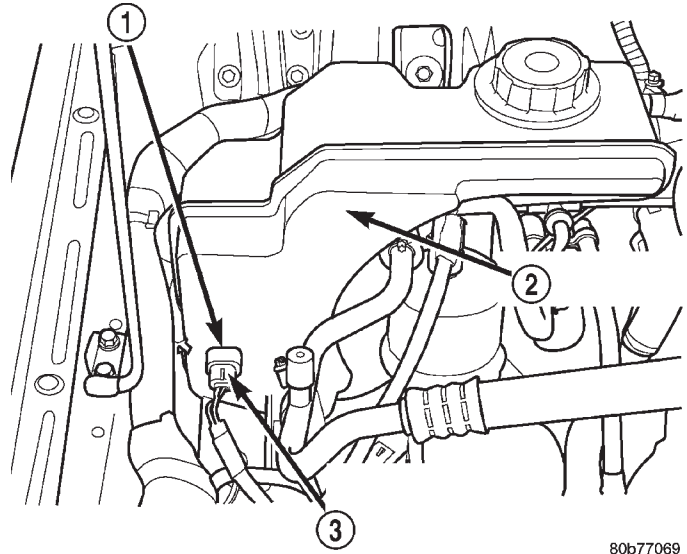

80b77069

Fig. 2 Pressurized Coolant Tank

- 1 - LOW COOLANT LEVEL SWITCH
- 2 - COOLANT RESERVOIR
- 3 - LOW COOLANT LEVEL SWITCH HARNESS CONNECTOR

A drain hose is attached to this tube. The water pump seals is lubricated by the antifreeze in the coolant mixture. No additional lubrication is necessary.

A rubber o-ring (instead of a gasket) is used as a seal between the water pump and the water pump adapter (Fig. 3).

A quick test to determine if the pump is working is to check if the heater warms properly. A defective water pump will not be able to circulate heated coolant through the heater hoses and the heater core.

COOLANT**DESCRIPTION**

Coolant flows through the engine water jackets and cylinder heads absorbing heat produced by the engine during operation. The coolant carries heat to the radiator and heater core. Here it is transferred to the ambient air passing through the radiator and heater core fins.

LOW COOLANT LEVEL SENSOR**DESCRIPTION**

The low coolant level sensor checks for low coolant level in the coolant tank (Fig. 4).

OPERATION

When the coolant level gets low a signal will be sent from this sensor to the powertrain control module (PCM). When the PCM determines low coolant level, the instrument panel mounted low coolant level warning lamp is illuminated. The sensor is located

DESCRIPTION AND OPERATION (Continued)

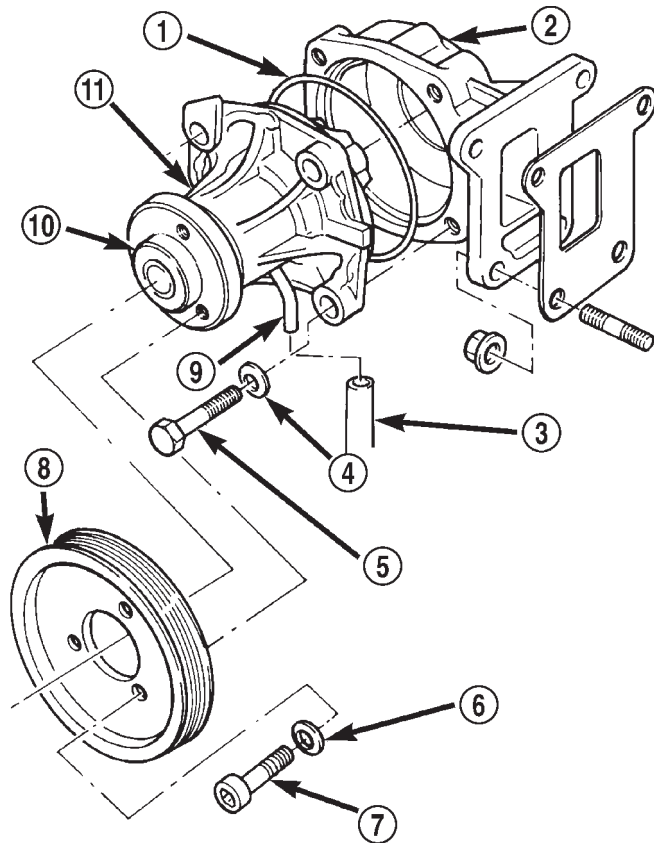

Fig. 3 Water Pump— Typical

- 1 - O-RING SEAL
- 2 - WATER PUMP ADAPTER
- 3 - DRAIN HOSE
- 4 - WASHER
- 5 - PUMP MOUNTING BOLTS (4)
- 6 - WASHER
- 7 - WATER PUMP PULLEY BOLTS (3)
- 8 - WATER PUMP PULLEY
- 9 - VENT TUBE
- 10 - PUMP HUB
- 11 - WATER PUMP

on the front of the coolant tank (Fig. 4). For information, refer to Group 8E, Instrument Panel and Gauges.

If this lamp is illuminated, it indicates the need for service.

THERMOSTAT

DESCRIPTION

A pellet-type thermostat controls the operating temperature of the engine by controlling the amount of coolant flow to the radiator.

OPERATION

The thermostat starts to open at 80°C (176°F). Above this temperature, coolant is allowed to flow to

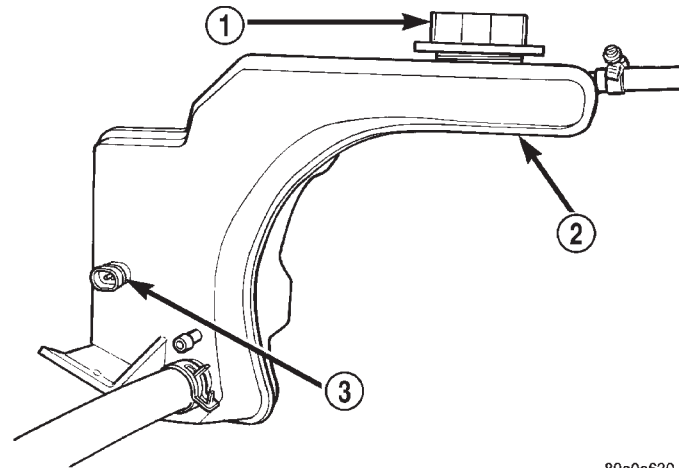

80a0c630

Fig. 4 Low Coolant Level Sensor

- 1 - PRESSURE/VENT CAP
- 2 - PRESSURIZED COOLANT TANK
- 3 - LOW COOLANT LEVEL SENSOR

the radiator. This provides quicker engine warmup and overall temperature control.

The same thermostat is used for winter and summer seasons. An engine should not be operated without a thermostat, except for servicing or testing. Operating without a thermostat causes other problems. These are: longer engine warmup time, unreliable warmup performance, increased exhaust emissions and crankcase condensation. This condensation can result in sludge formation.

CAUTION: Do not operate an engine without a thermostat, except for servicing or testing.

PRESSURE/VENT CAP

DESCRIPTION

The pressure/vent cap is threaded-on to the coolant tank. This cap releases excess pressure at some point within a range of 90-117 kPa (13- 17 psi). The actual pressure relief point (in pounds) is labeled on top of the cap (Fig. 5).

OPERATION

The cooling system will operate at pressures up to 103 kPa (15 psi). This results in a higher coolant boiling point allowing increased radiator cooling capacity. The cap (Fig. 5) contains a spring-loaded pressure relief valve. This valve opens when system pressure reaches approximately 103 kPa (15 psi).

When the engine is cooling down, vacuum is formed within the cooling system. To prevent collapse of the radiator and coolant hoses from this vacuum, a vacuum valve is used within the cap. This valve prevents excessive pressure differences from occurring

DESCRIPTION AND OPERATION (Continued)

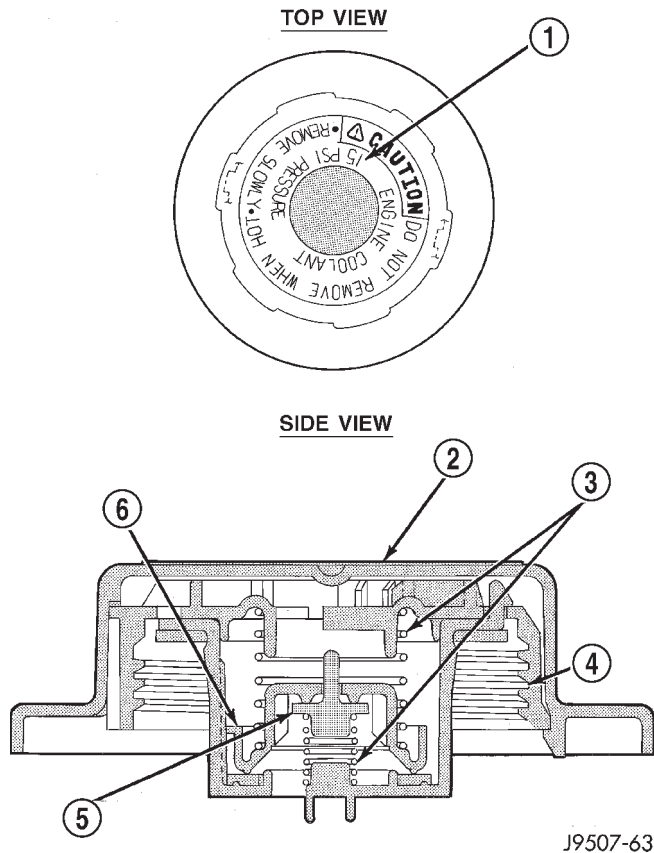

Fig. 5 Coolant Tank Pressure/Vent Cap

- 1 - RELEASE PRESSURE
- 2 - CAP COVER
- 3 - SPRING
- 4 - GASKET
- 5 - RUBBER VACUUM VALVE
- 6 - PRESSURE VALVE

between the closed cooling system and the atmosphere. If the vacuum valve is stuck shut, the radiator and/or cooling system hoses will collapse on cool-down.

NOTE: Do not use any type of tool when tightening the cap. Hand tighten only.

COOLANT PERFORMANCE

DESCRIPTION

The required ethylene-glycol (antifreeze) and water mixture depends upon the climate and vehicle operating conditions. The recommended mixture of 50/50 ethylene-glycol and water will provide protection against freezing to -37 deg. C (-35 deg. F). The antifreeze concentration **must always** be a minimum of 44 percent, year-round in all climates. **If percentage is lower than 44 percent, engine parts may be eroded by cavitation, and cooling system com-**

ponents may be severely damaged by corrosion. Maximum protection against freezing is provided with a 68 percent antifreeze concentration, which prevents freezing down to -67.7 deg. C (-90 deg. F). A higher percentage will freeze at a warmer temperature. Also, a higher percentage of antifreeze can cause the engine to overheat because the specific heat of antifreeze is lower than that of water.

100 Percent Ethylene-Glycol—Should Not Be Used in DaimlerChrysler Corporation Vehicles

Use of 100 percent ethylene-glycol will cause formation of additive deposits in the system, as the corrosion inhibitive additives in ethylene-glycol require the presence of water to dissolve. The deposits act as insulation, causing temperatures to rise to as high as 149 deg. C (300 deg. F). This temperature is hot enough to melt plastic and soften solder. The increased temperature can result in engine detonation. In addition, 100 percent ethylene-glycol freezes at 22 deg. C (-8 deg. F).

Propylene-glycol Formulations—Should Not Be Used in DaimlerChrysler Corporation Vehicles

Propylene-glycol formulations do not meet Chrysler coolant specifications. Its overall effective temperature range is smaller than that of ethylene-glycol. The freeze point of 50/50 propylene-glycol and water is -32 deg. C (-26 deg. F). 5 deg. C higher than ethylene-glycol's freeze point. The boiling point (protection against summer boil-over) of propylene-glycol is 125 deg. C (257 deg. F) at 96.5 kPa (14 psi), compared to 128 deg. C (263 deg. F) for ethylene-glycol. Use of propylene-glycol can result in boil-over or freeze-up in Chrysler vehicles, which are designed for ethylene-glycol. Propylene glycol also has poorer heat transfer characteristics than ethylene glycol. This can increase cylinder head temperatures under certain conditions.

Propylene-glycol/Ethylene-glycol Mixtures—Should Not Be Used in DaimlerChrysler Corporation Vehicles

Propylene-glycol/ethylene-glycol Mixtures can cause the destabilization of various corrosion inhibitors, causing damage to the various cooling system components. Also, once ethylene-glycol and propylene-glycol based coolants are mixed in the vehicle, conventional methods of determining freeze point will not be accurate. Both the refractive index and specific gravity differ between ethylene glycol and propylene glycol.

COOLING SYSTEM HOSES

DESCRIPTION

Rubber hoses route coolant to and from the radiator, and heater core.

DESCRIPTION AND OPERATION (Continued)

The radiator lower hose is spring-reinforced to prevent collapse from water pump suction at high engine speeds.

WARNING: CONSTANT TENSION HOSE CLAMPS ARE USED ON MOST COOLING SYSTEM HOSES. WHEN REMOVING OR INSTALLING, USE ONLY TOOLS DESIGNED FOR SERVICING THIS TYPE OF CLAMP (Fig. 6). ALWAYS WEAR SAFETY GLASSES WHEN SERVICING CONSTANT TENSION CLAMPS.

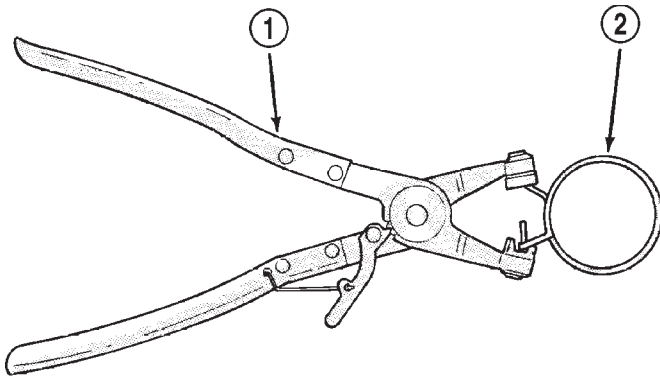

J9207-36

Fig. 6 Hose Clamp Tool

- 1 - HOSE CLAMP TOOL 6094
- 2 - HOSE CLAMP

CAUTION: A number or letter is stamped into the tongue of constant tension clamps (Fig. 7). If replacement is necessary, use only an original equipment clamp with matching number or letter.

Inspect the hoses at regular intervals. Replace hoses that are cracked, feel brittle when squeezed, or swell excessively when the system is pressurized.

For all vehicles: Be sure that hoses are positioned with sufficient clearance. Check clearance from exhaust manifolds and pipe, fan blades, drive belts and sway bars. Improperly positioned hoses can be damaged, resulting in coolant loss and engine overheating.

Ordinary worm gear type hose clamps (when equipped) can be removed with a straight screwdriver or a hex socket. **To prevent damage to hoses or clamps, the hose clamps should be tightened to 4 N·m (34 in. lbs.) torque. Do not over tighten hose clamps.**

When performing a hose inspection, inspect the radiator lower hose for proper position and condition of the internal spring.

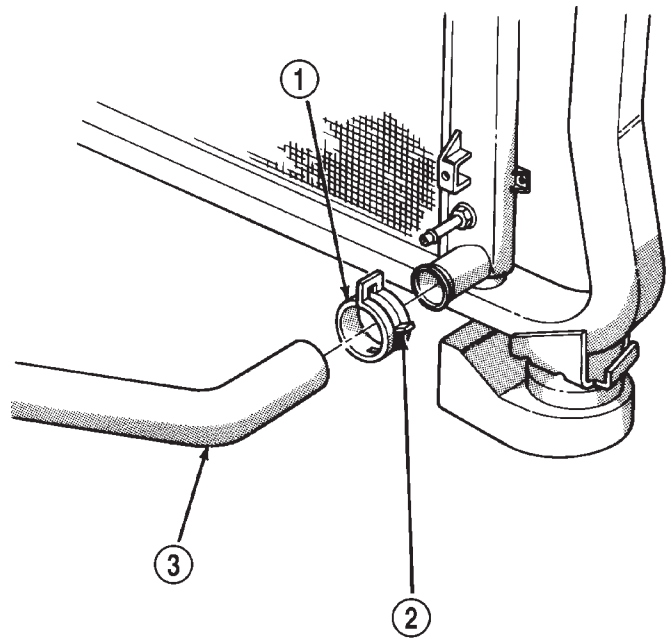

J9407-39

Fig. 7 Clamp Number/Letter Location

- 1 - TYPICAL CONSTANT TENSION HOSE CLAMP
- 2 - CLAMP NUMBER/LETTER LOCATION
- 3 - TYPICAL HOSE

VISCOUS FAN DRIVE

DESCRIPTION

The thermal viscous fan drive (Fig. 8) is a silicone-fluid-filled coupling. It connects the fan blade assembly to the fan pulley.

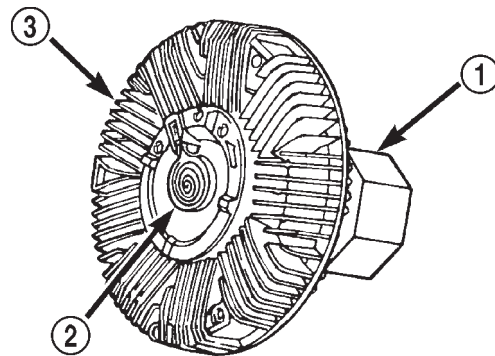

80a243e4

Fig. 8 Viscous Fan Drive

- 1 - MOUNTING NUT TO FAN PULLEY SHAFT
- 2 - THERMOSTATIC SPRING
- 3 - VISCOUS FAN DRIVE

OPERATION

The coupling allows the fan to be driven in a normal manner. This is done at low engine speeds while limiting the top speed of the fan to a predetermined maximum level at higher engine speeds. A bimetallic

DESCRIPTION AND OPERATION (Continued)

coil spring is located on the front face. This spring coil reacts to the temperature of the radiator discharge air. It engages the viscous fan drive for higher fan speed if the air temperature from the radiator rises above a certain point. Until additional engine cooling is necessary, the fan will remain at a reduced rpm regardless of engine speed.

The viscous fan drive will only engage when sufficient heat is present. This is when the air flowing through the radiator core causes a reaction from the bimetallic coil. It then increases fan speed to provide the necessary additional engine cooling.

Once the engine has cooled, the radiator discharge temperature will drop. The bimetallic coil again reacts and the fan speed is reduced to the previous disengaged speed.

CAUTION: Some engines equipped with serpentine drive belts have reverse rotating fans and viscous fan drives. They are marked with the word **REVERSE** to designate their usage. Installation of the wrong fan or viscous fan drive can result in engine overheating.

NOISE

NOTE: It is normal for fan noise to be louder (roaring) when:

- The underhood temperature is above the engagement point for the viscous drive coupling. This may occur when ambient (outside air temperature) is very high.
- Engine loads and temperatures are high such as when towing a trailer.
- Cool silicone fluid within the fan drive unit is being redistributed back to its normal disengaged (warm) position. This can occur during the first 15 seconds to one minute after engine start-up on a cold engine.

LEAKS

Viscous fan drive operation is not affected by small oil stains near the drive bearing. If leakage appears excessive, replace the fan drive unit.

BELT TENSION

DESCRIPTION

Correct accessory drive belt tension is required to be sure of optimum performance of belt driven engine accessories. If specified tension is not maintained, belt slippage may cause; engine overheating, lack of power steering assist, loss of air conditioning capacity, reduced generator output rate and greatly reduced belt life.

An automatic belt tensioner is used to maintain correct belt tension at all times. Do not attempt to check belt tension with a belt tension gauge on vehicles equipped with an automatic belt tensioner.

AUTOMATIC BELT TENSIONER

DESCRIPTION

Drive belt tension is controlled by a spring loaded automatic belt tensioner located below and to the front of the engine oil filter (Fig. 9).

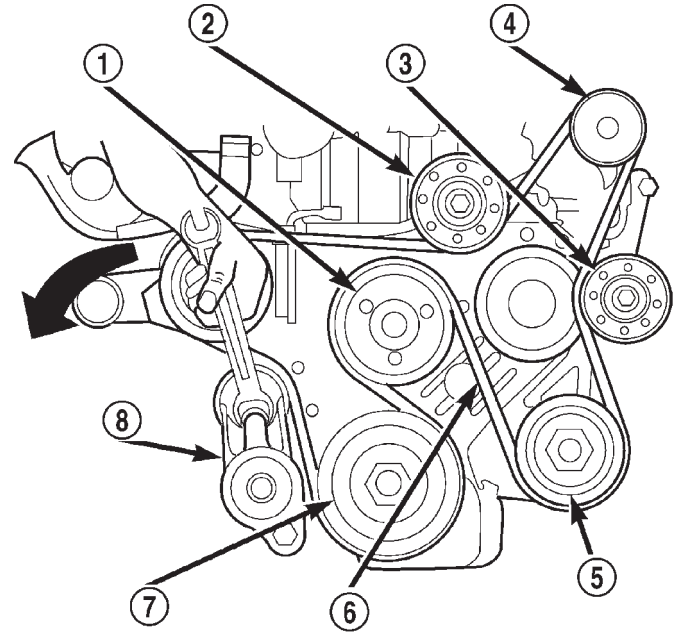

80bfe1c0

Fig. 9 Automatic Belt Tensioner Assembly

- 1 - FAN PULLEY
- 2 - IDLER PULLEY
- 3 - IDLER PULLEY
- 4 - GENERATOR
- 5 - POWER STEERING PUMP
- 6 - DRIVE BELT
- 7 - CRANKSHAFT PULLEY
- 8 - AUTOMATIC BELT TENSIONER

WARNING: BECAUSE OF HIGH SPRING PRESSURE, DO NOT ATTEMPT TO DISASSEMBLE THE AUTOMATIC BELT TENSIONER. UNIT IS SERVICED AS AN ASSEMBLY.

DIAGNOSIS AND TESTING

PRELIMINARY CHECKS

ENGINE COOLING SYSTEM OVERHEATING

Establish what driving conditions caused the complaint. Abnormal loads on the cooling system such as the following may be the cause:

(1) PROLONGED IDLE, VERY HIGH AMBIENT TEMPERATURE, SLIGHT TAIL WIND AT IDLE, SLOW TRAFFIC, TRAFFIC JAMS, HIGH SPEED OR STEEP GRADES.

Driving techniques that avoid overheating are:

- Idle with A/C off when temperature gauge is at end of normal range.
- Increasing engine speed for more air flow is recommended.

(2) TRAILER TOWING:

Consult Trailer Towing section of owners manual. Do not exceed limits.

(3) RECENT SERVICE OR ACCIDENT REPAIR:
Determine if any recent service has been performed on vehicle that may effect cooling system. This may be:

- Engine adjustments (incorrect timing)
- Slipping engine accessory drive belt
- Brakes (possibly dragging)
- Changed parts (incorrect water pump)
- Reconditioned radiator or cooling system refilling (possibly under filled or air trapped in system).

NOTE: If investigation reveals none of the previous items as a cause for an engine overheating complaint, refer to following Cooling System Diagnosis charts.

These charts are to be used as a quick-reference only. Refer to the group text for information.

COOLING SYSTEM DIAGNOSIS—DIESEL ENGINE

CONDITION	POSSIBLE CAUSES	CORRECTION
TEMPERATURE GAUGE READS LOW	<ol style="list-style-type: none"> 1. Diesel engines, due to their inherent efficiency are slower to warm up than gasoline powered engines, and will operate at lower temperatures when the vehicle is unloaded. 2. Is the temperature gauge connected to the temperature gauge coolant sensor on the engine? 3. Is the temperature gauge operating OK? 4. Coolant level low in cold ambient temperatures accompanied with poor heater performance. 5. Improper operation of internal heater doors or heater controls. 	<ol style="list-style-type: none"> 1. The low gauge reading may be normal. Refer to thermostats in the manual text for information. See Thermostat Diagnosis - Diesel Engine. 2. Check, the engine temperature sensor connector in the engine compartment. Refer to Group 8E. Repair as necessary. 3. Check gauge operation. Refer to Group 8E. Repair as necessary. 4. Check coolant level in the coolant tank. Inspect system for leaks. Repair leaks as necessary. Refer to the Coolant section of the manual text for WARNINGS and precautions before removing the pressure cap. 5. Inspect heater and repair as necessary. Refer to Group 24, Heating and Air Conditioning for procedures.

DIAGNOSIS AND TESTING (Continued)

CONDITION	POSSIBLE CAUSES	CORRECTION
<p>TEMPERATURE GAUGE READS HIGH. COOLANT MAY OR MAY NOT BE LOST OR LEAKING FROM COOLING SYSTEM</p>	<ol style="list-style-type: none"> 1. Trailer is being towed, a steep hill is being climbed, vehicle is operated in slow moving traffic, or engine is being idled with very high ambient (outside) temperatures and the air conditioning is on. Higher altitudes could aggravate these conditions. 2. Is temperature gauge reading correctly? 3. Coolant low in coolant tank and radiator? 4. Pressure cap not installed tightly. If cap is loose, boiling point of coolant will be lowered. Also refer to the following step 5. 5. Poor seals at pressure/vent cap. 6. Freeze point of antifreeze not correct. Mixture may be too rich. 	<ol style="list-style-type: none"> 1. This may be a temporary condition and repair is not necessary. Turn off the air conditioning and attempt to drive the vehicle without any of the previous conditions. Observe the temperature gauge. The gauge should return to the normal range. If the gauge does not return to normal range, determine the cause for overheating and repair. Refer to POSSIBLE CAUSES (numbers 2 through 16). 2. Check gauge. Refer to Group 8E. Repair as necessary. 3. Check for coolant leaks and repair as necessary. Refer to Testing Cooling System For Leaks in this group. 4. Tighten cap. 5. (a) Check condition of cap and cap seals. Refer to Pressure/Vent Cap. (b) Check condition of coolant tank filler neck. Make sure it does not leak pressure. 6. Check antifreeze. Refer to Coolant section of this group. Adjust antifreeze -to-water ratio as required.

DIAGNOSIS AND TESTING (Continued)

CONDITION	POSSIBLE CAUSES	CORRECTION
<p>TEMPERATURE GAUGE READS HIGH. COOLANT MAY OR MAY NOT BE LOST OR LEAKING FROM COOLING SYSTEM - CONT.</p>	<p>7. Coolant not flowing through system.</p> <p>8. Radiator or A/C condenser fins are dirty or clogged.</p> <p>9. Radiator core is corroded or plugged.</p> <p>10. Aftermarket A/C installed without proper A/C condenser.</p> <p>11. Dragging brakes.</p> <p>12. Non-factory bug screen is being used reducing airflow.</p> <p>13. Thermostat partially or completely shut. This is more prevalent on high mileage vehicles.</p> <p>14. Thermal viscous fan drive not operating properly.</p> <p>15. Cylinder head gasket leaking.</p> <p>16. Heater core leaking.</p>	<p>7. Check for coolant flow in coolant tank with engine warm and thermostat open. Coolant should be observed flowing through tank. If flow is not observed, determine reason for lack of flow and repair as necessary.</p> <p>8. Clean insects or debris. Refer to Radiator Cleaning in this group.</p> <p>9. Have radiator re-cored or replaced.</p> <p>10. Install proper A/C condenser.</p> <p>11. Check and correct as necessary. Refer to Group 5, Brakes in the manual text.</p> <p>12. Only a factory approved screen may be used.</p> <p>13. Check thermostat operation and replace as necessary. Refer to Thermostats in this group.</p> <p>14. Check fan drive operation and replace if necessary. Refer to Viscous Fan Drive in this group.</p> <p>15. Check for cylinder head gasket leaks. Refer to Testing Cooling System For Leaks in this group. For repair, refer to Group 9, Engines.</p> <p>16. Check heater core for leaks. Refer to Group 24, Heating and Air Conditioning. Repair as necessary.</p>

DIAGNOSIS AND TESTING (Continued)

CONDITION	POSSIBLE CAUSES	CORRECTION
<p>TEMPERATURE GAUGE READING IS INCONSISTENT (FLUCTUATES, CYCLES OR IS ERRATIC)</p>	<ol style="list-style-type: none"> 1. During cold weather operation, with the heater blower in the high position, the gauge reading may drop slightly. Fluctuation is also influenced by loads, outside temperature and extended idle time with diesel engines. 2. Temperature gauge or engine mounted gauge sensor defective or shorted. Also, corroded or loose wiring in this circuit. 3. Gauge reading rises when vehicle is brought to a stop after heavy use (engine still running). 4. Gauge reading high after restarting a warmed-up (hot) engine. 5. Coolant level low in coolant tank (air will build up in the cooling system causing the thermostat to open late). 6. Cylinder head gasket leaking allowing exhaust gas to enter cooling system causing thermostat to open late. 7. Water pump impeller loose on shaft. 8. Loose accessory drive belt (water pump slipping). 9. Air leak on the suction side of water pump allows air to build up in cooling system causing thermostat to open late. 	<ol style="list-style-type: none"> 1. A normal condition. No correction is necessary. 2. Check operation of gauge and repair if necessary. Refer to Group 8E, Instrument Panel And Gauges. 3. A normal condition. No correction is necessary. Gauge reading should return to normal range after vehicle is driven. 4. A normal condition. No correction is necessary. The gauge should return to normal range after a few minutes of engine operation. 5. Check and correct coolant leaks. Refer to Testing Cooling System For Leaks in this group. 6. (a) Check for cylinder head gasket leaks with a commercially available Block Leak Tester. Repair as necessary. (b) Check for coolant in the engine oil. Inspect for white steam emitting from exhaust system. Repair as necessary. 7. Check water pump and replace as necessary. Refer to Water Pumps in this group. 8. Refer to Engine Accessory Drive Belts in this group. Check and correct as necessary. Locate leak and repair as necessary.
<p>PRESSURE CAP IS BLOWING OFF STEAM AND/OR COOLANT. TEMPERATURE GAUGE READING MAY BE ABOVE NORMAL BUT NOT HIGH. COOLANT LEVEL MAY BE HIGH IN COOLANT TANK.</p>	<ol style="list-style-type: none"> 1. Pressure relief valve in pressure/vent cap is defective. 2. Major head gasket leak or cracked cylinder head. 	<ol style="list-style-type: none"> 1. Check condition of pressure/vent cap and cap seals. Refer to Pressure/Vent Caps in this group. Replace cap as necessary. 2. Refer to Engine group and repair as necessary.

DIAGNOSIS AND TESTING (Continued)

CONDITION	POSSIBLE CAUSES	CORRECTION
COOLANT LOSS TO THE GROUND WITHOUT PRESSURE CAP BLOWOFF. GAUGE IS READING HIGH OR HOT	1. Coolant leaks in radiator, cooling system hoses, water pump or engine.	1. Pressure test and repair as necessary. Refer to Testing Cooling System For Leaks in this group.
HOSE OR HOSES COLLAPSE WHEN ENGINE IS COOLING	1. Vacuum created in cooling system on engine cool-down is not being relieved through pressure/vent cap.	1. Cap relief valve stuck. Refer to Pressure/Vent Cap in this group. Replace if necessary.
NOISY FAN	<p>1. Fan blades loose.</p> <p>2. Fan blades striking a surrounding object.</p> <p>3. Air obstructions at radiator or air conditioning condenser.</p> <p>4. Thermal viscous fan drive has defective bearing.</p> <p>5. A certain amount of fan noise (roaring) may be evident on models equipped with a thermal viscous fan drive. Some of this noise is normal.</p>	<p>1. Replace fan blade assembly. Refer to Cooling System Fans in this group.</p> <p>2. Locate point of fan blade contact and repair as necessary.</p> <p>3. Remove obstructions and/or clean debris or insects from radiator or A/C condenser.</p> <p>4. Replace fan drive. Bearing is not serviceable. Refer to Viscous Fan Drive in this group.</p> <p>5. Refer to Viscous Fan Drive in this group for an explanation of normal fan noise.</p>
INADEQUATE AIR CONDITIONER PERFORMANCE (COOLING SYSTEM SUSPECTED)	<p>1. Radiator and/or A/C condenser is restricted, obstructed or dirty (insects, leaves etc.).</p> <p>2. Thermal viscous fan drive is freewheeling.</p> <p>3. Engine is overheating (heat may be transferred from radiator to A/C condenser. High underhood temperatures due to engine overheating may also transfer heat to A/C components).</p> <p>4. The cooling system is equipped with air seals at the radiator and/or A/C condenser. If these seals are missing or damaged, not enough air flow will be pulled through the radiator and A/C condenser.</p>	<p>1. Remove restriction and/or clean as necessary. Refer to Radiator Cleaning in this group.</p> <p>2. Refer to Viscous Fan Drive for diagnosis. Repair as necessary.</p> <p>3. Correct overheating condition. Refer to text in Group 7, Cooling.</p> <p>4. Check for missing or damaged air seals and repair as necessary.</p>

DIAGNOSIS AND TESTING (Continued)

CONDITION	POSSIBLE CAUSES	CORRECTION
<p>INADEQUATE HEATER PERFORMANCE. MAY BE ACCOMPANIED BY LOW GAUGE READING</p>	<ol style="list-style-type: none"> 1. Diesel engines, due to their inherent efficiency are slower to warm up than gasoline powered engines, and will operate at lower temperatures when the vehicle is unloaded. 2. Coolant level low. 3. Obstructions in heater hose fittings at engine. 4. Heater hose kinked. 5. Water pump is not pumping water to heater core. When the engine is fully warmed up, both heater hoses should be hot to the touch. If only one of the hoses is hotk the water pump may not be operating correctly. The accessory drive belt may also be slipping causing poor water pump operation. 	<ol style="list-style-type: none"> 1. The low gauge reading may be normal. Refer to Thermostats in the manual text for information. See Thermostat Diagnosis - Diesel Engine. 2. Refer to Testing Cooling System For Leaks in the manual text. Repair as necessary. 3. Remove heater hoses at both ends and check for obstructions. Repair as neccessary. 4. Located kinked area and repair as necessary. 5. Refer to Water Pumps in this group. Repair as necessary. If a slipping belt is detected, refer to Engine Accessory Drive Belts in this group. Repair as necessary.
<p>HEAT ODOR</p>	<ol style="list-style-type: none"> 1. Various heat shields are used at certain drive line components. One or more of these shields may be missing. 2. Is temperature gauge reading above the normal range? 3. Is cooling fan operating correctly? 4. Has undercoating been applied to any unnecessary component? 	<ol style="list-style-type: none"> 1. Locate missing shields and replace or repair as necessary. 2. Refer to the previous Temperature Gauge Reads High in these Diagnosis Charts. Repair as necessary. 3. Refer to Cooling System Fan in this group for diagnosis. Repair as necessary. 4. Clean undercoating as necessary.
<p>STEAM IS COMING FROM FRONT OF VEHICLE NEAR GRILL AREA WHEN WEATHER IS WET, ENGINE IS WARMED UP AND RUNNING, AND VEHICLE IS STATIONARY. TEMPERATURE GAUGE IS IN NORMAL RANGE</p>	<ol style="list-style-type: none"> 1. During wet weather, moisture (snow, ice or rain condensation) on the radiator will evaporate when the thermostat opens. This opening allows heated water into the radiator. When the moisture contacts the hot radiator, steam may be emitted. This usually occurs in cold weather with no fan or airflow to blow it away. 	<ol style="list-style-type: none"> 1. Occasional steam emitting from this area is normal. No repair is necessary.
<p>COOLANT COLOR</p>	<ol style="list-style-type: none"> 1. Coolant color is not necessarily an indication of adequate corrosion or temperatue protection. Do not rely on coolant color for determining condition of coolant. 	<ol style="list-style-type: none"> 1. Refer to Coolant in this group for antifreeze tests. Adjust antifreeze-to-water ratio as necessary.

DIAGNOSIS AND TESTING (Continued)

CONDITION	POSSIBLE CAUSES	CORRECTION
COOLANT LEVEL CHANGES IN COOLANT TANK. TEMPERATURE GAUGE IS IN NORMAL RANGE	1. Level changes are to be expected as coolant volume fluctuates with engine temperature. If the level in the tank was between the HOT and COLD marks at normal engine operating temperature, the level should return to within that range after operation at elevated temperatures.	1. A normal condition. No repair is necessary.

THERMOSTAT

DIAGNOSIS

Diesel engines, due to their inherent efficiency are slower to warm up than gasoline powered engines, and will operate at lower temperatures when the vehicle is unloaded. Because of this, lower temperature gauge readings for diesel versus gasoline engines may, at times be normal.

TESTING

NOTE: The DRB scan tool cannot be used to monitor engine coolant temperature on the diesel engine.

(1) To determine if the thermostat is defective, it must be removed from the vehicle. Refer to Thermostats for removal and installation procedures.

(2) After the thermostat has been removed, examine the thermostat and inside of thermostat housing for contaminants. If contaminants are found, the thermostat may already be in a "stuck open" position. Flush the cooling system before replacing thermostat. Refer to Cooling System Cleaning/Reverse Flushing in this group for additional information.

(3) Place the thermostat into a container filled with water.

(4) Place the container on a hot plate or other suitable heating device.

(5) Place a commercially available radiator thermometer into the water.

(6) Apply heat to the water while observing the thermostat and thermometer.

(7) When the water temperature reaches 80°C (176°F) the thermostat should start to open (valve will start to move). If the valve starts to move before this temperature is reached, it is opening too early. Replace thermostat. The thermostat should be fully open (valve will stop moving) at approximately 89°C (192°F). If the valve is still moving after the water temperature reaches this temperature, it is opening too late. Replace thermostat.

(8) If the valve refuses to move at any time, replace thermostat.

VISCOUS FAN DRIVE

TESTING

If the fan assembly free-wheels without drag (the fan blades will revolve more than five turns when spun by hand), replace the fan drive. This spin test must be performed when the engine is cool.

The cooling system must be in good condition. This is checked prior to performing the following test. It also will ensure against excessively high coolant temperature.

WARNING: BE SURE OF ADEQUATE FAN BLADE CLEARANCE BEFORE DRILLING.

(1) Drill a 3.12-mm (1/8-in) diameter hole in the top center of the fan shroud.

(2) Obtain a dial thermometer with an 8 inch stem (or equivalent). It should have a range of -18° to 105°C (0° to 220° F). Insert thermometer through the hole in the shroud. Be sure that there is adequate clearance from the fan blades.

(3) Block the air flow through the radiator. Secure a sheet of plastic in front of the radiator (or air conditioner condenser). Use tape at the top to secure the plastic and be sure that the air flow is blocked.

(4) Be sure that the air conditioner (if equipped) is turned off.

WARNING: USE EXTREME CAUTION WHEN THE ENGINE IS OPERATING. DO NOT STAND IN A DIRECT LINE WITH THE FAN. DO NOT PUT YOUR HANDS NEAR THE PULLEYS, BELTS OR FAN. DO NOT WEAR LOOSE CLOTHING.

(5) Start the engine and operate at 2400 rpm. Within ten minutes the air temperature (indicated on the dial thermometer) should be up to 93° C (200° F). Fan drive **engagement** should have started to occur at between 82° to 91° C (180° to 195° F). Engagement is distinguishable by a definite **increase** in fan flow noise (roaring).

(6) When the air temperature reaches 93° C (200° F), remove the plastic sheet. Fan drive **disengagement** should have started to occur at between 57° to 79° C (135° to 175° F). A definite **decrease** of fan

DIAGNOSIS AND TESTING (Continued)

flow noise (roaring) should be noticed. If not, replace the defective viscous fan drive unit.

RADIATOR COOLANT FLOW CHECK

There is coolant flow through the coolant tank (bottle) before and after the thermostat opens.

CAUTION: Do not remove the vent valve to insert a temperature gauge through the opening, coolant will spill out of the system and the engine will not be filled with coolant up to the heads. Major damage could happen if you run the engine in this condition.

TESTING COOLING SYSTEM FOR LEAKS

ULTRAVIOLET LIGHT METHOD

All Jeep[™] models have a leak detection additive added to the cooling system before they leave the factory. The additive is highly visible under ultraviolet light (black light). If the factory original coolant has been drained, pour one ounce of additive into the cooling system. The additive is available through the parts department. Place the heater control unit in HEAT position. Start and operate the engine until the radiator upper hose is warm to the touch. Aim the commercially available black light tool at the components to be checked. If leaks are present, the black light will cause the additive to glow a bright green color.

The black light can be used along with a radiator pressure tester to determine if any external leaks exist (Fig. 10).

PRESSURE TESTER METHOD

WARNING: HOT, PRESSURIZED COOLANT CAN CAUSE SERIOUS INJURY BY SCALDING. NEVER REMOVE THE PRESSURE/VENT CAP OR PRESSURE TESTER WHEN THE COOLING SYSTEM IS HOT OR UNDER PRESSURE!

Allow the engine to cool sufficiently so that the system is not under pressure and carefully remove the pressure/vent cap from the filler neck. Warm the engine with the pressure/vent cap off to normal operating temperature. With the engine turned off attach the cooling system pressure tester and test the system as described below.

Recheck the system cold if the cause of coolant loss is not located during warm engine examination.

A two-piece, threaded adapter set (Fig. 11) must be used to adapt a standard pressure-type tester (Fig. 12) when testing either the coolant tank or pressure cap. Use Kent-Moore[®] adapter set number J-24460-92 or Snap-On[®] numbers TA-32 and TA-33.

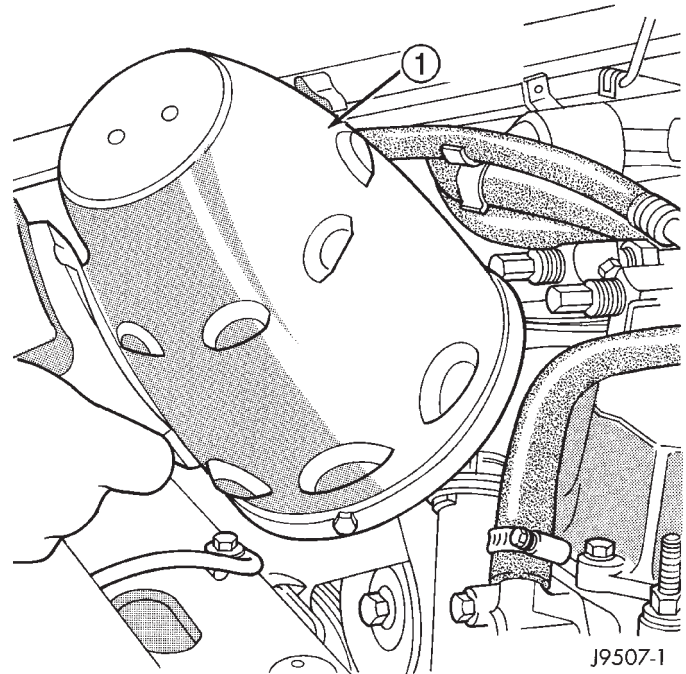

Fig. 10 Leak Detection Using Black Light—Typical
1 – TYPICAL BLACK LIGHT TOOL

Attach one of the adapters to the coolant pressure tank neck. Adapter must first be threaded to tank. Attach pressure tester to adapter.

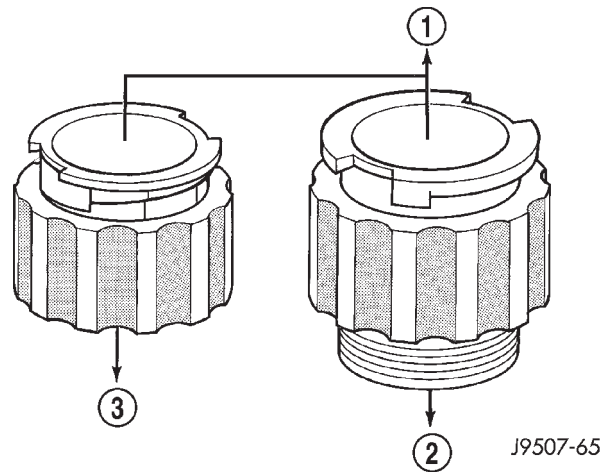
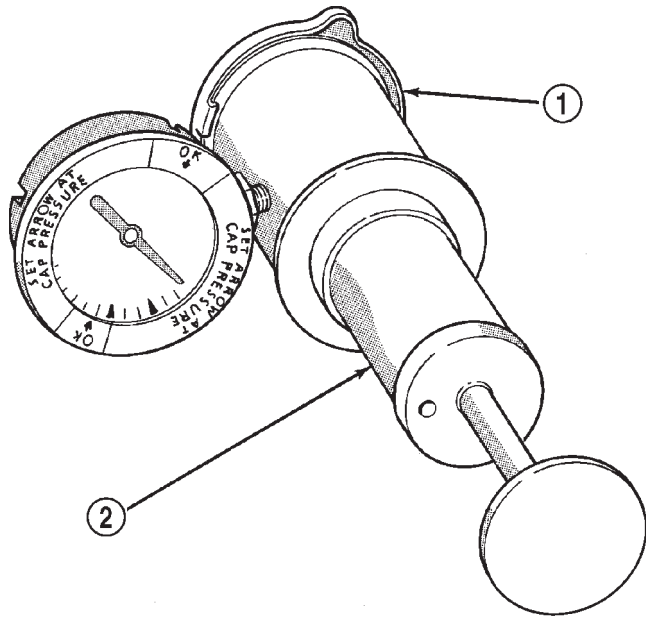

Fig. 11 Typical Pressure Tester Adapters

- 1 – TO PRESSURE TESTER
- 2 – TO CAP
- 3 – TO TANK

Operate the tester pump to apply 103 kPa (15 psi) pressure to the system. If the hoses enlarge excessively or bulge while testing, replace as necessary. Observe the gauge pointer and determine the condition of the cooling system according to the following criteria:

DIAGNOSIS AND TESTING (Continued)



J9507-3

Fig. 12 Typical Cooling System Pressure Tester

- 1 - PRESSURE CAP
2 - TYPICAL COOLING SYSTEM PRESSURE TESTER

- **Holds Steady:** If the pointer remains steady for two minutes, there are no serious coolant leaks in the system. However, there could be an internal leak that does not appear with normal system test pressure. Inspect for interior leakage or do the Internal Leakage Test. Do this if it is certain that coolant is being lost and no leaks can be detected.

- **Drops Slowly:** Shows a small leak or seepage is occurring. Examine all connections for seepage or slight leakage with a flashlight. Inspect the radiator, hoses, gasket edges and heater. Seal any small leak holes with a Sealer Lubricant or equivalent. Repair leak holes and reinspect the system with pressure applied.

- **Drops Quickly:** Shows that a serious leakage is occurring. Examine the system for serious external leakage. If no leaks are visible, inspect for internal leakage. Large radiator leak holes should be repaired by a reputable radiator repair shop.

INTERNAL LEAKAGE INSPECTION

Remove the oil pan drain-plug and drain a small amount of engine oil. Coolant, being heavier will drain first, or operate engine to churn oil, then examine dipstick for water globules. Operate the engine without the pressure/vent cap on the coolant tank until thermostat opens.

Attach a radiator pressure tester to the tank filler neck. If pressure builds up quickly, a leak exists as

result of a faulty cylinder head gasket or crack in the engine. Repair as necessary.

WARNING: DO NOT ALLOW PRESSURE TO EXCEED 117 KPA (17 PSI). TURN THE ENGINE OFF. TO RELEASE THE PRESSURE, ROCK THE TESTER FROM SIDE TO SIDE. WHEN REMOVING THE TESTER, DO NOT TURN THE TESTER MORE THAN 1/2 TURN IF THE SYSTEM IS UNDER PRESSURE.

If there is no immediate pressure increase, pump the pressure tester until the indicated pressure is within the system range. Vibration of the gauge pointer indicates compression or combustion leakage into the cooling system.

PRESSURE/VENT CAP

PRESSURE TESTING

Remove the cap from the coolant tank. Be sure that sealing surfaces are clean. Moisten rubber gasket with water.

A two-piece, threaded adapter set (Fig. 11) must be used to adapt a standard pressure-type tester (Fig. 12) when testing either the coolant tank or pressure cap. Use Kent-Moore® adapter set number J-24460-92 or Snap-On® numbers TA-32 and TA-33. Attach the adapter to the cap. Adapter must first be threaded to cap. Attach pressure tester to adapter.

Operate the tester pump and observe the gauge pointer at its highest point. The cap release pressure should be 90-to-117 kPa (13-to-17 psi). The cap is satisfactory when the pressure holds steady. It is also good if it holds pressure within the 90-to-117 kPa (13-to-17 psi) range for 30 seconds or more. If the pointer drops quickly, replace the cap.

CAUTION: Radiator pressure testing tools are very sensitive to small air leaks, which will not cause cooling system problems. A pressure cap that does not have a history of coolant loss should not be replaced just because it leaks slowly when tested with this tool. Add water to tool. Turn tool upside down and recheck pressure/vent cap to confirm that cap needs replacement.

LOW COOLANT LEVEL- AERATION

CAUTION: Engine damage could occur if the coolant level is allowed to get this low. Always ensure that the coolant level is not below the full mark. For better visibility of the coolant level use a shop lamp to light the pressurized coolant tank and look through the pressurized coolant tank.

DIAGNOSIS AND TESTING (Continued)

BELT DIAGNOSIS

When diagnosing serpentine accessory drive belts, small cracks that run across the ribbed surface of the belt from rib to rib (Fig. 13), are considered normal. These are not a reason to replace the belt. However, cracks running along a rib (not across) are **not** normal. Any belt with cracks running along a rib must be replaced (Fig. 13). Also replace the belt if it has excessive wear, frayed cords or severe glazing.

Refer to the Serpentine Drive Belt Diagnosis chart for further belt diagnosis.

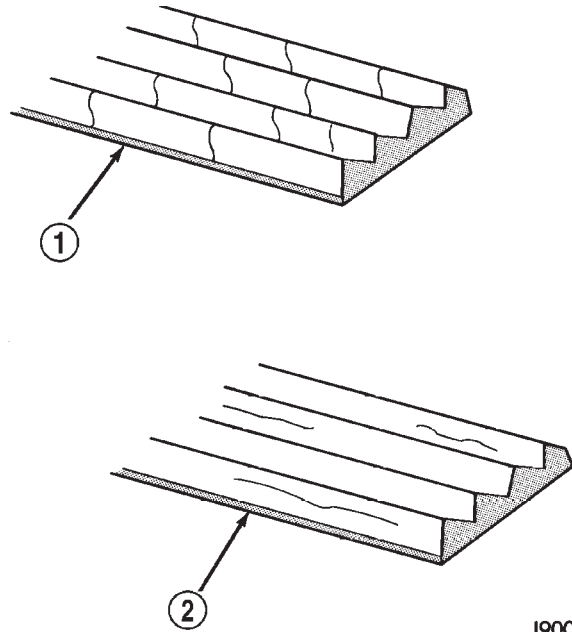

J9007-44

Fig. 13 Serpentine Belt Wear Patterns

- 1 - NORMAL CRACKS BELT OK
- 2 - NOT NORMAL CRACKS RELACE BELT

CONDITION	POSSIBLE CAUSES	CORRECTION
RIB CHUNKING (ONE OR MORE RIBS HAS SEPARATED FROM BELT BODY)	<ol style="list-style-type: none"> 1. Foreign objects imbedded in pulley grooves. 2. Installation damage. 	<ol style="list-style-type: none"> 1. Remove foreign objects from pulley grooves. Replace belt. 2. Replace belt.
RIB OR BELT WEAR	<ol style="list-style-type: none"> 1. Pulley(s) misaligned. 2. Abrasive environment. 3. Rusted pulley(s). 4. Sharp or jagged pulley groove tips. 5. Rubber deteriorated. 	<ol style="list-style-type: none"> 1. Align pulley(s). 2. Clean pulley(s). Replace belt if necessary. 3. Clean rust from pulley(s). 4. Replace pulley. 5. Replace belt.
LONGITUDINAL BELT CRACKING (CRACKS BETWEEN TWO RIBS)	<ol style="list-style-type: none"> 1. Belt has mistracked from pulley groove. 2. Pulley groove tip has worn away rubber to tensile member 	<ol style="list-style-type: none"> 1. Replace belt. 2. Replace belt.

DIAGNOSIS AND TESTING (Continued)

CONDITION	POSSIBLE CAUSES	CORRECTION
BELT SLIPS	<ol style="list-style-type: none"> 1. Belt slipping because of insufficient tension. 2. Incorrect belt. 3. Belt or pulley subjected to substance (belt dressing, oil, ethylene glycol) that has reduced friction. 4. Driven component bearing failure. 5. Belt glazed and hardened from heat and excessive slippage. 	<ol style="list-style-type: none"> 1. Replace automatic belt tensioner. 2. Replace belt. 3. Replace belt and clean pulleys. 4. Replace faulty component bearing. 5. Replace belt.
"GROOVE JUMPING" (BELT DOES NOT MAINTAIN CORRECT POSITION ON PULLEY)	<ol style="list-style-type: none"> 1. Belt tension either too high or too low. 2. Incorrect belt. 3. Pulley(s) not within design tolerance. 4. Foreign object(s) in grooves. 4. Pulley misalignment. 5. Belt cordline is broken. 	<ol style="list-style-type: none"> 1. Replace automatic belt tensioner. 2. Replace belt. Replace pulley(s). 4 Remove foreign objects from grooves. 4. Check and replace. 5. Replace belt.
BELT BROKEN (NOTE: IDENTIFY AND CORRECT PROBLEM BEFORE NEW BELT IS INSTALLED)	<ol style="list-style-type: none"> 1. Excessive tension. 2. Incorrect belt. 3. Tensile member damaged during belt installation. 4. Severe misalignment. 5. Bracket, pulley, or bearing failure. 	<ol style="list-style-type: none"> 1. Replace belt and automatic belt tensioner. 2. Replace belt. 3. Replace belt. 4. Check and replace. 5. Replace defective component and belt.
NOISE (OBJECTIONAL SQUEAL, SQUEAK, OR RUMBLE IS HEARD OR FELT WHILE DRIVE BELT IS IN OPERATION)	<ol style="list-style-type: none"> 1. Belt slippage. 2. Bearing noise. 3. Belt misalignment. 4. Belt-to-pulley mismatch. 	<ol style="list-style-type: none"> 1. Replace belt or automatic belt tensioner. 2. Locate and repair. 3. Replace belt. 4. Install correct belt.

SERPENTINE DRIVE BELT DIAGNOSIS

SERVICE PROCEDURES

COOLANT LEVEL CHECK

The coolant level is checked and adjusted at the pressurized coolant tank (Fig. 14). The tank is located at the right-rear side of the engine compartment and is mounted as the highest point of the cooling system. This will allow any air or vapor exceeding the pressure/vent cap rating to escape through the cap. The coolant tank is equipped with a

threaded-on pressure/vent cap. Refer to Pressure/Vent Cap for additional information.

A coolant reserve/overflow system with a separate tank is not used with the 2.5L diesel engine.

NOTE: The coolant level should be checked after the engine has been operated at normal operating temperature for approximately 5–10 minutes.

(1) Add coolant into the coolant tank up to the FULL mark. **If possible, only add coolant when the engine is cold. Coolant level in a warm**

SERVICE PROCEDURES (Continued)

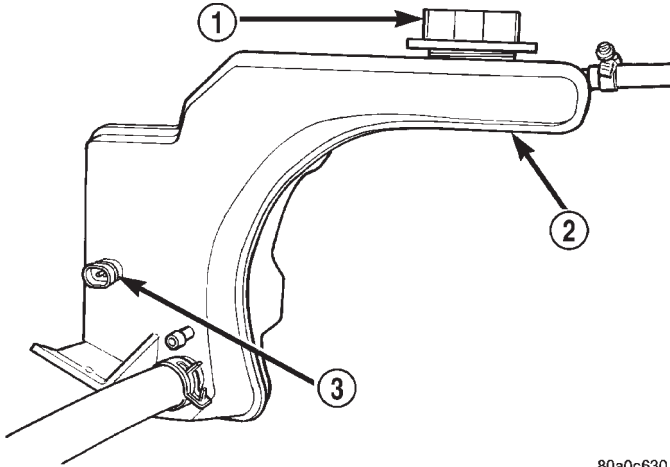

80a0c630

Fig. 14 Coolant Tank and Pressure/Vent Cap

- 1 - PRESSURE/VENT CAP
- 2 - PRESSURIZED COOLANT TANK
- 3 - LOW COOLANT LEVEL SENSOR

engine will be higher in the tank due to thermal expansion.

(2) After the engine has been operated through a few heat-up and cool-down cycles, recheck the coolant level in the tank.

DRAINING COOLING SYSTEM

The cooling system is equipped with a pressurized coolant tank using a pressure/vent cap.

WARNING: DO NOT REMOVE THE CYLINDER BLOCK DRAIN-PLUG, THE COOLANT TANK CAP, THE RADIATOR FILL VENT VALVE, OR LOOSEN THE RADIATOR DRAINCOCK WITH THE SYSTEM HOT AND PRESSURIZED. SERIOUS BURNS FROM THE COOLANT CAN OCCUR.

WARNING: IF VEHICLE HAS BEEN RUN RECENTLY, WAIT AT LEAST 15 MINUTES BEFORE REMOVING COOLANT TANK CAP. WITH A RAG, SQUEEZE THE UPPER RADIATOR HOSE TO CHECK IF SYSTEM IS UNDER PRESSURE. PLACE A RAG OVER THE CAP. VERY SLOWLY ROTATE THE CAP COUNTER-CLOCKWISE ALLOWING PRESSURE TO SLOWLY RELEASE. AFTER ALL PRESSURE HAS BEEN RELEASED, REMOVE THE COOLANT TANK CAP COMPLETELY.

DO NOT WASTE reusable coolant. If the solution is clean, drain the coolant into a clean container for reuse.

- (1) Observe the previous **WARNINGS** and remove the coolant tank pressure/vent cap.
- (2) The plastic radiator draincock is located on the bottom of the left radiator tank. It can be accessed by

removing the left front headlamp bezel and the radiator grille assembly from the bottom of vehicle.

(a) Attach one end of a 24 inch long X 1/4 inch ID drain-hose to the nipple below the radiator draincock.

(b) Put the other end of drain-hose into a clean container.

(c) Open the draincock (counterclockwise as viewed from left side of vehicle) and drain coolant from radiator.

(3) If the complete cooling system must be drained, raise the vehicle and remove the cylinder block drain-plug. This hex-headed plug is located on the right/rear side of the engine above the starter motor.

REFILLING COOLING SYSTEM

The cooling system is equipped with a pressurized coolant tank using a pressure/vent cap. Refilling of the system is done through this tank.

NOTE: The radiator draincock is equipped with a rubber o-ring. Do not over tighten draincock.

(1) Tighten the radiator draincock and (if removed), the cylinder block drain-plug.

(2) Open the plastic radiator fill vent valve (unscrews counter-clockwise) from the radiator. The fill vent valve is located on the top of the right radiator tank.

(3) With the fill vent valve open, proceed to fill the system using a 50/50 mixture of water and antifreeze as described in the Coolant section of this group.

(4) Continue to fill the cooling system until coolant is observed escaping from the fill vent opening. When this occurs, close the fill vent valve. **The plastic fill vent valve is equipped with a rubber o-ring. Do not over tighten the fill vent valve.**

(5) Continue to fill the system until the coolant tank is full.

(6) Install and tighten the coolant tank pressure/vent cap. **Do not use any type of tool when tightening the cap. Hand tighten only.**

(7) Operate engine with coolant tank cap tightened.

(8) After engine has reached normal operating temperature, shut engine off and allow it to cool.

(9) Remove coolant tank cap.

(10) Add coolant into the coolant tank up to the FULL mark. **If possible, only add coolant when the engine is cold. Coolant level in a warm engine will be higher in the tank due to thermal expansion.**

(11) After the engine has been operated through a few heat-up and cool-down cycles, recheck the coolant level in the tank.

SERVICE PROCEDURES (Continued)

COOLANT REPLACEMENT

It is recommended that the cooling system be drained and flushed at 84,000 kilometers (52,500 miles), or 3 years, whichever occurs first. Then every two years, or 48,000 kilometers (30,000 miles), whichever occurs first.

REMOVAL AND INSTALLATION

RADIATOR

WARNING: DO NOT REMOVE THE CYLINDER BLOCK DRAIN-PLUG, THE COOLANT TANK CAP, THE RADIATOR FILL VENT VALVE, OR LOOSEN THE RADIATOR DRAINCOCK WITH THE SYSTEM HOT AND PRESSURIZED. SERIOUS BURNS FROM THE COOLANT CAN OCCUR.

DO NOT WASTE reusable coolant. If solution is clean, drain coolant into a clean container for reuse.

WARNING: CONSTANT TENSION HOSE CLAMPS ARE USED ON MOST COOLING SYSTEM HOSES. WHEN REMOVING OR INSTALLING, USE ONLY TOOLS DESIGNED FOR SERVICING THIS TYPE OF CLAMP (Fig. 15). ALWAYS WEAR SAFETY GLASSES WHEN SERVICING CONSTANT TENSION CLAMPS.

CAUTION: A number or letter is stamped into the tongue of constant tension clamps (Fig. 16). If replacement is necessary, use only an original equipment clamp with matching number or letter.

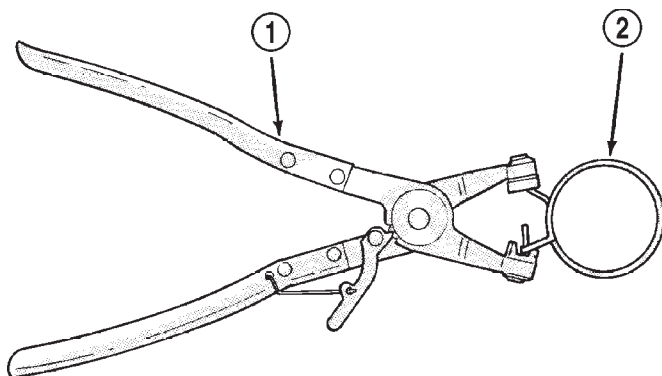

J9207-36

Fig. 15 Hose Clamp Tool

1 - HOSE CLAMP TOOL 6094

2 - HOSE CLAMP

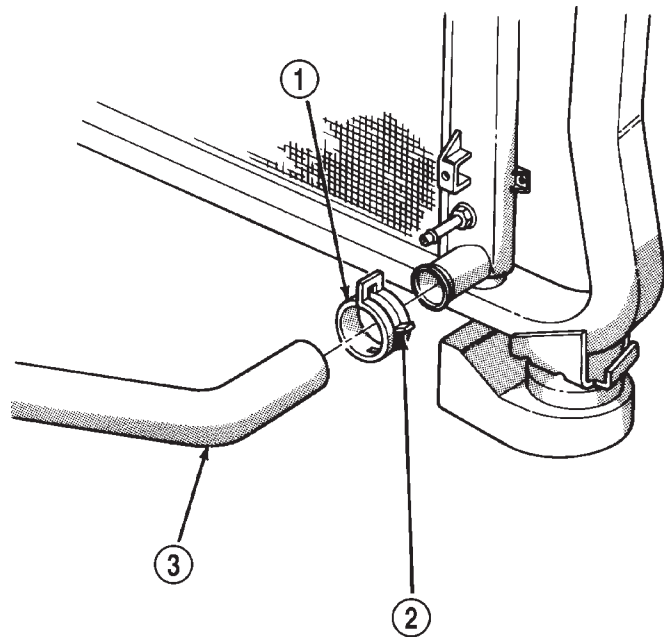

J9407-39

Fig. 16 Clamp Number/Letter Location

1 - TYPICAL CONSTANT TENSION HOSE CLAMP

2 - CLAMP NUMBER/LETTER LOCATION

3 - TYPICAL HOSE

REMOVAL

- (1) Disconnect negative battery cable at battery.
- (2) Observe the previous **WARNINGS**.
- (3) Drain cooling system. Refer to Draining Cooling System in this group.
- (4) Remove the upper fan shroud-to-upper cross-member mounting bolts. One of the bolts is mounted vertically at the bottom of the fan shroud.
- (5) Lift the fan shroud up until alignment tabs at the bottom are clear of slots in bracket at bottom of radiator. Slip the fan shroud rearward and position it over the fan blades.
- (6) Remove radiator hose clamps and remove radiator hoses.
- (7) Mark the position of the hood latch striker on the radiator crossmember and remove hood latch striker.
- (8) Remove radiator upper crossmember.
- (9) If equipped with air conditioning, separate the radiator from the A/C condenser by removing the condenser-to-radiator mounting brackets.
- (10) Lift radiator straight up and out of engine compartment taking care not to damage radiator or A/C condenser fins.

INSTALLATION

The radiator is equipped with two alignment dowels (Fig. 17). They are located on the bottom of the

REMOVAL AND INSTALLATION (Continued)

plastic side tanks and fit into rubber grommets located in the front lower crossmember.

(1) Carefully lower the radiator into engine compartment. Position the alignment dowels on the bottom of radiator into the rubber grommets in front lower crossmember (Fig. 17).

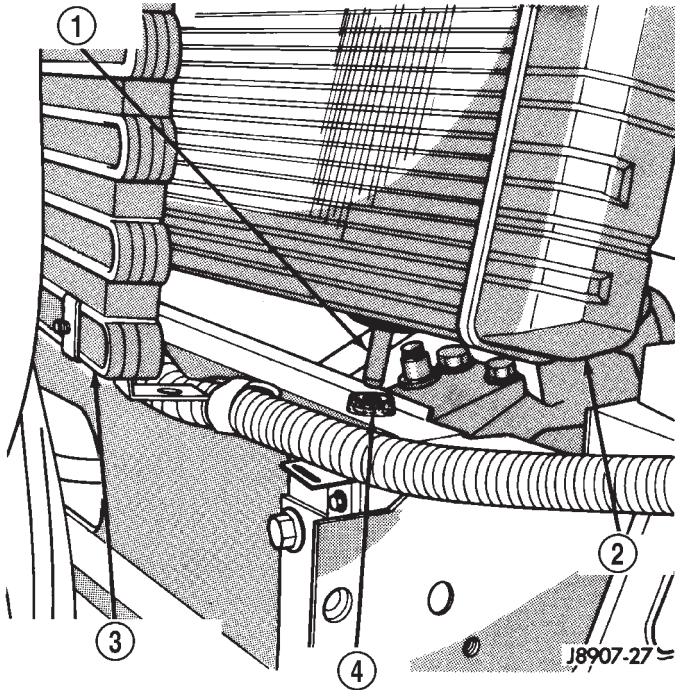

Fig. 17 Radiator Alignment Dowels—Typical

- 1 - ALIGNMENT DOWEL
- 2 - RADIATOR
- 3 - AIR CONDITIONING CONDENSER
- 4 - GROMMET

(2) If equipped with air conditioning, attach condenser to radiator with mounting brackets.

- (3) Install radiator upper crossmember.
- (4) Install hood latch striker.
- (5) Connect radiator upper and lower hoses.
- (6) Insert alignment tabs at bottom of fan shroud into slots in bracket at bottom of radiator. Install and tighten fan shroud bolts to 3 N·m (31 in. lbs.) torque.
- (7) Connect negative battery cable.
- (8) Fill cooling system with correct coolant. Refer to Refilling Cooling System in this group.
- (9) Start and warm the engine. Check for coolant leaks.

FAN BLADE REMOVAL

FAN BLADE REMOVAL

Accessory drive belt removal is not necessary for fan blade or viscous fan drive removal.

(1) Disconnect negative battery cable from battery.

(2) The thermal viscous fan drive/fan blade assembly is attached (threaded) to the fan pulley shaft (Fig. 18). Remove fan blade/viscous fan drive assembly from fan pulley by turning mounting nut counterclockwise as viewed from front. Threads on viscous fan drive are **RIGHT HAND**. Snap-On® 36 MM Fan Wrenches (number SP346) can be used to turn the mounting nut and to hold the fan pulley from rotating.

(3) Do not attempt to remove fan/viscous fan drive assembly from vehicle at this time.

(4) Do not unbolt fan blade assembly from viscous fan drive at this time.

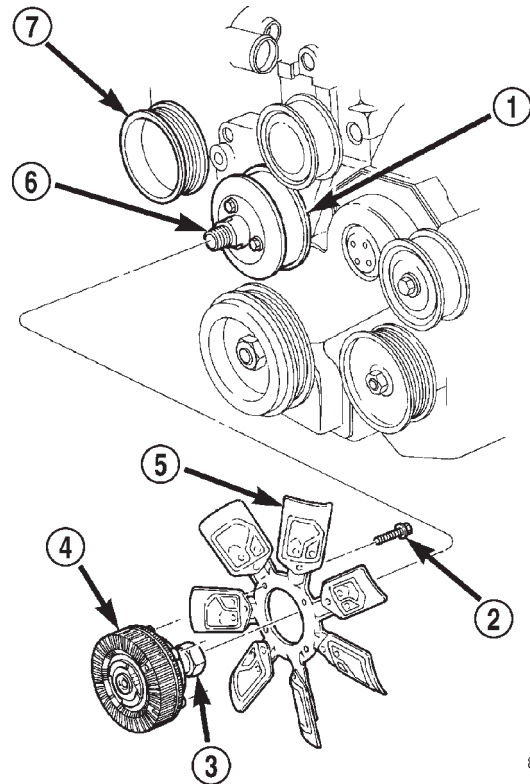

Fig. 18 Thermal Viscous Fan Drive and Blade Assembly

- 1 - FAN PULLEY
- 2 - FAN DRIVE-TO-FAN BLADE BOLTS (4)
- 3 - MOUNTING NUT
- 4 - THERMAL VISCIOUS FAN DRIVE
- 5 - FAN BLADES
- 6 - FAN PULLEY SHAFT
- 7 - WATER PUMP

80b89817

- (5) Remove the fan shroud mounting bolts.
- (6) Remove the fan shroud and fan blade/viscous fan drive assembly as a complete unit from vehicle.

(7) After removing fan blade/viscous fan drive assembly, **do not** place viscous fan drive in horizontal position. If stored horizontally, silicone fluid in the viscous fan drive could drain into its bearing assembly and contaminate lubricant.

REMOVAL AND INSTALLATION (Continued)

CAUTION: Do not attempt to remove the fan pulley bolts. The fan pulley is under tension from the drive belt.

(7) Remove four bolts securing fan blade assembly to viscous fan drive (Fig. 18).

FAN BLADE INSTALLATION

(1) Install fan blade assembly to viscous fan drive. Tighten bolts (Fig. 18) to 23 N·m (200 in. lbs.) torque.

(2) Position fan shroud and fan blade/viscous fan drive assembly to vehicle as a complete unit.

(3) Install and tighten fan shroud bolts to 3 N·m (31 in. lbs.) torque.

(4) Install fan blade/viscous fan drive assembly to fan pulley shaft (Fig. 18).

(5) Connect the negative battery cable.

VISCOUS FAN DRIVE

Refer to the FAN BLADE removal and installation procedure for replacement of the viscous fan drive.

The thermal viscous fan drive (Fig. 19) is a silicone-fluid-filled coupling. It connects the fan blade assembly to the fan pulley. The coupling allows the fan to be driven in a normal manner. This is done at low engine speeds while limiting the top speed of the fan to a predetermined maximum level at higher engine speeds. A bimetallic spring coil is located on the front face. This spring coil reacts to the temperature of the radiator discharge air. It engages the viscous fan drive for higher fan speed if the air temperature from the radiator rises above a certain point. Until additional engine cooling is necessary, the fan will remain at a reduced rpm regardless of engine speed.

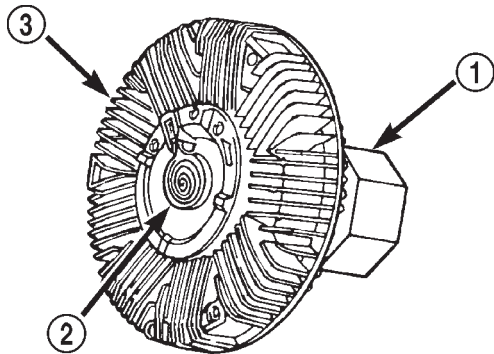

80a243e4

Fig. 19 Viscous Fan Drive

- 1 - MOUNTING NUT TO FAN PULLEY SHAFT
2 - THERMOSTATIC SPRING
3 - VISCOUS FAN DRIVE

The viscous fan drive will only engage when sufficient heat is present. This is when the air flowing through the radiator core causes a reaction from the

bimetallic coil. It then increases fan speed to provide the necessary additional engine cooling.

Once the engine has cooled, the radiator discharge temperature will drop. The bimetallic coil again reacts and the fan speed is reduced to the previous disengaged speed.

NOISE

NOTE: It is normal for fan noise to be louder (roaring) when:

- The underhood temperature is above the engagement point for the viscous drive coupling. This may occur when ambient (outside air temperature) is very high.
- Engine loads and temperatures are high such as when towing a trailer.
- Cool silicone fluid within the fan drive unit is being redistributed back to its normal disengaged (warm) position. This can occur during the first 15 seconds to one minute after engine start-up on a cold engine.

LEAKS

Viscous fan drive operation is not affected by small oil stains near the drive bearing. If leakage appears excessive, replace the fan drive unit.

THERMOSTAT

REMOVAL

WARNING: DO NOT REMOVE THE CYLINDER BLOCK DRAIN-PLUG, THE COOLANT TANK CAP, THE RADIATOR FILL VENT VALVE, OR LOOSEN THE RADIATOR DRAINCOCK WITH THE SYSTEM HOT AND PRESSURIZED. SERIOUS BURNS FROM THE COOLANT CAN OCCUR.

DO NOT WASTE reusable coolant. If the solution is clean, drain the coolant into a clean container for reuse.

(1) Drain the coolant from the radiator until the level is below the thermostat housing. Refer to Draining Cooling System for procedures.

WARNING: CONSTANT TENSION HOSE CLAMPS ARE USED ON MOST COOLING SYSTEM HOSES. WHEN REMOVING OR INSTALLING, USE ONLY TOOLS DESIGNED FOR SERVICING THIS TYPE OF CLAMP (Fig. 15). ALWAYS WEAR SAFETY GLASSES WHEN SERVICING CONSTANT TENSION CLAMPS.

REMOVAL AND INSTALLATION (Continued)

CAUTION: A number or letter is stamped into the tongue of constant tension clamps (Fig. 16). If replacement is necessary, use only an original equipment clamp with matching number or letter.

(2) Remove the upper radiator hose at the thermostat housing.

(3) Remove the four thermostat housing bolts (Fig. 20)

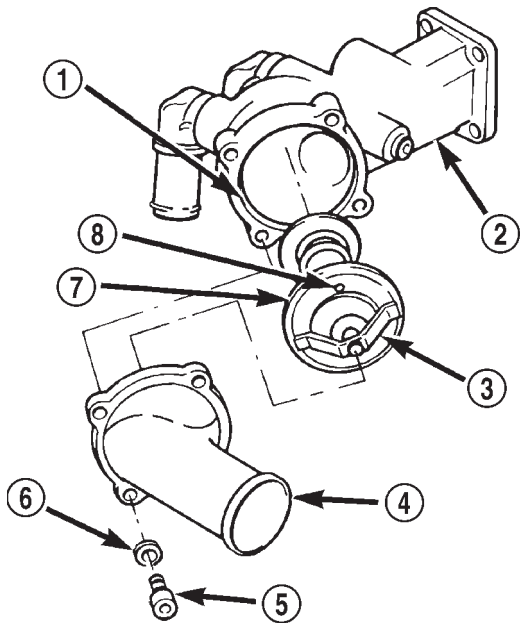

80a243e2

Fig. 20 Thermostat Removal/Installation

- 1 - THERMOSTAT RECESS GROOVE
- 2 - WATER MANIFOLD ADAPTER
- 3 - THERMOSTAT
- 4 - THERMOSTAT HOUSING
- 5 - HOUSING BOLTS (4)
- 6 - WASHER
- 7 - RUBBER SEAL
- 8 - VENT

(4) Remove the thermostat housing from the water manifold.

(5) Remove the thermostat and rubber seal from the water manifold.

(6) Thoroughly clean the rubber seal mating surfaces.

INSTALLATION

(1) Install a new rubber seal around the outer lip of the thermostat (a notch is provided in the rubber seal). Do not apply any adhesive to this seal.

(2) Install the replacement thermostat and rubber seal as one assembly into the water manifold adapter (the pointed end of the thermostat should be facing towards the front of engine (Fig. 20). Observe the recess groove in the water manifold adapter. Be sure

the thermostat vent is in the 12 o'clock position (Fig. 20).

(3) Position the thermostat housing and four bolts to the water manifold.

CAUTION: Tightening the thermostat housing unevenly or with the thermostat out of its recess groove, may result in a cracked housing.

(4) Tighten the four housing bolts to 11 N·m (98 in. lbs.) torque.

(5) Install radiator hose to thermostat housing.

(6) Be sure that the radiator drain is tightly closed. Fill the cooling system to the correct level with the required coolant mixture. Refer to Refilling Cooling System in this group for procedures.

(7) Start and warm the engine. Check thermostat and hose for leaks.

DRIVE BELT

CAUTION: The drive belt on the 2.5L diesel engine is equipped with a spring loaded automatic belt tensioner. After belt installation, do not attempt to check belt tension with a belt tension gauge.

AUTOMATIC BELT TENSIONER

WATER PUMP

REMOVAL

The water pump can be removed without discharging the air conditioning system (if equipped).

The water pump is serviced by replacing the pump and its impeller only. The water pump adapter (Fig. 22) does not have to be removed. The pump impeller is pressed on the rear of the pump shaft and bearing assembly. The pump is serviced only as a complete assembly with the impeller, housing, hub and bearing.

A rubber o-ring seal (instead of a gasket) is used as a seal between the water pump and the water pump adapter.

WARNING: DO NOT REMOVE THE CYLINDER BLOCK DRAIN-PLUG, THE COOLANT TANK CAP, THE RADIATOR FILL VENT VALVE, OR LOOSEN THE RADIATOR DRAINCOCK WITH THE SYSTEM HOT AND PRESSURIZED. SERIOUS BURNS FROM THE COOLANT CAN OCCUR.

DO NOT WASTE reusable coolant. If the solution is clean, drain coolant into a clean container for reuse.

(1) Disconnect the negative battery cable.

REMOVAL AND INSTALLATION (Continued)

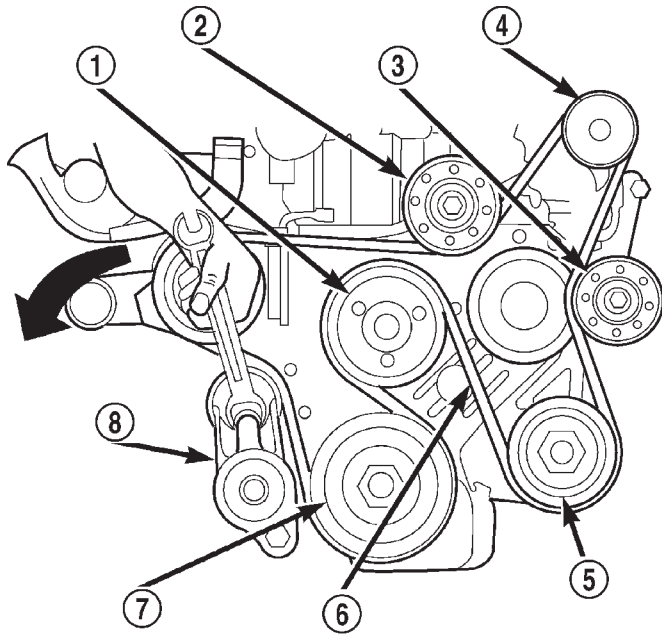

80bfe1c0

Fig. 21 Automatic Belt Tensioner Assembly

- 1 - FAN PULLEY
- 2 - IDLER PULLEY
- 3 - IDLER PULLEY
- 4 - GENERATOR
- 5 - POWER STEERING PUMP
- 6 - DRIVE BELT
- 7 - CRANKSHAFT PULLEY
- 8 - AUTOMATIC BELT TENSIONER

(2) Drain the cooling system. Refer to Draining Cooling System in this group.

(3) The thermal viscous fan drive and the fan blade assembly are attached (threaded) to the fan pulley shaft (Fig. 23). Remove the fan/fan drive assembly from the fan pulley by turning the mounting nut counterclockwise (as viewed from front). Threads on the fan drive are **RIGHT HAND**. Snap-On® 36 MM Fan Wrenches (number SP346) can be used to turn the mounting nut and to hold the fan pulley from rotating.

(4) If the water pump is being replaced, do not unbolt the fan blade assembly (Fig. 23) from the thermal viscous fan drive.

(5) Remove the upper fan shroud-to-upper cross-member mounting bolts. One of the bolts is mounted vertically at the bottom of the fan shroud.

(6) Slip the fan shroud rearward. Remove the fan shroud and viscous drive/fan blade together as one assembly from the engine compartment.

(7) Loosen **but do not remove** the 3 water pump pulley bolts (Fig. 22).

(8) Remove the drive belt by relieving the tension on the belt tensioner. For procedures, refer to Belt

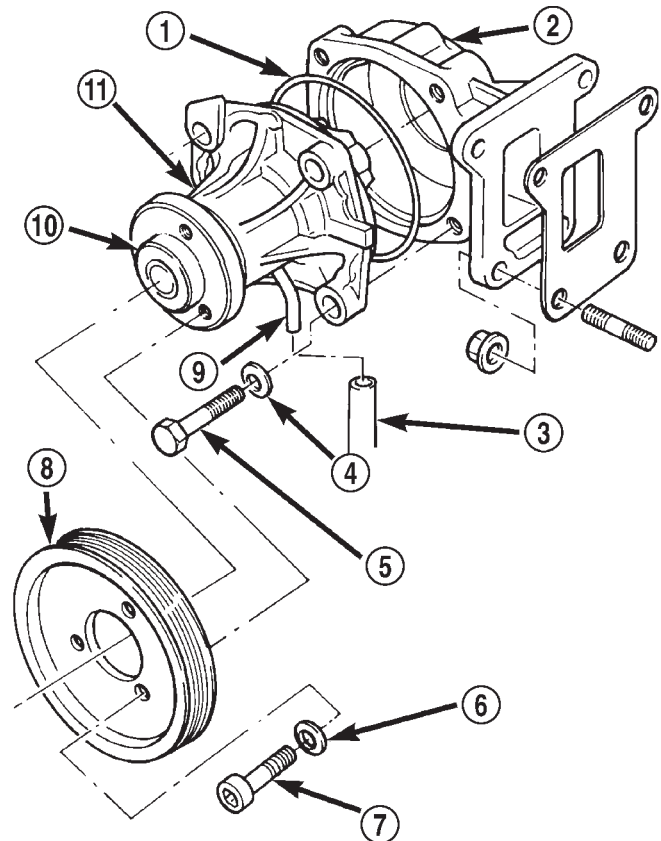

80a0c4e0

Fig. 22 WATER PUMP REMOVAL/INSTALL—TYPICAL

- 1 - O-RING SEAL
- 2 - WATER PUMP ADAPTER
- 3 - DRAIN HOSE
- 4 - WASHER
- 5 - PUMP MOUNTING BOLTS (4)
- 6 - WASHER
- 7 - WATER PUMP PULLEY BOLTS (3)
- 8 - WATER PUMP PULLEY
- 9 - VENT TUBE
- 10 - PUMP HUB
- 11 - WATER PUMP

Removal/Installation in the Engine Accessory Drive Belt section of this group.

WARNING: CONSTANT TENSION HOSE CLAMPS ARE USED ON MOST COOLING SYSTEM HOSES. WHEN REMOVING OR INSTALLING, USE ONLY TOOLS DESIGNED FOR SERVICING THIS TYPE OF CLAMP (Fig. 24). ALWAYS WEAR SAFETY GLASSES WHEN SERVICING CONSTANT TENSION CLAMPS.

CAUTION: A number or letter is stamped into the tongue of constant tension clamps (Fig. 25). If replacement is necessary, use only an original equipment clamp with matching number or letter.

REMOVAL AND INSTALLATION (Continued)

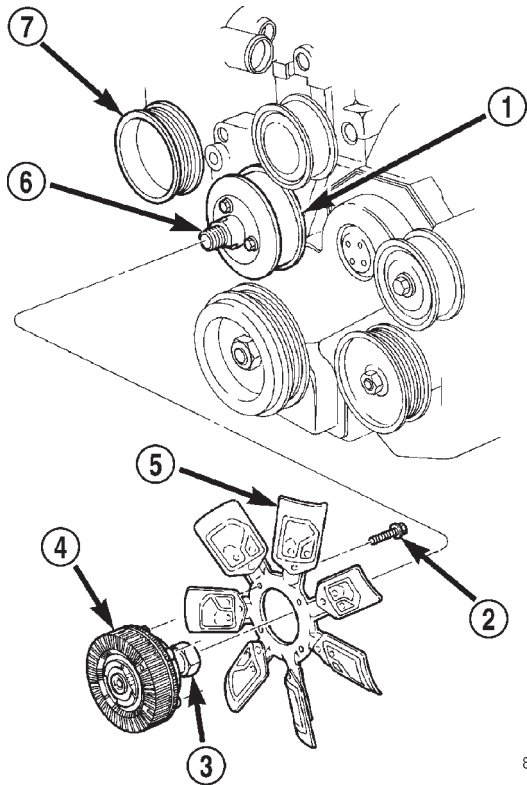

80b89817

Fig. 23 Thermal Viscous Fan Drive and Blade Assembly

- 1 - FAN PULLEY
- 2 - FAN DRIVE-TO-FAN BLADE BOLTS (4)
- 3 - MOUNTING NUT
- 4 - THERMAL VISCOUS FAN DRIVE
- 5 - FAN BLADES
- 6 - FAN PULLEY SHAFT
- 7 - WATER PUMP

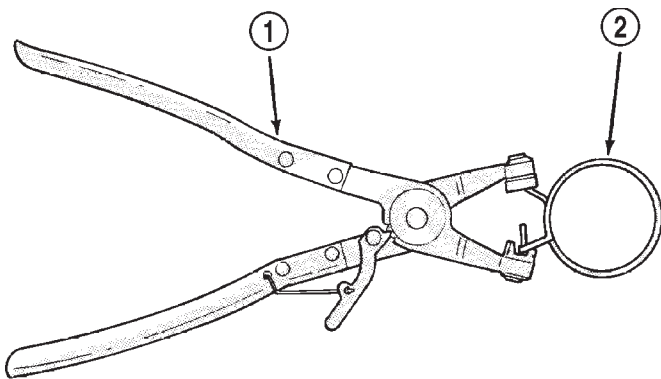

J9207-36

Fig. 24 Hose Clamp Tool

- 1 - HOSE CLAMP TOOL 6094
- 2 - HOSE CLAMP

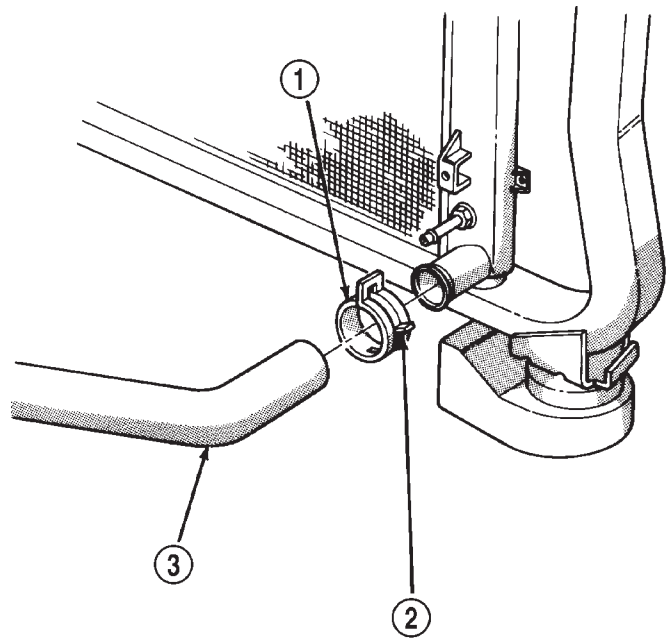

J9407-39

Fig. 25 Clamp Number/Letter Location

- 1 - TYPICAL CONSTANT TENSION HOSE CLAMP
- 2 - CLAMP NUMBER/LETTER LOCATION
- 3 - TYPICAL HOSE

(9) A metal coolant tube (used to connect rubber coolant hoses), and its mounting bracket are attached to the front of the water pump (Fig. 26). A rubber hose connects this tube to the engine. Disconnect the hose clamp and rubber hose at the back of the thermostat. Position the hose to the side.

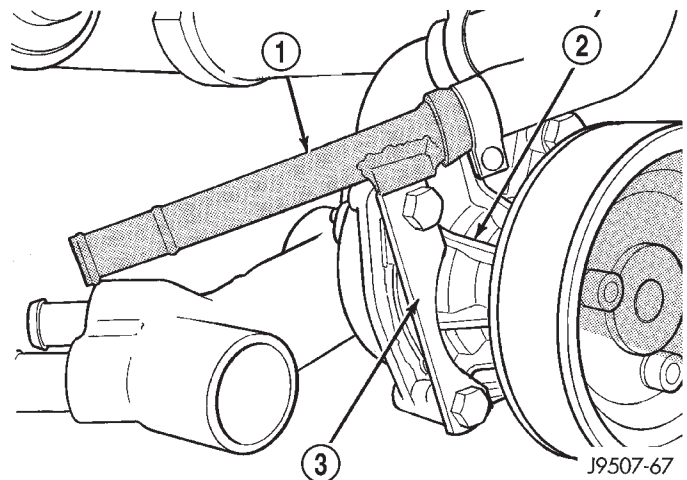

J9507-67

Fig. 26 Coolant Tube at Water Pump

- 1 - COOLANT TUBE
- 2 - WATER PUMP
- 3 - BRACKET

(10) Remove the 3 water pump pulley bolts (Fig. 22).

REMOVAL AND INSTALLATION (Continued)

- (11) Remove the water pump pulley from the water pump.
- (12) Disconnect the drain hose from the vent tube at the bottom of water pump (Fig. 22).
- (13) Remove the 4 water pump mounting bolts (Fig. 22).
- (14) Remove water pump from engine.

INSTALLATION

- (1) Clean the o-ring mating surfaces. If the original pump is to be reinstalled, remove any deposits or other foreign material. Inspect the water pump, water pump adapter and water pump mating surfaces for erosion or damage from cavitation.
- (2) Position a new rubber o-ring seal (Fig. 22) between the pump and pump adapter. Hold the seal with petroleum jelly.
- (3) Position the pump on the engine.
- (4) Position the metal coolant tube and its mounting bracket on the pump.
- (5) Install the four water pump mounting bolts. Torque bolts to 24 N·m (18 ft. lbs.).
- (6) Install drain hose to vent tube at bottom of pump.
- (7) Position the water pump pulley to the water pump.
- (8) Install the water pump pulley bolts finger tight.
- (9) Install the rubber coolant hose near the thermostat.
- (10) Install the accessory drive belt. For procedures, refer to Belt Removal/Installation in the Engine Accessory Drive Belt section of this group.
- (11) Torque the water pump pulley bolts to 24 N·m (18 ft. lbs.).
- (12) Position the viscous drive/fan blade and fan shroud to the engine compartment as one assembly.
- (13) Install the thermal viscous fan drive and fan blade to fan pulley. Torque to 56 N·m (41 ft. lbs.).
- (14) Install the fan shroud mounting bolts. Torque bolts to 3 N·m (31 in. lbs.).
- (15) Fill the cooling system with coolant and check for leaks. Refer to Refilling Cooling System in this group.
- (16) Connect the negative battery cable.
- (17) Start and warm the engine. Check for leaks.

CLEANING AND INSPECTION

WATER PUMP

INSPECTION

Replace the water pump assembly if it has any of the following conditions:

- The body is cracked or damaged

- Water leaks from the shaft seal. This is evident by traces of coolant below the vent tube drain hose
- Loose or rough turning bearing.
- Impeller rubs either the water pump body or water pump adapter.

RADIATOR CLEANING

The radiator and air conditioning fins should be cleaned when an accumulation of bugs, leaves etc. has occurred. Clean radiator fins are necessary for good heat transfer. With the engine cold, apply cold water and compressed air to the back (engine side) of the radiator to flush the radiator and/or A/C condenser of debris.

FAN BLADE

INSPECTION

The fan cannot be repaired. If fan is damaged, it must be replaced. Inspect fan as follows:

- (1) Remove fan blade and viscous fan drive as an assembly from the engine.
- (2) Remove fan blade assembly from viscous fan drive unit (four bolts) (Fig. 27).
- (3) Lay fan on a flat surface with leading edge facing down. With tip of blade touching flat surface, replace fan if clearance between opposite blade and surface is greater than 2.0 mm (.090 inch). Rocking motion of opposite blades should not exceed 2.0 mm (.090 inch). Test all blades in this manner.

WARNING: DO NOT ATTEMPT TO BEND OR STRAIGHTEN FAN BLADES IF NOT WITHIN SPECIFICATIONS.

- (4) Inspect fan assembly for cracks, bends, loose rivets or broken welds. Replace fan if any damage is found.

CAUTION: If fan blade assembly is replaced because of mechanical damage, the fan pulley bearing and viscous fan drive should also be inspected. These components could have been damaged due to excessive vibration.

CAUTION: Some engines equipped with serpentine drive belts have reverse rotating fans and viscous fan drives. They are marked with the word REVERSE to designate their usage. Installation of the wrong fan or viscous fan drive can result in engine overheating.

CLEANING AND INSPECTION (Continued)

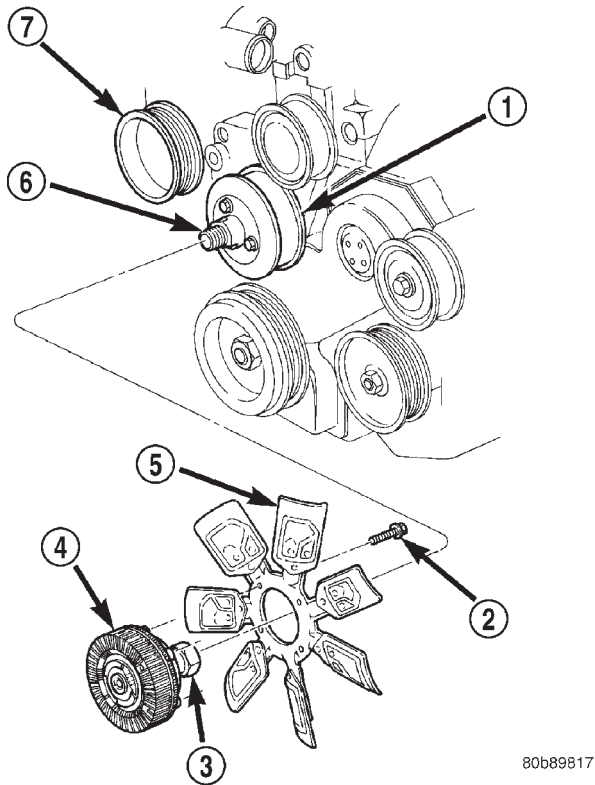

80b89817

Fig. 27 Thermal Viscous Fan Drive and Blade Assembly

- 1 – FAN PULLEY
- 2 – FAN DRIVE-TO-FAN BLADE BOLTS (4)
- 3 – MOUNTING NUT
- 4 – THERMAL VISCOUS FAN DRIVE
- 5 – FAN BLADES
- 6 – FAN PULLEY SHAFT
- 7 – WATER PUMP

PRESSURE/VENT CAP

INSPECTION

Visually inspect the gasket on the cap. Replace cap if the gasket is swollen, torn or worn. Inspect the area around the coolant tank filler neck for white deposits that indicate a leaking cap.

The cap must be replaced by a similar threaded-on unit with the correct operating pressures if replacement is necessary.

COOLING SYSTEM CLEANING/REVERSE FLUSHING

CAUTION: The cooling system normally operates at 90-to-117 kPa (13- to-17 psi) pressure. Exceeding this pressure may damage the radiator or hoses.

CLEANING

Drain cooling system and refill with water. Run engine with coolant tank pressure/vent cap installed until upper radiator hose is hot. Stop engine and drain water from system. If water is dirty, fill system with water, run engine and drain system. Repeat until water drains clean.

REVERSE FLUSHING

Reverse flushing of the cooling system is the forcing of water through the cooling system. This is done using air pressure in the opposite direction of normal coolant flow. It is usually only necessary with very dirty systems with evidence of partial plugging.

REVERSE FLUSHING RADIATOR

Disconnect the radiator hoses from the radiator fittings. Attach a section of radiator hose to the radiator bottom outlet fitting and insert the flushing gun. Connect a water supply hose and air supply hose to the flushing gun.

CAUTION: The cooling system normally operates at 90-to-117 kPa (13- to-17 psi) pressure. Exceeding this pressure may damage the radiator or hoses.

Allow the coolant tank and radiator to fill with water. When radiator is filled, apply air in short blasts allowing radiator to refill between blasts. Continue this reverse flushing until clean water flows out through rear of radiator cooling tube passages. For more information, refer to operating instructions supplied with flushing equipment. Have radiator cleaned more extensively by a radiator repair shop.

REVERSE FLUSHING ENGINE

Drain the cooling system. Remove the thermostat housing and thermostat. Install the thermostat housing. Disconnect the radiator upper hose from the radiator and attach the flushing gun to the hose. Disconnect the radiator lower hose from the water pump. Attach a lead away hose to the water pump inlet fitting.

CAUTION: Be sure that the heater water control valve is closed (heat off). This is done to prevent coolant flow with scale and other deposits from entering the heater core.

Connect the water supply hose and air supply hose to the flushing gun. Allow the engine to fill with water. When the engine is filled, apply air in short blasts, allowing the system to fill between air blasts. Continue until clean water flows through the lead away hose. For more information, refer to operating instructions supplied with flushing equipment.

CLEANING AND INSPECTION (Continued)

Remove the lead away hose, flushing gun, water supply hose and air supply hose. Remove the thermostat housing and install thermostat. Install the thermostat housing with a new replacement rubber seal. Refer to Thermostat Installation. Connect the radiator hoses. Refill the cooling system with the correct antifreeze/water mixture.

CHEMICAL CLEANING

In some instances, use a radiator cleaner (Mopar Radiator Kleen or equivalent) before flushing. This will soften scale and other deposits and aid the flushing operation.

CAUTION: Be sure instructions on the container are followed.

SPECIFICATIONS

COOLING SYSTEM CAPACITY

2.5L Diesel Engine: 9.8 Liters (10.4 qts.)

THERMOSTAT

Starts to open at 80°C (176°F).

TORQUE SPECIFICATIONS

DESCRIPTION	TORQUE
Automatic Belt Tensioner-to-Mounting Bracket Bolt (1)	75 N·m
Automatic Belt Tensioner to Block Bolts (2)	120 N·m
Coolant Tank Cap	5 N·m
Fan Shroud-to-Radiator Mounting Bolts	3 N·m
Fan Blade-to-Thermal Viscous Fan Drive Bolts	23 N·m
Hose Clamps	4 N·m
Radiator-to-A/C Condenser Isolator Nuts	6 N·m
Thermal Viscous Fan Drive-to-Fan Hub Bolts	56 N·m
Thermostat Housing Bolts	11 N·m
Water Pump Mounting Bolts	24 N·m
Water Pump Pulley Bolts	24 N·m