

TURN SIGNAL AND HAZARD WARNING SYSTEMS

TABLE OF CONTENTS

	page		page
DESCRIPTION AND OPERATION		TURN SIGNAL SWITCH AND HAZARD	
TURN SIGNAL SYSTEM.....	1	WARNING SWITCH.....	5
HAZARD WARNING SYSTEM.....	1	REMOVAL AND INSTALLATION	
TURN SIGNAL SWITCH AND HAZARD		COMBINATION FLASHER.....	5
WARNING SWITCH.....	2	TURN SIGNAL SWITCH AND HAZARD	
TURN SIGNAL CANCELLING CAM.....	3	WARNING SWITCH.....	6
COMBINATION FLASHER.....	3		
DIAGNOSIS AND TESTING			
TURN SIGNAL AND HAZARD WARNING			
SYSTEMS.....	4		

DESCRIPTION AND OPERATION

TURN SIGNAL SYSTEM

DESCRIPTION

A turn signal system is standard factory-installed safety equipment on this model. The turn signal system uses ignition switched battery current, and will operate only when the ignition switch is in the On or Accessory positions. The turn signal system includes the following components:

- Combination flasher
- Front side marker lamps
- Turn signal cancelling cam
- Turn signal indicator lamps
- Turn signal lamps
- Turn signal switch.

Refer to **Lamp** in the proper section of Group 8L - Lamps for more information on the exterior turn signal lamps. Refer to **Instrument Cluster** in the proper section of Group 8E - Instrument Panel Systems for more information on the turn signal indicator lamps. Following are general descriptions of the major components in the turn signal system. For complete circuit diagrams, refer to **Turn Signals** in the Contents of Group 8W - Wiring Diagrams.

OPERATION

With the ignition switch in the On or Accessory position, and the turn signal (multi-function) switch control stalk moved up (right turn) or down (left turn), the turn signal system is activated. When the turn signal system is activated, the circuitry of the turn signal switch and the combination flasher will cause the selected (right or left) turn signal indicator lamp, front park/turn signal lamp, front side marker

lamp and rear tail/stop/turn signal lamp to flash on and off. If the exterior lamps are turned off, the front park/turn signal lamp and the front side marker lamp will flash in unison. If the exterior lamps are turned on, the front park/turn signal lamp and the front side marker lamp will flash alternately.

See the owner's manual in the vehicle glove box for more information on the features, use and operation of the turn signal system.

HAZARD WARNING SYSTEM

DESCRIPTION

A hazard warning system is standard factory-installed safety equipment on this model. Unlike the turn signal system, the hazard warning system uses a non-switched source of battery current so that the system will operate regardless of the ignition switch position. The hazard warning system includes the following components:

- Combination flasher
- Front side marker lamps
- Hazard warning switch
- Turn signal indicator lamps
- Turn signal lamps.

Refer to **Lamp** in the proper section of Group 8L - Lamps for more information on the exterior turn signal lamps. Refer to **Instrument Cluster** in the proper section of Group 8E - Instrument Panel Systems for more information on the turn signal indicator lamps. Following are general descriptions of the major components in the hazard warning system. For complete circuit diagrams, refer to **Turn Signals** in the Contents of Group 8W - Wiring Diagrams.

DESCRIPTION AND OPERATION (Continued)

OPERATION

With the hazard warning switch in the On position, the hazard warning system is activated. When the hazard warning system is activated, the circuitry of the hazard warning switch and the combination flasher will cause both the right side and the left side turn signal indicator lamps, front park/turn signal lamps, front side marker lamps and rear tail/stop/turn signal lamps to flash on and off. If the exterior lamps are turned off, the front park/turn signal lamps and the front side marker lamps will flash in unison. If the exterior lamps are turned on, the front park/turn signal lamps and the front side marker lamps will flash alternately.

See the owner's manual in the vehicle glove box for more information on the features, use and operation of the hazard warning system.

TURN SIGNAL SWITCH AND HAZARD WARNING SWITCH

DESCRIPTION

The turn signal and hazard warning switches are integral to the multi-function switch unit, which is secured to the left side of the steering column (Fig. 1). The only visible parts of the multi-function switch are the control stalk that extends from the left side of the steering column, and the hazard warning switch button that protrudes from the top of the steering column. The multi-function switch control stalk has international control symbols on it, which identify its functions. The hazard warning switch button is identified with a double triangle, which is the international control symbol for hazard warning. The remainder of the multi-function switch is concealed beneath the steering column shrouds.

The multi-function switch also contains circuitry for the following functions:

- Headlamp beam selection
- Headlamp optical horn

The information contained in this group addresses only the multi-function switch turn signal and hazard warning functions. For information relative to the other systems that are controlled by and circuits that are integral to the multi-function switch, see the group in this service manual that covers that system. However, the turn signal and hazard warning switches cannot be repaired. If these switches or any other circuit or component of the multi-function switch unit is faulty or damaged, the entire multi-function switch unit must be replaced.

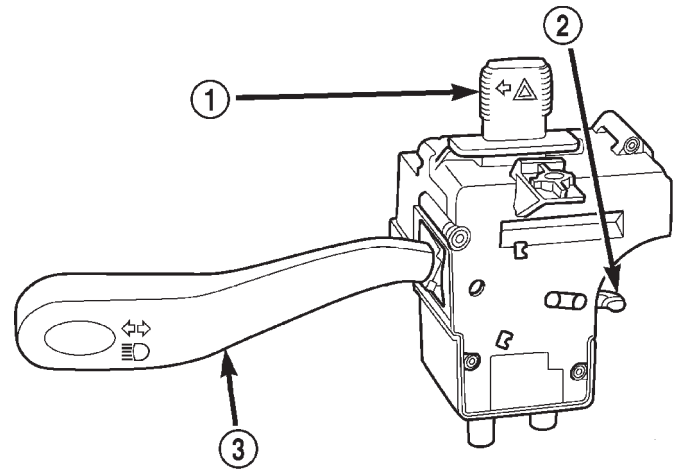

80ad8458

Fig. 1 Multi-Function Switch

- 1 - HAZARD WARNING BUTTON
- 2 - CANCEL ACTUATOR
- 3 - CONTROL STALK

OPERATION

TURN SIGNAL SWITCH

The multi-function switch control stalk that extends from the left side of the steering column just below the steering wheel is moved up or down to activate the turn signal switch. When the control stalk is moved in the upward direction, the right turn signal switch circuitry is activated; and, when the control stalk is moved in the downward direction, the left turn signal switch circuitry is activated. The turn signal switch has a detent position in each direction that provides turn signals with automatic cancellation, and an intermediate momentary position in each direction that provides turn signals only until the multi-function switch control stalk is released.

When the turn signal switch is in a detent position, it is turned off by one of two turn signal cancelling cam lobes that are integral to the rotor of the clockspring mechanism. Turning the steering wheel causes the turn signal cancelling cam lobes to contact a cancel actuator in the multi-function switch, and the turn signal switch automatically returns to the off position.

HAZARD WARNING SWITCH

The hazard warning switch is controlled by the hazard warning switch button. Slide the switch button to the left to turn the switch on and activate the hazard warning system, and slide the button to the right again to turn the switch and the hazard warning system off.

DESCRIPTION AND OPERATION (Continued)

TURN SIGNAL CANCELLING CAM

DESCRIPTION

The turn signal cancelling cam is concealed within the steering column below the steering wheel. The turn signal cancelling cam consists of two lobes that are integral to the lower surface of the clockspring rotor. The clockspring mechanism provides turn signal cancellation as well as a constant electrical connection between the horn switch, driver side airbag module and speed control switches on the steering wheel and the instrument panel wire harness on the steering column. The housing of the clockspring is secured to the steering column and remains stationary. The rotor of the clockspring, including the turn signal cancelling cam lobes rotate with the steering wheel.

The turn signal cancelling cam is integral to the clockspring and cannot be repaired. If faulty or damaged, the entire clockspring assembly must be replaced. Refer to **Clockspring** in the Removal and Installation section of Group 8M - Passive Restraint Systems for the clockspring service procedures.

OPERATION

The turn signal cancelling cam has two lobes molded into the lower surface of the clockspring rotor. When the turn signals are activated by moving the multi-function switch control stalk to a detent position, a turn signal cancel actuator is extended from the inside surface of the multi-function switch housing toward the clockspring rotor. When the steering wheel is rotated during the turn, one of the two turn signal cancelling cam lobes will contact the turn signal cancel actuator, releasing the multi-function switch control stalk from its detent and cancelling the turn signal event.

COMBINATION FLASHER

DESCRIPTION

The combination flasher is a smart relay that functions as both the turn signal system and the hazard warning system flasher. The combination flasher contains active electronic Integrated Circuitry (IC) elements. This flasher is designed to handle the current flow requirements of the factory-installed lighting. If supplemental lighting is added to the turn signal lamp circuits, such as when towing a trailer with lights, the combination flasher will automatically try to compensate to keep the flash rate the same.

While the combination flasher has a International Standards Organization (ISO)-type relay terminal configuration or footprint, the internal circuitry is much different. The combination flasher does not use standard ISO-relay inputs or provide ISO-relay type

outputs or functions. The combination flasher should never be substituted for an ISO-relay or replaced with an ISO-relay, or else component and vehicle damage may occur.

Because of the active electronic elements within the combination flasher, it cannot be tested with conventional automotive electrical test equipment. If the combination flasher is believed to be faulty, test the turn signal system and hazard warning system circuits as described in this group. Then replace the combination flasher with a known good unit to confirm system operation.

The combination flasher has five blade-type terminals intended for the following inputs and outputs: fused B(+), fused ignition switch output, ground, turn signal circuit, and hazard warning circuit. Constant battery voltage and ground are supplied to the flasher so that it can perform the hazard warning function, and ignition switched battery voltage is supplied for the turn signal function. Refer to **Turn Signals** in the Contents of Group 8W - Wiring Diagrams for complete circuit diagrams.

The combination flasher is located in a wire harness connector which is secured to the diagnostics splice block bracket outboard of the steering column opening underneath the instrument panel. The combination flasher cannot be repaired or adjusted and, if faulty or damaged, it must be replaced.

OPERATION

The IC within the combination flasher (Fig. 2) contains the logic that controls the flasher operation and the flash rate. Pin 6 of the IC receives a sense voltage from the hazard warning circuit of the multi-function switch. When the hazard warning switch is turned on, the "hazard on sense" voltage will become low due to the circuit being grounded through the turn signal bulbs. This low voltage sense signals the IC to energize the flash control Positive-Negative-Positive (PNP) transistor at a pre-calibrated flash rate or frequency. Each time the PNP transistor energizes the hazard warning circuit, the pin 6 "hazard on sense" voltage will become high and the IC signals the PNP transistor to de-energize the circuit. This cycling will continue until the hazard warning switch is turned off.

Likewise, pin 8 of the IC receives a sense voltage from the turn signal circuits of the multi-function switch. When the left or right turn signal switch is turned on, the "turn signal on sense" voltage will become low due to the circuit being grounded through the turn signal bulbs. This low voltage sense signals the IC to energize the flash control PNP transistor at a pre-calibrated flash rate or frequency. Each time the PNP transistor energizes the turn signal circuit, the pin 8 "turn signal on sense" voltage

DESCRIPTION AND OPERATION (Continued)

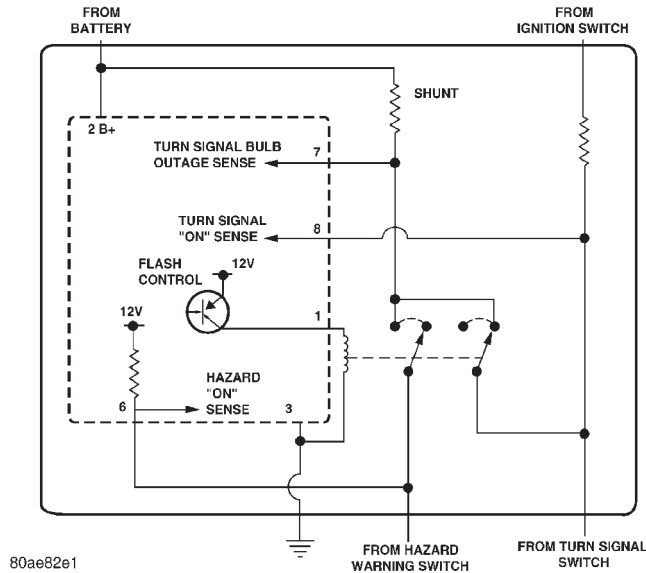

Fig. 2 Combination Flasher - Typical

will become high and the IC signals the PNP transistor to de-energize the circuit. This cycling will continue until the right or left turn signal switch is turned off.

A special design feature of the combination flasher allows it to “sense” that a turn signal circuit or bulb is not operating, and provide the driver an indication of the condition by flashing the remaining bulbs in the affected circuit at a higher rate (120 flashes-per-minute or higher). Conventional flashers either continue flashing at their typical rate (heavy-duty type), or discontinue flashing the affected circuit entirely (standard-duty type). During turn signal operation, the combination flasher IC compares normal battery voltage input on pin 2 with the shunt resistor voltage input on pin 7. If the IC “senses” that the voltage difference between pin 2 and pin 7 is different than the pre-calibrated value of the IC, it will increase the rate at which it signals the PNP transistor to energize the pin 1 output. Thus, the inoperative half (left or right side) of the turn signal circuit will flash faster.

DIAGNOSIS AND TESTING

TURN SIGNAL AND HAZARD WARNING SYSTEMS

When diagnosing the turn signal or hazard warning circuits, remember that high generator output can burn out bulbs rapidly and repeatedly. If this is a problem on the vehicle being diagnosed, refer to **Charging System** in the Diagnosis and Testing section of Group 8C - Charging System for further diagnosis of a possible generator overcharging condition.

If the problem being diagnosed is related to a failure of the turn signals to automatically cancel following completion of a turn, inspect the multi-function switch for a faulty or damaged cancel actuator and inspect the turn signal cancelling cam lobes on the clockspring mechanism for damage or improper installation. For complete circuit diagrams, refer to **Turn Signals** in the Contents of Group 8W - Wiring Diagrams.

WARNING: ON VEHICLES EQUIPPED WITH AIR-BAGS, REFER TO GROUP 8M - PASSIVE RESTRAINT SYSTEMS BEFORE ATTEMPTING ANY STEERING WHEEL, STEERING COLUMN, OR INSTRUMENT PANEL COMPONENT DIAGNOSIS OR SERVICE. FAILURE TO TAKE THE PROPER PRECAUTIONS COULD RESULT IN ACCIDENTAL AIR-BAG DEPLOYMENT AND POSSIBLE PERSONAL INJURY.

(1) Turn the ignition switch to the On position. Actuate the turn signal switch or the hazard warning switch. Observe the turn signal indicator lamp(s) in the instrument cluster. If the flash rate is very high, check for a turn signal bulb that is not lit or is very dimly lit. Repair the circuits to that lamp or replace the faulty bulb, as required. If the turn signal indicator(s) fail to light, go to Step 2.

(2) Turn the ignition switch to the Off position. Check the turn signal fuse in the junction block and/or the hazard warning fuse in the Power Distribution Center (PDC). If OK, go to Step 3. If not OK, repair the shorted circuit or component as required and replace the faulty fuse(s).

(3) Check for battery voltage at the hazard warning fuse in the PDC. If OK, go to Step 4. If not OK, repair the open fused B(+) circuit to the battery as required.

(4) Turn the ignition switch to the On position. Check for battery voltage at the turn signal fuse in the fuseblock module. If OK, go to Step 5. If not OK, repair the open fused ignition switch output (accessory/run) circuit to the ignition switch as required.

(5) Turn the ignition switch to the Off position. Disconnect and isolate the battery negative cable. Remove the combination flasher from its wire harness connector and replace it with a known good unit. Connect the battery negative cable. Test the operation of the turn signal and hazard warning systems. If OK, discard the faulty combination flasher. If not OK, remove the test flasher and go to Step 6.

(6) Turn the ignition switch to the On position. Check for battery voltage at the fused ignition switch output (accessory/run) circuit cavity in the combination flasher wire harness connector. If OK, go to Step 7. If not OK, go to Step 9.

DIAGNOSIS AND TESTING (Continued)

(7) Turn the ignition switch to the Off position. Place the hazard warning switch in the On position. Check for battery voltage again at the fused B+ circuit cavity in the combination flasher wire harness connector. If OK, go to Step 8. If not OK, go to Step 9.

(8) Disconnect and isolate the battery negative cable. Check for continuity between the ground circuit cavity of the combination flasher wire harness connector and a good ground. There should be continuity. If OK, go to Step 9. If not OK, repair the open ground circuit to ground as required.

(9) Disconnect the instrument panel wire harness connector from the multi-function switch connector receptacle. Check for continuity between the turn signal output circuit cavities in the combination flasher wire harness connector and in the instrument panel wire harness connector for the multi-function switch. There should be continuity. If OK, go to Step 10. If not OK, repair the open turn signal output circuit as required.

(10) Check for continuity between the hazard warning output circuit cavities in the combination flasher wire harness connector and in the instrument panel wire harness connector for the multi-function switch. There should be continuity. If OK, refer to **Turn Signal Switch and Hazard Warning Switch** in the Diagnosis and Testing section of this group. If not OK, repair the open hazard warning output circuit as required.

TURN SIGNAL SWITCH AND HAZARD WARNING SWITCH

The turn signal switch and the hazard warning switch are integral to the multi-function switch. Refer to **Turn Signal and Hazard Warning Systems** in the Diagnosis and Testing section of this group before testing the multi-function switch. For complete circuit diagrams, refer to **Turn Signals** in the Contents of Group 8W - Wiring Diagrams.

WARNING: ON VEHICLES EQUIPPED WITH AIRBAGS, REFER TO GROUP 8M - PASSIVE RESTRAINT SYSTEMS BEFORE ATTEMPTING ANY STEERING WHEEL, STEERING COLUMN, OR INSTRUMENT PANEL COMPONENT DIAGNOSIS OR SERVICE. FAILURE TO TAKE THE PROPER PRECAUTIONS COULD RESULT IN ACCIDENTAL AIRBAG DEPLOYMENT AND POSSIBLE PERSONAL INJURY.

(1) Disconnect and isolate the battery negative cable. Disconnect the instrument panel wire harness connector from the multi-function switch connector receptacle.

(2) Using an ohmmeter, perform the switch continuity checks at the connector receptacle terminals as

shown in the Multi-Function Switch Continuity chart (Fig. 3).

SWITCH POSITION		CONTINUITY BETWEEN
TURN SIGNAL	HAZARD WARNING	
NEUTRAL	OFF	F and H F and K A and E
LEFT	OFF	F and H C and K C and I A and E
RIGHT	OFF	F and K C and H C and J A and E
NEUTRAL	ON	B and E C and H C and K C and I C and J

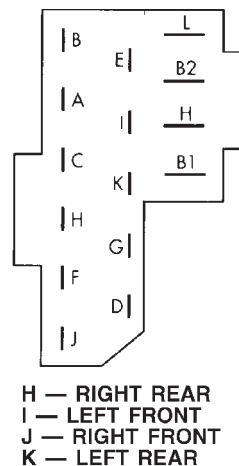

948J-12

Fig. 3 Multi-Function Switch Continuity

(3) If the turn signal switch or hazard warning switch fails any of the continuity checks, replace the faulty multi-function switch assembly as required. If the switch circuits are OK, repair the lighting circuits as required.

REMOVAL AND INSTALLATION

COMBINATION FLASHER

WARNING: ON VEHICLES EQUIPPED WITH AIRBAGS, REFER TO GROUP 8M - PASSIVE RESTRAINT SYSTEMS BEFORE ATTEMPTING ANY STEERING WHEEL, STEERING COLUMN, OR INSTRUMENT PANEL COMPONENT DIAGNOSIS OR SERVICE. FAILURE TO TAKE THE PROPER PRECAUTIONS COULD RESULT IN ACCIDENTAL AIRBAG DEPLOYMENT AND POSSIBLE PERSONAL INJURY.

REMOVAL

(1) Disconnect and isolate the battery negative cable.

(2) Remove the knee blocker from the instrument panel. Refer to **Knee Blocker** in the Removal and Installation section of Group 8E - Instrument Panel Systems for the procedures.

(3) Reach through the outboard side of the steering column opening to access and disengage the combination flasher wire harness connector retainer from

REMOVAL AND INSTALLATION (Continued)

the instrument panel diagnostics mounting bracket (Fig. 4).

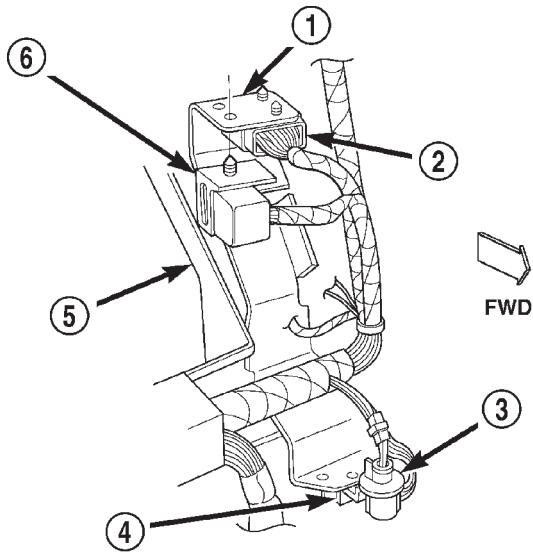

80b099c9

Fig. 4 Combination Flasher Remove/Install

- 1 - DIAGNOSTICS MOUNTING BRACKET
- 2 - DIAGNOSTICS SPLICE BLOCK
- 3 - INSTRUMENT PANEL COURTESY LAMP
- 4 - DATA LINK CONNECTOR
- 5 - OUTBOARD STEERING COLUMN OPENING
- 6 - COMBINATION FLASHER AND CONNECTOR

(4) Pull the combination flasher into the instrument panel steering column opening far enough to access the wire harness connector.

(5) Remove the combination flasher from the wire harness connector.

(6) Remove the combination flasher from under the instrument panel.

INSTALLATION

(1) Position the combination flasher under the instrument panel.

(2) Align the combination flasher terminals with the terminal cavities in the wire harness connector.

(3) Push in firmly on the combination flasher until the terminals are fully seated in the terminal cavities in the wire harness connector.

(4) Install the combination flasher wire harness connector retainer into the mounting hole of the instrument panel diagnostics mounting bracket.

(5) Install the knee blocker onto the instrument panel. Refer to **Knee Blocker** in the Removal and Installation section of Group 8E - Instrument Panel Systems for the procedures.

(6) Reconnect the battery negative cable.

TURN SIGNAL SWITCH AND HAZARD WARNING SWITCH

WARNING: ON VEHICLES EQUIPPED WITH AIRBAGS, REFER TO GROUP 8M - PASSIVE RESTRAINT SYSTEMS BEFORE ATTEMPTING ANY STEERING WHEEL, STEERING COLUMN, OR INSTRUMENT PANEL COMPONENT DIAGNOSIS OR SERVICE. FAILURE TO TAKE THE PROPER PRECAUTIONS COULD RESULT IN ACCIDENTAL AIRBAG DEPLOYMENT AND POSSIBLE PERSONAL INJURY.

REMOVAL

(1) Disconnect and isolate the battery negative cable.

(2) Remove the knee blocker from the instrument panel. Refer to **Knee Blocker** in the Removal and Installation section of Group 8E - Instrument Panel Systems for the procedures.

(3) Remove the three screws that secure the lower steering column shroud to the upper shroud (Fig. 5).

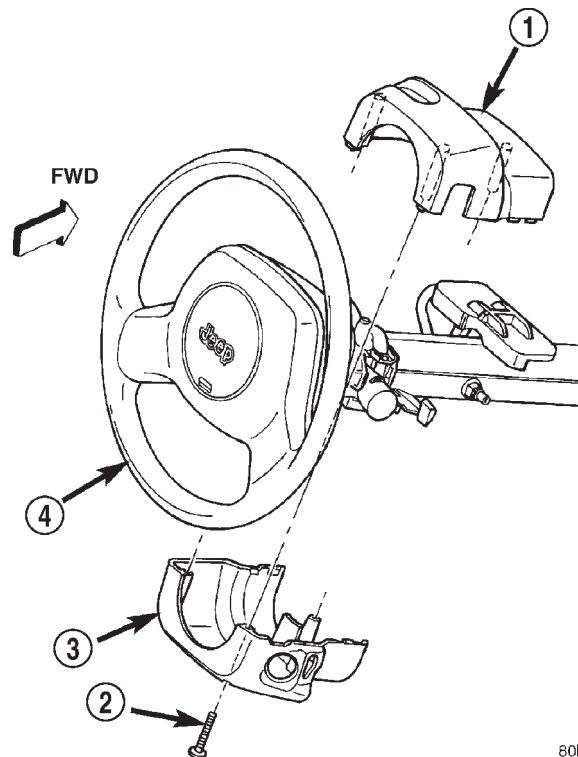

80b76efa

Fig. 5 Steering Column Shrouds Remove/Install

- 1 - UPPER SHROUD
- 2 - SCREW (3)
- 3 - LOWER SHROUD
- 4 - STEERING WHEEL

(4) If the vehicle is equipped with a standard non-tilt steering column, loosen the two upper steering column mounting nuts. If the vehicle is equipped

REMOVAL AND INSTALLATION (Continued)

with the optional tilt steering column, move the tilt steering column to the fully lowered position.

(5) Remove both the upper and lower shrouds from the steering column.

(6) Remove the two screws that secure the multi-function switch water shield and bracket to the top of the steering column (Fig. 6).

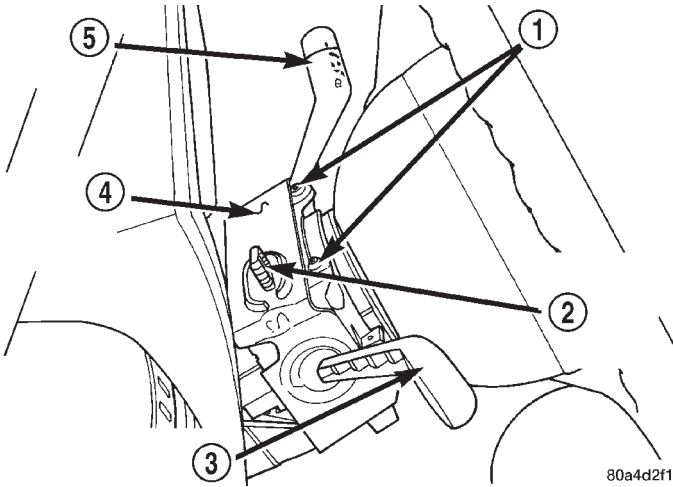

80a4d2f1

Fig. 6 Water Shield Upper Screws Remove/Install

- 1 - MOUNTING SCREWS
- 2 - HAZARD WARNING SWITCH KNOB
- 3 - MULTI-FUNCTION SWITCH LEVER
- 4 - WATER SHIELD AND BRACKET
- 5 - WIPER SWITCH LEVER

(7) Remove the one screw located below the multi-function switch control stalk that secures the multi-function switch water shield and bracket to the steering column (Fig. 7).

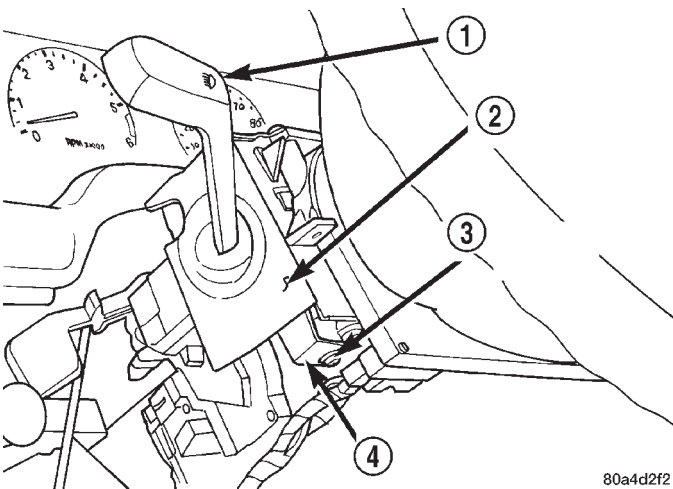

80a4d2f2

Fig. 7 Water Shield Lower Screw Remove/Install

- 1 - MULTI-FUNCTION SWITCH LEVER
- 2 - WATER SHIELD AND BRACKET
- 3 - LOWER MOUNTING SCREW
- 4 - LOWER MOUNTING TAB

(8) Gently pull the lower mounting tab of the multi-function switch water shield bracket away from the steering column far enough to clear the screw boss below the multi-function switch control stalk.

(9) Lift the water shield and bracket with the multi-function switch off of the left side of the steering column far enough to access the two multi-function switch wire harness connectors. If the vehicle is equipped with the optional tilt steering column, lifting gently upward on the tilt release lever will provide additional clearance to ease multi-function switch removal.

(10) Disconnect the two instrument panel wire harness connectors from the multi-function switch connector receptacles.

(11) Remove the multi-function switch and water shield from the steering column as a unit.

(12) Gently and carefully remove the water shield from the switch by pulling it over the hazard warning switch button and the multi-function switch control stalk.

INSTALLATION

(1) Gently and carefully install the water shield onto the switch by pulling it over the hazard warning switch button and the multi-function switch control stalk.

(2) Position the multi-function switch and water shield near its mounts on the steering column as a unit.

(3) Reconnect the two instrument panel wire harness connectors to the multi-function switch connector receptacles.

(4) Position the multi-function switch onto its mounts on the left side of the steering column. If the vehicle is equipped with the optional tilt steering column, lifting gently upward on the tilt release lever will provide additional clearance to ease multi-function switch installation.

(5) Position the lower mounting tab of the multi-function switch water shield bracket to the steering column screw boss below the multi-function switch control stalk.

(6) Install and tighten the one screw located below the multi-function switch control stalk that secures the multi-function switch water shield and bracket to the steering column. Tighten the screw to 1.1 N·m (10 in. lbs.).

(7) Install and tighten the two screws that secure the multi-function switch water shield and bracket to the top of the steering column. Tighten the screws to 2.2 N·m (20 in. lbs.).

(8) Position both the upper and lower shrouds onto the steering column.

REMOVAL AND INSTALLATION (Continued)

(9) Install and tighten the three screws that secure the lower steering column shroud to the upper shroud. Tighten the screws to 2 N·m (18 in. lbs.).

(10) If the vehicle is so equipped, tighten the two nuts that secure the non-tilt steering column upper mounting bracket to the dash panel steering column support bracket studs. Tighten the nuts to 22 N·m (200 in. lbs.).

(11) Install the knee blocker onto the instrument panel. Refer to **Knee Blocker** in the Removal and Installation section of Group 8E - Instrument Panel Systems for the procedures.

(12) Reconnect the battery negative cable.