

# ELECTRICALLY HEATED SYSTEMS

## TABLE OF CONTENTS

	page		page
REAR WINDOW DEFOGGER SYSTEM . . . . .	1	HEATED SEAT SYSTEM . . . . .	8

# REAR WINDOW DEFOGGER SYSTEM

## TABLE OF CONTENTS

	page		page
<b>GENERAL INFORMATION</b>			
INTRODUCTION . . . . .	1	REAR GLASS HEATING GRID . . . . .	4
REAR WINDOW DEFOGGER SYSTEM . . . . .	1	DEFOGGER SWITCH . . . . .	4
<b>DESCRIPTION AND OPERATION</b>			
REAR GLASS HEATING GRID . . . . .	2	DEFOGGER RELAY . . . . .	4
OUTSIDE MIRROR HEATING GRID . . . . .	2	INSTRUMENT CLUSTER . . . . .	5
DEFOGGER SWITCH . . . . .	2	<b>SERVICE PROCEDURES</b>	
INSTRUMENT CLUSTER . . . . .	2	REAR GLASS HEATING GRID REPAIR . . . . .	6
DEFOGGER RELAY . . . . .	3	<b>REMOVAL AND INSTALLATION</b>	
<b>DIAGNOSIS AND TESTING</b>			
DEFOGGER SYSTEM . . . . .	3	DEFOGGER SWITCH . . . . .	6
		DEFOGGER RELAY . . . . .	7

## GENERAL INFORMATION

### INTRODUCTION

An electrically heated rear window defogger and electrically heated outside rear view mirrors are available factory-installed options on this model. Refer to 8W-48 - Rear Window Defogger and 8W-62 - Power Mirrors in Group 8W - Wiring Diagrams for complete circuit descriptions and diagrams.

**NOTE:** This group covers both Left-Hand Drive (LHD) and Right-Hand Drive (RHD) versions of this model. Whenever required and feasible, the RHD versions of affected vehicle components have been constructed as mirror-image of the LHD versions. While most of the illustrations used in this group represent only the LHD version, the diagnostic and service procedures outlined can generally be applied to either version. Exceptions to this rule have been clearly identified as LHD or RHD, if a special illustration or procedure is required.

## REAR WINDOW DEFOGGER SYSTEM

The rear window defogger system will only operate when the ignition switch is in the On position. When the defogger switch is in the On position, an electric heater grid on the rear window glass is energized. Vehicles with the heated mirror options also have heater grids located behind the outside rear view mirror glass. Each of these grids produce heat to help clear the rear window glass and outside rear view mirrors of ice, snow, or fog.

The defogger system is controlled by a switch installed in the instrument panel accessory switch bezel, which is located near the bottom of the instrument panel center bezel area, below the heater and air conditioner controls. An amber indicator lamp in the switch button will light to indicate when the defogger system is turned on. The instrument cluster circuitry, which contains the defogger system timer logic, monitors the state of the defogger switch through a hard-wired input. The instrument cluster circuitry controls the defogger system through a hard-wired control output to the defogger relay.

The defogger system will be automatically turned off after a programmed time interval of about ten minutes. After the initial time interval has expired, if

## GENERAL INFORMATION (Continued)

the defogger switch is turned on again during the same ignition cycle, the defogger system will automatically turn off after about five minutes.

The defogger system will automatically shut off if the ignition switch is turned to the Off position, or it can be turned off manually by depressing the instrument panel switch. Following are general descriptions of the major components in the defogger system. Refer to the owner's manual in the vehicle glove box for more information on the features, use and operation of the defogger system.

## DESCRIPTION AND OPERATION

## REAR GLASS HEATING GRID

The heated rear window glass has two electrically conductive vertical bus bars and a series of horizontal grid lines made of a silver-ceramic material, which is baked on and bonded to the inside surface of the glass. The grid lines and bus bars comprise a parallel electrical circuit.

When the rear window defogger switch is placed in the On position, electrical current is directed to the rear window grid lines through the bus bars. The grid lines heat the rear window to clear the surface of fog or snow. Protection for the heated grid circuit is provided by a fuse in the Power Distribution Center (PDC).

The grid lines and bus bars are highly resistant to abrasion. However, it is possible for an open circuit to occur in an individual grid line, resulting in no current flow through the line.

The grid lines can be damaged or scraped off with sharp instruments. Care should be taken when cleaning the glass or removing foreign materials, decals, or stickers from the glass. Normal glass cleaning solvents or hot water used with rags or toweling is recommended.

A repair kit is available to repair the grid lines and bus bars, or to reinstall the heated glass pigtail wires.

## OUTSIDE MIRROR HEATING GRID

Vehicles equipped with the optional heated mirror package have an electric heating grid located behind the mirror glass of each outside rear view mirror. The heated mirrors are controlled by the rear window defogger switch. Electrical current is directed to the heating grid inside the mirror only when the rear window defogger switch is in the On position.

If the outside mirror heating grids and the rear window heating grid are all inoperative, diagnosis of the rear window defogger system should be performed as described in this group. If the outside mirror heating grids are inoperative, but the rear

window heating grid is operating as designed, refer to Power Mirror in the Diagnosis and Testing section of Group 8T - Power Mirror Systems for diagnosis of the mirror heating grids.

The heating grid behind each outside mirror glass cannot be repaired and, if faulty or damaged, the entire power mirror unit must be replaced. Refer to Power Mirror in the Removal and Installation section of Group 8T - Power Mirror Systems for the service procedures.

## DEFOGGER SWITCH

The rear window defogger switch is installed in the instrument panel accessory switch bezel, which is located near the bottom of the instrument panel center bezel area, below the heater and air conditioner controls. The momentary-type switch provides a hard-wired ground signal to the instrument cluster each time it is depressed. The instrument cluster rear window defogger timer and logic circuitry responds by energizing or de-energizing the rear window defogger relay.

Energizing the rear window defogger relay provides electrical current to the rear window defogger grid and, if the vehicle is so equipped, the outside rear view mirror heating grids. An amber indicator lamp in the defogger switch, which lights to indicate when the defogger system is turned On, is also powered by the defogger relay output.

The defogger switch illumination lamp and indicator lamp bulbs are serviceable. The defogger switch cannot be repaired and, if faulty or damaged, it must be replaced.

## INSTRUMENT CLUSTER

The instrument cluster is an electromechanical unit that contains integrated circuitry and internal programming to perform a variety of functions. The instrument cluster circuitry monitors hard-wired switch inputs, as well as message inputs received from other vehicle electronic control modules on the Chrysler Collision Detection (CCD) data bus network.

The instrument cluster uses these many inputs along with its internal programming and integral timer and logic circuitry to perform the functions of the rear window defogger timer on this model. The instrument cluster circuitry also has a self-diagnostic capability. Refer to Instrument Cluster in Group 8E - Instrument Panel Systems for more information on this feature.

However, there are no diagnostics available for the rear window defogger timer and logic circuitry. Therefore, the diagnosis for this system consists of confirming the presence of a rear window defogger switch input signal at the instrument cluster connector, and the resulting rear window defogger relay

## DESCRIPTION AND OPERATION (Continued)

control output signal at the defogger relay. For diagnosis of the CCD data bus and the data bus message inputs, a DRB scan tool and the proper Diagnostic Procedures manual are recommended.

Refer to Instrument Cluster in Group 8E - Instrument Panel Systems for the service procedures for the instrument cluster. The rear window defogger timer and logic circuitry cannot be adjusted or repaired and, if faulty or damaged, the instrument cluster assembly must be replaced.

## DEFOGGER RELAY

The rear window defogger relay is a International Standards Organization (ISO)-type relay. The rear window defogger relay is a electromechanical device that switches fused battery current to the rear glass and outside mirror heating grids, and the indicator lamp of the defogger switch, when the instrument cluster rear window defogger timer and logic circuitry grounds the relay coil. See Defogger Relay in the Diagnosis and Testing section of this group for more information.

The rear window defogger relay is located in the junction block, on the right cowl side inner panel below the instrument panel in the passenger compartment. The rear window defogger relay cannot be repaired and, if faulty or damaged, it must be replaced.

## DIAGNOSIS AND TESTING

## DEFOGGER SYSTEM

For circuit descriptions and diagrams, refer to 8W-48 - Rear Window Defogger or 8W-62 Power Mirrors in Group 8W - Wiring Diagrams. The operation of the electrically heated rear window defogger system can be confirmed in one of the following manners:

1. Turn the ignition switch to the On position. While monitoring the instrument panel voltmeter, set the defogger switch in the On position. When the defogger switch is turned On, a distinct voltmeter needle deflection should be noted.

2. Turn the ignition switch to the On position. Set the defogger switch in the On position. The rear window defogger operation can be checked by feeling the rear window or outside rear view mirror glass. A distinct difference in temperature between the grid lines and the adjacent clear glass or the mirror glass can be detected within three to four minutes of operation.

3. Using a 12-volt DC voltmeter, contact the rear glass heating grid terminal A (right side) with the negative lead, and terminal B (left side) with the positive lead (Fig. 1). The voltmeter should read battery voltage.

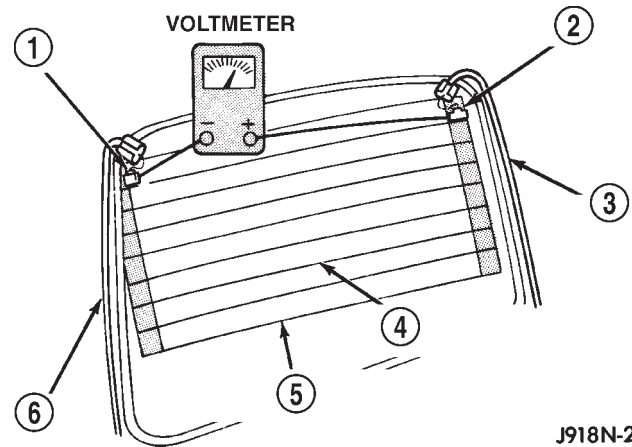

J918N-2

**Fig. 1 Rear Window Glass Grid Test**

- 1 - TERMINAL "A"
- 2 - TERMINAL "B"
- 3 - FEED WIRE
- 4 - MID-POINT "C" (TYPICAL)
- 5 - HEATED REAR WINDOW DEFOGGER GRID
- 6 - GROUND WIRE

The above checks will confirm system operation. Illumination of the defogger switch indicator lamp means that there is electrical current available at the output of the defogger relay, but does not confirm that the electrical current is reaching the rear glass heating grid lines.

If the defogger system does not operate, the problem should be isolated in the following manner:

(1) Confirm that the ignition switch is in the On position.

(2) Ensure that the rear glass heating grid feed and ground wires are connected to the glass. Confirm that the ground wire has continuity to ground.

(3) Check the fuses in the Power Distribution Center (PDC) and in the junction block. The fuses must be tight in their receptacles and all electrical connections must be secure.

When the above steps have been completed and the rear glass or outside rear view mirror heating grid is still inoperative, one or more of the following is faulty:

- Defogger switch
- Defogger relay
- Instrument cluster circuitry
- Rear window grid lines (all grid lines would have to be broken or one of the feed wires disconnected for the entire system to be inoperative)
- Outside rear view mirror heating grid.

If setting the defogger switch to the On position produces a severe voltmeter deflection, check for a short circuit between the defogger relay output and the rear glass or outside rear view mirror heating grids.

DIAGNOSIS AND TESTING (Continued)

**REAR GLASS HEATING GRID**

For circuit descriptions and diagrams, refer to 8W-48 - Rear Window Defogger in Group 8W - Wiring Diagrams. To detect breaks in the grid lines, the following procedure is required:

(1) Turn the ignition switch to the On position. Set the defogger switch in the On position. The indicator lamp should light. If OK, go to Step 2. If not OK, see the Defogger Relay diagnosis in this group.

(2) Using a 12-volt DC voltmeter, contact the vertical bus bar on the right side of the vehicle with the negative lead. With the positive lead, contact the vertical bus bar on the left side of the vehicle. The voltmeter should read battery voltage. If OK, go to Step 3. If not OK, repair the open circuit to the defogger relay as required.

(3) With the negative lead of the voltmeter, contact a good body ground point. The voltage reading should not change. If OK, go to Step 4. If not OK, repair the circuit to ground as required.

(4) Connect the negative lead of the voltmeter to the right side bus bar and touch each grid line at midpoint C with the positive lead. A reading of approximately six volts indicates a line is good. A reading of zero volts indicates a break in the grid line between midpoint C and the left side bus bar. A reading of ten to fourteen volts indicates a break between midpoint C and the right side bus bar. Move the positive lead on the grid line towards the break and the voltage reading will change as soon as the break is crossed.

**DEFOGGER SWITCH**

For circuit descriptions and diagrams, refer to 8W-48 - Rear Window Defogger in Group 8W - Wiring Diagrams.

**WARNING: ON VEHICLES EQUIPPED WITH AIRBAGS, REFER TO GROUP 8M - PASSIVE RESTRAINT SYSTEMS BEFORE ATTEMPTING ANY STEERING WHEEL, STEERING COLUMN, OR INSTRUMENT PANEL COMPONENT DIAGNOSIS OR SERVICE. FAILURE TO TAKE THE PROPER PRECAUTIONS COULD RESULT IN ACCIDENTAL AIRBAG DEPLOYMENT AND POSSIBLE PERSONAL INJURY.**

(1) Disconnect and isolate the battery negative cable. Remove the accessory switch bezel from the instrument panel and unplug the defogger switch wire harness connector.

(2) Check for continuity between the ground circuit cavity of the defogger switch wire harness connector and a good ground. There should be continuity. If OK, go to Step 3. If not OK, repair the open circuit as required.

(3) Check for continuity between the ground circuit terminal and the rear window defogger switch sense circuit terminal on the back of the defogger switch housing (Fig. 2). There should be momentary continuity as the defogger switch button is depressed, and then no continuity. If OK, see the diagnosis for the Instrument Cluster in this group. If not OK, replace the faulty switch.

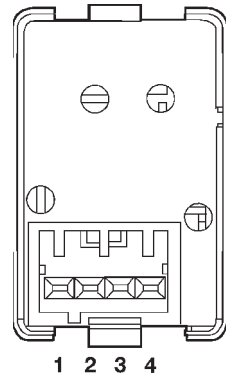

SWITCH POSITION	CONTINUITY BETWEEN
OFF	LAMPS
ON	MOMENTARY 1 AND 2
ILLUMINATION LAMP	1 AND 4
INDICATOR LAMP	1 AND 3

80a5035f

*Fig. 2 Defogger Switch Continuity*

**DEFOGGER RELAY**

**WARNING: ON VEHICLES EQUIPPED WITH AIRBAGS, REFER TO GROUP 8M - PASSIVE RESTRAINT SYSTEMS BEFORE ATTEMPTING ANY STEERING WHEEL, STEERING COLUMN, OR INSTRUMENT PANEL COMPONENT DIAGNOSIS OR SERVICE. FAILURE TO TAKE THE PROPER PRECAUTIONS COULD RESULT IN ACCIDENTAL AIRBAG DEPLOYMENT AND POSSIBLE PERSONAL INJURY.**

**RELAY TEST**

The defogger relay (Fig. 3) is located in the junction block, on the right cowl side inner panel below the instrument panel in the passenger compartment. Remove the defogger relay from the junction block to perform the following tests:

(1) A relay in the de-energized position should have continuity between terminals 87A and 30, and no continuity between terminals 87 and 30. If OK, go to Step 2. If not OK, replace the faulty relay.

(2) Resistance between terminals 85 and 86 (electromagnet) should be  $75 \pm 10$  ohms. If OK, go to Step 3. If not OK, replace the faulty relay.

DIAGNOSIS AND TESTING (Continued)

(3) Connect a battery to terminals 85 and 86. There should now be continuity between terminals 30 and 87, and no continuity between terminals 87A and 30. If OK, see the Relay Circuit Test in this group. If not OK, replace the faulty relay.

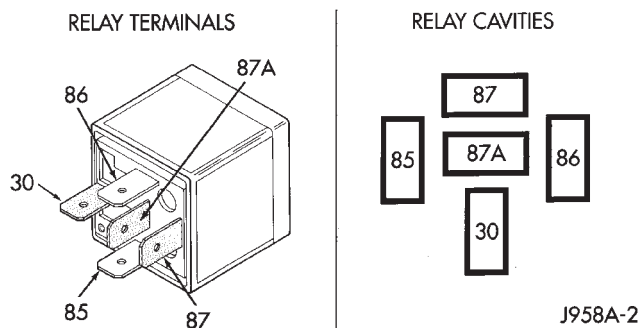

TERMINAL LEGEND	
NUMBER	IDENTIFICATION
30	COMMON FEED
85	COIL GROUND
86	COIL BATTERY
87	NORMALLY OPEN
87A	NORMALLY CLOSED

Fig. 3 Defogger Relay

RELAY CIRCUIT TEST

(1) The relay common feed terminal cavity (30) is connected to battery voltage and should be hot at all times. If OK, go to Step 2. If not OK, repair the open circuit to the PDC fuse as required.

(2) The relay normally closed terminal (87A) is connected to terminal 30 in the de-energized position, but is not used for this application. Go to Step 3.

(3) The relay normally open terminal (87) is connected to the common feed terminal (30) in the energized position. This terminal supplies battery voltage to the rear glass and outside rear view mirror heating grids and the defogger switch indicator lamp. There should be continuity between the cavity for relay terminal 87 and the rear window defogger relay output circuit cavities of the rear glass heating grid connector, both outside rear view mirror heating grid connectors, and the defogger switch connector at all times. If OK, go to Step 4. If not OK, repair the open circuit(s) as required.

(4) The coil ground terminal (85) is connected to the electromagnet in the relay. This terminal is provided with ground by the instrument cluster rear window defogger timer and logic circuitry to energize the defogger relay. There should be continuity to ground at the cavity for relay terminal 85 when the defogger switch is turned On. However, with the defogger relay removed, the defogger switch indicator lamp will not light to show that the defogger system

is turned On. Be certain that you depress the defogger switch at least twice to confirm that the system is turned on during this test. If OK, go to Step 5. If not OK, repair the open circuit to the instrument cluster as required.

(5) The coil battery terminal (86) is connected to the electromagnet in the relay. It is connected to fused ignition switch output voltage and should be hot when the ignition switch is in the On position. Check for battery voltage at the cavity for relay terminal 86 with the ignition switch in the On position. If OK, see the diagnosis for Instrument Cluster in this group. If not OK, repair the open circuit to the fuse in the junction block as required.

INSTRUMENT CLUSTER

Before performing this test, complete the Defogger Switch and the Defogger Relay tests as described in this group. For circuit descriptions and diagrams, refer to 8W-48 - Rear Window Defogger in Group 8W - Wiring Diagrams.

**WARNING: ON VEHICLES EQUIPPED WITH AIR-BAGS, REFER TO GROUP 8M - PASSIVE RESTRAINT SYSTEMS BEFORE ATTEMPTING ANY STEERING WHEEL, STEERING COLUMN, OR INSTRUMENT PANEL COMPONENT DIAGNOSIS OR SERVICE. FAILURE TO TAKE THE PROPER PRECAUTIONS COULD RESULT IN ACCIDENTAL AIR-BAG DEPLOYMENT AND POSSIBLE PERSONAL INJURY.**

(1) Disconnect and isolate the battery negative cable. Remove the defogger relay from the junction block and unplug the defogger switch wire harness connector.

(2) Remove the instrument cluster from the instrument panel. Refer to Instrument Cluster in Group 8E - Instrument Panel Systems for the procedures.

(3) Check for continuity between the rear window defogger switch sense circuit cavity of the right instrument cluster wire harness connector (connector B) and a good ground. There should be no continuity. If OK, go to Step 4. If not OK, repair the short circuit as required.

(4) Check for continuity between the rear window defogger switch sense circuit cavities of the right instrument cluster wire harness connector (connector B) and the defogger switch wire harness connector. There should be continuity. If OK, go to Step 5. If not OK, repair the open circuit as required.

(5) Check for continuity between the rear window defogger relay control circuit cavity of the right instrument cluster wire harness connector (connector B) and a good ground. There should be no continuity. If OK, go to Step 6. If not OK, repair the short circuit as required.

## DIAGNOSIS AND TESTING (Continued)

(6) Check for continuity between the rear window defogger relay control circuit cavities of the right instrument cluster wire harness connector (connector B) and the defogger relay receptacle (the cavity for ISO relay terminal 85) in the junction block. There should be continuity. If OK, replace the faulty instrument cluster. If not OK, repair the open circuit as required.

## SERVICE PROCEDURES

## REAR GLASS HEATING GRID REPAIR

Repair of the rear glass heating grid lines, bus bars, terminals or pigtail wires can be accomplished using a Mopar Rear Window Defogger Repair Kit (Part Number 4267922) or equivalent.

**WARNING: MATERIALS CONTAINED IN THE REPAIR KIT MAY CAUSE SKIN OR EYE IRRITATION. THE KIT CONTAINS EPOXY RESIN AND AMINE TYPE HARDENER, WHICH ARE HARMFUL IF SWALLOWED. AVOID CONTACT WITH THE SKIN AND EYES. FOR SKIN CONTACT, WASH THE AFFECTED AREAS WITH SOAP AND WATER. FOR CONTACT WITH THE EYES, FLUSH WITH PLENTY OF WATER. DO NOT TAKE INTERNALLY. IF TAKEN INTERNALLY, INDUCE VOMITING AND CALL A PHYSICIAN IMMEDIATELY. USE WITH ADEQUATE VENTILATION. DO NOT USE NEAR FIRE OR FLAME. CONTAINS FLAMMABLE SOLVENTS. KEEP OUT OF THE REACH OF CHILDREN.**

(1) Mask the repair area so that the conductive epoxy can be applied neatly. Extend the epoxy application onto the grid line or the bus bar on each side of the break (Fig. 4).

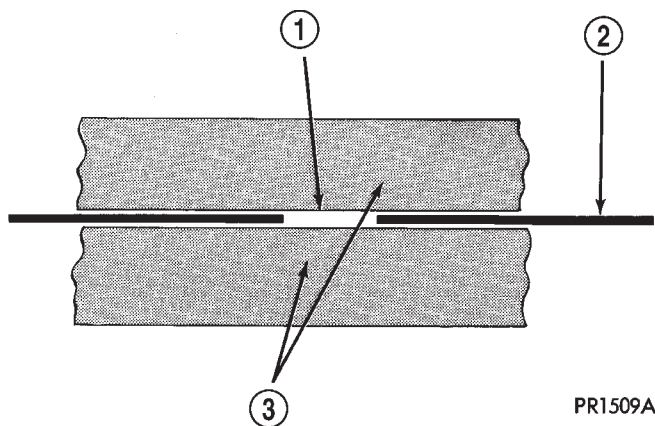

PR1509A

**Fig. 4 Grid Line Repair - Typical**

- 1 - BREAK
- 2 - GRID LINE
- 3 - MASKING TAPE

(2) Follow the instructions in the repair kit for preparing the damaged area.

(3) Remove the package separator clamp and mix the two conductive epoxy components thoroughly within the packaging. Fold the package in half and cut the center corner to dispense the epoxy.

(4) For grid line repairs, mask the area to be repaired with masking tape or a template.

(5) Apply the epoxy through the slit in the masking tape or template. Overlap both ends of the break by at least 19 millimeters (0.75 inch).

(6) For a terminal or pigtail wire replacement, mask the adjacent areas so the epoxy can be extended onto the adjacent grid line as well as the bus bar. Apply a thin layer of epoxy to the area where the terminal or pigtail wire was fastened and onto the adjacent grid line.

(7) Apply a thin layer of conductive epoxy to the terminal or bare wire end of the pigtail and place it in the proper location on the bus bar. To prevent the terminal or pigtail wire from moving while the epoxy is curing, it must be wedged or clamped.

(8) Carefully remove the masking tape or template.

**CAUTION: Do not allow the glass surface to exceed 204° C (400° F) or the glass may fracture.**

(9) Allow the epoxy to cure 24 hours at room temperature, or use a heat gun with a 260° to 371° C (500° to 700° F) range for fifteen minutes. Hold the heat gun approximately 25.4 centimeters (10 inches) from the repair.

(10) After the conductive epoxy is properly cured, remove the wedge or clamp from the terminal or pigtail wire. Do not attach the wire harness connectors until the curing process is complete.

(11) Check the operation of the rear window defogger glass heating grid.

## REMOVAL AND INSTALLATION

## DEFOGGER SWITCH

**WARNING: ON VEHICLES EQUIPPED WITH AIRBAGS, REFER TO GROUP 8M - PASSIVE RESTRAINT SYSTEMS BEFORE ATTEMPTING ANY STEERING WHEEL, STEERING COLUMN, OR INSTRUMENT PANEL COMPONENT DIAGNOSIS OR SERVICE. FAILURE TO TAKE THE PROPER PRECAUTIONS COULD RESULT IN ACCIDENTAL AIRBAG DEPLOYMENT AND POSSIBLE PERSONAL INJURY.**

(1) Disconnect and isolate the battery negative cable.

REMOVAL AND INSTALLATION (Continued)

(2) Remove the center bezel from the instrument panel. See Instrument Panel Center Bezel in Group 8E - Instrument Panel Systems for the procedures.

(3) Remove the three screws that secure the accessory switch bezel to the instrument panel (Fig. 5).

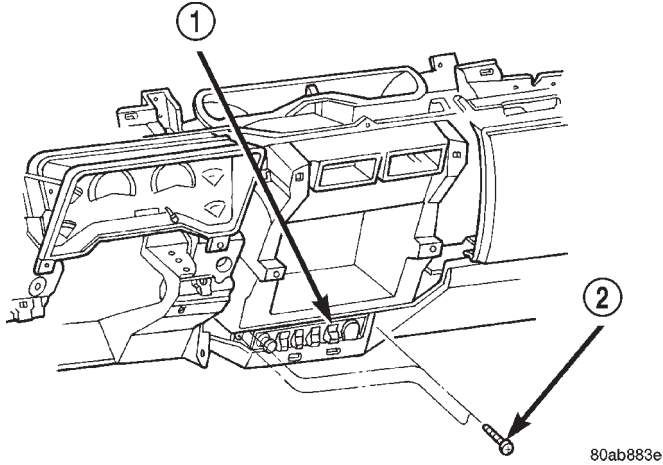

**Fig. 5 Accessory Switch Bezel Remove/Install**

- 1 - ACCESSORY SWITCH BEZEL
- 2 - SCREW

(4) Pull the accessory switch bezel out from the instrument panel far enough to access the wire harness connectors.

(5) Unplug the wire harness connectors from the rear of the accessory switches and the cigar lighter/power outlet.

(6) Remove the accessory switch bezel from the instrument panel.

(7) With a small thin-bladed screwdriver, gently pry the snap clips at the top and bottom of the rear window defogger switch receptacle on the back of the accessory switch bezel and pull the switch out of the bezel.

(8) Reverse the removal procedures to install. Be certain that both of the switch snap retainers in the receptacle on the back of the accessory switch bezel are fully engaged. Tighten the mounting screws to 2.2 N·m (20 in. lbs.).

**DEFOGGER RELAY**

**WARNING: ON VEHICLES EQUIPPED WITH AIRBAGS, REFER TO GROUP 8M - PASSIVE RESTRAINT SYSTEMS BEFORE ATTEMPTING ANY STEERING WHEEL, STEERING COLUMN, OR INSTRUMENT PANEL COMPONENT DIAGNOSIS OR SERVICE. FAILURE TO TAKE THE PROPER PRECAUTIONS COULD RESULT IN ACCIDENTAL AIRBAG DEPLOYMENT AND POSSIBLE PERSONAL INJURY.**

- (1) Disconnect and isolate the battery negative cable.
- (2) Remove the fuse access panel by unsnapping it from the right cowl side trim panel.

(3) Remove the stamped nut that secures the right cowl side trim to the junction block stud (Fig. 6).

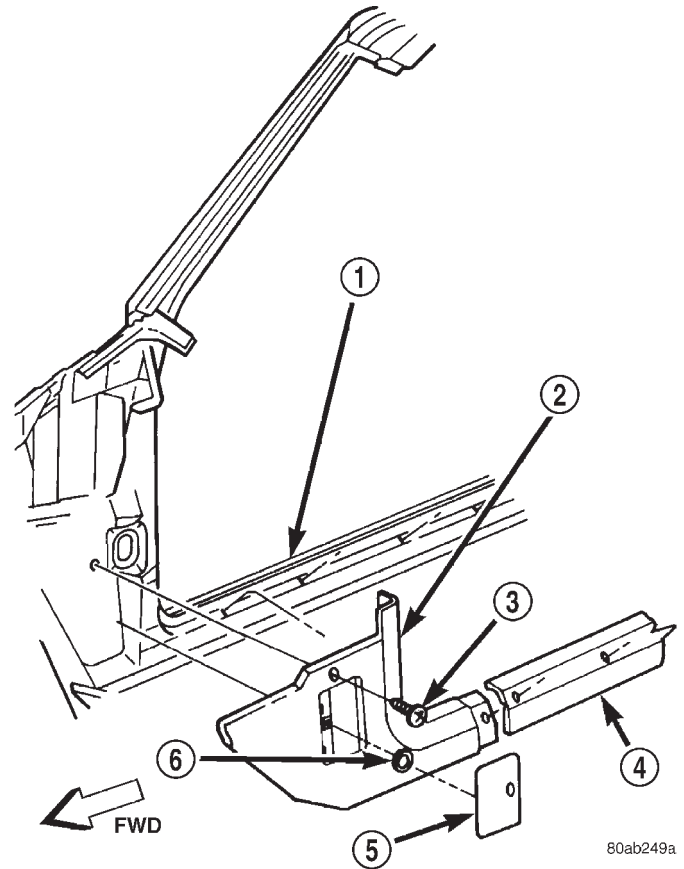

**Fig. 6 Right Cowl Side Trim Remove/Install**

- 1 - RIGHT FRONT DOOR SILL
- 2 - COWL SIDE TRIM PANEL
- 3 - SCREW
- 4 - SILL TRIM
- 5 - FUSE ACCESS PANEL
- 6 - PUSH-NUT

(4) Remove the screw located above the fuse access opening that secures the right cowl side trim to the right cowl side inner panel.

(5) Remove the screw that secures the right door sill trim and the right cowl side trim to the right door opening sill.

(6) Remove the right cowl side trim panel from the vehicle.

(7) Unplug the rear window defogger relay from the junction block.

(8) Install the defogger relay by aligning the relay terminals with the cavities in the junction block and pushing the relay firmly into place.

(9) Connect the battery negative cable.

(10) Test the relay operation.

(11) Reinstall the right cowl side trim and the fuse access panel. Tighten the mounting screws to 2.2 N·m (20 in. lbs.).

# HEATED SEAT SYSTEM

## TABLE OF CONTENTS

	page		page
<b>GENERAL INFORMATION</b>		HEATED SEAT SWITCH.....	10
INTRODUCTION .....	8	HEATED SEAT ELEMENT and SENSOR.....	11
<b>DESCRIPTION AND OPERATION</b>		HEATED SEAT RELAY .....	11
HEATED SEAT SWITCH.....	8	SEAT HEAT INTERFACE MODULE.....	12
SEAT HEAT INTERFACE MODULE.....	9	<b>REMOVAL AND INSTALLATION</b>	
HEATED SEAT RELAY.....	9	HEATED SEAT SWITCH.....	12
HEATED SEAT ELEMENT and SENSOR .....	9	SEAT HEAT INTERFACE MODULE.....	12
<b>DIAGNOSIS AND TESTING</b>		HEATED SEAT RELAY .....	12
HEATED SEAT SYSTEM .....	9		

## GENERAL INFORMATION

### INTRODUCTION

Individually controlled electrically heated front seats are available factory-installed optional equipment on this model. The seat heaters will only operate when the ignition switch is in the ON position, and the surface temperature at the front seat heating element sensors is below the designed temperature set points of the system. The heated seat system will not operate in ambient temperatures greater than about 32° C (90° F).

There are separate momentary, tactile, two-directional rocker switches located in the center console with center NEUTRAL, HI and LO positions for each front seat. Depressing the rocker switch to its momentary HI or LO position signals the Seat Heat Interface Module (SHIM) to power the selected heated seat and maintain the requested temperature setting (HI or LO). Each switch has a HI and LO Light-Emitting Diode (LED) which, via the SHIM, illuminates to give a visual indication that the system is in the HI or LO mode. The LO heat set point is about 32° C (90° F), and the HI heat set point is about 38° C (100° F). The system shall be deactivated whenever the same set position is depressed a second time and shall change states directly when switching from HI to LO or vice versa. The system shall be deactivated whenever the ignition switch is placed in the off position. When the ignition switch is placed back in the run position, the heated seat system shall remain deactivated until a momentary switch is depressed. When a seat heater is turned on, a sensor located near the seat cushion electric heater element provides the SHIM with input indicating the surface temperature of the seat cushion. If the surface temperature input is below the temperature set point of the SHIM for the selected temperature setting, an

N-FET Transistor within the SHIM energizes the heating elements in the seat cushion and back. When the sensor input indicates the correct temperature set point has been achieved, the SHIM de-energizes the N-FET. The SHIM will continue to cycle the N-FET as needed to maintain the temperature set point.

The SHIM will automatically turn off the heating elements if it detects a short or an open in the heating element or a sensor out of range. These conditions will also cause the SHIM to notify the occupant of the failure via flashing the heated seat switch LED's as discussed later.

Switched battery power to the SHIM is supplied by the heated seat relay mounted to the seat cushion frame with the SHIM under the right front seat. The battery feed is protected by a circuit breaker located in the junction block.

Following are general descriptions of the major components in the heated seat system. Refer to 8W-63 - Power Seat With Heated Seats in Group 8W - Wiring Diagrams for complete circuit descriptions and diagrams.

## DESCRIPTION AND OPERATION

### HEATED SEAT SWITCH

The heated seat switch assembly is located on the center console where the ashtray is normally located (Fig. 1). The two momentary, two-directional rocker switches, one switch for each front seat, provide a resistor-multiplexed signal to the Seat Heat Interface Module (SHIM). Each switch has center NEUTRAL, and momentary LO and HI positions so that both the driver and the front seat passenger can select a preferred seat heating mode.

Each switch has two telltales (LED's) which indicate the mode of the heater of the respective seat.



## DESCRIPTION AND OPERATION (Continued)

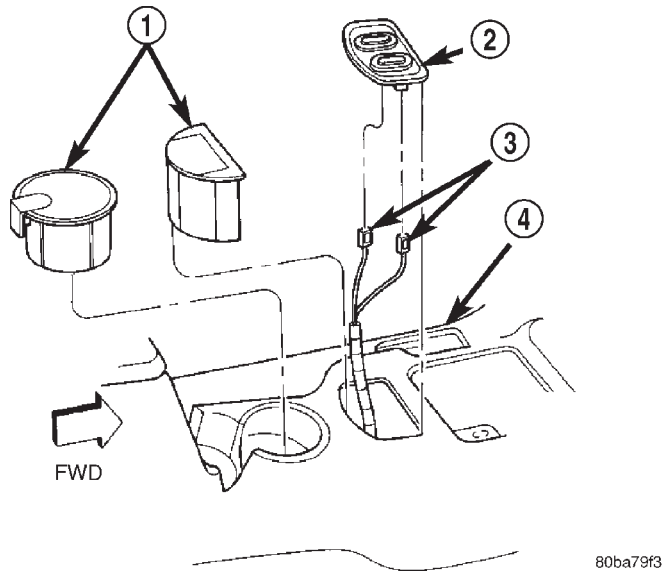

**Fig. 1 Heated Seat Switch Location**

- 1 - ASH RECEIVER
- 2 - HEATED SEAT SWITCHES & BEZEL
- 3 - WIRE HARNESS CONNECTORS
- 4 - FLOOR CONSOLE

The switches also have LED's which provide back-lighting when the ignition switch is in the ON position. The LED's cannot be repaired. If the LED is faulty, the individual switch must be replaced.

### SEAT HEAT INTERFACE MODULE

The Seat Heat Interface Module (SHIM) is an electronic microprocessor controlled device designed to operate the electric seat heater elements. The SHIM is located under the right front seat cushion. Inputs to the module include the console mounted resistor multiplexed switch signals, seat cushion temperature sensors, a relay-switched battery feed, and a ground. The SHIM outputs are the feed for the seat heating elements and sensors, and the switch telltale circuits. The SHIM cannot be repaired and, if faulty or damaged, it must be replaced.

### HEATED SEAT RELAY

The heated seat relay is located under the right front seat cushion near the SHIM. Ignition and battery power is fed to the relay, which then provides a switched battery feed to the SHIM. The heated seat relay cannot be repaired and, if faulty or damaged, it must be replaced.

### HEATED SEAT ELEMENT and SENSOR

Two heated seat heating elements are used in each front seat, one for the seat cushion and the other for the seat back. The two elements for each seat are connected in series with the SHIM.

The temperature sensor is a Negative Temperature Coefficient (NTC) thermistor. One temperature sensor is used for each seat, and it is integral to the seat cushion heating element.

The heating elements are sewn into the seat cushion cover and seat back cover assemblies, which are serviced individually. The heating elements and temperature sensor cannot be repaired and, if faulty or damaged, the affected seat cover assembly must be replaced. Refer to Group 23 - Body for the seat cushion cover and seat back cover Removal and Installation.

### DIAGNOSIS AND TESTING

#### HEATED SEAT SYSTEM

For circuit descriptions and diagrams, refer to 8W - 63 - Power Seat With Heated Seats in Group 8W - Wiring Diagrams.

**WARNING: ON VEHICLES EQUIPPED WITH AIRBAGS, REFER TO GROUP 8M - PASSIVE RESTRAINT SYSTEMS BEFORE ATTEMPTING ANY STEERING WHEEL, STEERING COLUMN, OR INSTRUMENT PANEL COMPONENT DIAGNOSIS OR SERVICE. FAILURE TO TAKE THE PROPER PRECAUTIONS COULD RESULT IN ACCIDENTAL AIRBAG DEPLOYMENT AND POSSIBLE PERSONAL INJURY.**

The heated seat system is capable of performing some self-diagnostics. The following table depicts the various failure modes which will be reported to the occupant via flashing the momentary switch telltales. The switch telltales will flash on the driver's switch if the failure exists in the driver's seat portion of the system, similarly with the passenger's switch. The telltale will illuminate for approximately a 1/2second on, 1/2second off pulse for a duration of one minute. This process will repeat every time the system is initiated via the switches until the problem has been corrected.

## DIAGNOSIS AND TESTING (Continued)

## SEAT HEAT INTERFACE MODULE DIAGNOSTIC ROUTINES

FAILURE MODE	SWITCH "HI" TELLTALE	SWITCH "LO" TELLTALE
Shorted Heating Element	Flashing	Flashing
Open Heating Element	Flashing	Off
NTC Value Out of Range	Off	Flashing

Before testing the individual components in the heated seat system, check the following:

- If the heated seat switch backlighting does not illuminate with the ignition switch in the ON position, check the fuse in the junction block. If the fuse is OK, see Heated Seat Switch Backlighting in the Diagnosis and Testing section of this group. If not OK, repair the shorted circuit or component as required and replace the faulty fuse.

- If the heated seat switch telltales do not illuminate with the ignition switch in the ON position, but the heating elements do heat, see Heated Seat Switch Telltales in the Diagnosis and Testing section of this group.

- If the heated seat switch backlighting illuminates with the ignition switch in the ON position, but the heating elements do not heat and the telltales do not illuminate, check the circuit breaker in the junction block. If the circuit breaker is OK, see Heated Seat Switch Multiplexed Resistances in the Diagnosis and Testing section of this group. If not OK, replace the faulty circuit breaker.

- If the heated seat switch backlighting illuminates and the telltales illuminate, but the heating elements do not heat; see Heated Seat Element in the Diagnosis and Testing section of this group.

## HEATED SEAT SWITCH

For circuit descriptions and diagrams, refer to 8W - 63 - Power Seat With Heated Seats in Group 8W - Wiring Diagrams.

**WARNING: ON VEHICLES EQUIPPED WITH AIRBAGS, REFER TO GROUP 8M - PASSIVE RESTRAINT SYSTEMS BEFORE ATTEMPTING ANY STEERING WHEEL, STEERING COLUMN, OR INSTRUMENT PANEL COMPONENT DIAGNOSIS OR SERVICE. FAILURE TO TAKE THE PROPER PRECAUTIONS COULD RESULT IN ACCIDENTAL AIRBAG DEPLOYMENT AND POSSIBLE PERSONAL INJURY.**

## BACKLIGHTING

(1) Disconnect and isolate the battery negative cable

(2) Remove the heated seat switch assembly from the center console. Remove the connector from the

suspect switch. Check for continuity between the ground circuit cavity of the 6-way heated seat switch wire harness connector and a good ground. There should be continuity. If OK, go to Step 3. If not OK, repair the open circuit as required.

(3) Connect the battery negative cable. Turn the ignition switch to the ON position. Check for battery voltage at the fused ignition switch output circuit cavity of the 6-way heated seat switch wire harness connector. If OK, turn the ignition switch to the OFF position, disconnect and isolate the battery negative cable, and replace the heated seat switch. If not OK, repair the open circuit as required.

## TELLTALES

(1) Replace the heated seat switch with a known good unit and test the operation of the switch telltales. If OK, discard the faulty heated seat switch. If not OK, see Seat Heat Interface Module in the Diagnosis and Testing section of this group.

## MULTIPLEXED RESISTANCES

(1) Disconnect and isolate the battery negative cable.

(2) Remove the heated seat switch assembly from the center console. Remove the connector from the suspect switch.

(3) With the suspect heated seat switch in the NEUTRAL position, using an ohmmeter, measure the resistance between the fused ignition switch output circuit terminal and the heated seat switch output circuit terminal in the 6-way connector receptacle on the back of the switch. The resistance reading should be about 2.2 Kohms. If OK, go to Step 4. If not OK, replace the faulty switch.

(4) Hold the suspect heated seat switch in the LO position. Using an ohmmeter, check the resistance between the fused ignition switch output circuit terminal and the heated seat switch output circuit terminal in the 6-way connector receptacle on the back of the switch. The resistance reading should be about 414 Ohms. If OK, go to Step 5. If not OK, replace the faulty switch.

(5) Hold the suspect heated seat switch in the HI position. Using an ohmmeter, check the resistance between the fused ignition switch output circuit terminal and the heated seat switch output circuit terminal in the 6-way connector receptacle on the back

## DIAGNOSIS AND TESTING (Continued)

of the switch. The resistance reading should be about 32.5 Ohms. If OK, see Heated Seat Relay in the Diagnosis and Testing section of this group. If not OK, replace the faulty switch.

### HEATED SEAT ELEMENT and SENSOR

The wire harness connectors for the seat cushion and seat back heating elements are located under the seat, near the rear edge of the seat cushion frame. For circuit descriptions and diagrams, refer to 8W - 63 - Power Seat With Heated Seats in Group 8W - Wiring Diagrams.

#### SEAT CUSHION

(1) Disconnect and isolate the battery negative cable. Unplug the 4-way heated seat cushion wire harness connector.

(2) Check for continuity between the two heated seat element circuit cavities of the seat cushion cover half of the heated seat cushion wire harness connector. There should be continuity. If OK, go to Step 3. If not OK, replace the faulty seat cushion cover.

(3) Check for continuity between one of the heated seat element circuit cavities of the seat cushion cover half of the heated seat cushion wire harness connector and the seat cushion frame. There should be no continuity. If OK, see Seat Back in the Diagnosis and Testing section of this group. If not OK, replace the faulty seat cushion cover.

#### SEAT BACK

(1) Disconnect and isolate the battery negative cable. Unplug the 2-way heated seat back wire harness connector.

(2) Check for continuity between the heated seat element circuit cavity and the ground circuit cavity of the seat back cover half of the heated seat back wire harness connector. There should be continuity. If OK, go to Step 3. If not OK, replace the faulty seat back cover.

(3) Check for continuity between the heated seat element circuit cavity of the seat back cover half of the heated seat back wire harness connector and the seat back frame. There should be no continuity. If OK, see Heated Seat Sensor in the Diagnosis and Testing section of this group. If not OK, replace the faulty seat back cover.

### HEATED SEAT SENSOR

The wire harness connector for the seat cushion heating element and sensor are located under the seat, near the rear edge of the seat cushion frame. For circuit descriptions and diagrams, refer to 8W - 63 - Power Seat With Heated Seats in Group 8W - Wiring Diagrams.

(1) Disconnect and isolate the battery negative cable. Unplug the 4-way heated seat cushion wire harness connector.

(2) Using an ohmmeter, check the resistance between the heated seat sensor input circuit cavity and the heated seat sensor feed circuit cavity of the seat cushion cover half of the heated seat cushion wire harness connector. The sensor resistance should be between 1 Kohm and 200 Kohms. If OK, see Heated Seat Relay in the Diagnosis and Testing section of this group. If not OK, replace the faulty seat cushion cover.

### HEATED SEAT RELAY

For circuit descriptions and diagrams, refer to 8W - 63 - Power Seat With Heated Seats in Group 8W - Wiring Diagrams.

(1) Disconnect and isolate the battery negative cable. Unplug the 8-way heated seat relay connector.

(2) Check for continuity between the ground circuit cavity of the 8-way heated seat relay wire harness connector and a good ground. There should be continuity. If OK, go to Step 3. If not OK, repair the open circuit as required.

(3) Connect the battery negative cable. Check for battery voltage at the battery feed circuit cavity (pin 8) of the 8-way heated seat relay wire harness connector. If OK, go to Step 4. If not OK, repair the open circuit as required.

(4) Turn the ignition switch to the ON position. Check for battery voltage at the fused ignition switch output circuit cavity of the 8-way heated seat relay wire harness connector. If OK, turn the ignition switch to the OFF position, disconnect and isolate the battery negative cable, and go to Step 5. If not OK, repair the open circuit as required.

(5) Unplug the 14-way seat heat interface module (SHIM) connector. Check for continuity between the two switched battery feed cavities of the 14-way SHIM wire harness connector and the switched battery feed cavity of the 8-way heated seat relay wire harness connector. If OK, reconnect the heated seat relay wire harness connector, and go to Step 6. If not OK, repair the open circuit as required.

(6) Connect the battery negative cable. Turn the ignition switch to the ON position. Check for battery voltage at the switched battery feed cavities of the 14-way SHIM wire harness connector. If OK, turn the ignition switch to the OFF position, disconnect and isolate the battery negative cable, and see Seat Heat Interface Module in the diagnosis and testing section of this group. If not OK, replace the heated seat relay.

## DIAGNOSIS AND TESTING (Continued)

**SEAT HEAT INTERFACE MODULE**

Before testing the seat heat interface module, test the heated seat switch, the heated seat elements, and the heated seat sensor as described in the Diagnosis and Testing section of this group. If testing of the heated seat switch, elements, and sensor reveals no problems, proceed as follows. For circuit descriptions and diagrams, refer to 8W - 63 - Power Seat With Heated Seats in Group 8W - Wiring Diagrams.

(1) Replace the seat heat interface module with a known good unit and test the operation of the heated seats. If OK, discard the faulty seat heat interface module. If not OK, go to Step 2.

(2) Test each of the circuits from the heated seat switch, heated seat relay, heated seat elements, and heated seat sensor to the seat heat interface module. Repair any short or open circuits as required.

**REMOVAL AND INSTALLATION****HEATED SEAT SWITCH**

**WARNING: ON VEHICLES EQUIPPED WITH AIR-BAGS, REFER TO GROUP 8M - PASSIVE RESTRAINT SYSTEMS BEFORE ATTEMPTING ANY STEERING WHEEL, STEERING COLUMN, OR INSTRUMENT PANEL COMPONENT DIAGNOSIS OR SERVICE. FAILURE TO TAKE THE PROPER PRECAUTIONS COULD RESULT IN ACCIDENTAL AIR-BAG DEPLOYMENT AND POSSIBLE PERSONAL INJURY.**

(1) Disconnect and isolate the battery negative cable.

(2) Using a trim stick or another suitable wide flat-bladed tool, gently pry around the perimeter edges of the heated switch assembly bezel to release the assembly from the console. Remove the assembly from the console.

(3) Pull the switch assembly out from the console far enough to access and unplug the wire harness connectors.

(4) Remove the heated seat switch assembly from the console.

(5) Remove the heated seat switch(es) from the heated seat switch assembly.

(6) Reverse the removal procedures to install.

**SEAT HEAT INTERFACE MODULE**

(1) Move the right power seat adjuster to its full up and full rear stop positions.

(2) Disconnect and isolate the battery negative cable.

(3) Unhook the seat cushion cover retainer from the seat cushion frame and pull back the seat cushion cover.

(4) Pull back the seat cushion to allow access to the Seat Heat Interface Module (SHIM).

(5) Pull the SHIM upward to release the two mounting fasteners from either the module or the mounting bracket. Unplug the wire harness connector from the module (Fig. 2).

**WARNING: THERE ARE MANY SHARP METAL EDGES ON THE SEAT CUSHION FRAME AND SEAT ADJUSTER RAILS UNDER THE SEAT. WHEN PERFORMING THIS SERVICE, A LONG-SLEEVED SHIRT AND GLOVES SHOULD BE WORN IN ORDER TO AVOID UNNECESSARY CUTS AND ABRASIONS TO EXPOSED SKIN.**

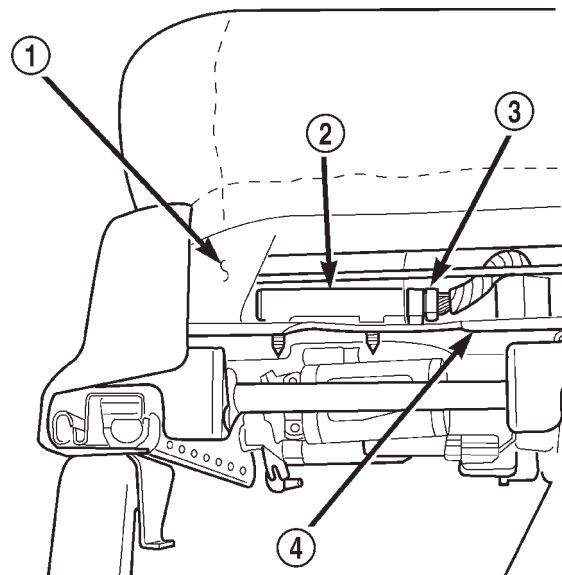

80bcea01

**Fig. 2 Seat Heat Interface Module Remove/Install**

- 1 - SEAT CUSHION FRAME
- 2 - SEAT HEAT INTERFACE MODULE
- 3 - WIRE HARNESS CONNECTOR
- 4 - POWER SEAT TRACK FRONT BRACKET

(6) Reverse the removal procedures to install. Be certain that the SHIM terminals are aligned with the cavities in the wire harness connector before pushing the module firmly into place.

**HEATED SEAT RELAY**

(1) Move the right power seat adjuster to its full up and full rear stop positions.

(2) Disconnect and isolate the battery negative cable.

(3) Unhook the seat cushion cover retainer from the seat cushion frame and pull back the seat cushion cover.

(4) Pull back the seat cushion to allow access to the Heated Seat Relay.

## REMOVAL AND INSTALLATION (Continued)

(5) Cut the Christmas tree fastener to remove the Heated Seat Relay fastener from the mounting bracket. Unplug the wire harness connector from the relay (Fig. 3).

(6) Reverse the removal procedures to install. A new Christmas tree fastener must be used to mount the relay. Be certain that the relay terminals are aligned with the cavities in the wire harness connector before pushing the relay firmly into place.

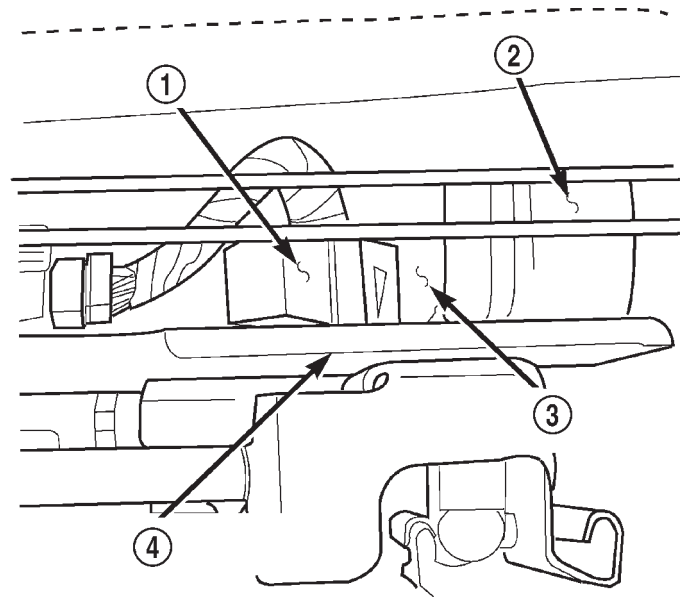

80bcea00

**Fig. 3 Heated Seat Relay Remove/Install**

- 1 - HEATED SEAT RELAY
- 2 - SEAT CUSHION FRAME
- 3 - WIRE HARNESS CONNECTOR
- 4 - POWER SEAT TRACK FRONT BRACKET

