

# ALTERNATOR - NIPPONDENSO

1993 Jeep Cherokee

1993 ELECTRICAL  
Chrysler Corp. Alternators - Nippondenso

Cherokee, Grand Cherokee, Grand Wagoneer, Wrangler

## DESCRIPTION

Charging system consists of a Powertrain Control Module (PCM), alternator, CHECK ENGINE light and battery. Voltage regulation is controlled within the PCM and cannot be serviced.

The PCM monitors charging system input and output to ensure correct operation. The PCM stores any charging system failures in memory and outputs fault code(s) when on-board diagnostics are entered.

The PCM monitors several different engine control system circuits. If a problem is detected within a monitored circuit, a fault code is stored in the PCM memory. The CHECK ENGINE light will illuminate and system may enter limp-in mode. In limp-in mode, engine controller compensates for component or circuit failure by using information from other sources until repairs are made.

NOTE: Fault codes remain in memory for 50 engine starts. Fault is erased from memory if failure does not reoccur.

## ADJUSTMENTS

### BELT TENSION

BELT ADJUSTMENT TABLE (1)

Application	Lbs. (kg)
New Belt .....	180-200 (81.72-90.8)
Used Belt .....	140-160 (63.56-72.64)

(1) - Tension in lbs. (kg) using belt tension gauge.

## TROUBLE SHOOTING

### PRELIMINARY CHECKS

Visually inspect wiring and drive belts. If charging system is not working, ensure drive belts are properly tightened. Ensure 12 volts exist at alternator field terminal with ignition on. Ensure battery cables, alternator ground cables and alternator and terminal block connections are clean and tight. Ensure alternator field circuit is not grounded (overcharging).

### UNSTEADY OR LOW CHARGING

Check for loose alternator belt, defective alternator, loose alternator ground wire or corroded battery terminals.

### OVERCHARGING

Check for grounded alternator field wiring or faulty

alternator.

## TESTING (ON-VEHICLE)

### ALTERNATOR OUTPUT

#### Output Wire Resistance (Voltage Drop) Test

1) Ensure battery is charged. Turn ignition off. Disconnect negative battery cable. Connect a 0-150 DC ammeter and a voltmeter (0-18 volts) to vehicle's charging system. See Fig. 1.

2) Connect a carbon pile rheostat between battery terminals. Ensure carbon pile is in OFF position before connecting leads.

CAUTION: Alternator has 2 field terminals. In step 3), DO NOT connect jumper wire to alternator field terminal Dark Green/Orange wire.

3) Connect one end of jumper wire to ground and other end to alternator field terminal Dark Green wire on rear side of alternator. See Fig. 2. Connect negative battery cable.

4) Start engine. Reduce engine speed to idle. Adjust engine speed and carbon pile to maintain 20-amp current flow. Observe voltmeter reading. Voltage drop should be .5 volt or less.

5) If voltage drop is greater than .5 volt, inspect, clean and tighten all connections between alternator BAT (B+) terminal and positive battery post. If wire resistance (voltage drop) is okay, test is complete. Remove all test equipment.

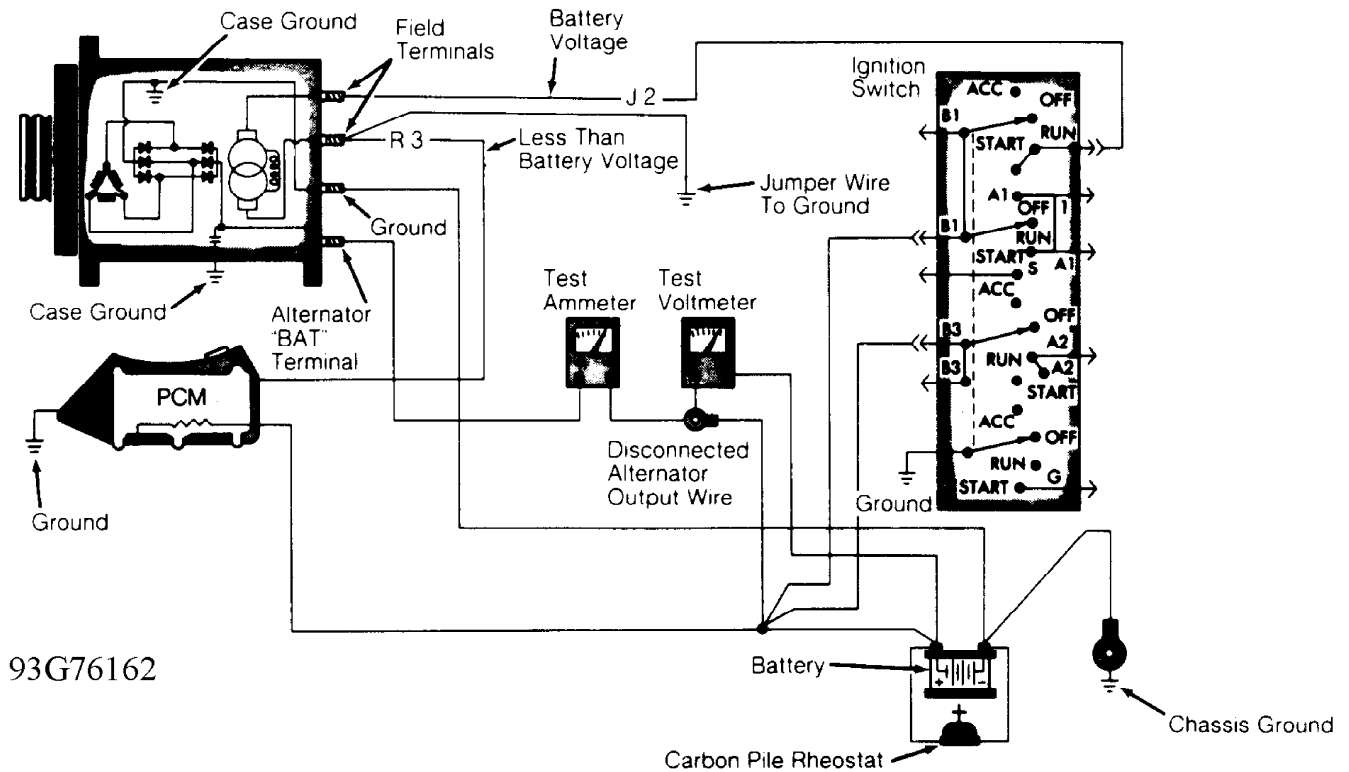

Fig. 1: Testing Alternator Output Wire Resistance (Typical)  
Courtesy of Chrysler Corp.

#### Current Output Test

1) Ensure battery is charged. Turn ignition off. Disconnect

negative battery cable. Connect a 0-150 DC ammeter and a voltmeter (0-18 volts) to vehicle charging system. See Fig. 3.

2) Connect a carbon pile rheostat between battery terminals. Ensure carbon pile is in OFF position before connecting leads.

**CAUTION:** Alternator has 2 field terminals. In step 3), DO NOT connect jumper wire to alternator field terminal Dark Green/Orange wire.

3) Connect one end of jumper wire to ground and other end to alternator field terminal Dark Green wire on rear side of alternator. See Fig. 2. Connect negative battery cable.

4) Start engine and reduce engine speed to idle. Adjust carbon pile and engine speed until engine speed is 1250 RPM and voltmeter reads 15 volts. DO NOT allow voltage to read greater than 16 volts.

5) Ammeter should read within 10 amps of rating listed on back of alternator. If reading is not as specified, replace alternator. Remove all test equipment.

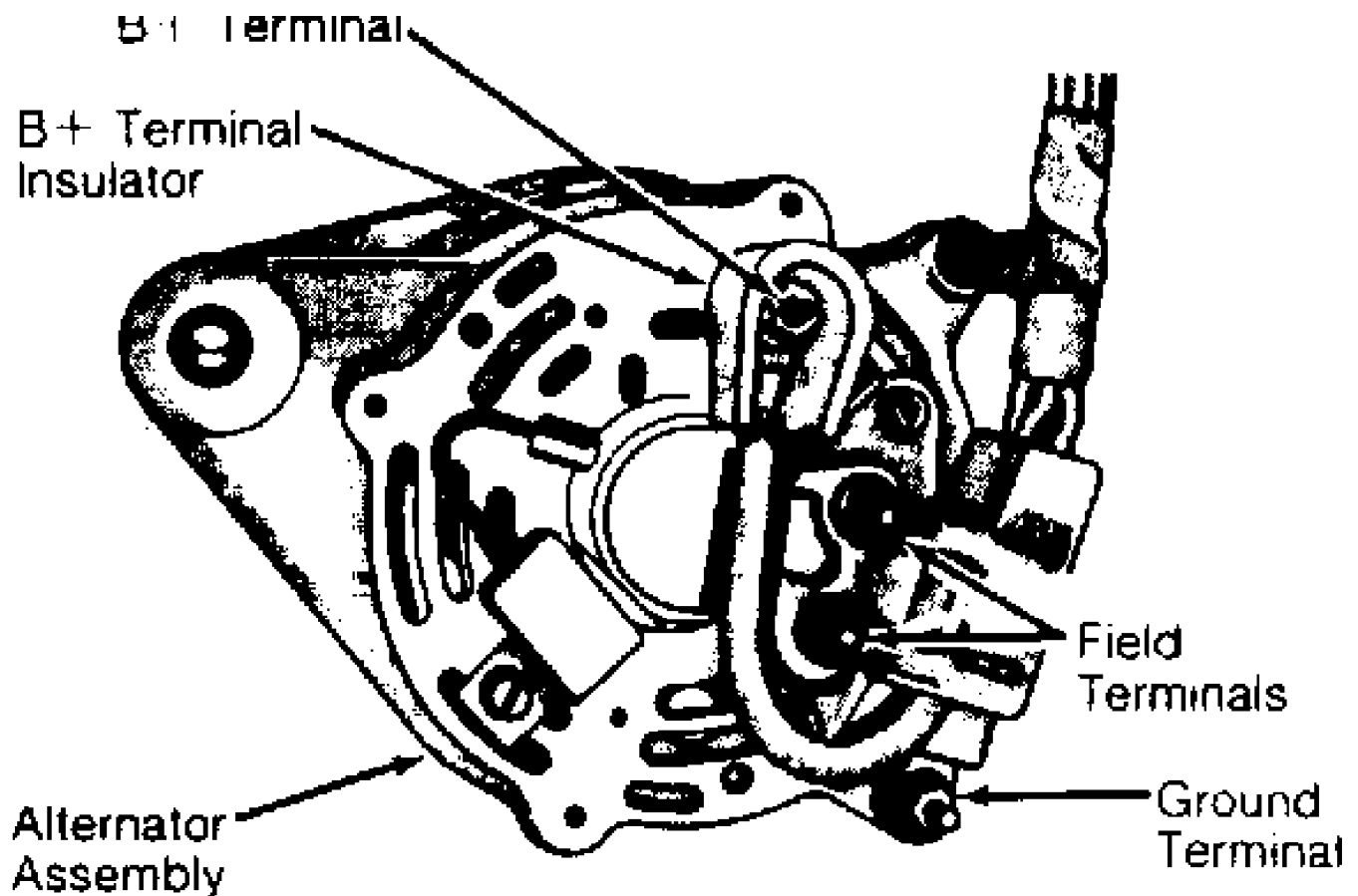
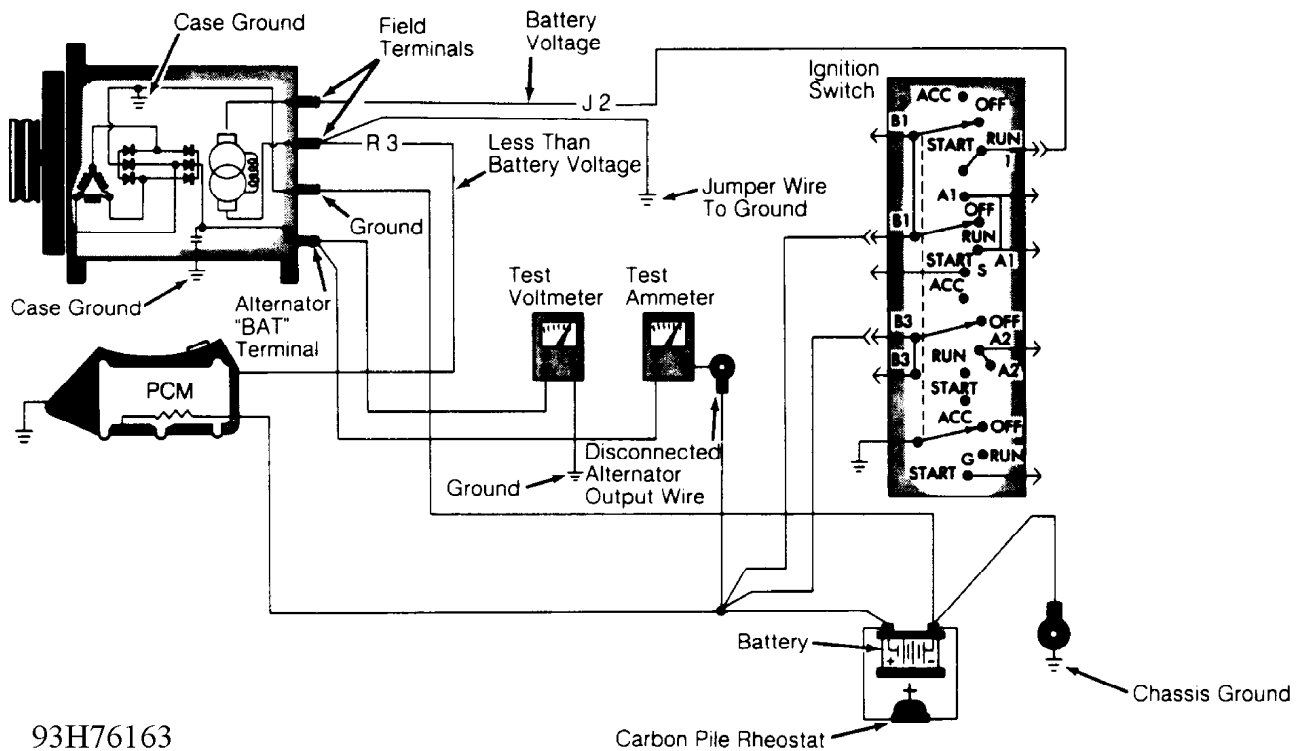

Fig. 2: Identifying Alternator Terminals  
Courtesy of Chrysler Corp.



93H76163

Fig. 3: Testing Alternator Current Output (Typical)  
 Courtesy of Chrysler Corp.

## ENTERING ON-BOARD DIAGNOSTICS

**CAUTION:** Before entering on-board diagnostics, check charging system for other problems. See PRELIMINARY CHECKS under TROUBLE SHOOTING. DO NOT connect DRB-II to vehicle with battery charger connected. Damage to DRB-II may result.

### Reading Trouble Codes

Trouble codes may be read by using the CHECK ENGINE light on instrument panel or using DRB-II. See CHECK ENGINE LIGHT DIAGNOSTIC MODE and DIAGNOSIS USING DRB-II headings below. A more complete diagnosis is possible using DRB-II.

**NOTE:** The PCM CANNOT diagnose every charging system problem. If a fault still exists after performing self-diagnostic procedures, go to TESTING (ON-VEHICLE).

### Trouble Code Explanation

- 1) See the CHARGING SYSTEM FAULT CODES table for charging-related faults.
- 2) Code 41 will set if alternator field control fails to switch properly. PCM monitors this circuit whenever ignition is on.
- 3) If battery temperature sense voltage goes out of range, Code 44 will set in memory. PCM monitors this circuit any time ignition is on.
- 4) If battery voltage is more than one volt above desired control voltage for longer than 20 seconds, Code 46 will be set in memory. PCM monitors this signal whenever engine is running.
- 5) If battery is more than one volt below desired control voltage for more than 20 seconds, Code 47 will be set. Code 47 will also set if no significant change in voltage is detected during alternator test. PCM monitors this signal whenever engine speed is

more than 1500 RPM.

#### CHARGING SYSTEM FAULT CODES TABLE

Code	Circuit	Light Status
41 (1)	..... Alternator Field Control .....	On
44 (1)	..... (2) Battery Temp. Sensor .....	On
46 (1)	..... High Battery Voltage .....	On
47 (1)	..... Low Battery Voltage .....	Off
55	..... End Of Diagnostic Mode .....	Off

- (1) - This code will cause limp-in mode.  
(2) - Sensor inside PCM. If failed, replace PCM.

NOTE: Only charging system-related codes are listed here. For engine-related codes, see appropriate G - TESTS W/CODES article in the ENGINE PERFORMANCE Section.

#### CHECK ENGINE Light Diagnostic Mode

1) Start engine (if possible). On models equipped with automatic transmission, place foot on brake and cycle transmission shift lever through all positions, ending in Park. On all models, turn A/C switch on and then off (if equipped).

2) Turn engine off. Without starting engine, turn ignition on, off, on, off and on. CHECK ENGINE light will come on for 2 seconds as a bulb check, followed by fault codes. Record 2-digit fault codes as displayed by flashing CHECK ENGINE light.

3) Once CHECK ENGINE light begins to flash fault codes, it cannot be stopped. Repeat step 1) to enter diagnostic mode. Code 55 indicates end of fault code display. For more information on vehicle self-diagnostics, see appropriate SELF-DIAGNOSTICS article in the ENGINE PERFORMANCE section.

4) Refer to CHARGING SYSTEM FAULT CODES table to relate trouble code number to a system fault description (DRB-II display). Once trouble area is known, go to appropriate charging system test.

NOTE: CHECK ENGINE light cannot be used to perform actuation test mode, sensor test modes or engine running test. Fault codes can only be erased using DRB-II. Fault codes will be erased from PCM memory after 50 engine starts if fault does not occur again.

#### Diagnosis Using DRB-II

The DRB-II is used as part of the charging system diagnostic procedure. Perform TEST CH-1, BATTERY CONDITION CHECK and also the CHARGING VERIFICATION (CH-VER) test.

#### Erasing Fault Codes

1) To erase faults, press ATM key. At DRB-II display, press "2" (ERASE) key. DRB-II will display ERASE FAULTS ARE YOU SURE? (ENTER TO ERASE). Press ENTER key.

2) When DRB-II is finished erasing fault codes, it will display FAULTS ERASED. This display will remain until ATM key is pressed. After ATM key is pressed, display will return to CHARGING MENU screen.

### DRB-II TEST FUNCTIONS

NOTE: DO NOT touch DRB-II keypad during DRB-II power-up sequence, or an error message will result.

1) To diagnose system with DRB-II, DRB-II must be in CHARGING MENU. At CHARGING MENU, fault codes and DRB-II test functions can be used.

2) To get to CHARGING MENU, turn ignition off. Attach DRB-II to engine diagnostic connector. Connector is located in engine compartment, near PCM. Turn ignition switch to RUN position.

3) All DRB-II character positions will glow and copyright information will appear on screen for several seconds.

4) After several seconds DRB-II menu will appear. At DRB-II menu, press "4" (SELECT SYSTEM) key. Press ENTER key. At SELECT SYSTEM menu, press "1" (ENGINE) key. Press ENTER key. DRB-II menu will appear, indicating engine year and size, type of transmission and PCM part number.

5) After several seconds AIR COND menu will appear. Press "1" (WITH A/C) or press "2" (WITHOUT A/C). DRB-II display will change to ENGINE SYSTEMS menu. At ENGINE SYSTEMS menu, press "2" (CHARGING) key. Press ENTER key.

6) Display will change to CHARGING MENU. At CHARGING menu of engine diagnostic program, specific test functions programmed into DRB-II can be performed. Following DRB-II modes can be accessed: SYSTEM TEST, READ FAULTS, STATE DISPLAYS, ACTUATOR TEST and ADJUSTMENTS.

#### READ FAULTS Mode

This allows technician to read and erase fault codes. Fault counter will appear along with fault displayed on DRB-II. For example, DRB-II will display 1 OF 2 FAULTS. PCM will store up to 8 fault messages.

Faults are numbered in reverse order of setting. Most recent fault to occur will be number one. Vehicles without A/C will always have A/C CLUTCH RELAY CKT (circuit) stored in memory. This fault will always be number one if vehicle is not equipped with A/C. If no fault messages are stored, DRB-II will display NO FAULTS DETECTED and start counter will show 0 STARTS SINCE ERS.

A start counter will appear below DRB-II fault counter display. Start counter counts the number of times vehicle is started since faults were last set, erased or battery was disconnected. This helps determine if fault is intermittent.

Memory space limits start counter to first 3 faults. Start counter of zero equals a hard fault. Start counter of more than zero indicates an intermittent fault. Start counter will count up to 255 starts. If no fault messages are stored, DRB-II will display NO FAULTS DETECTED and start counter will show 0 STARTS SINCE ERS.

#### STATE DISPLAYS Mode

This allows technician to read status or values of sensors, inputs/outputs and components. PCM can only recognize high and low status on switch circuits. PCM cannot detect the difference between an open or short circuit or a defective switch. If DRB-II displays a change between INPUT HIGH and INPUT LOW, it can be assumed that entire switch circuit to PCM is working.

#### ACTUATOR TEST Mode

This function allows the technician to check operation of output circuits or devices, which PCM cannot detect. DRB-II allows PCM to activate these outputs or devices. so technician can check for proper operation.

Most tests available in this mode provide an audible or visual indication of device operation (click of relay contacts, fuel spray, etc.). With exception of an intermittent condition, if a device functions properly during its test, it, its wiring and its driver circuit are presumably working properly.

#### ADJUSTMENTS Mode

This function allows user to erase fault codes. Function also allows user to reset Emission Maintenance Reminder (EMR) light and mileage.

#### DRB-II Volt/Ohmmeter Mode

To access volt/ohmmeter mode of DRB-II, connect Red volt/ohmmeter test lead to Red port, located on right-top side of DRB-II.

**NOTE:** Because DRB-II is grounded through engine diagnostic connector, only one volt/ohmmeter test is required when using volt/ohmmeter option.

To access voltmeter, press VOLT/OHM key once. DRB-II is now in voltmeter mode. Touch test probe to connector or wire to be measured. Read voltage on DRB-II display. When voltage testing is complete, press VOLT/OHM key 3 times to exit voltmeter mode.

To access ohmmeter, press VOLT/OHM key t,vice. DRB-II is now in ohmmeter mode. Touch test probe to connector or wire to be measured. Read resistance to circuit ground on DRB-II display. When resistance testing is complete, press VOLT/OHM key twice to exit ohmmeter mode.

#### DRB-II Continuity Meter Mode

Press VOLT/OHM key 3 times. Display will read NO CONTINUITY. Touch test probe to connector or wire to be measured. Read continuity on DRB-II display. When continuity testing is complete, press VOLT/OHM key once to exit continuity meter mode.

#### VEHICLES TESTED Mode

Mode is used to show what vehicles are covered by DRB-II cartridge. To access VEHICLES TESTED mode, turn ignition off. Attach DRB-II to engine diagnostic connector. Connector is located in engine compartment, near PCM.

Turn ignition switch to RUN position. All DRB-II character positions will glow and copyright information will appear on screen for several seconds. After several seconds DRB-II menu will appear.

At DRB-II menu, press VEHICLES TESTED) key. Press ENTER key. DRB-II will display vehicles covered by cartridge. Screen will display for 5 seconds and return to DRB-II menu.

#### HOW TO USE Mode

Enter DRB-II menu display. Refer to VEHICLES TESTED MODE. At DRB-II menu, press 2 (HOW TO USE) key. Press ENTER key. A series of screens will be displayed explaining use of DRB-II keys used to move through engine diagnostic program.

## TEST CH-1, BATTERY CONDITION CHECK

**NOTE:** Perform PRELIMINARY CHECKS under TROUBLE SHOOTING before proceeding. If battery shows signs of freezing or leakage, battery posts are loose or battery has low electrolyte level, DO NOT test.

1) If battery has a built-in hydrometer, go to step 2). Turn ignition and all accessories off. Ensure battery voltage is 12.0 volts or greater. If voltage is less than 12.0 volts, charge battery and go to step 3).

2) If battery hydrometer is Green, go to step 3). If battery hydrometer is Yellow or a bright color, replace battery and perform CHARGING VERIFICATION (CH-VER) test. If battery hydrometer is dark in color, charge battery and go to next step.

3) Ensure battery cables, terminals and posts are clean and tight. Perform a battery load test by applying a 300-amp load for 15 seconds. Wait 15 seconds to allow battery to stabilize. Apply a load equal to 50 percent of battery cold cranking rating for 15 seconds and record minimum voltage reading.

4) See MINIMUM BATTERY VOLTAGE table. If battery is below volt age, replace battery and perform CHARGING VERIFICATION (CH-VER) test. If voltage reading is okay, go to next step.

#### MINIMUM BATTERY VOLTAGE TABLE

Battery Temperature	Minimum Volts
70°F (21°C) Or More .....	9.6
60°F (16°C) .....	9.5
50°F (10°C) .....	9.4
40°F (4°C) .....	9.3
30°F (-1°C) .....	9.1
20°F (-7°C) .....	8.9
10°F (-12°C) .....	8.7
0°F (-18°C) .....	8.5

5) Reconnect battery cables. Inspect alternator belt tension and condition. Replace belt as necessary. Start engine. Set engine speed to 2000 RPM for 30 seconds. Turn ignition off. Connect DRB-II. Turn ignition on with engine off. Read faults.

6) If DRB-II displays BATTERY TEMP SENSOR OUT OF LIMIT, replace PCM and perform CHARGING VERIFICATION (CH-VER) test. If DRB-II displays other messages, go to appropriate test. If DRB-II does not display any faults, neither fault messages nor faults are intermittent. Go to TEST CH-5, CHECKING FOR INTERMITTENT PROBLEMS.

### TEST CH-2, ALTERNATOR FIELD NOT SWITCHING PROPERLY (CODE 41)

NOTE: Perform TEST CH-1, BATTERY CONDITION CHECK before proceeding.

1) Put DRB-II in voltmeter mode. Check voltage of Automatic Shutdown (ASD) circuit by probing Dark Green/Orange wire (Dark Green/Black wire on Grand Cherokee and Grand Wagoneer) at back of alternator. If voltage is less than 10 volts, repair open circuit from ignition switch. If voltage is 10 volts or greater, go to next step.

2) Check voltage of alternator field driver circuit by probing Dark Green wire at back of alternator. If voltage is less than 10 volts, go to next step. If voltage is 10 volts or greater, go to step 6).

3) Turn ignition off. Disconnect and inspect PCM connector. Repair, if necessary. Disconnect alternator harness from back of alternator. Using an external ohmmeter, check field driver circuit (Dark Green wire) for resistance. If resistance is less than 5.0 ohms, replace PCM. If resistance is 5.0 ohms or greater, repair open in Dark Green wire.

4) Turn ignition off. Disconnect PCM connector. Disconnect alternator harness from back of alternator. Using an external ohmmeter, check for resistance between alternator field terminals. If resistance is 5.0 ohms or greater, replace alternator. If resistance is less than 5.0 ohms, go to next step.

5) With DRB-II in ohmmeter mode, check resistance in field circuit of alternator harness. If resistance is 5.0 ohms or greater, repair short to ground in field driver circuit (Dark Green wire). If resistance is less than 5.0 ohms, replace PCM.

6) Turn ignition off. Disconnect PCM connector. Disconnect alternator harness from back of alternator. Using an external



ohmmeter, check for resistance in field driver circuit alternator harness terminal and cavity No. 20 on PCM connector. See Fig. 4. If resistance is 5.0 ohms or greater, repair short to ground in field driver circuit (Dark Green wire). If resistance is less than 5.0 ohms, replace PCM. Perform CHARGING VERIFICATION (CH-VER) test.

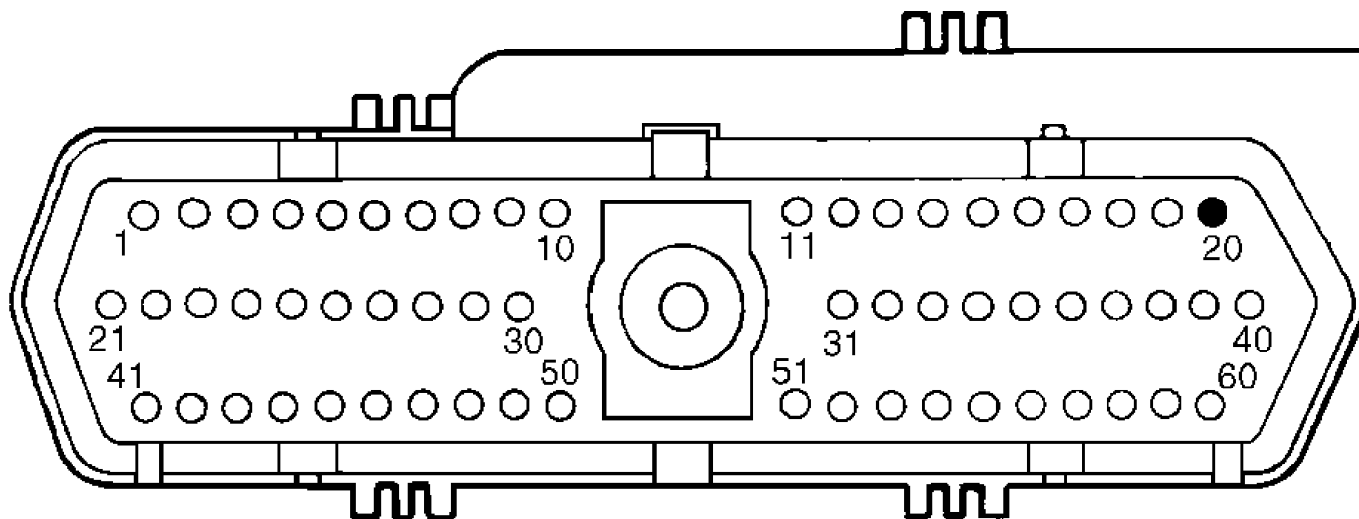

## TERMINAL VIEW OF PCM HARNESS CONNECTOR

93176164

Fig. 4: Identifying PCM Connector Cavities  
Courtesy of Chrysler Corp.

### TEST CH-3, CHARGING SYSTEM VOLTAGE LOW (CODE 47)

NOTE: Perform TEST CH-1, BATTERY CONDITION CHECK before proceeding.

1) If alternator voltage is 15.1 volts or greater, replace PCM. If less than 15.1 volts, ensure no resistance is present between alternator BAT (B+) and battery positive terminal.

CAUTION: Ensure all wires are clear of moving engine parts.

2) Check alternator case for good continuity to ground and negative battery cable. If continuity is good, manually set engine speed to 1600 RPM. Compare voltage on DRB-II and voltage on an external meter. If voltage difference is one volt or greater, replace the alternator. If the difference is less than one volt, proceed to TEST CH-5, CHECKING FOR INTERMITTENT PROBLEMS.

### TEST CH-4, CHARGING SYSTEM VOLTAGE HIGH (CODE 46)

NOTE: Perform TEST CH-1, BATTERY CONDITION CHECK before proceeding.

1) Turn ignition on. Put DRB-II in voltmeter mode. Probe Dark Green wire at back of alternator. If voltage is 10.0 volts or more, go to step 4). If voltage is less than 10.0 volts, turn ignition off. Disconnect PCM connector, inspect and repair if necessary.

2) If connector is okay, turn ignition on. Probe Dark Green wire at back of alternator. If voltage is 10.0 volts or greater, go to step 6). If voltage is less than 10.0 volts, go to next step.

3) Turn ignition off. Disconnect alternator harness from alternator. Put DRB-II in ohmmeter mode. Probe Dark Green wire in

alternator harness. If resistance is less than 10.0 ohms, repair Dark Green wire for short to ground. If resistance is 10.0 ohms or greater, replace alternator. Perform CHARGING VERIFICATION (CH-VER) test.

4) With ignition on and engine off, read voltage. If less than 13.0 volts, replace PCM. Perform CHARGING VERIFICATION (CH-VER) test. If voltage is 13.0 volts or greater, start engine and read voltage. Compare voltage readings before and after engine is running. Watch for a one-volt difference, waiting up to 5 minutes,.

5) If voltage difference is one volt or greater, replace PCM. Perform CHARGING VERIFICATION (CH-VER) test. If difference is less than one volt, go to TEST CH-5, CHECKING FOR INTERMITTENT PROBLEMS.

6) Disconnect negative battery cable. Disconnect PCM connector. Disconnect alternator harness from back of alternator. With DRB-II in ohmmeter mode, check resistance between field driver circuit alternator harness terminal and cavity No. 20 on PCM connector. If resistance is 5.0 ohms or greater, repair short to ground in field driver circuit (Dark Green wire). If resistance is less than 5.0 ohms, go to next step.

7) Probe one of the alternator field terminals. If resistance is 5.0 ohms or greater, replace alternator. If resistance is less than 5.0 ohms, Replace PCM. Perform CHARGING VERIFICATION (CH-VER) test.

## TEST CH-5, CHECKING FOR INTERMITTENT PROBLEMS

NOTE: Perform TEST CH-4, CHARGING SYSTEM VOLTAGE HIGH (CODE 46) before proceeding.

1) Actuate alternator field. Put DRB-II in voltmeter mode. Probe Dark Green wire at back of alternator. Voltage should cycle from zero to battery voltage every 1.4 seconds.

2) While watching DRB-II, wiggle wires between alternator and PCM. If any interruption in the voltage cycle, repair wire at point at which cycle was interrupted. If there is no interruption of voltage cycle, test is complete. Perform CHARGING VERIFICATION (CH-VER) test.

## CHARGING VERIFICATION (CH-VER)

1) Ensure all engine components are connected. If PCM has been changed and if vehicle is equipped with a factory theft alarm system, start vehicle at least 20 times so alarm will activate when desired.

2) Write Emission Maintenance Reminder (EMR) mileage into new PCM. Connect DRB-II to engine diagnostic connector. and erase faults. Recheck system for fault codes.

3) If fault codes reset, charging system still needs repair. Check all pertinent TECHNICAL SERVICE BULLETINS, and return to the TEST CH-1, BATTERY CONDITION CHECK.

## BENCH TESTING

NOTE: Alternators are not serviceable. Replace, if defective.

## OVERHAUL

Overhaul information is not available.

## TORQUE SPECIFICATIONS

TORQUE SPECIFICATIONS TABLE

---

Application	Ft.	Lbs	(N.m)
Alternator Mounting Bolts .....	28		(38)
Idler Pulley (Power Steering) .....	20		(27)

---