

G - AUTO TRANS DIAGNOSIS - 4.0L MODELS W/AW4

1993 Jeep Cherokee

AUTOMATIC TRANSMISSIONS
Aisin Warner 4 Electronic Diagnosis
1993-94 Cherokee

APPLICATION

NOTE: Transmission may also be referred to as AW-4.

APPLICATION

Model	Trans.
1993-94 Cherokee (1)	AW-4

(1) - Used on vehicles with 4.0L 6-cylinder engine only for 1993-94 model years.

NOTE: Vehicle body code may be required when diagnosing or repairing transmission, as body code may be used instead of vehicle model name. See BODY CODE DESIGNATION table.

BODY CODE DESIGNATION

Vehicle Model	Body Code
Cherokee	XJ

DESCRIPTION

The electronic control system for the AW-4 transmission controls transmission shift points and torque converter lock-up. Electronic control system consists of Transmission Control Module (TCM), valve body solenoids, throttle position sensor, speed sensor, neutral safety switch and brake switch.

NOTE: Transmission Control Module (TCM) may be referred to as Transmission Control Unit (TCU). Neutral safety switch may be referred to as park/neutral safety switch or gear select switch.

OPERATION

TRANSMISSION CONTROL MODULE (TCM)

The TCM determines shift points and torque converter lock-up based on input signals received from throttle position sensor, neutral safety switch, speed sensor and brake switch. The TCM controls transmission shift points and torque converter lock-up by operating electric solenoids mounted on the valve body.

The TCM contains a self-diagnostic system used for determining an electronic component failure. The TCM self-diagnostic system will store a diagnostic trouble code in the TCM memory if certain electronic problems exist. If electronic problem goes away, diagnostic trouble code will be erased from TCM memory after ignition has been cycled approximately 75 times.

NOTE: Diagnostic trouble code may be referred to as fault code.

Diagnostic trouble codes can be retrieved using a Diagnostic Readout Box-II (DRB-II). After repairing an electrical system problem, stored diagnostic trouble code must be cleared from TCM memory.

The TCM is located behind right side of instrument panel on Cherokee. See Fig. 1.

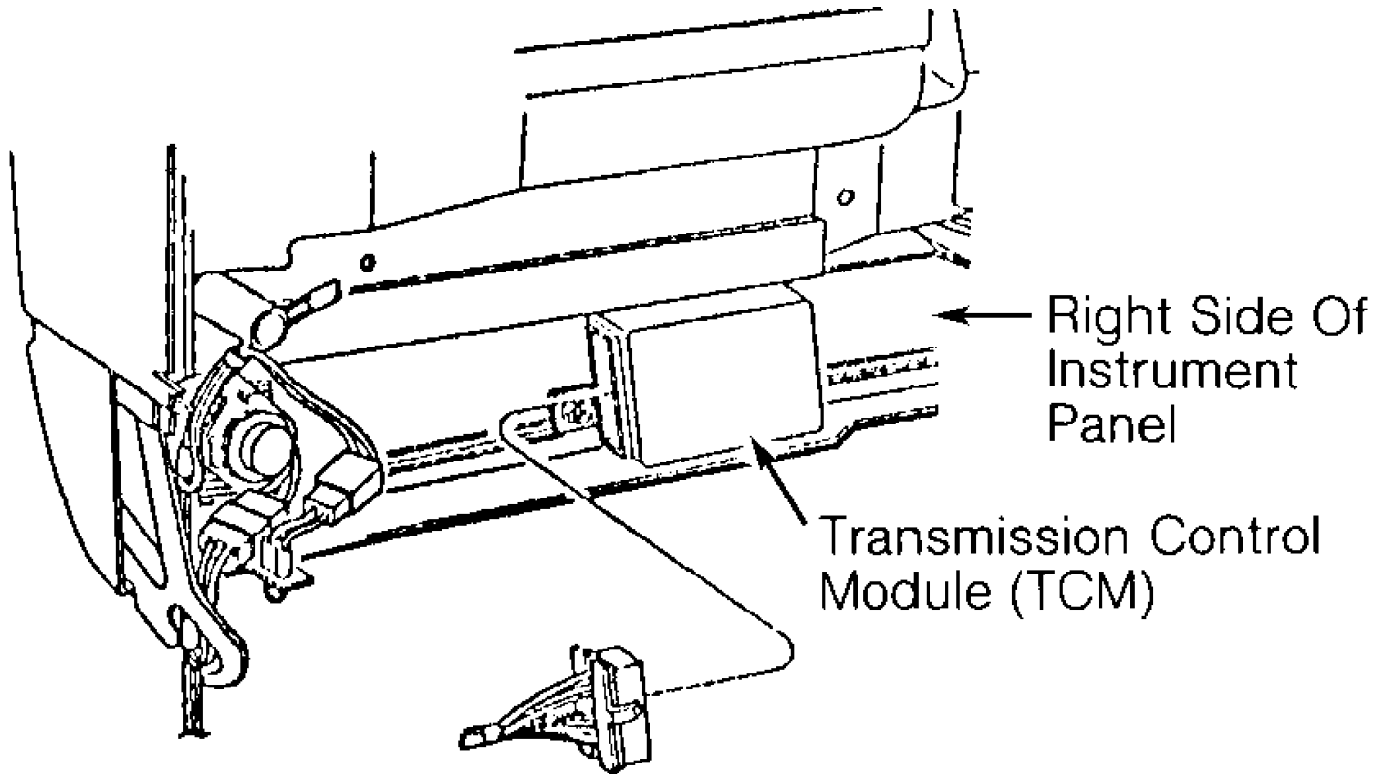

94F38401

Fig. 1: Transmission Control Module (TCM) I.D. (Cherokee)
Courtesy of Chrysler Corp.

VALVE BODY SOLENOIDS

Valve body solenoids, mounted on the valve body, are output devices controlled by signals received from the TCM. See Fig. 2. The No. 1 and 2 valve body solenoids control transmission shifts while the No. 3 valve body solenoid is used for torque converter lock-up.

When No. 1 and 2 valve body solenoids are energized, solenoid plunger moves from seat. This opens the drain port and releases line pressure. When either valve body solenoid is de-energized, plunger closes the drain port.

The No. 3 valve body solenoid operates in reverse. When No. 3 valve body solenoid is de-energized, solenoid plunger moves away from seat. This opens the drain port and releases line pressure. When No. 3 valve body solenoid is energized, the plunger closes the drain port.

NOTE: For valve body solenoid usage, see VALVE BODY SOLENOID APPLICATION table.

VALVE BODY SOLENOID APPLICATION (1)

Shifter Position	No. 1 Solenoid	No. 2 Solenoid
"D" (Drive)		
1st Gear	ON	OFF
2nd Gear	ON	ON
3rd Gear	OFF	ON
4th Gear	OFF	OFF
"3"		
1st Gear	ON	OFF
2nd Gear	ON	ON
3rd Gear	OFF	ON
"1-2"		
1st Gear	ON	OFF
2nd Gear	ON	ON
"R" (Reverse)	ON	OFF
"N" Or "P"	ON	OFF

(1) - Valve body contains 3 valve body solenoids. See Fig. 2. No. 1 and 2 valve body solenoids are used for controlling transmission shifts. No. 3 valve body solenoid is used for torque converter lock-up only.

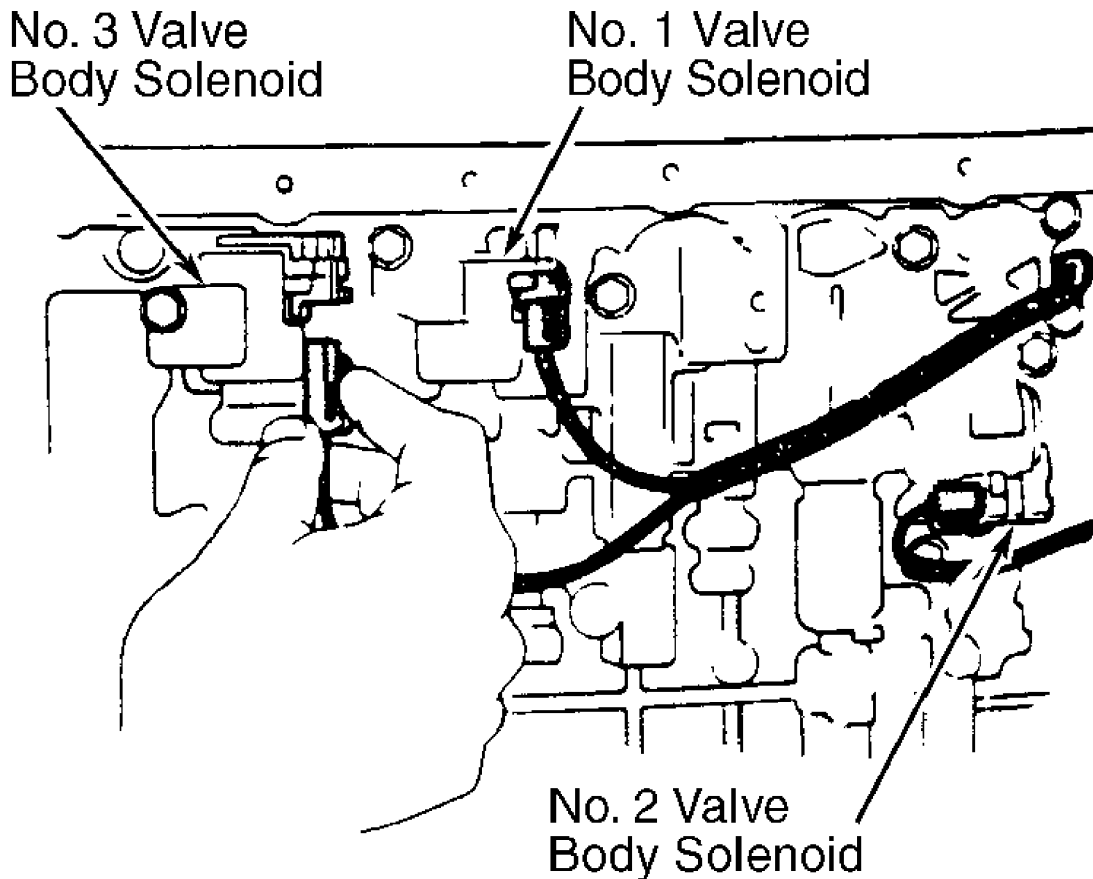

92F13511

Fig. 2: Identifying Valve Body Solenoids
 Courtesy of Chrysler Corp.

BRAKE SWITCH

Brake switch is an input device mounted above the brake pedal. When brake pedal is operated, brake switch delivers an input signal to the TCM. The TCM uses input signal for controlling No. 3 valve body solenoid for torque converter lock-up.

NEUTRAL SAFETY SWITCH

NOTE: Neutral safety switch may be referred to as park/neutral safety switch or gear select switch.

Neutral safety switch is an input device mounted on the transmission manual valve shaft. Neutral safety switch delivers an input signal to TCM, indicating transmission manual valve gear position.

SPEED SENSOR

Speed sensor, mounted in adapter housing or extension housing, is an input device consisting of speed sensor rotor and speed sensor. Speed sensor rotor is mounted on transmission output shaft. Input signal is delivered from speed sensor to TCM with each revolution of transmission output shaft. The TCM uses input signal for controlling transmission operation.

THROTTLE POSITION SENSOR (TPS)

The TPS, mounted on throttle body, determines throttle position and delivers an input signal to TCM. The TCM uses input signal for controlling transmission upshifts and torque converter lock-up.

SELF-DIAGNOSTIC SYSTEM

DIAGNOSTIC PROCEDURE

When performing vehicle diagnosis:

- * Ensure transmission fluid level is correct and fluid is neither contaminated nor aerated.
- * Ensure shift cable is properly adjusted. Refer to the appropriate TRANSMISSION SERVICING - A/T article in this section.
- * Ensure battery is fully charged.
- * Perform visual inspection, ensuring all electrical connections at transmission, TCM, throttle position sensor, neutral safety switch, speed sensor and brake switch are clean and properly installed.
- * Perform TEST 1A - VERIFICATION OF COMPLAINT under TROUBLE SHOOTING CHARTS in this article.
- * Repair diagnostic trouble codes in order displayed.
- * Always perform TEST 2A - VERIFICATION TEST after repair is completed. See TEST 2A - VERIFICATION TEST under TROUBLE SHOOTING CHARTS in this article.

RETRIEVING DIAGNOSTIC TROUBLE CODES

NOTE: Manufacturer recommends using Chrysler's Diagnostic Readout Box-II (DRB-II) with proper cartridge for system diagnosis. Other after-market scan tools may be used for system diagnosis. The following procedure is for DRB-II scan tool usage. Use manufacturer's instruction for operating the DRB-II scan tool. When retrieving diagnostic trouble codes

using DRB-II, you must first enter AW4 MENU and then retrieve diagnostic trouble codes.

NOTE: Ensure TEST 1A - VERIFICATION OF COMPLAINT is performed when trouble shooting the vehicle. This test checks for diagnostic trouble codes with vehicle stationary and during road test. See TEST 1A - VERIFICATION OF COMPLAINT under TROUBLE SHOOTING CHARTS.

NOTE: The DRB-II scan tool can be used in several different modes using manufacturer's instructions to activate system components and perform several tests on transmission. See DRB-II OPERATING MODES.

Entering AW4 MENU

1) Ensure ignition is off. Connect DRB-II to 6-pin transmission diagnostic connector. See Fig. 3. Transmission diagnostic connector is located on driver's side of instrument panel, above accelerator pedal.

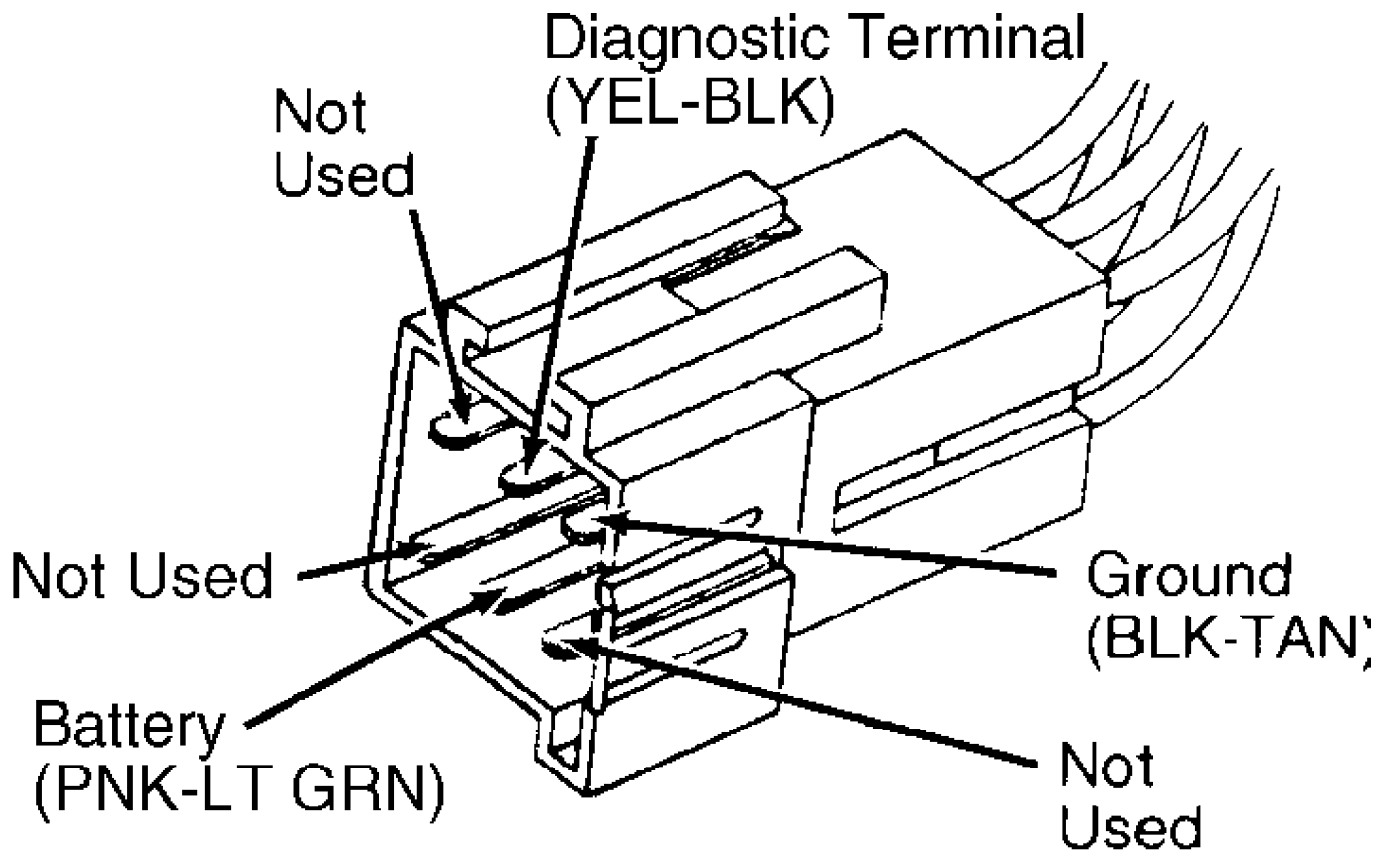

94F38427

Fig. 3: Diagnostic Connector & Terminals I.D. (Cherokee)
Courtesy of Chrysler Corp.

2) Turn ignition on. Copyright date and diagnostic program will be briefly displayed. If DRB-II displays an error message, proceed to DRB-II PROBLEMS & ERROR MESSAGES. The following are possible error messages that may appear.

- * CARTRIDGE ERROR
- * HIGH BATTERY

- * KEYPAD TEST FAILURE
- * LOW BATTERY
- * RAM TEST FAILURE

3) If no error messages appear, display will read as follows after a few seconds: 1) VEHICLES TESTED, 2) HOW TO USE, 3) CONFIGURE and 4) SELECT SYSTEM.

4) Select 4) SELECT SYSTEM to enter diagnostic system. Once in SELECT SYSTEM, select 2) TRANSMISSION to enter transmission. Display will read 1) EATX and 2) AW4.

5) Select 2) AW4. After a few seconds display will change to read AW4, VERSION 01. After a few seconds, display will read AW4 MENU, 1) SYSTEM TEST and 2) READ FAULTS. If DOWN ARROW is depressed 3 times, display will read as follows: 3) STATE DISPLAY, 4) ACTUATOR TESTS and 5) ADJUSTMENTS.

NOTE: The ACTUATOR TESTS and ADJUSTMENTS cannot be used when diagnosing the AW-4 transmission.

Retrieving Diagnostic Trouble Codes

1) Select 2) READ FAULTS from AW4 MENU. If no diagnostic trouble code exists, display will read as follows: AW4 FAULTS, NO FAULTS DETECTED.

2) If diagnostic trouble code exists, the following message will be displayed: 1 OF 3 FAULTS. This number will vary depending on number of diagnostic trouble codes stored in the TCM memory.

3) Diagnostic trouble code and message will be displayed. Press DOWN ARROW key to display next diagnostic trouble code. To identify diagnostic trouble code, see DIAGNOSTIC TROUBLE CODE IDENTIFICATION table.

NOTE: See TROUBLE SHOOTING CHARTS to diagnose faults indicated by trouble codes.

NOTE: Valve body solenoid diagnostic trouble code 700 may appear in a FAULT PRESENT or FAULT STORED status. Status will be displayed along with diagnostic trouble code. Diagnostic trouble code must be diagnosed depending on the status. See TEST 1A - VERIFICATION OF COMPLAINT under TROUBLE SHOOTING CHARTS.

DIAGNOSTIC TROUBLE CODE IDENTIFICATION

Trouble Code	Problem Area
700 (1)	Valve Body Solenoid
702	Speed Sensor
703	(2) Gear Select Switch
705	Throttle Position Sensor
706	Brake Switch
707	Wrong TCM Or TCU

(1) - Trouble code may apply to individual valve body solenoids. Valve body solenoid may be referred to as S1 for No. 1, S2 for No. 2 and S3 for No. 3.

(2) - Gear select switch is the same as the neutral safety switch.

CLEARING DIAGNOSTIC TROUBLE CODES

1) Once all diagnostic trouble codes have been obtained, diagnostic trouble code(s) can be erased from TCM memory by disconnecting electrical connector from TCM for at least 15 seconds.

CAUTION: DO NOT disconnect battery, as data stored in other vehicle control modules will be lost.

2) The TCM is located behind right side of instrument panel on Cherokee. See Fig. 1.

DRB-II OPERATING MODES

NOTE: The DRB-II can be operated in several different modes to perform various tests. Except for voltmeter/ohmmeter and HOW TO USE modes, all other operating modes are selected from AW4 MENU. See ENTERING AW4 MENU under RETRIEVING DIAGNOSTIC TROUBLE CODES.

VOLTMETER/OHMMETER MODE

To access voltmeter/ohmmeter mode, connect Red volt-ohmmeter test lead to Red port at top right corner of DRB-II. There are 2 different ports on top of DRB-II; ensure test lead is connected to proper port. Access voltmeter or ohmmeter mode using manufacturer's instructions.

NOTE: The DRB-II is grounded through transmission diagnostic connector and only one test lead is required. When diagnosing transmission, an external volt-ohmmeter may sometimes be required.

HOW TO USE MODE

1) This mode gives instructions on DRB-II usage. To enter this mode, see steps 1) through 4) of ENTERING AW4 MENU under RETRIEVING DIAGNOSTIC TROUBLE CODES. Select 2) HOW TO USE.

2) A series of screens will be displayed explaining DRB-II key usage for system diagnosing.

SYSTEM TEST MODE

NOTE: SYSTEM TEST mode consists of a stationary test and a road test. The SYSTEM TEST mode must be selected from AW4 MENU. Refer to ENTERING AW4 MENU under RETRIEVING DIAGNOSTIC TROUBLE CODES.

1) Stationary test monitors transmission system data, current valve body solenoid failures, switch failures, correct TCM application, calibration and operation. Road test checks all valve body solenoids and speed sensor.

2) Technician will be instructed to place shift lever in each gear position, starting by shifting into 1-2 position. Once transmission is in Park, brake pedal must be depressed to check brake switch.

3) After brake switch is checked, technician will be instructed to slowly depress throttle. DRB-II will display 7 asterisks (*****) corresponding to throttle position. While depressing accelerator, Throttle Position Sensor (TPS) sweeps through entire range of positions required by the TCM.

4) A corresponding asterisk will be cleared from DRB-II display as each throttle position is sensed by TCM. Several attempts may be required to clear all asterisks from the display, depending on how fast accelerator is depressed.

5) After throttle position is checked, technician will be instructed to drive the vehicle. The DRB-II will indicate if a

requested action is seen by the TCM. If technician is requested to perform a particular operation and TCM does not acknowledge the action, press ENTER key to continue testing.

6) The TCM will instruct technician to accelerate vehicle at light throttle to ensure transmission shifts through all gears, indicating proper valve body solenoid operation.

7) During road test, ensure vehicle can be accelerated slowly and evenly to allow transmission to enter all gear ranges without downshifting or braking. If a failure is sensed, a diagnostic trouble code will be displayed on DRB-II.

NOTE: If TCM senses a failure, control logic activates a specified valve body solenoid to obtain a certain gear depending on failure. Because transmission diagnostic trouble codes are displayed one at a time, multiple diagnostic trouble codes must be identified by retesting transmission.

STATE DISPLAY MODE

NOTE: STATE DISPLAY mode must be selected from AW4 MENU. See ENTERING AW4 MENU under RETRIEVING DIAGNOSTIC TROUBLE CODES. Select 3) STATE DISPLAY on DRB-II.

Module Information

When selecting module information option, the TCM version will be indicated by a 2-digit number. Information can be used to verify proper TCM application.

Sensor

1) When selecting sensor option, TPS and RPM indications will be shown. The TPS indicator will display a 7 segment bar graph, indicating TPS position and throttle plate angle.

2) A properly operating TPS should indicate 7 segments through full throttle travel. The RPM indicator will display transmission output shaft revolutions per minute.

Brake Switch Or Input/Output

Display indicates brake switch status, indicating whether brake pedal is applied or released. Display also indicates shift lever position, whether a valve body solenoid is on or off and present transmission operating gear.

DRB-II PROBLEMS & ERROR MESSAGES

CARTRIDGE ERROR

1) If CARTRIDGE ERROR message is displayed, disconnect DRB-II from transmission diagnostic connector. DO NOT touch keys on DRB-II keypad. Reconnect DRB-II to transmission diagnostic connector and note display.

2) If CARTRIDGE ERROR message is displayed, replace DRB-II cartridge and proceed with diagnostics. If KEYPAD TEST FAILURE message is displayed, replace DRB-II and proceed with diagnostics.

HIGH BATTERY

If HIGH BATTERY message is displayed, use external voltmeter to check battery voltage at battery terminals. If battery voltage is 11.7-13.0 volts, replace DRB-II. If battery voltage is not 11.7-13.0 volts, check charging system.

KEYPAD TEST FAILURE

1) If KEYPAD TEST FAILURE message is displayed, disconnect DRB-II from transmission diagnostic connector. DO NOT touch keys on DRB-II keypad. Reconnect DRB-II to transmission diagnostic connector and note display.

2) If KEYPAD TEST FAILURE message is not displayed, proceed with diagnostics. If KEYPAD TEST FAILURE message is displayed, replace DRB-II and proceed with diagnostics.

LOW BATTERY

If LOW BATTERY message is displayed, use external voltmeter to check battery voltage at battery terminals. If battery voltage is 11.7-13.0 volts, replace DRB-II. If battery voltage is not 11.7-13.0 volts, check charging system.

RAM TEST FAILURE

1) If RAM TEST FAILURE message is displayed, disconnect DRB-II from transmission diagnostic connector. DO NOT touch keys on DRB-II keypad. Reconnect DRB-II to transmission diagnostic connector and note display.

2) If RAM TEST FAILURE message is not displayed, proceed with diagnostics. If RAM TEST FAILURE message is displayed, replace DRB-II and proceed with diagnostics. If KEYPAD TEST FAILURE message is displayed, replace DRB-II and proceed with diagnostics.

COMPONENT TESTING

BRAKE SWITCH TEST

Brake switch is mounted above brake pedal. When brake pedal is operated, brake switch delivers an input signal to TCM. The TCM uses input signal for controlling No. 3 valve body solenoid for torque converter lock-up. No other information is available from manufacturer.

NOTE: For proper brake switch adjustment, see BRAKE SWITCH R & I under REMOVAL & INSTALLATION.

NEUTRAL SAFETY SWITCH TEST

NOTE: Neutral safety switch may be referred to as park/neutral or gear select switch. For proper neutral safety switch adjustment, see NEUTRAL SAFETY SWITCH R & I under REMOVAL & INSTALLATION.

Disconnect electrical connector. Note terminal identification. See Fig. 4. Using ohmmeter, check continuity between specified terminals in relation to shift lever position. See the NEUTRAL SAFETY SWITCH CONTINUITY SPECIFICATIONS table. Replace neutral safety switch if continuity is not as specified.

NEUTRAL SAFETY SWITCH CONTINUITY SPECIFICATIONS

Shift Lever Position	Continuity Between Terminals
Park	"B" & "C"
Reverse	"A" & "E"
Neutral	"B" & "C"
Drive	(1)
3	"A" & "G"

1-2 "A" & "H"

(1) - No continuity should exist between any terminals.

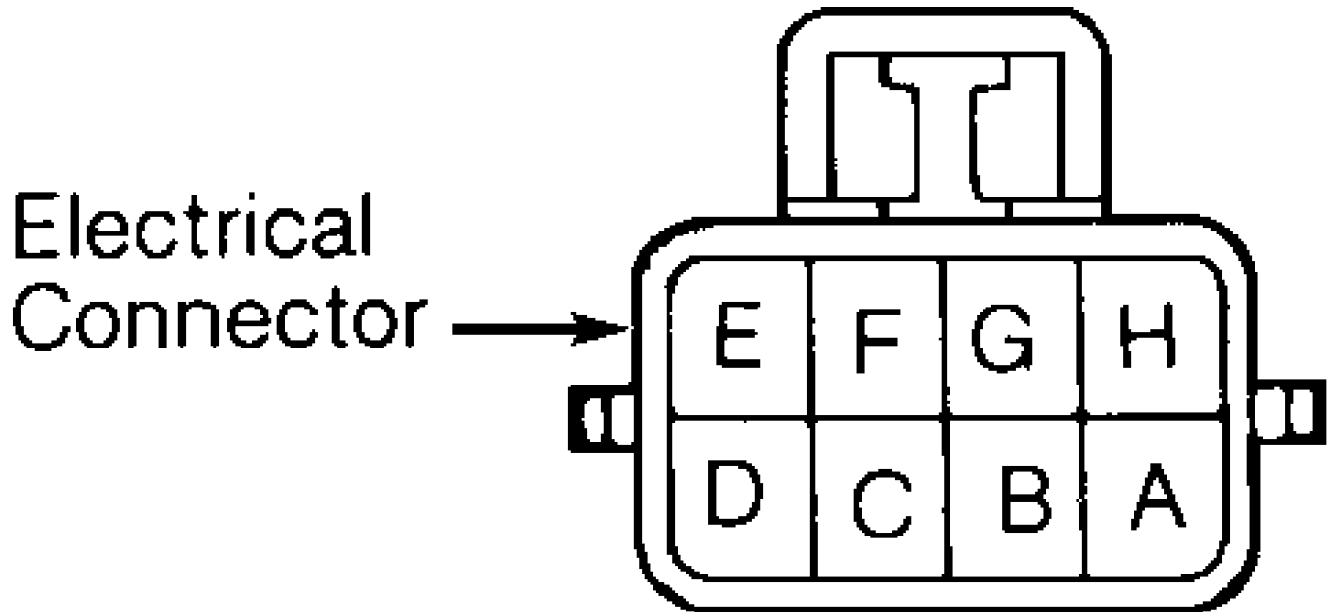

92H13513

Fig. 4: Identifying Neutral Safety Switch Terminals
Courtesy of Chrysler Corp.

SPEED SENSOR TEST

1) Disconnect electrical connector at speed sensor located on adapter housing or extension housing. Connect ohmmeter leads between speed sensor electrical terminals.

2) Rotate transmission output shaft and note ohmmeter reading. Ohmmeter needle should fluctuate to indicate speed sensor operation. Replace speed sensor if no reading is obtained.

THROTTLE POSITION SENSOR (TPS) TEST

NOTE: Digital voltmeter must be used to check TPS.

1) Note location of TPS electrical connector. See Fig. 5. Turn ignition on. Using digital voltmeter, check output voltage at center terminal with throttle plate closed (idle position) and wide open (full throttle).

2) With throttle plate closed (idle position), output voltage should be greater than 200 millivolts. With throttle plate wide open (full throttle), output voltage should be less than 4.8 volts.

3) Ensure output voltage gradually increases as throttle plate is moved from closed to wide open throttle. If no voltage exists, check for defective wiring circuits or connections. Replace TPS if defective.

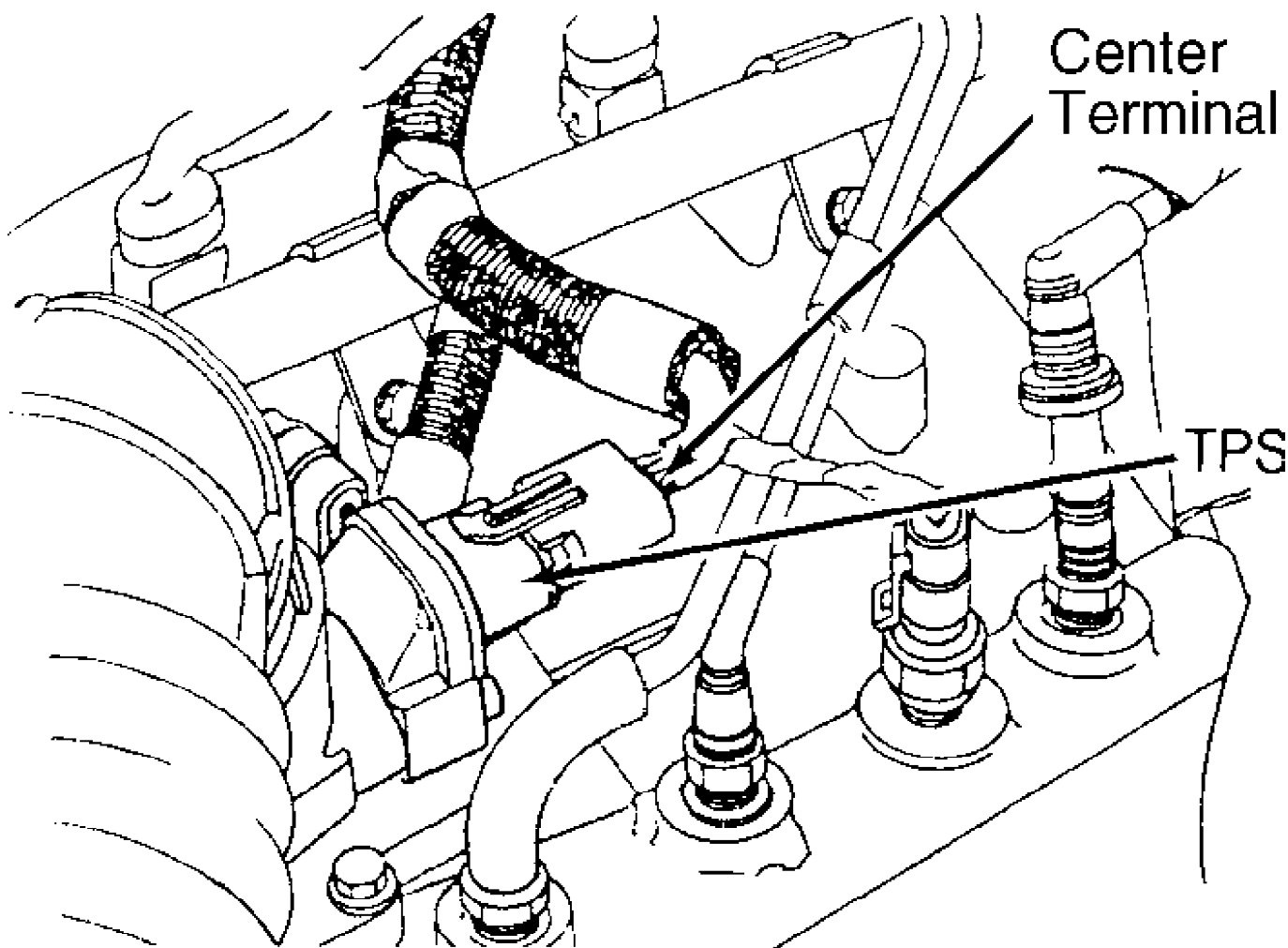

92113514

Fig. 5: Identifying TPS Electrical Connector
 Courtesy of Chrysler Corp.

VALVE BODY SOLENOID TEST

With oil pan removed, disconnect electrical connector from valve body solenoid. Using ohmmeter, check resistance between valve body solenoid electrical terminal and solenoid mounting bracket. Replace valve body solenoid if resistance is not 11-15 ohms.

TROUBLE SHOOTING CHARTS & CODE CHARTS

NOTE: Following trouble shooting charts and illustrations are courtesy of Chrysler Corp. Always start by performing TEST 1A - VERIFICATION OF COMPLAINT. When diagnosing transmission, it may be necessary to verify TCM connector terminals, circuits and function, See Fig. 6.

NOTE: When using trouble shooting charts, Transmission Control Module (TCM) may be referred to as Transmission Control Unit (TCU). Diagnostic trouble code may be referred to as fault code. Neutral safety switch may be referred to as park/neutral or gear select switch.

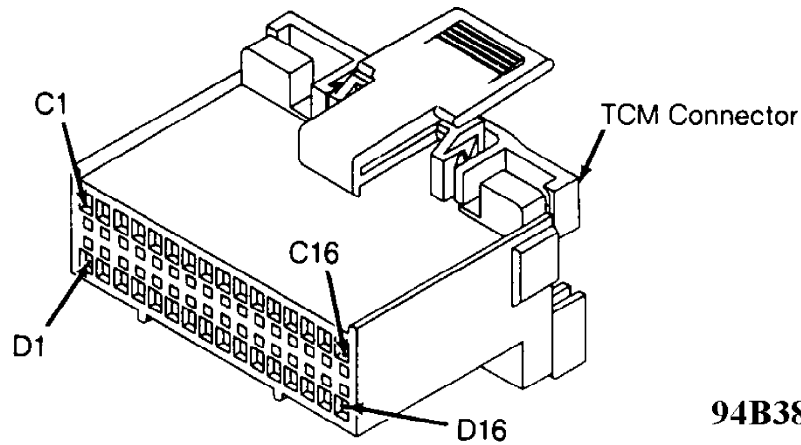

94B38431

CHEROKEE

CAV ... CIRCUIT	FUNCTION
C1-C2	Not Used
C3	505 TN/BK Trans Speed Sensor
C4	137 YL/BK Auto Trans Diagnostic
C5-C7	Not Used
C8	506 LG/BK Low (1-2) Input
C9	507 GY/BK Drive (3) Input
C10	K29 WT/PK Brake Input
C11	Not Used
C12-C13	Not Used
C14	508 WT/BK S3 Solenoid (Converter Lockup)
C15	509 VT/WT S2 Solenoid
C16	510 DB/WT S1 Solenoid
D1	Not Used
D2	K22 OR/DB Throttle Position Sensor
D3	K4 BK/LB TPS Signal Ground
D4-D6	Not Used
D7	Z12 BK/TN Power Ground
D8-D13	Not Used
D14	A14 RD Battery
D15	Not Used
D16	T17 YL Ignition (Run/On)

GRAND CHEROKEE

CAV... CIRCUIT	FUNCTION
C1-C2	Not Used
C3	T14 LG/WT Trans Speed Sensor
C4	D82 BK/YL Auto Trans Diagnostic
C5-C7	Not Used
C8	T25 LG Low (1-2) Input
C9	T50 DG Drive (3) Input
C10	L53 BR Brake Input
C11-C13	Not Used
C14	T20 LB/BR S3 Solenoid (Converter Lockup)
C15	T59 PK S2 Solenoid
C16	T60 BR/YL S1 Solenoid
D1	Not Used
D2	K22 OR/DB Throttle Position Sensor
D3	K4 BK/LB TPS Signal Ground
D4-D6	Not Used
D7	Z1 BK Power Ground
D8-D13	Not Used
D14	A14 RD/WT Battery
D15	Not Used
D16	F86 LB/RD Ignition (Run/On)

Fig. 6: TCM Connector Terminals I.D., Circuits & Functions
Courtesy of Chrysler Corp.

TEST 1A - VERIFICATION OF COMPLAINT

NOTE: ALWAYS start diagnosis with the most recent code.

- 1) Begin your testing of the transmission with a thorough visual inspection.
- 2) Connect the DRB-II to the transmission diagnostic

connector. See RETRIEVING DIAGNOSTIC TROUBLE CODES under SELF-DIAGNOSTIC SYSTEM for diagnostic connector location.

CAUTION: If the vehicle is in 3rd or OD position and feels like it is stuck in 3rd or jumping from 2-1 or 3-1, perform TEST 10A - TESTING FOR INTERMITTENT SPEED SENSORS.

3) With the DRB-II, perform SYSTEM TEST. See SYSTEM TEST MODE under DRB-II OPERATING MODES.

4) The DRB-II will instruct you to do some actions during the System Test. The DRB-II will then look for the action to happen and automatically go to the next test function. If you perform the required action and the DRB-II does not move to the next function, press ENTER. The DRB-II will continue the testing.

5) When the DRB-II states "VEHICLE DRIVE", the vehicle be must be driven at a speed above 4 miles per hour to ensure accurate testing of the vehicle speed sensor. Afterwards, the DRB-II will display any fault codes that may be present.

6) When the system test is complete, if there are any fault codes present, the DRB-II will automatically display the code(s).

7) There are two types of faults for the transmission solenoids. They are displayed as "FAULT STORED" and "FAULT PRESENT". Note that the tests are different in the chart below.

8) Perform the tests shown below in response to the indicated fault codes.

NOTE: ALWAYS start diagnosis with the most recent code.

CODE-TO-TEST MENU

CODE-TO-TEST MENU

Code:	Solenoid Affected:	Fault Status:	Perform:
None	None Affected	No Faults	TEST 2A
700	Solenoid No. 1	Fault Present	TEST 4A
700	Solenoid No. 1	Fault Stored	TEST 3A
700	Solenoid No. 2	Fault Present	TEST 4B
700	Solenoid No. 2	Fault Stored	TEST 3A
700	Solenoid No. 3	Fault Present	TEST 4C
700	Solenoid No. 3	Fault Stored	TEST 3A
702	Speed Sensor Fault	"	TEST 5A
703	Gear Select Fault	"	TEST 6A
705	TPS Fault	"	TEST 7A
708	Wrong TCU	"	TEST 9A

TEST 2A - VERIFICATION TEST

NOTE: Perform TEST 1A - VERIFICATION OF COMPLAINT before proceeding.

This test verifies the correct operation of the AW4

transmission. It must be performed after finding no faults using the DRB-II, and after a vehicle repair has been made.

- 1) Turn ignition key to "OFF".
- 2) Hold the MODE key and press the ATM key on the DRB-II at the same time to restart the DRB-II.
- 3) Turn ignition key to "ON".
- 4) Reconnect all previously disconnected connectors.
- 5) Verify that the AW4 transmission control unit is properly mounted.

6) Make sure the transmission fluid is at the proper level. Check the fluid with the transmission temperature hot, the vehicle on level ground, and the gear selector in neutral.

7) If any repairs have been made, test the vehicle as instructed in TEST 1A - VERIFICATION OF COMPLAINT., and read the faults using the DRB-II. If there are any fault messages present, repeat TEST 1A - VERIFICATION OF COMPLAINT.

TEST 3A - STORED DIAGNOSTIC TROUBLE CODES TEST

NOTE: Perform TEST 1A - VERIFICATION OF COMPLAINT before proceeding.

1) At this point, the Visual Inspection has been performed, a "FAULT STORED" code has been found and the vehicle has been test driven. The fault code is not "FAULT PRESENT", so it cannot be considered a CURRENT or HARD fault.

2) All solenoid circuits are in the same harness and a common ground wire is used for the solenoids. Use the following figures to identify the harness and connector to inspect. See Fig. 7 and 8. if all 3 solenoid faults are present, repair the Black wire (Cherokee) ground wire open condition.

3) Carefully inspect the entire suspected circuit. Pay particular attention to connectors, corrosion, accident damage, and improper or missing parts.

4) If any problems are found, make the appropriate repair. Then perform TEST 1A using the DRB-II.

5) Erase fault codes.

6) If no problems are found, perform the SYSTEM TEST using the DRB-II. Re-check for fault codes. If there are no fault codes, perform TEST 2A - VERIFICATION TEST. If fault code(s) return, perform TEST 1A - VERIFICATION OF COMPLAINT.

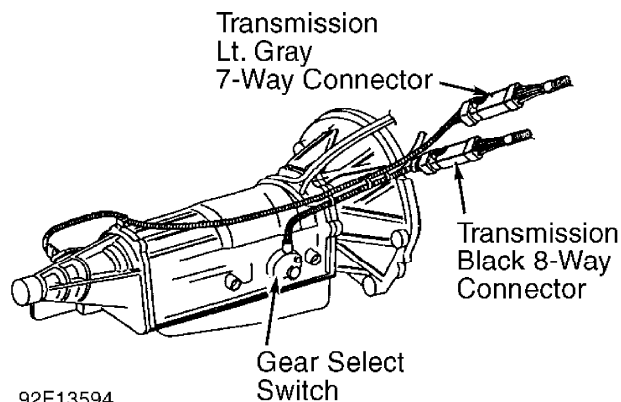

92F13594

Fig. 7: Test 3A - Location of 7-Way Connector

Transmission
 Lt. Gray
 7-Way Connector

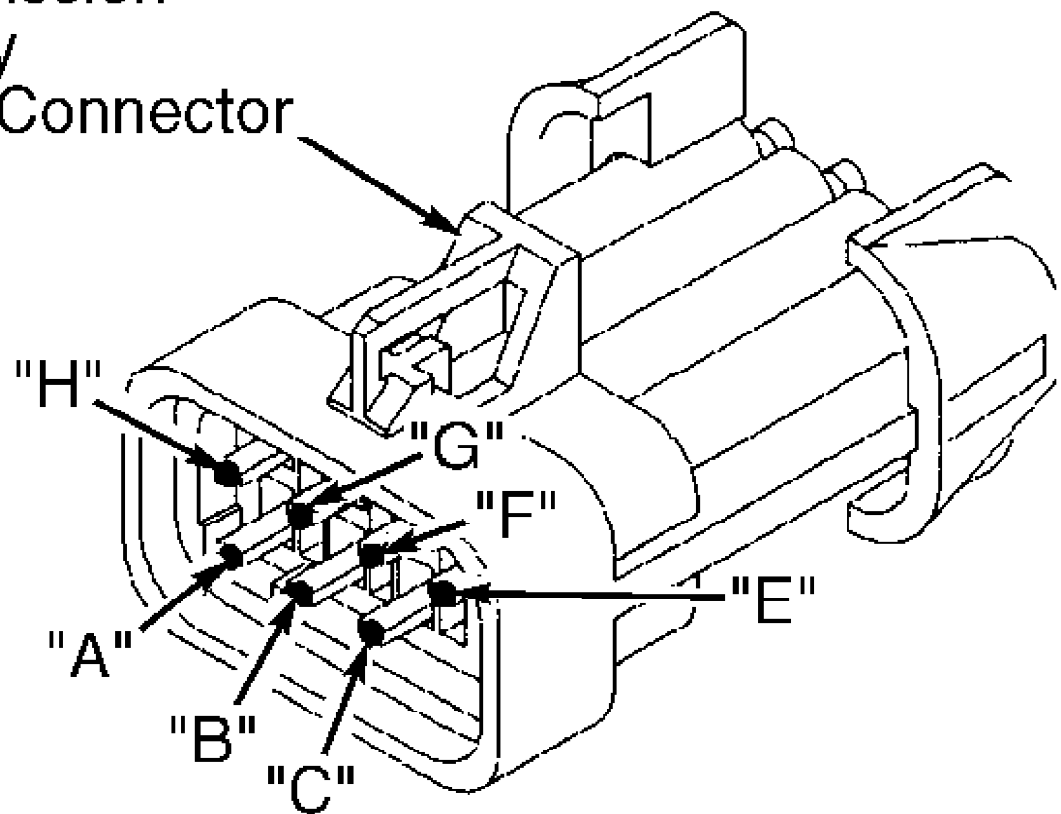

A	B	C	E	F	G	H
BK/YL	BK/TN	TN/WT	WT/BK	VT/WT	DB/WT	BK/RD

92G13595

Fig. 8: Test 3A - View of 7-Way Connector (Cherokee)

TEST 4A - CODE 700 - S1 SOLENOID CIRCUIT

Perform TEST 1A before proceeding.

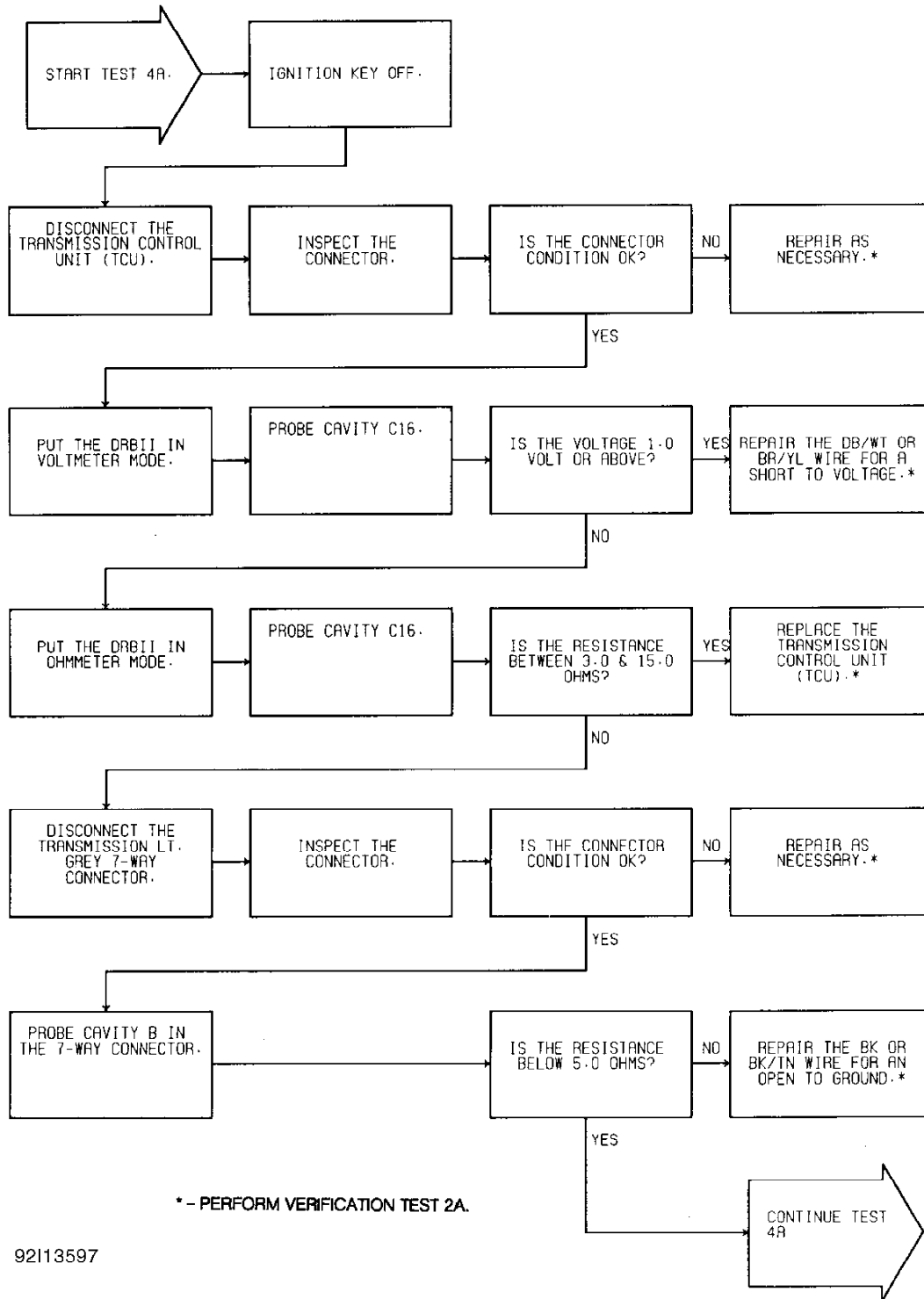

92113597

Fig. 9: Test 4A - Code 700, Flow Chart (1 of 2)

TCU TRANSMISSION SOLENOIDS (INSIDE TRANSMISSION)

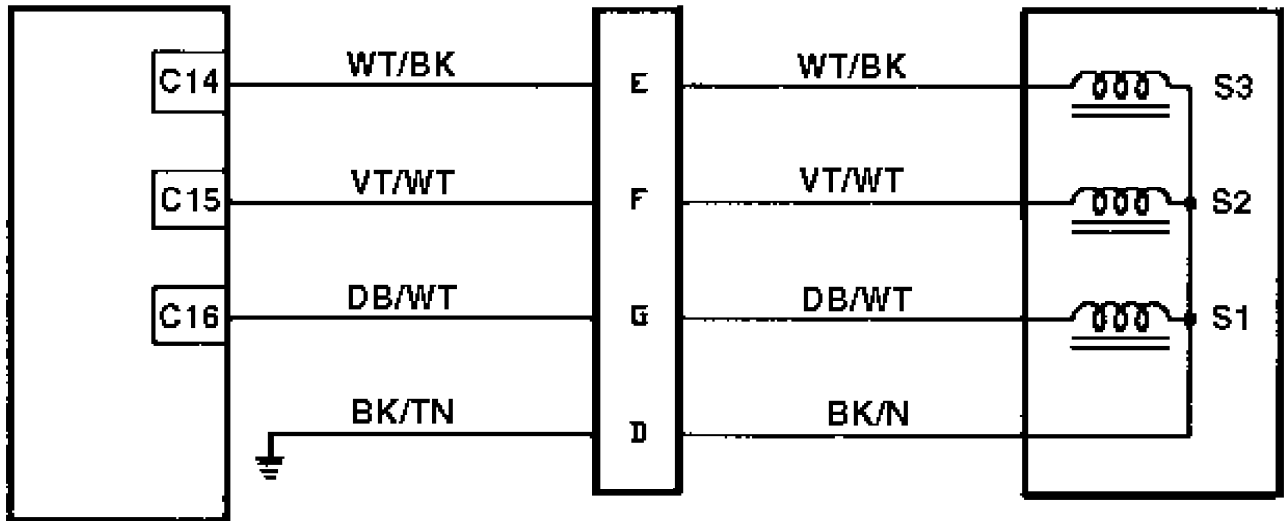

7-WAY
CONNECTOR

XJ BODIES

92J13598

Fig. 10: Test 4A - Code 700, Schematic (Cherokee)

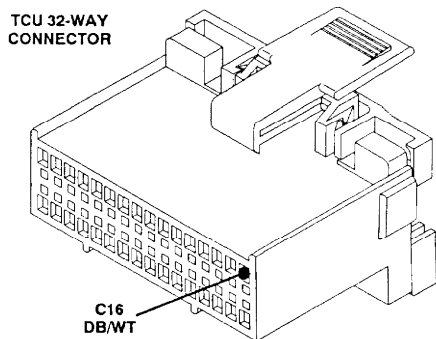

ZJ Body: BR/YL

92D13600

Fig. 11: Test 4A - Code 700, TCU 32-Way Connector (Cavity 16)

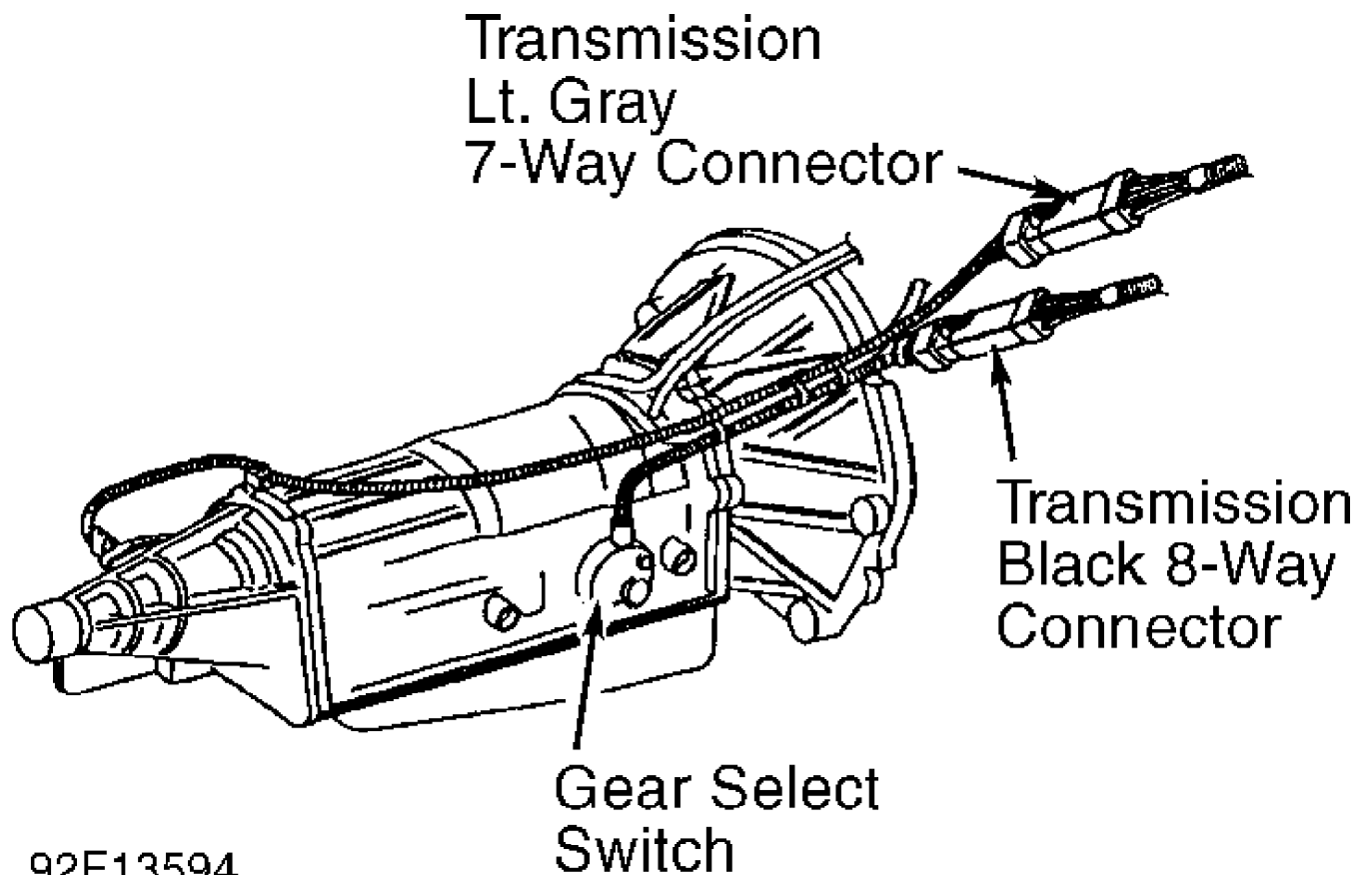

Fig. 12: Test 4A - Code 700, Location of 7-Way Connector

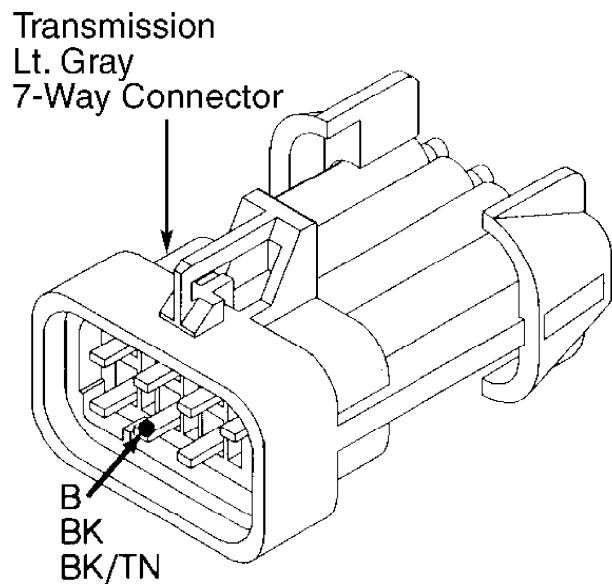
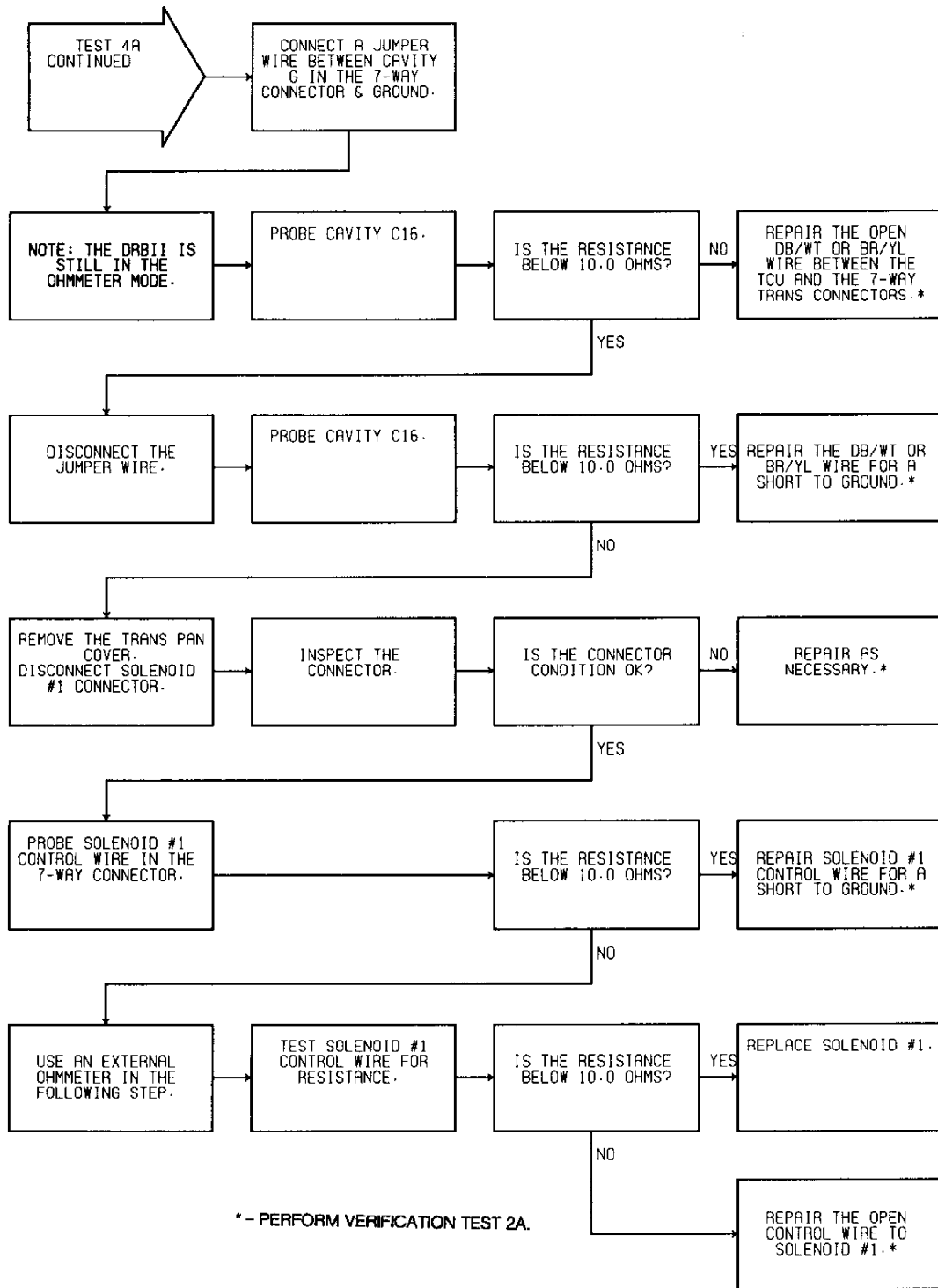

Fig. 13: Test 4A - Code 700, Location of Pin "B" (Ground)



NOTE: See TEST 4A (1 OF 2) for wiring diagram.

92F13602

Fig. 14: Test 4A - Code 700, Flow Chart (2 of 2)

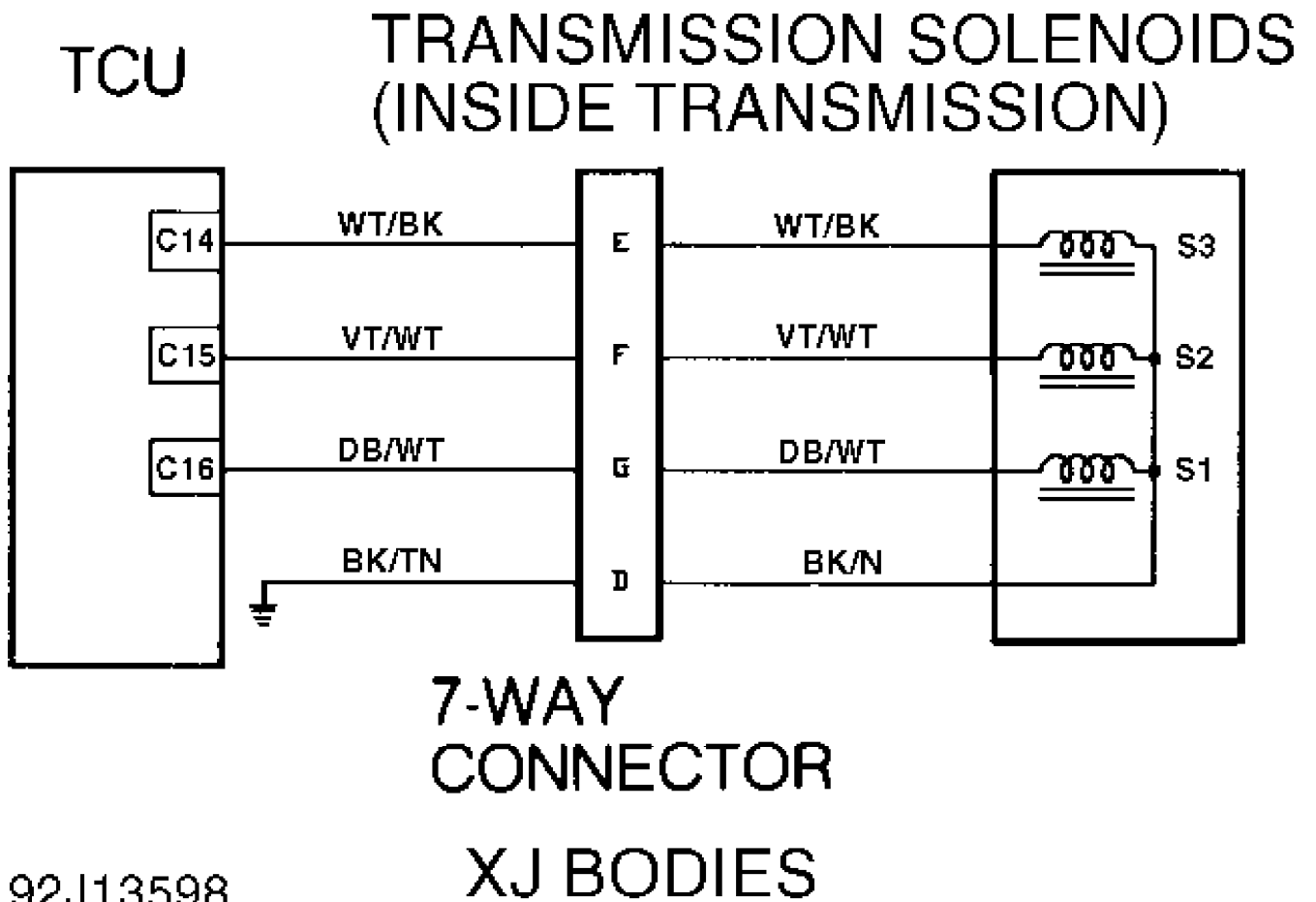

92J13598

Fig. 15: Test 4A - Code 700, Schematic (Cherokee)

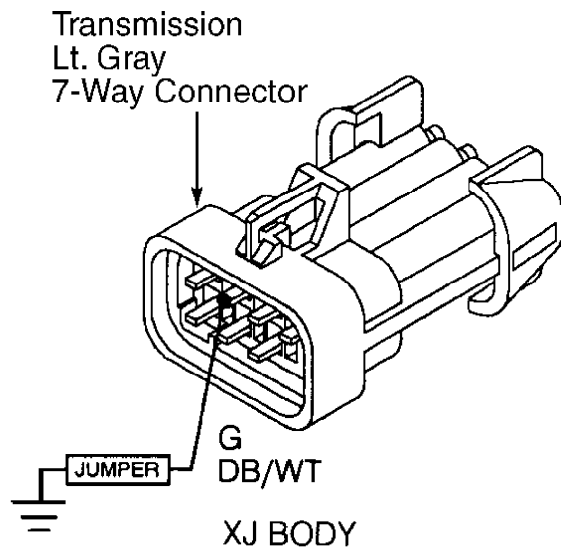

92G13603

Fig. 16: Test 4A - 7-Way Connector Cavity "G" (Cherokee)

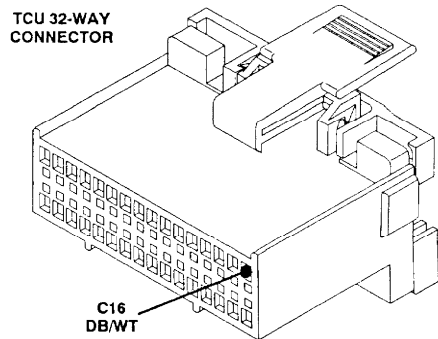

92D13600

ZJ Body: BR/YL

Fig. 17: Test 4A - Code 700, TCU 32-Way Connector (Cavity 16)

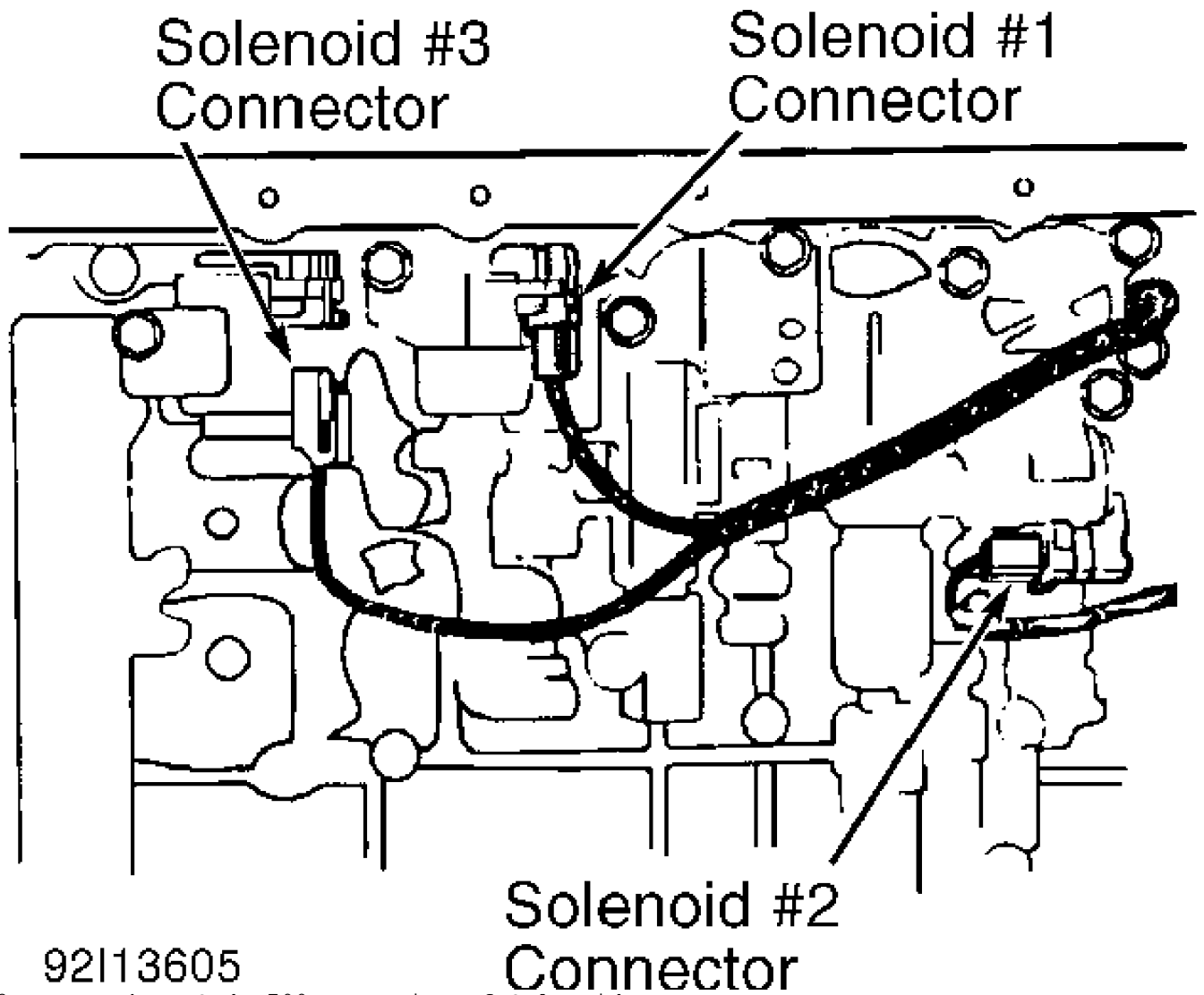
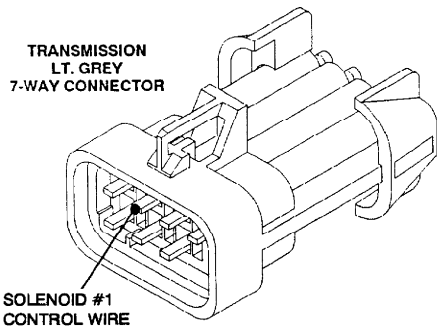

Fig. 18: Test 4A - Code 700, Location of Solenoids



CAV	MJ/XJ	ZJ
G	DB/WT	BR/YL

Fig. 19: Test 4A - Code 700, Solenoid No. 1 Wire (Cavity "G") ^{92J13606}

Transmission
Lt. Gray
7-Way Connector

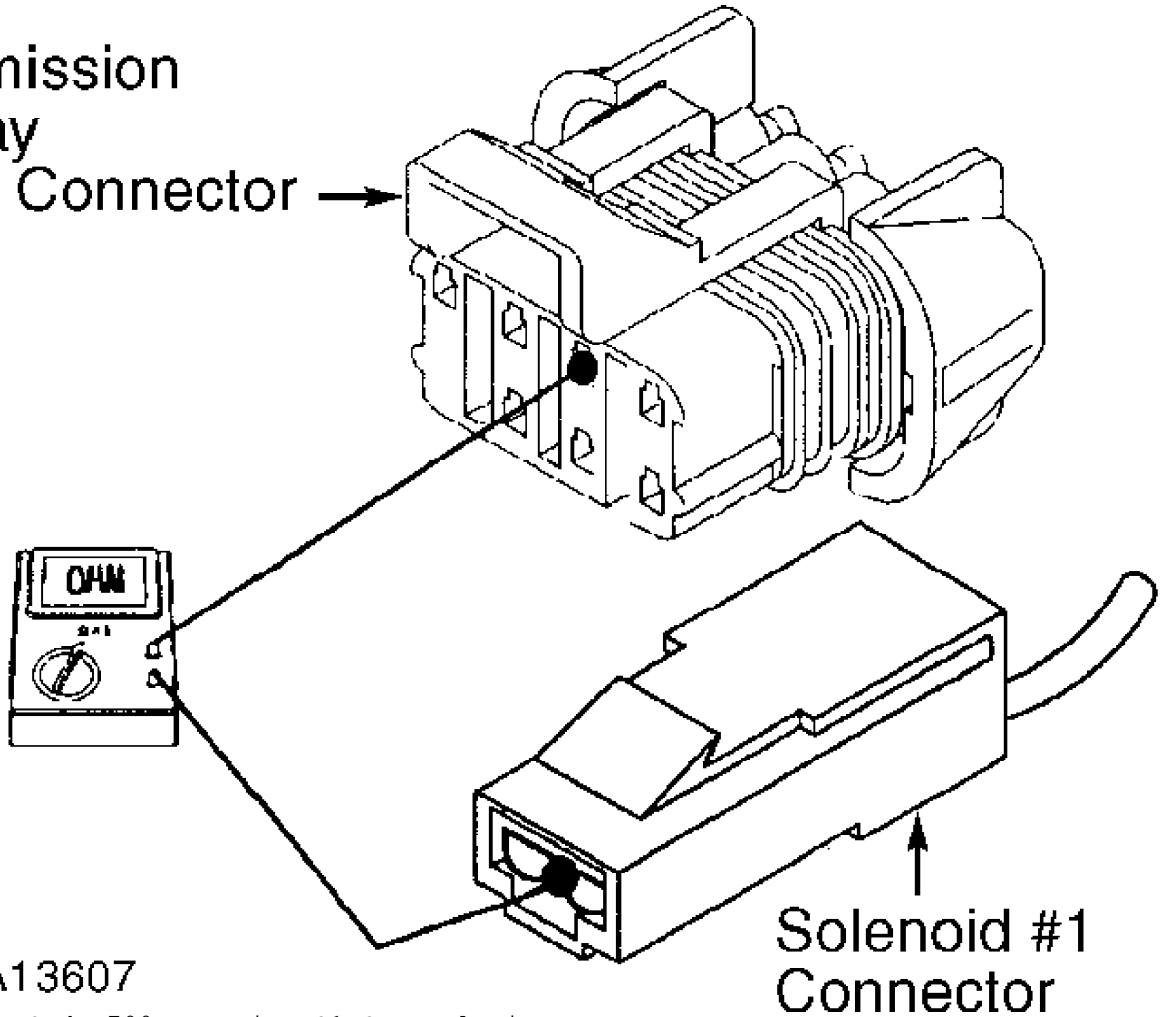
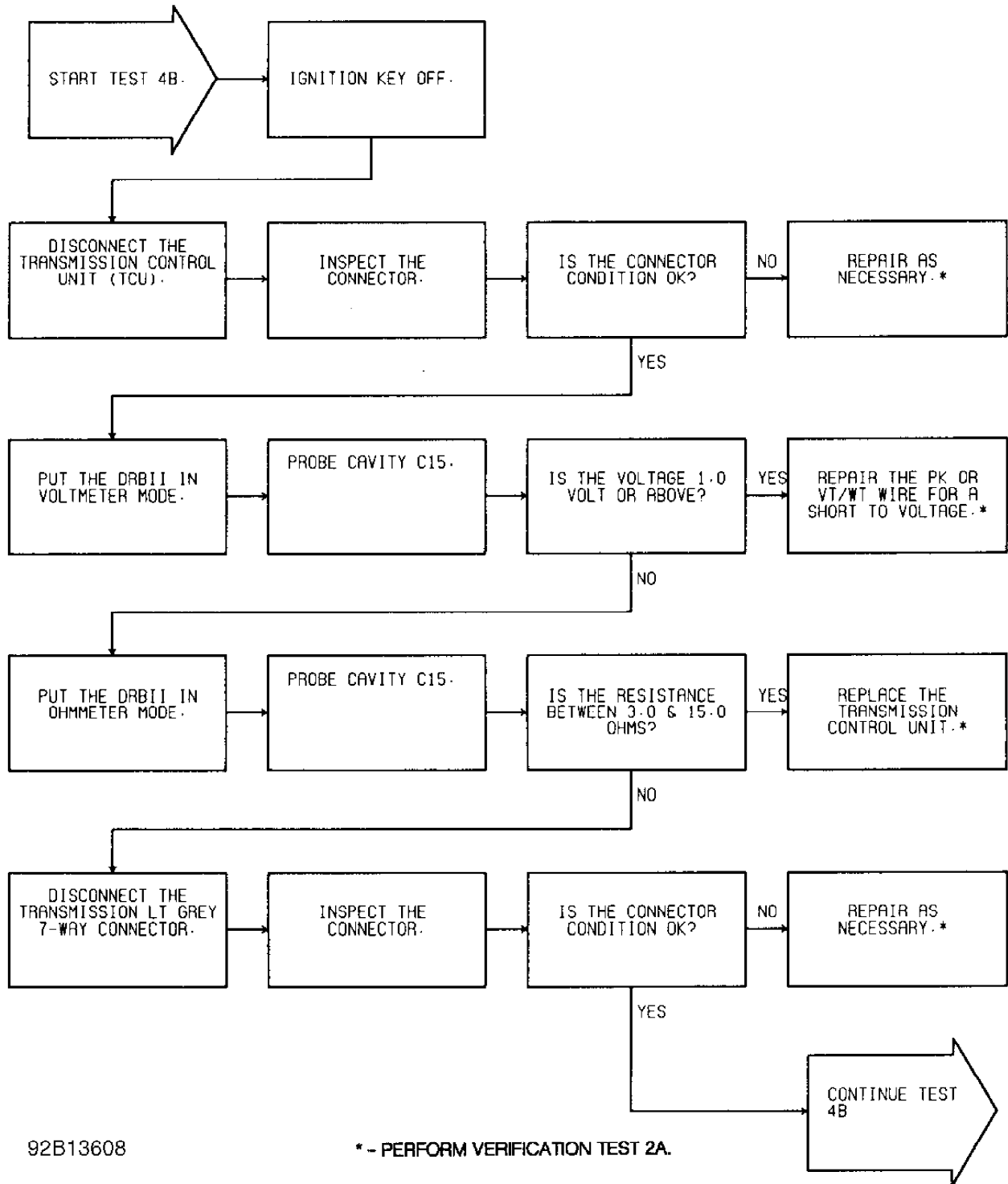

Fig. 20: Test 4A - Code 700, Testing S1 Control Wire

TEST 4B - CODE 700 - S2 SOLENOID CIRCUIT

Perform TEST 4A before proceeding.



92B13608

* - PERFORM VERIFICATION TEST 2A.

Fig. 21: Test 4B - Code 700, Flow Chart (1 of 2)

TCU

TRANSMISSION SOLENOIDS (INSIDE TRANSMISSION)

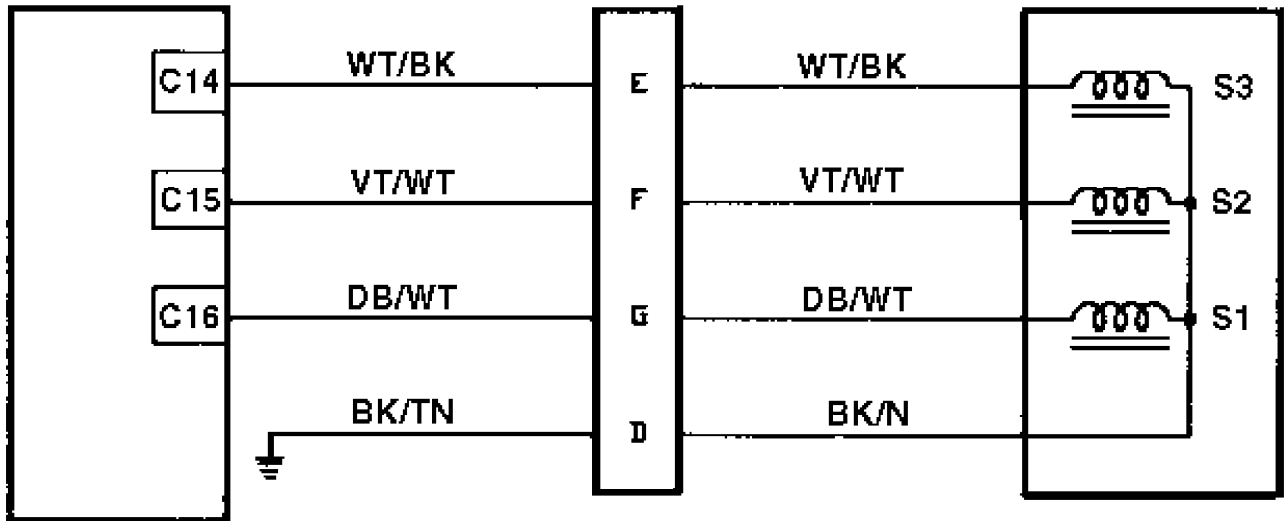

7-WAY
CONNECTOR

XJ BODIES

92J13598

Fig. 22: Test 4B - Code 700, Schematic (Cherokee)

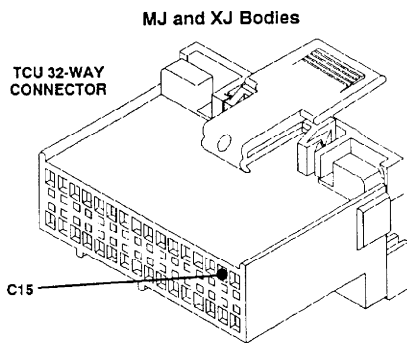

CAV	MJ/XJ	ZJ
C15	VT/WT	PK

92C13609

Fig. 23: Test 4B - Code 700, TCU 32-Way Connector (Cavity 15)

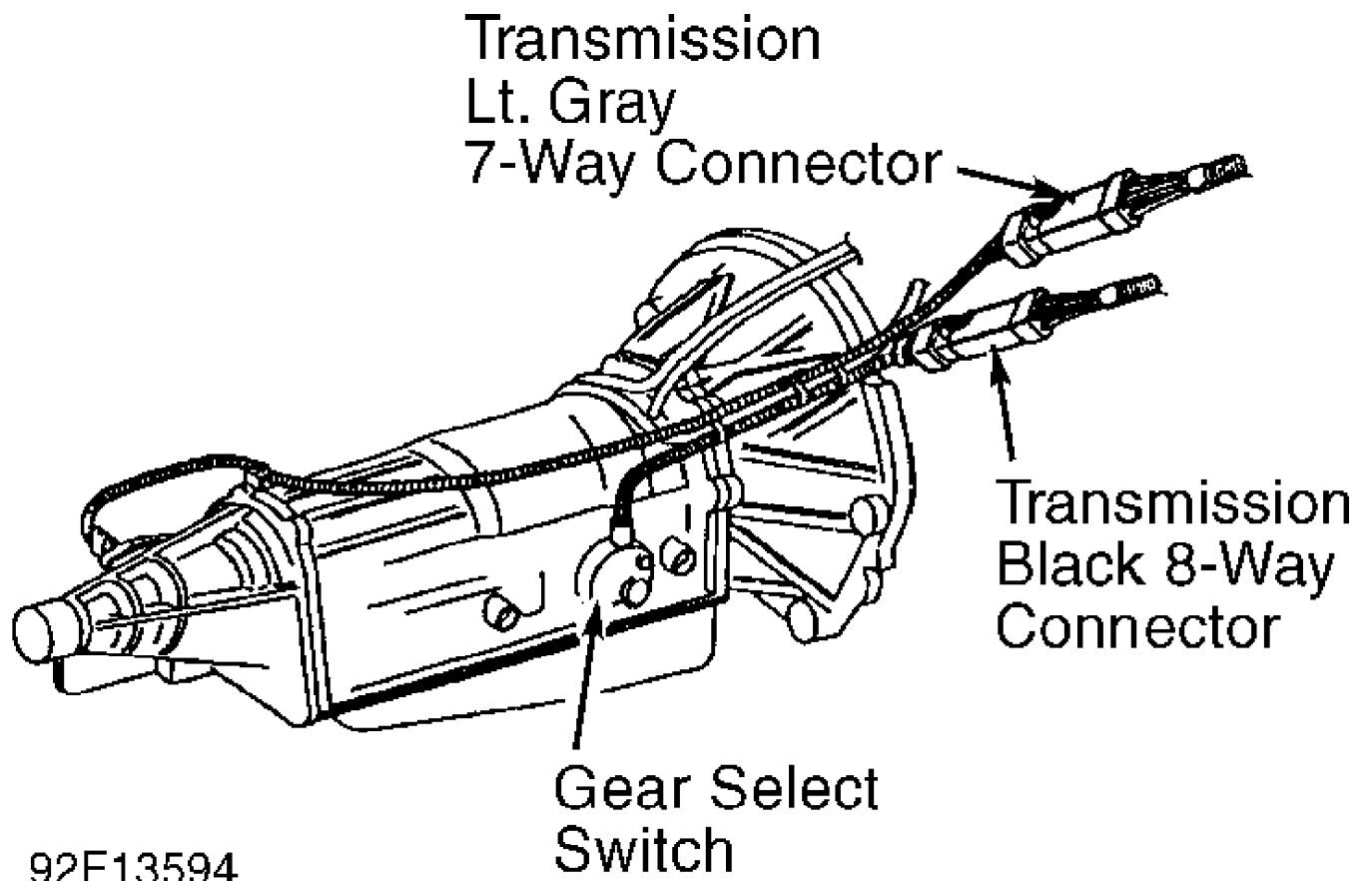

92F13594

Fig. 24: Test 4B - Code 700, Location of 7-Way Connector

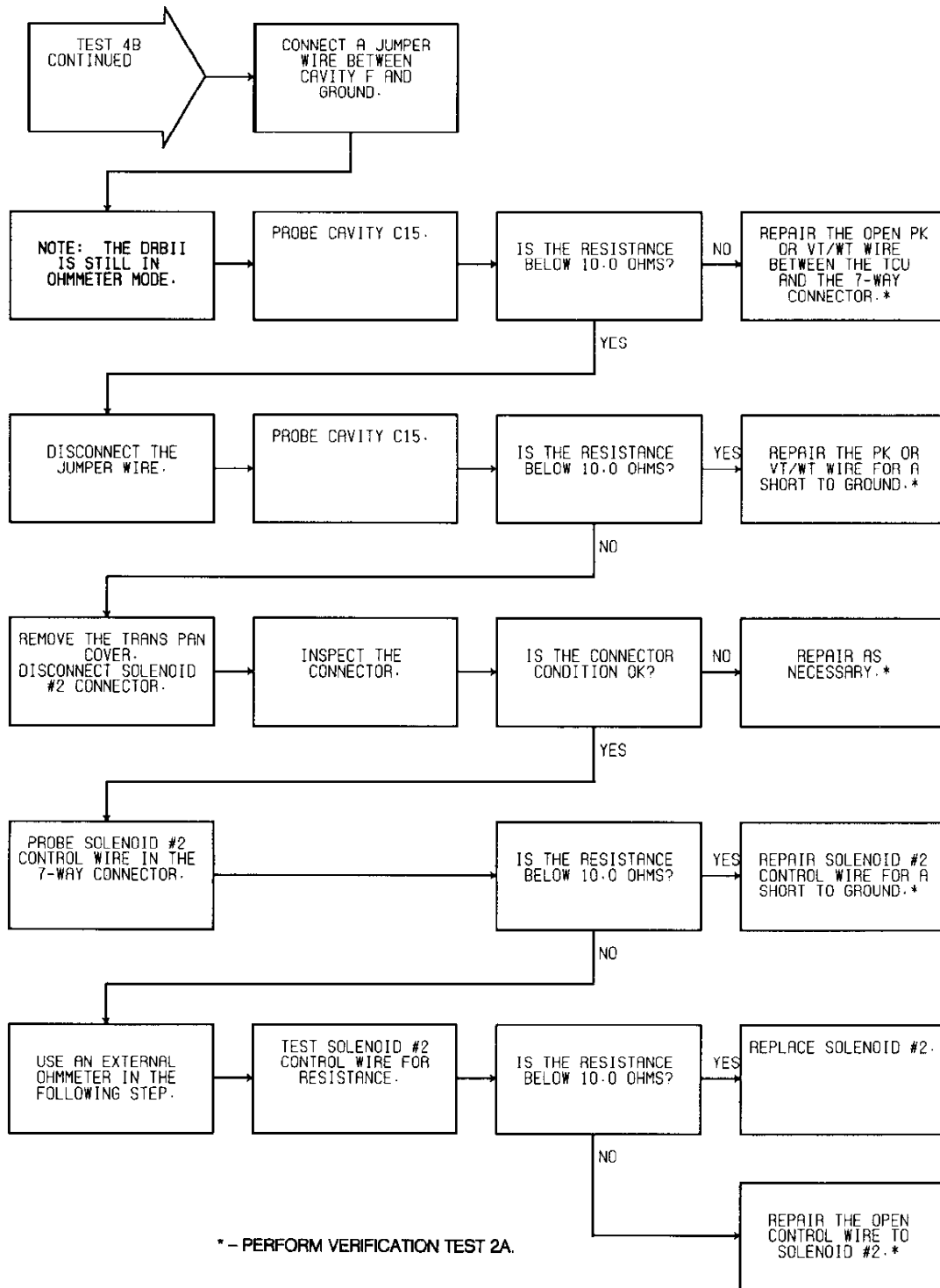

NOTE: See TEST 4B (1 OF 2) for wiring diagram.

92F13610

Fig. 25: Test 4B - Code 700, Flow Chart (2 of 2)

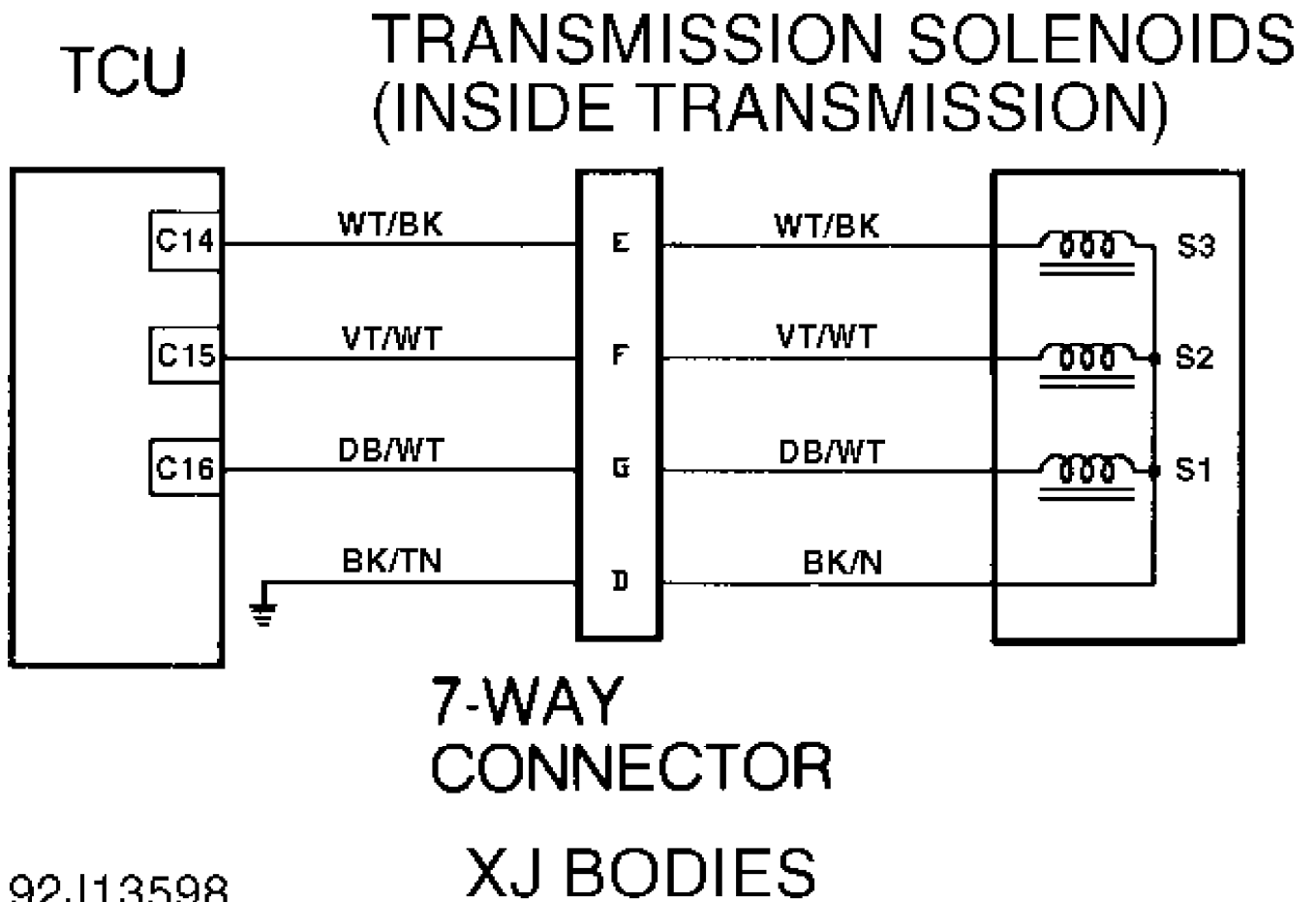

92J13598

Fig. 26: Test 4B - Code 700, Schematic (Cherokee)

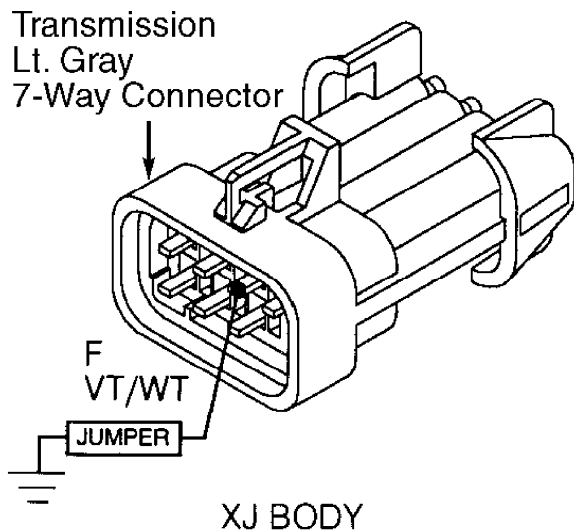

92G13611

Fig. 27: Test 4B - 7-Way Connector Cavity "F" (Cherokee)

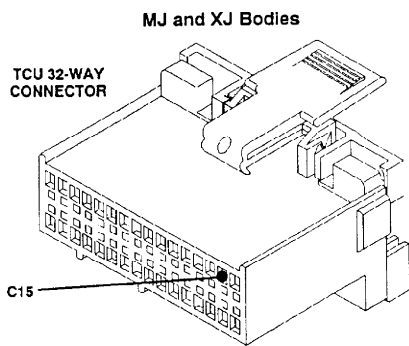

CAV	MJ/XJ	ZJ
C15	VT/WT	PK

92C13609

Fig. 28: Test 4B - Code 700, TCU 32-Way Connector (Cavity 15)

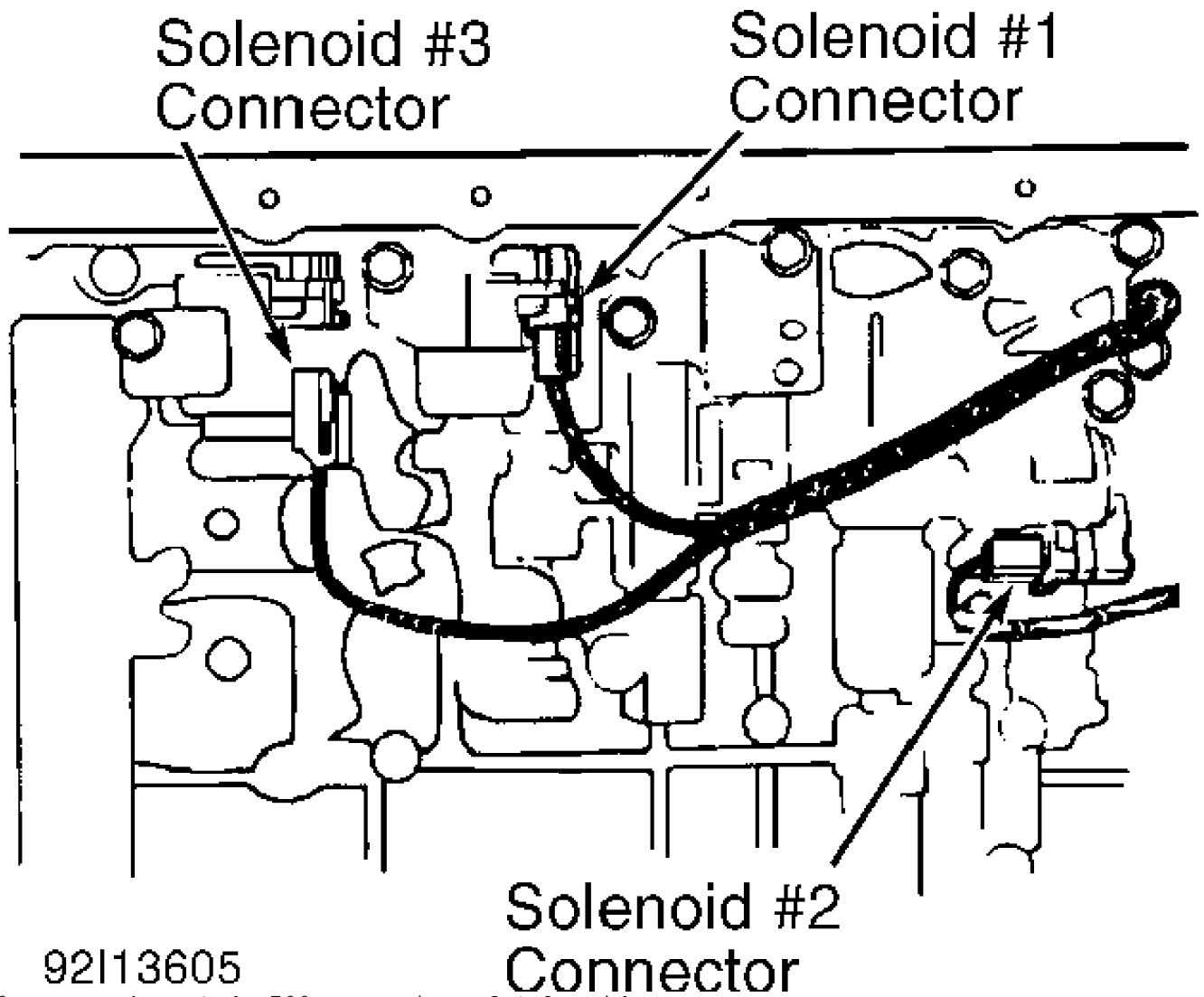
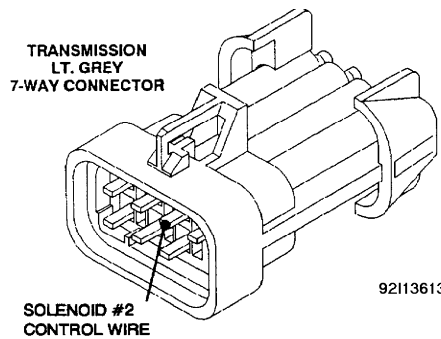

Fig. 29: Test 4B - Code 700, Location of Solenoids



CAV	MJ/XJ	ZJ
F	VT/WT	PK

Fig. 30: Test 4B - Code 700, Solenoid No. 1 Wire (Cavity "F")

Transmission
Lt. Gray
7-Way Connector

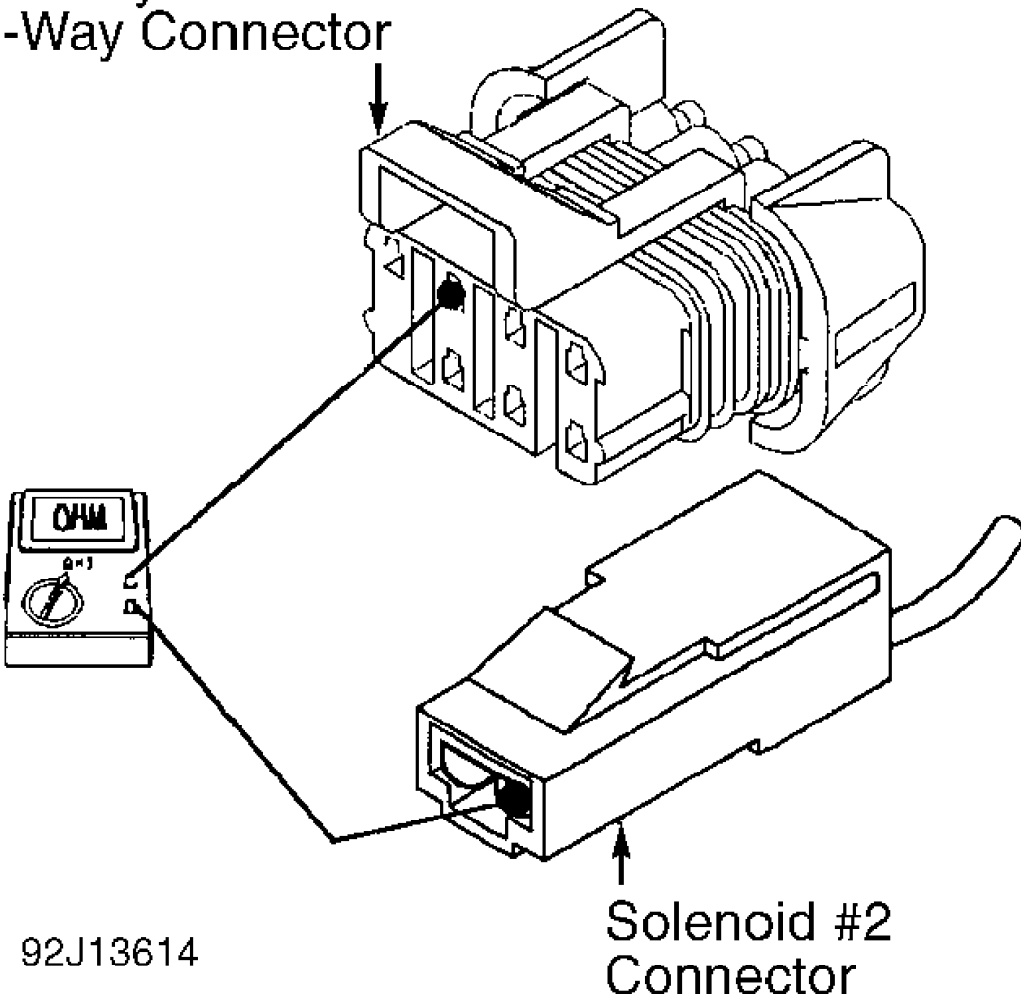
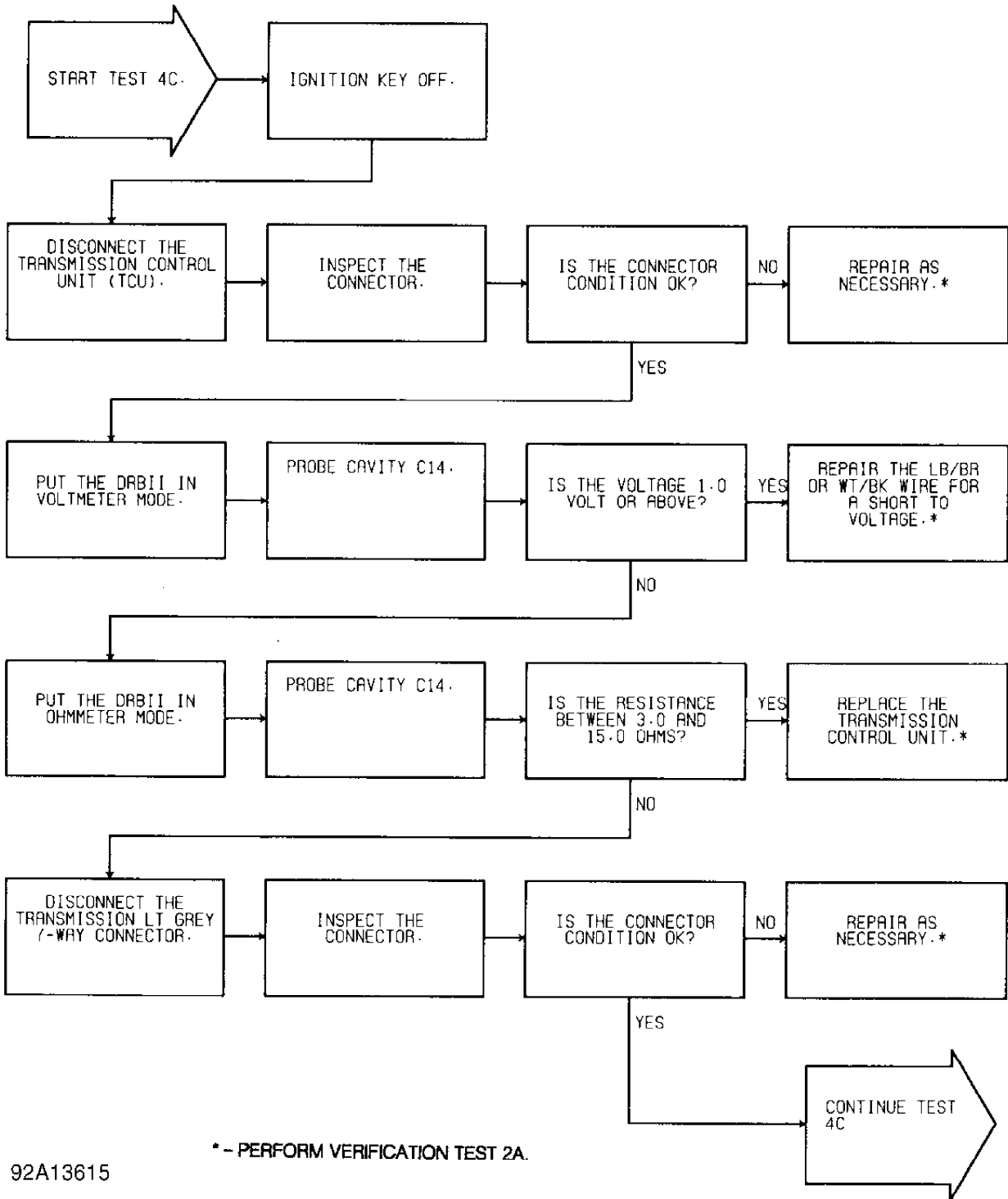

Fig. 31: Test 4B - Code 700, Testing S2 Control Wire

TEST 4C - CODE 700 - S3 SOLENOID CIRCUIT

Perform TEST 4A before proceeding.



92A13615

Fig. 32: Test 4C - Code 700, Flow Chart (1 of 2)

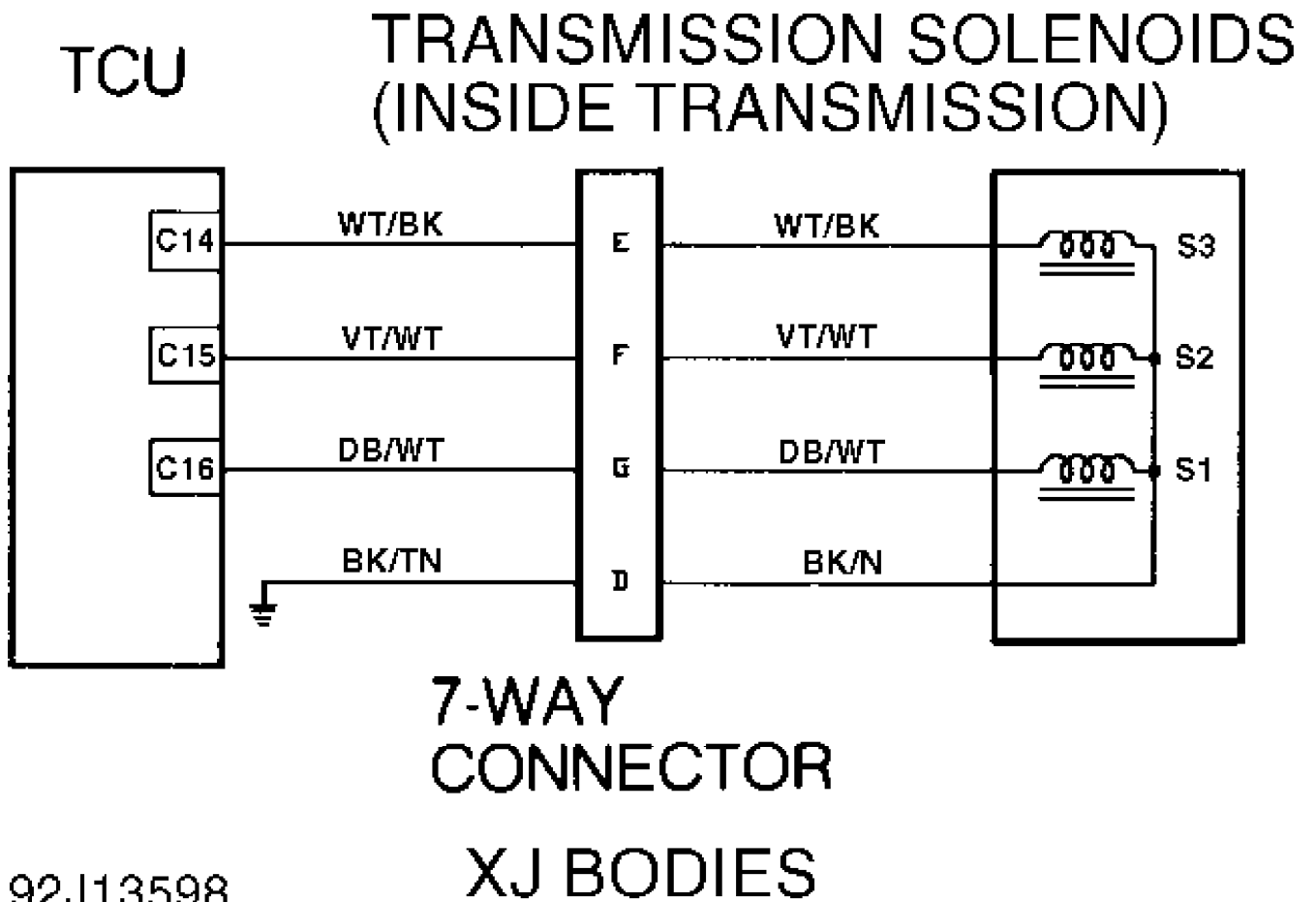

92J13598

Fig. 33: Test 4C - Code 700, Schematic (Cherokee)

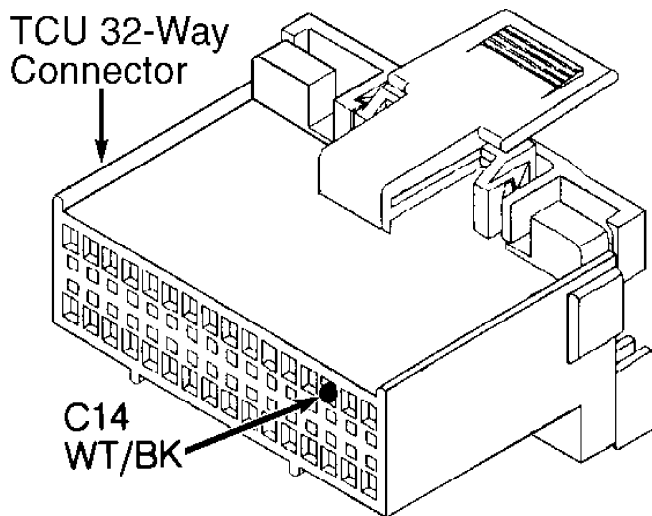

92B13616

Fig. 34: Test 4C - TCU 32-Way Connector (Cavity 14, Cherokee)

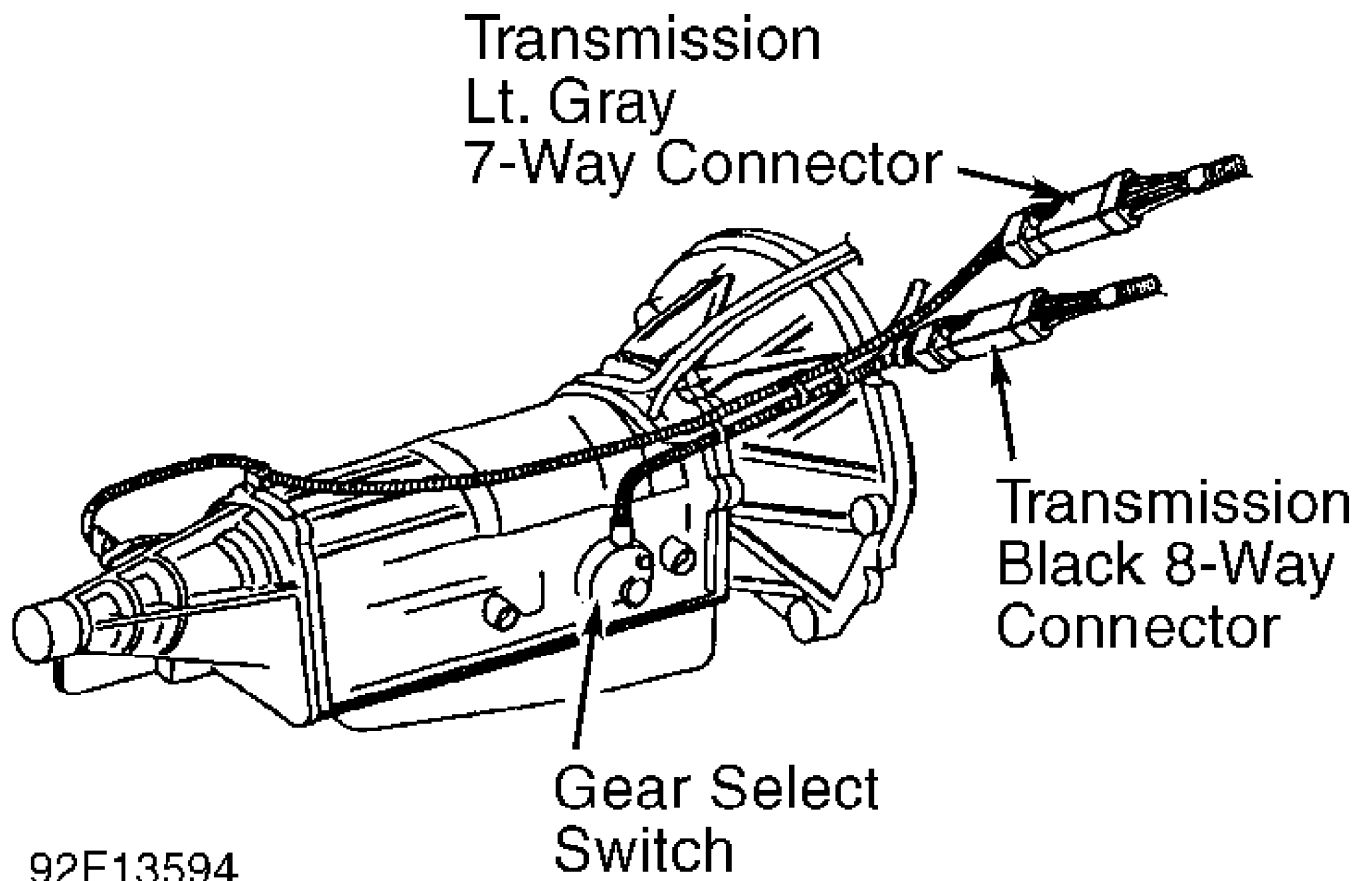

92F13594

Fig. 35: Test 4C - Code 700, Location of 7-Way Connector

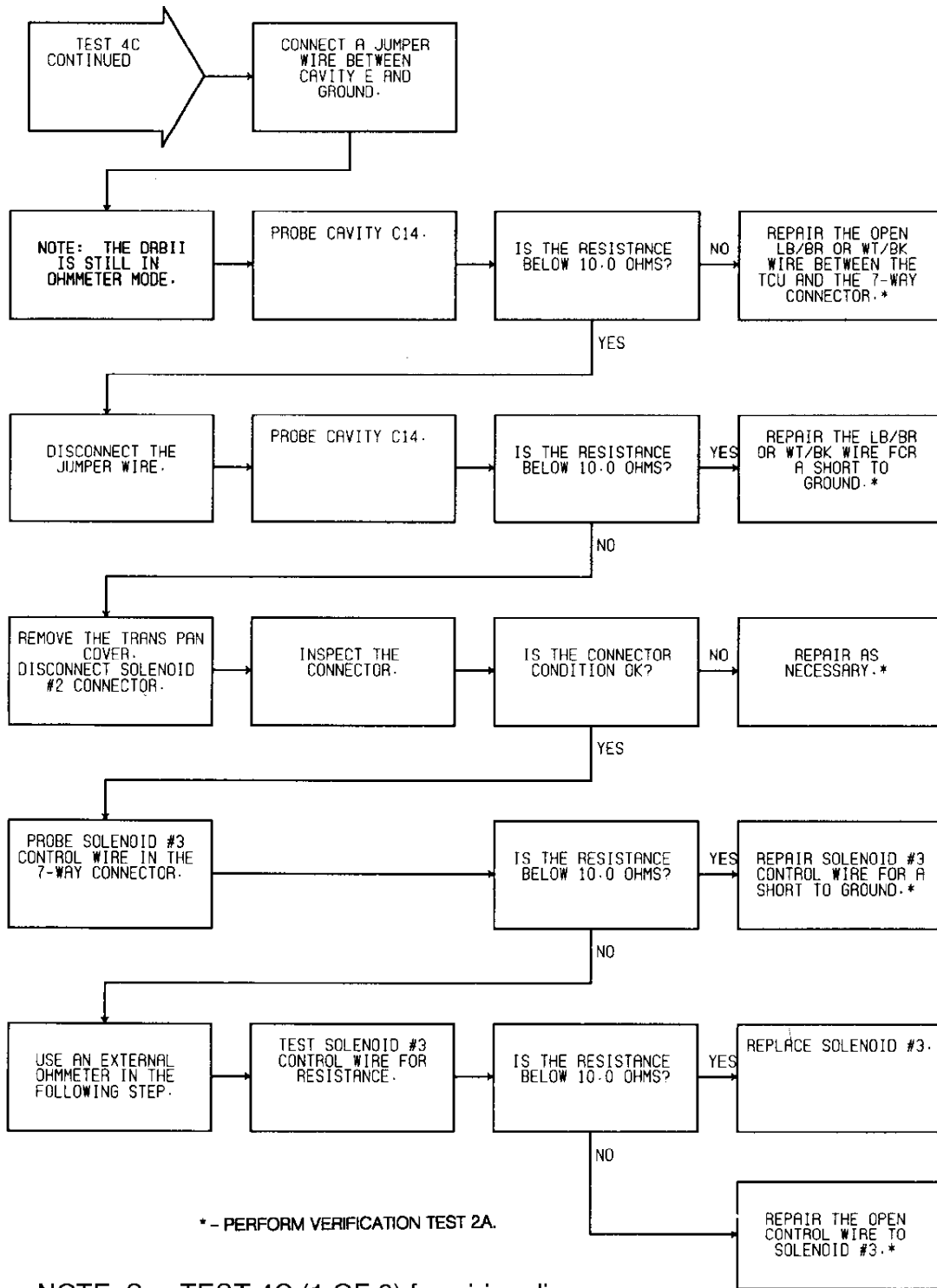

NOTE: See TEST 4C (1 OF 2) for wiring diagram.

92D13618
Fig. 36: Test 4C - Code 700, Flow Chart (2 of 2)

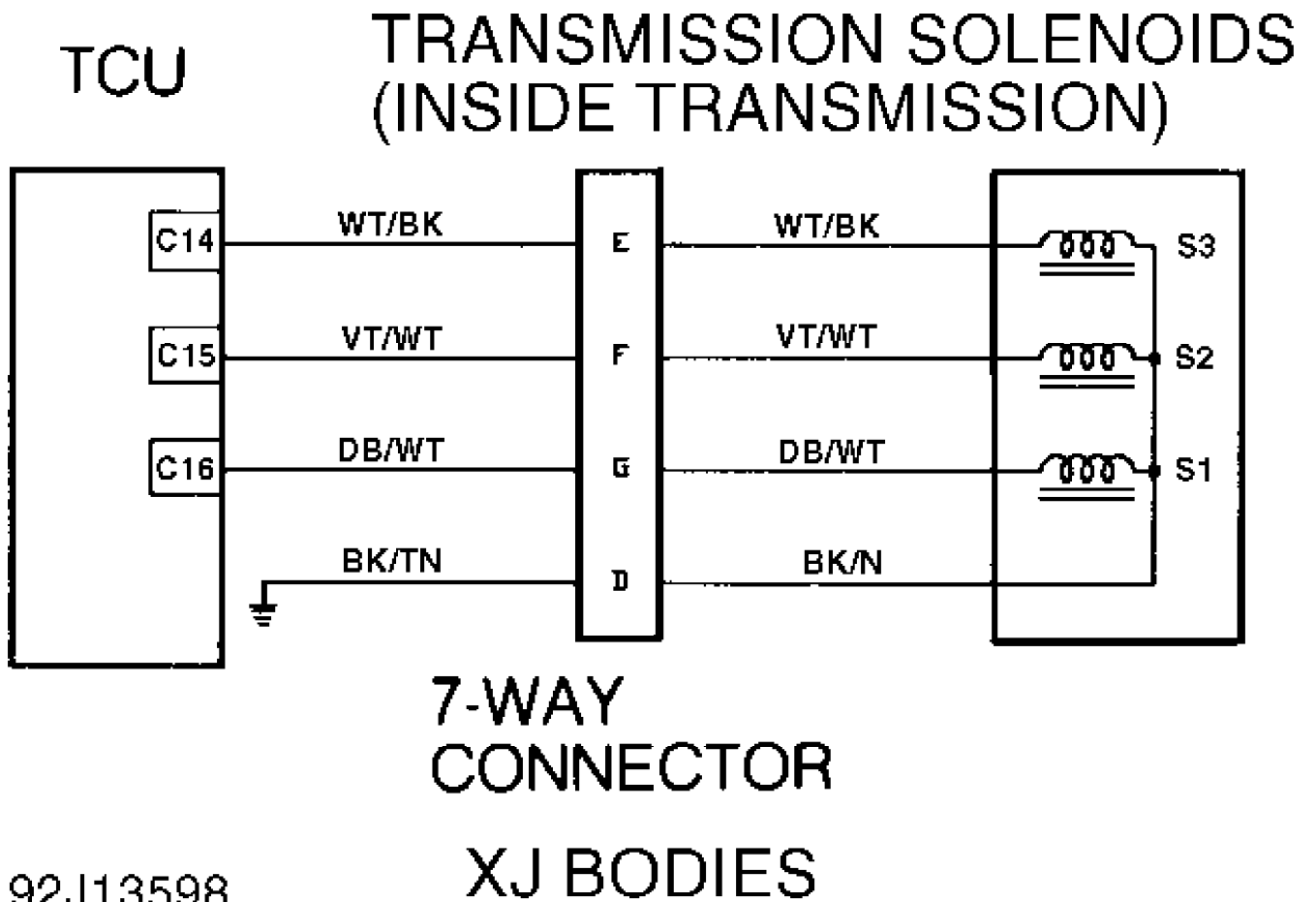

92J13598

Fig. 37: Test 4B - Code 700, Schematic (Cherokee)

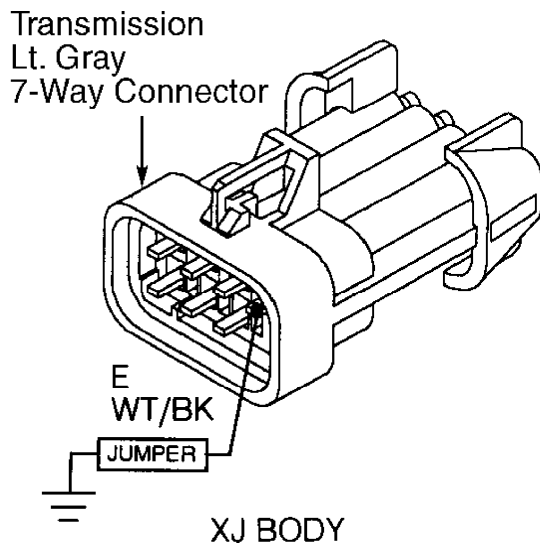

92E13619

Fig. 38: Test 4C - 7-Way Connector Cavity "E" (Cherokee)

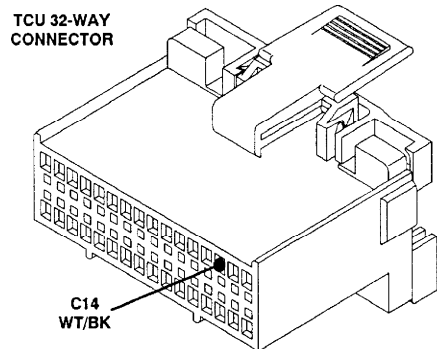

ZJ Body: LB/BR 92113621

Fig. 39: Test 4C - Code 700, TCU 32-Way Connector (Cavity 14)

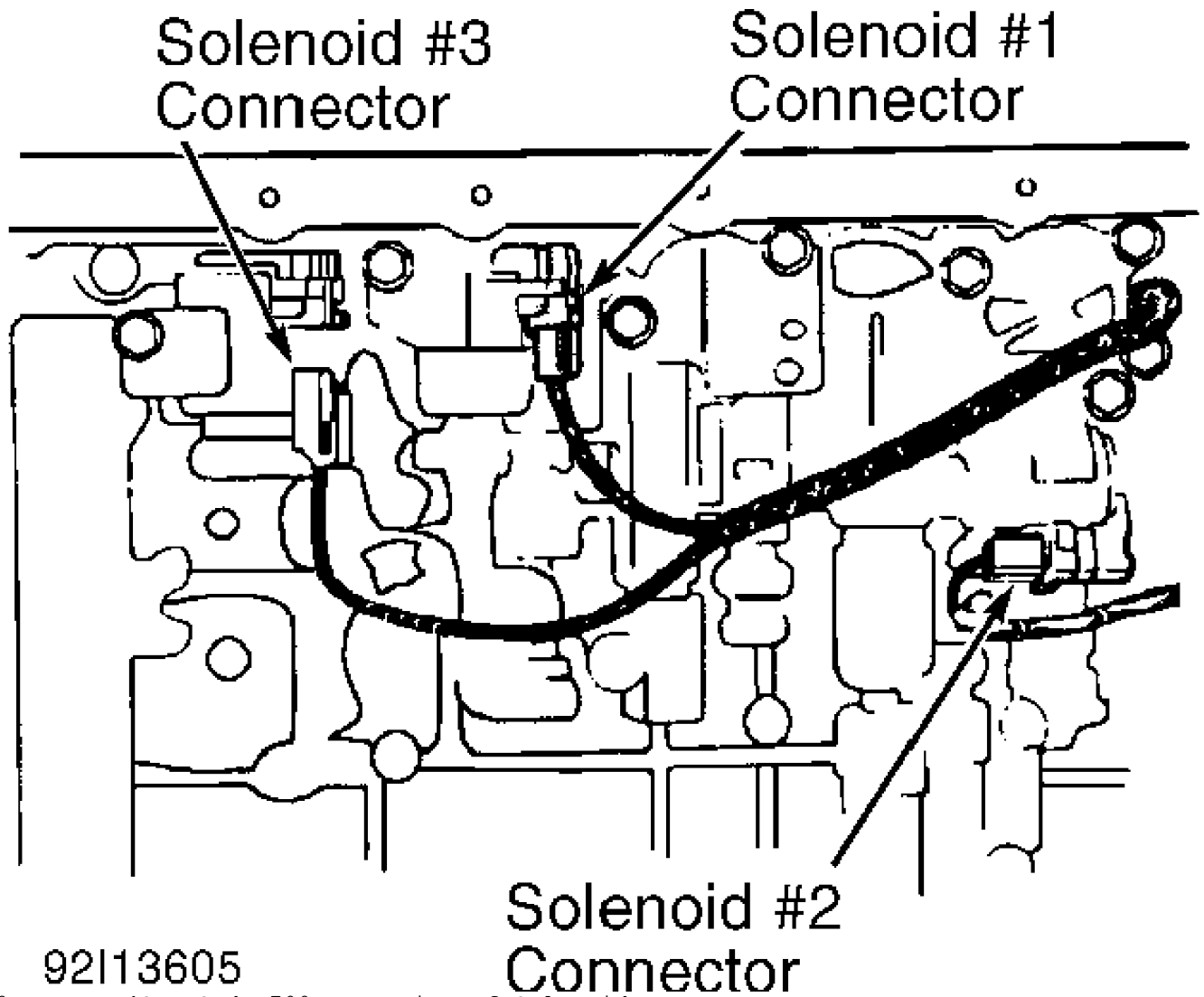
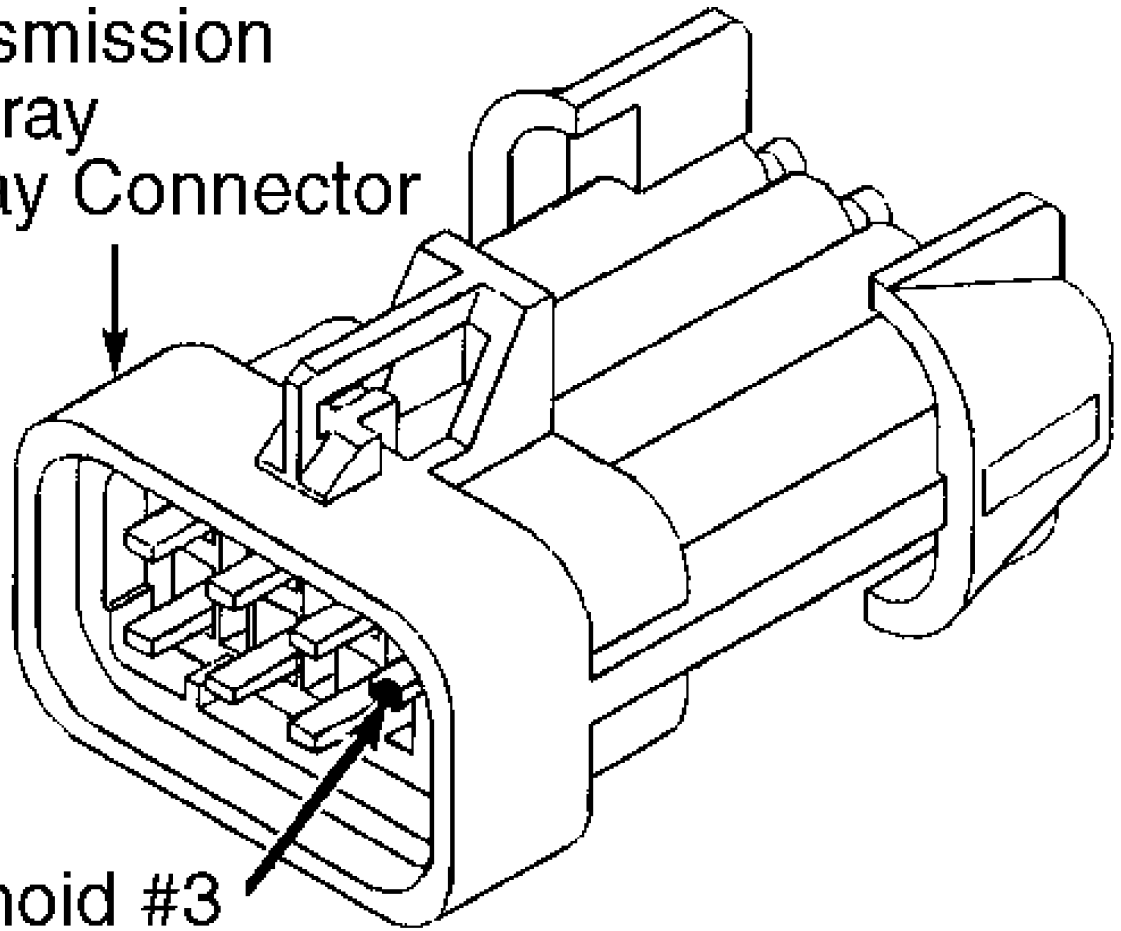

Fig. 40: Test 4C - Code 700, Location of Solenoids

Transmission
Lt. Gray
7-Way Connector



Solenoid #3
Connector

CAV	XJ	ZJ
E	WT/BK	LB/BR

92J13622

Fig. 41: Test 4C - Code 700, Solenoid No. 1 Wire (Cavity "E")

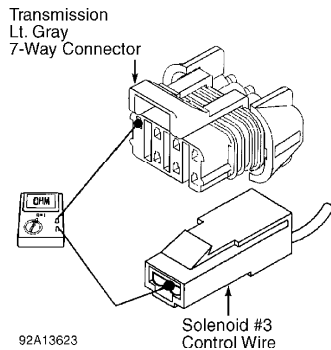

Fig. 42: Test 4C - Code 700, Testing S3 Control Wire

TEST 5A - CODE 702 - SPEED SENSOR CIRCUIT

NOTE: Perform TEST 1A - VERIFICATION OF COMPLAINT before proceeding.

Perform TEST 1A before proceeding.

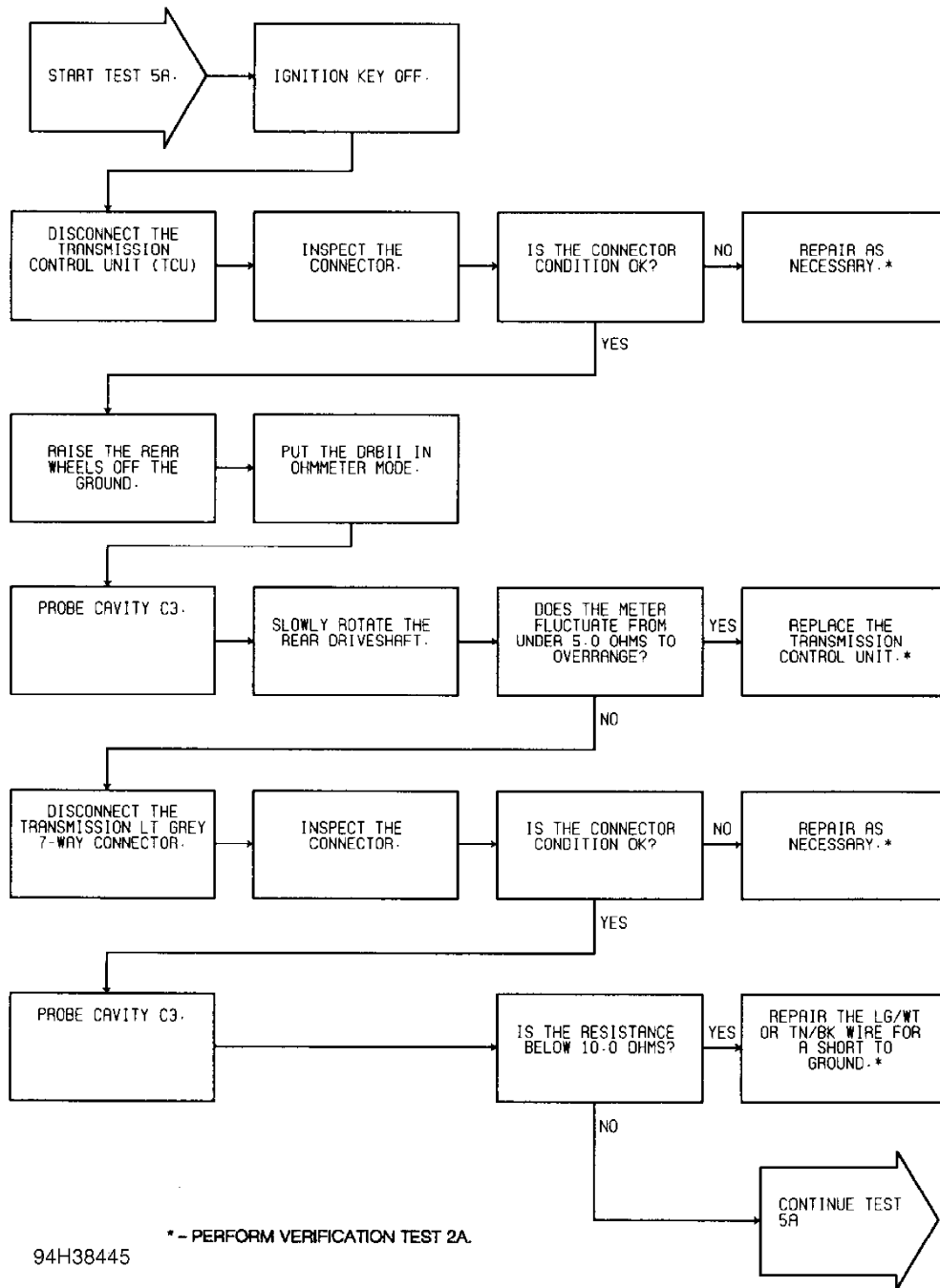

Fig. 43: Test 5A - Code 702, Flow Chart (1 of 2)

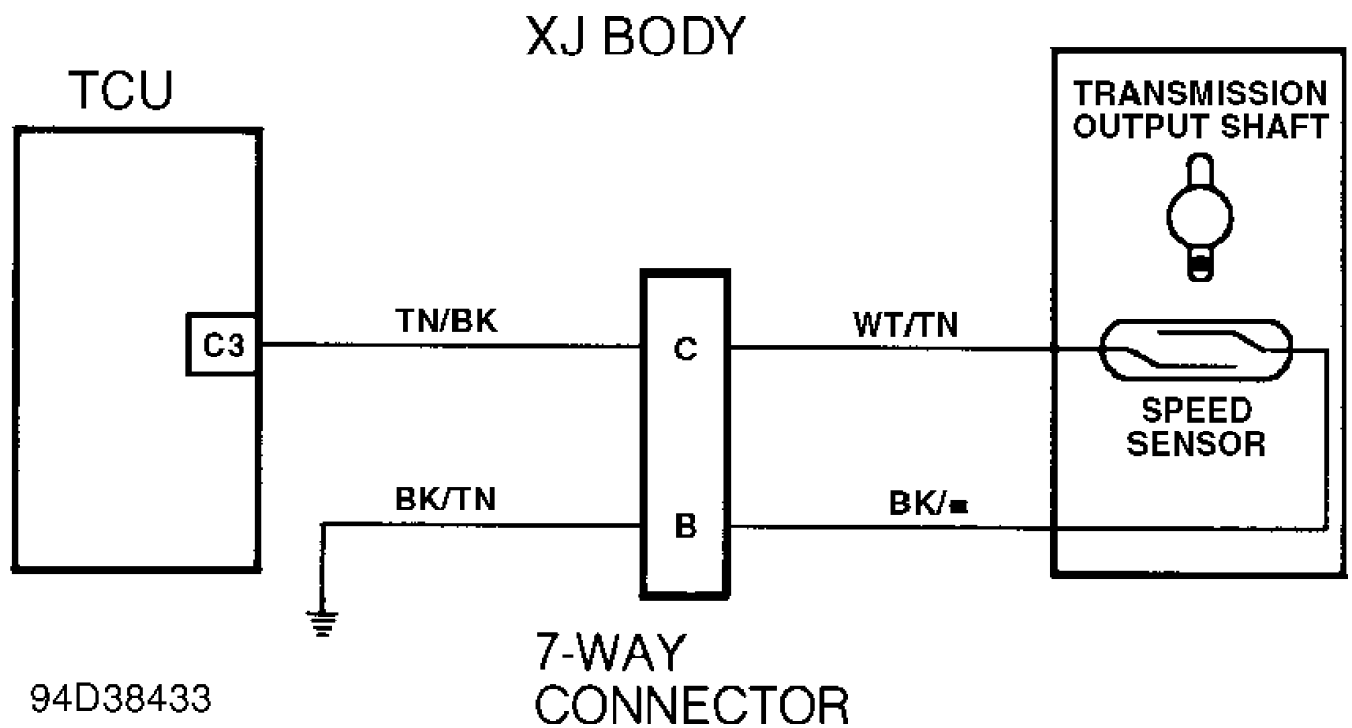

Fig. 44: Test 5A - Code 702, Speed Sensor Schematic (Cherokee)

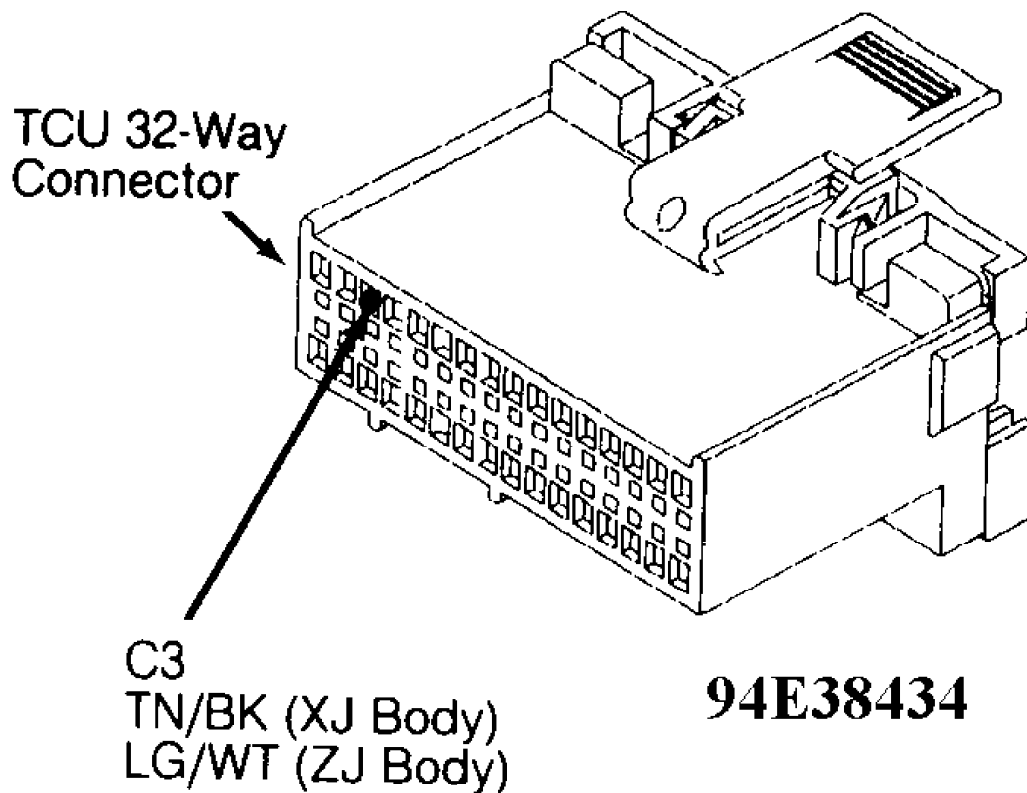
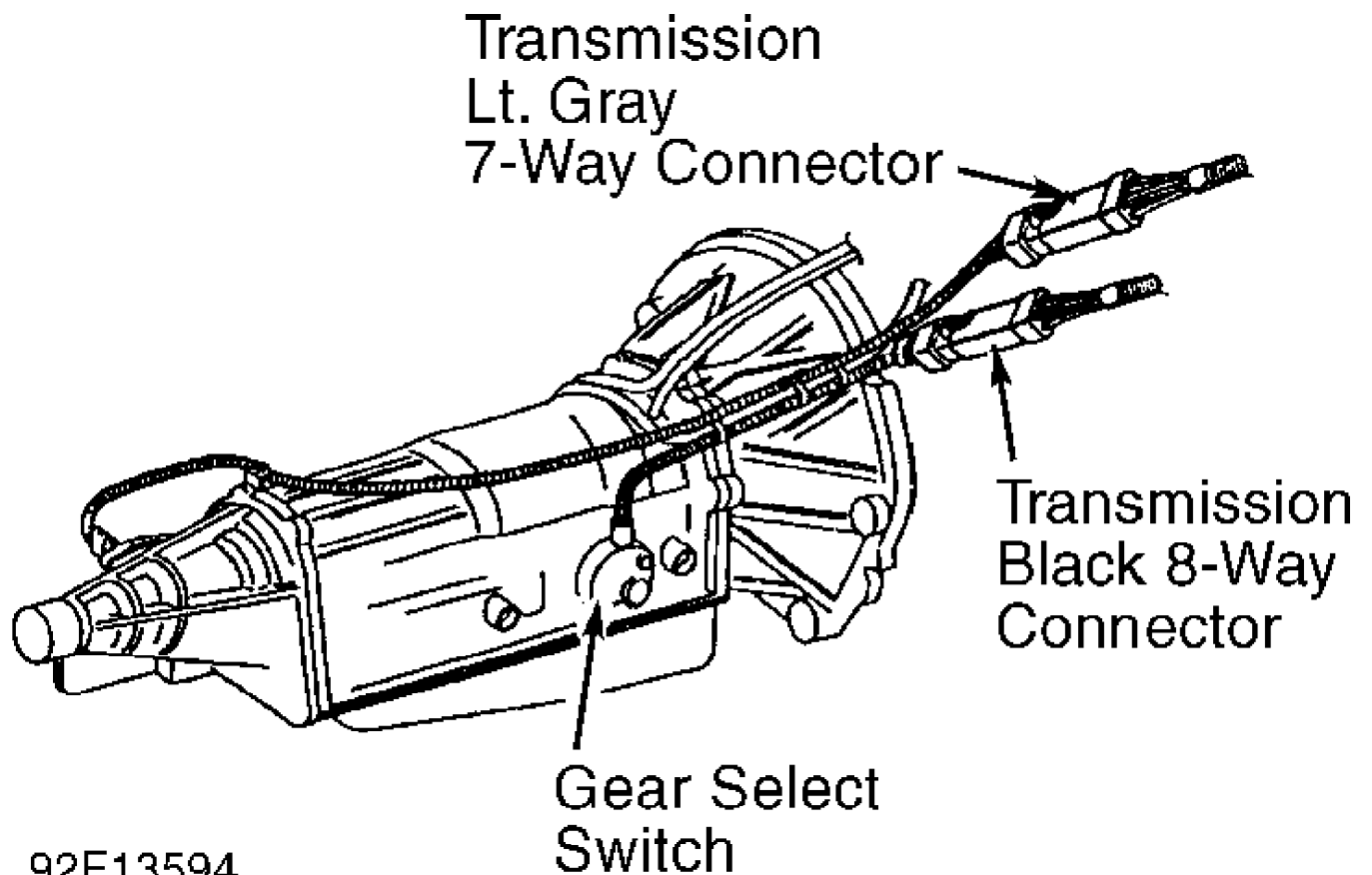
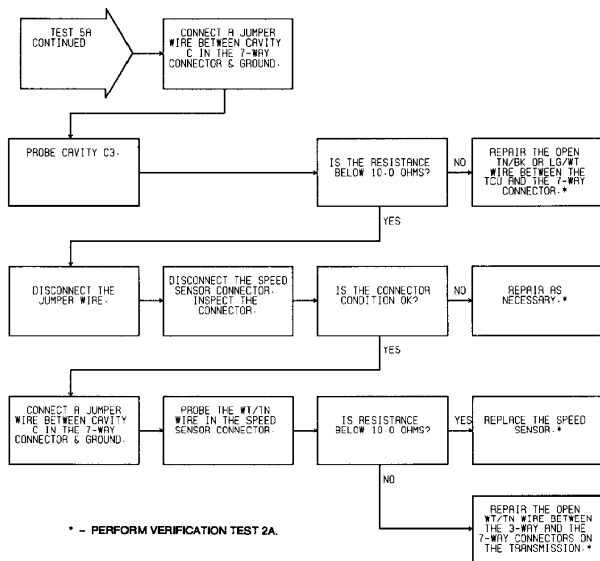

Fig. 45: Test 5A - Code 702, TCU 32-Way Connector (Cavity 3)



92F13594

Fig. 46: Test 5A - Code 702, Location of 7-Way Connector



NOTE: See TEST 5A (1 OF 2) for wiring diagram.

94F38435
Fig. 47: Test 5A - Code 702, Flow Chart (2 of 2)

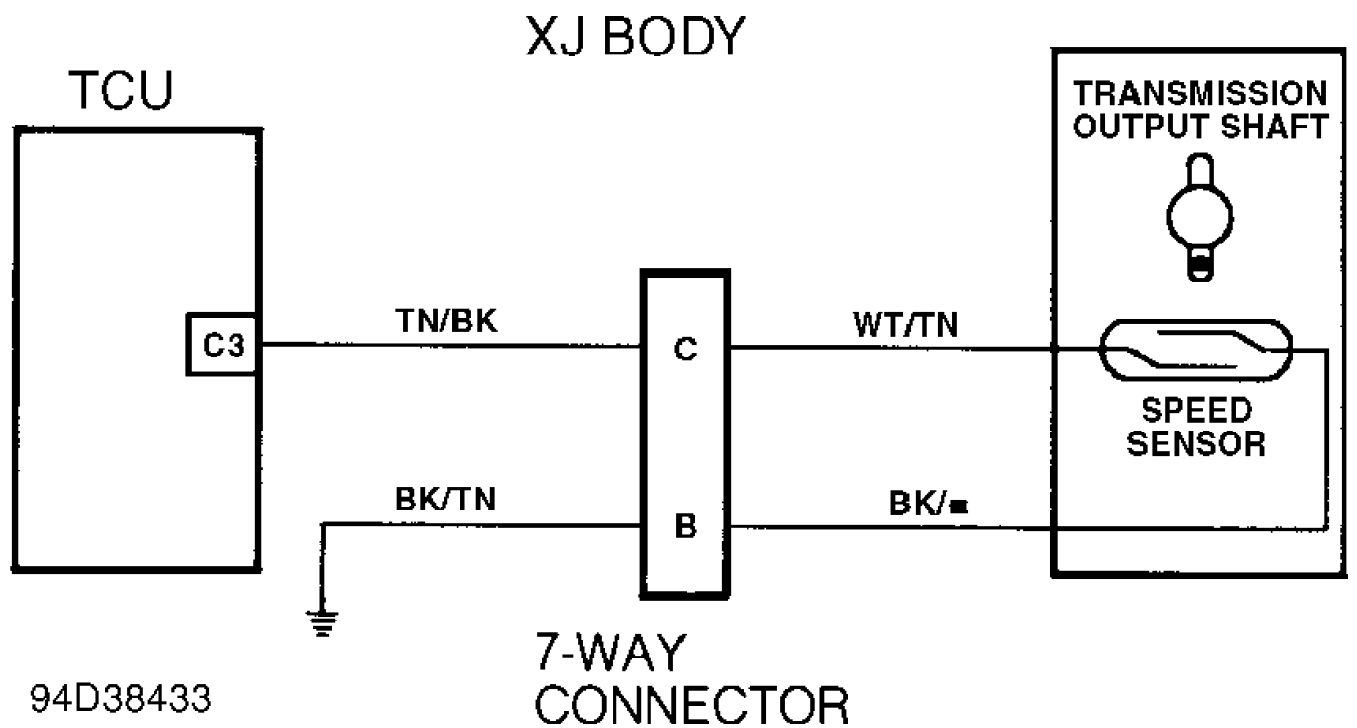

Fig. 48: Test 5A - Code 702, Speed Sensor Schematic (Cherokee)

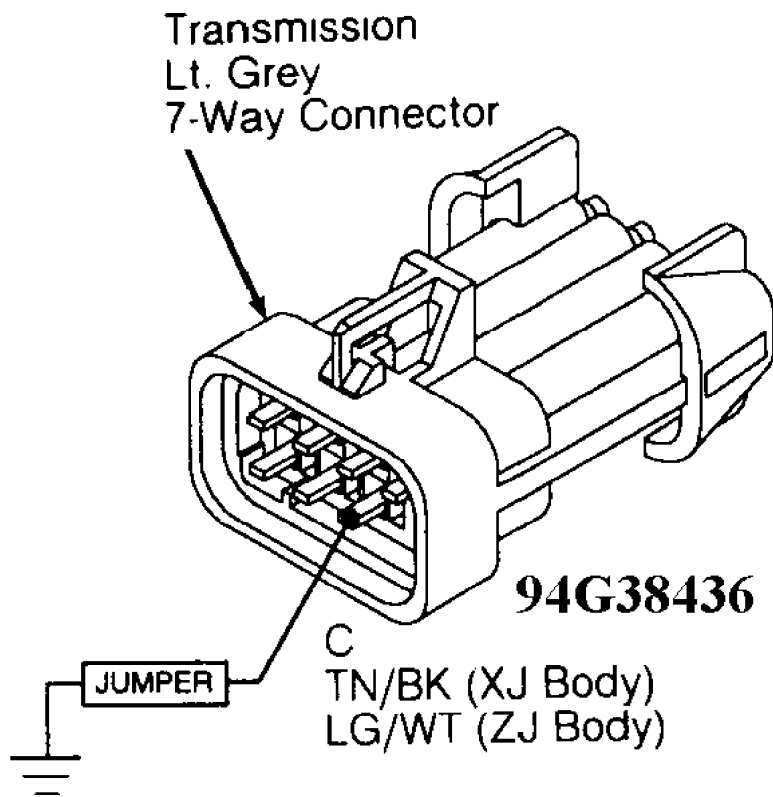

Fig. 49: Test 5A - Transmission 7-Way Connector (Male Side)

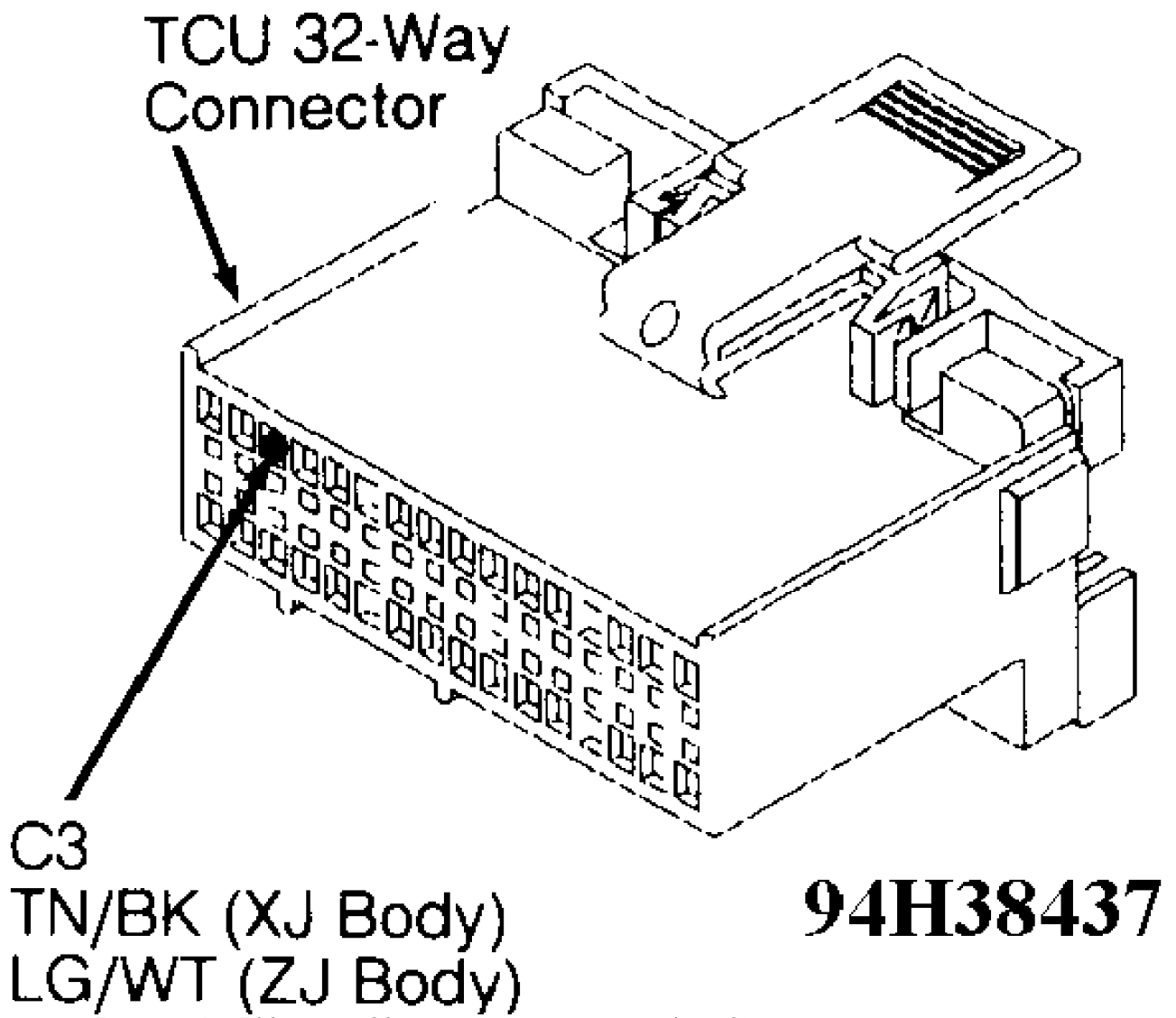

Fig. 50: Test 5A - Code 702, TCU 32-Way Connector (Cavity 3)

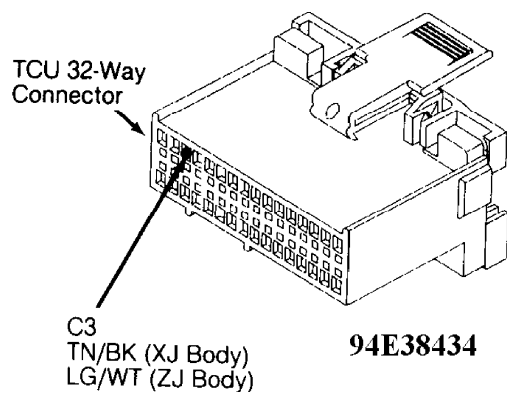
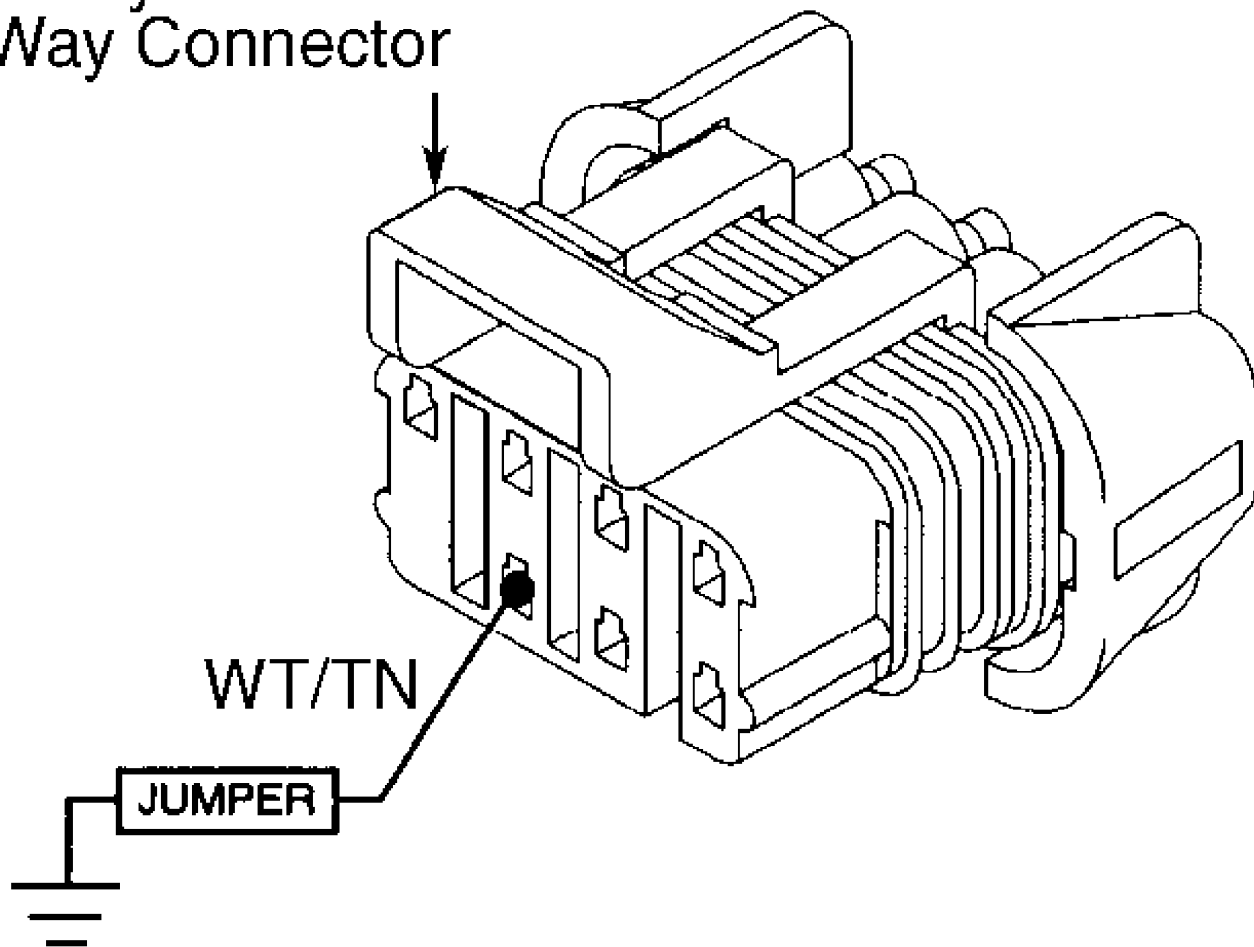

Fig. 51: Test 5A - Code 702, TCU 32-Way Connector (Cavity 3)

Transmission Lt. Gray 7-Way Connector



92H14255

Fig. 52: Test 5A - Transmission 7-Way Connector (Female Side)

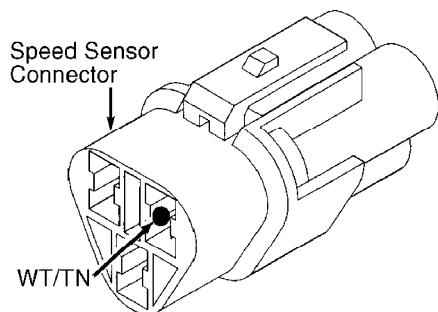

92H14256
Fig. 53: Test 5A - Code 702, View of Speed Sensor Connector

TEST 6A - CODE 703 - GEAR SELECT SWITCH CIRCUIT

Perform TEST 1A before proceeding.

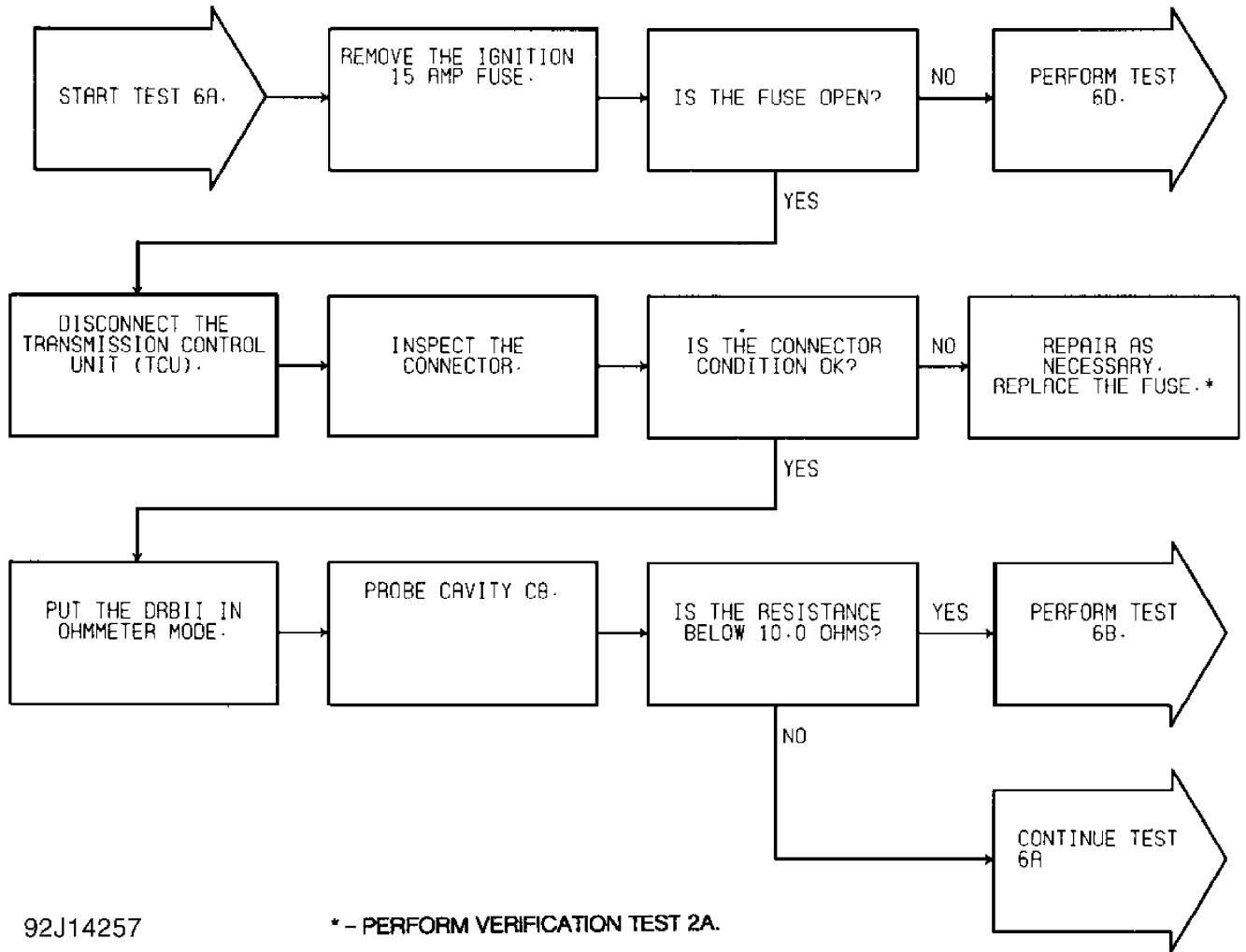

92J14257

* - PERFORM VERIFICATION TEST 2A.

Fig. 54: Test 6A - Code 703, Flow Chart (1 of 2)

MJ and XJ Bodies

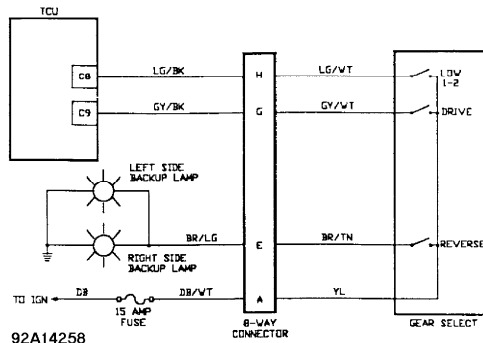

92A14258

Fig. 55: Test 6A - Gear Select Switch Schematic (Cherokee)

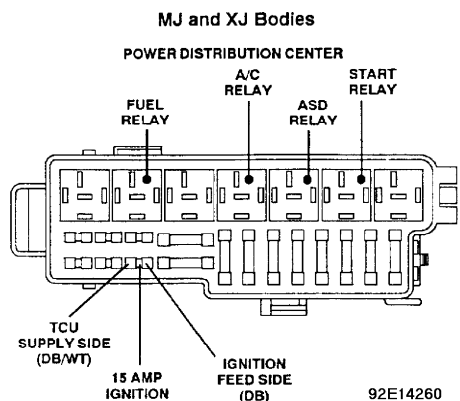
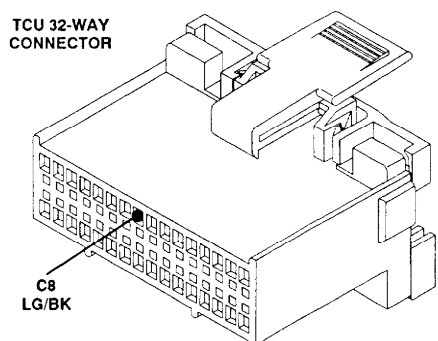
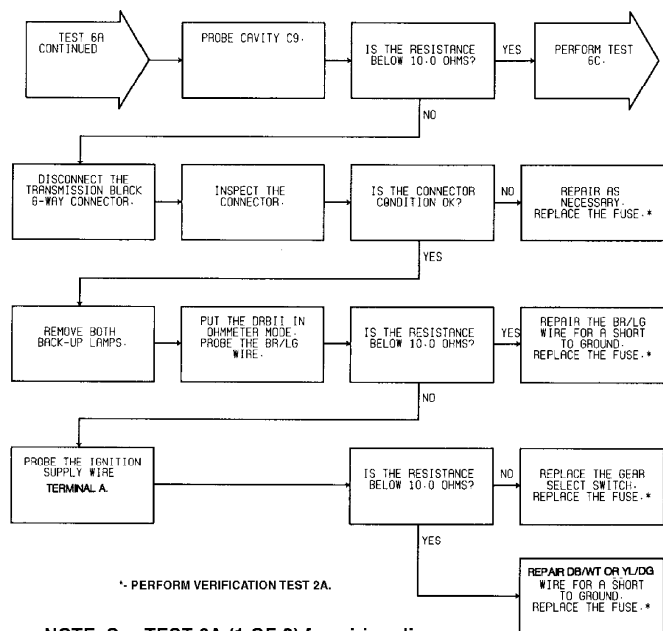

Fig. 56: Test 6A - Location of Gear Select Switch Fuse (Cherokee)



ZJ Body: LG 92G14262
Fig. 57: Test 6A - TCU 32-Way Connector (Cavity 8)



NOTE: See TEST 6A (1 OF 2) for wiring diagram.

92H14263
Fig. 58: Test 6A - Code 703, Flow Chart (2 of 2)

MJ and XJ Bodies

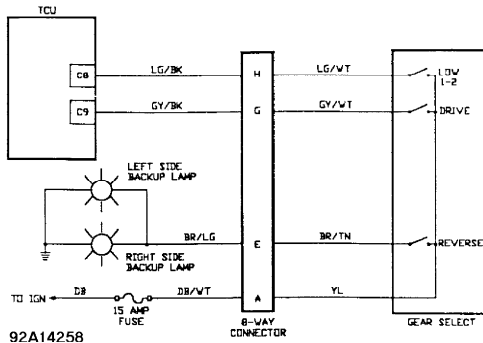

92A14258

Fig. 59: Test 6A - Gear Select Switch Schematic (Cherokee)

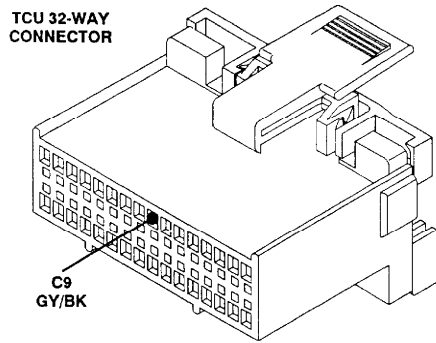

ZJ Body: DG

92I14264

Fig. 60: Test 6A - Code 703, TCU 32-Way Connector (Cavity 9)

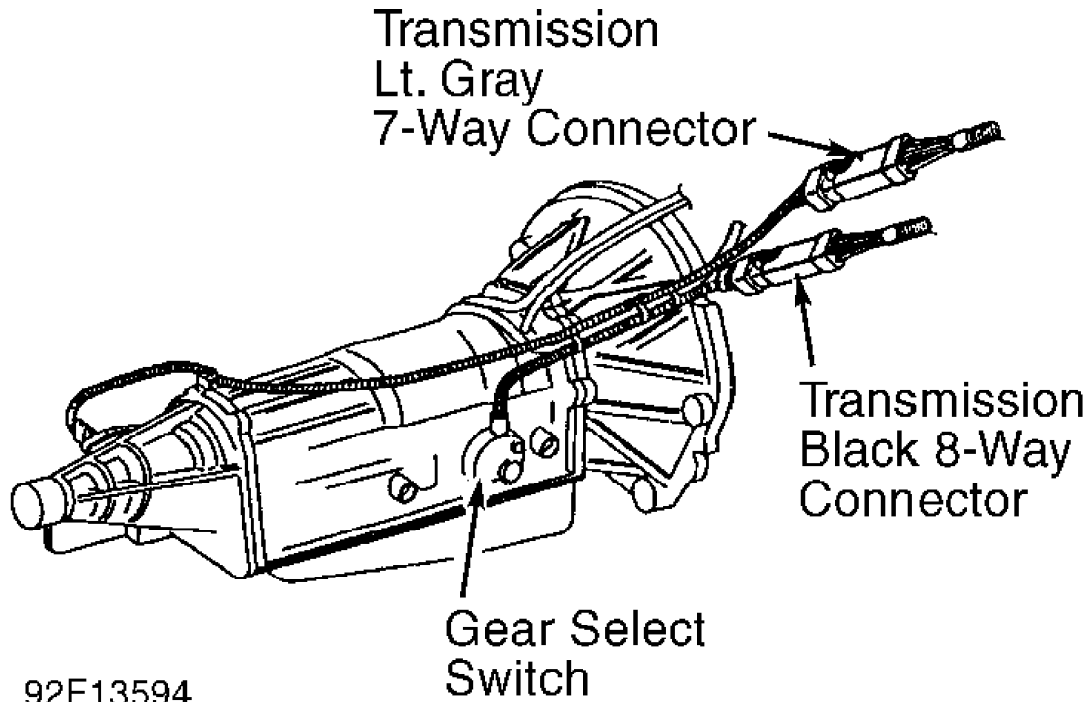

92F13594

Fig. 61: Test 6A - Code 703, Location of Gear Select Switch

Transmission Black 8-Way Connector

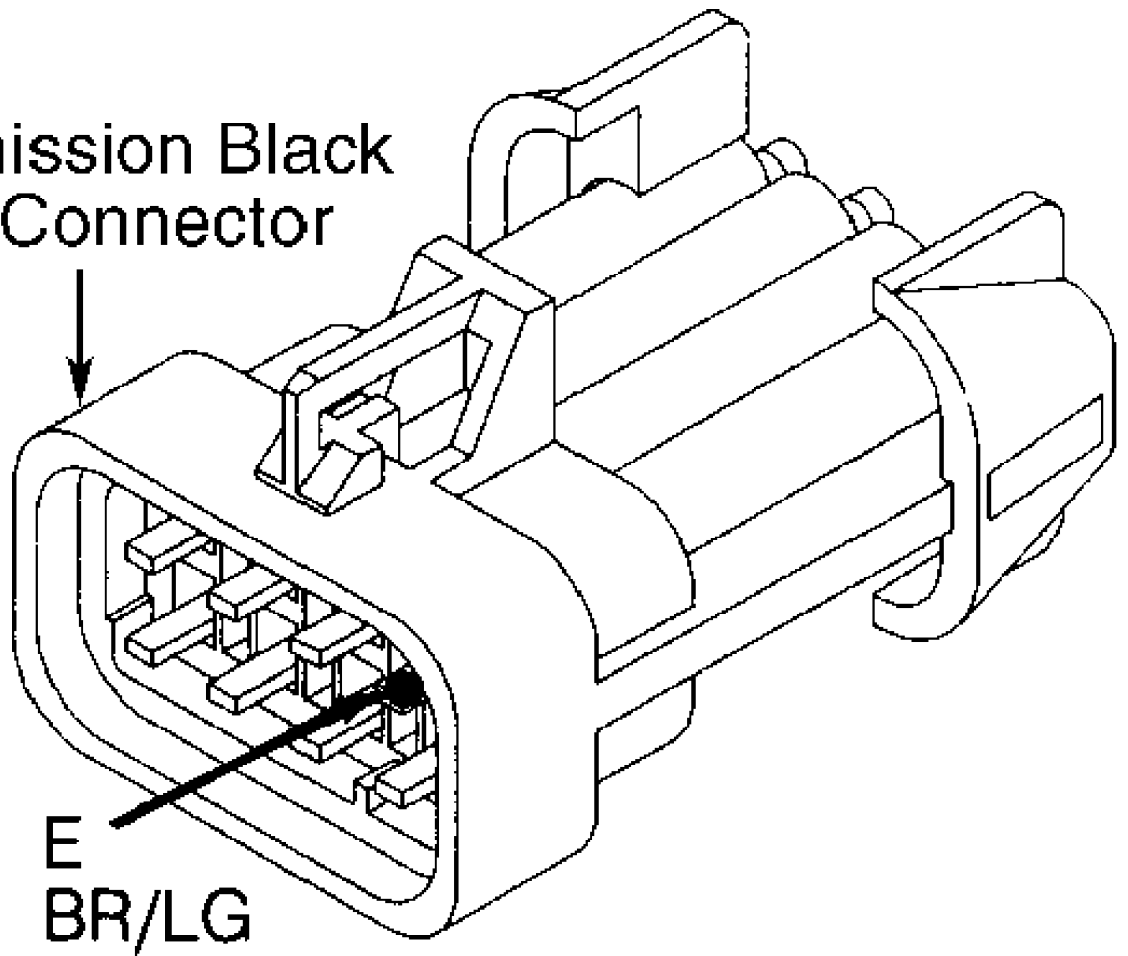

92J14265

Fig. 62: Test 6A - Code 703, 8-Way Black Connector Cavity "E"

XJ BODY

Transmission Black 8-Way Connector

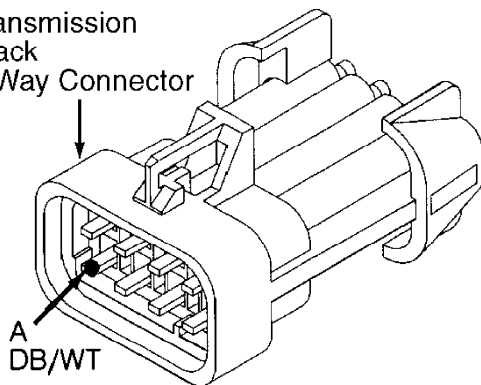

92A14266

Fig. 63: Test 6A - 8-Way Black Connector Cavity "A" (Cherokee)

TEST 6B - CODE 703 - GEAR SELECT SWITCH CIRCUIT

NOTE: Perform TEST 6A - CODE 703 - GEAR SELECT SWITCH CIRCUIT

before proceeding.

Perform TEST 6A before proceeding.

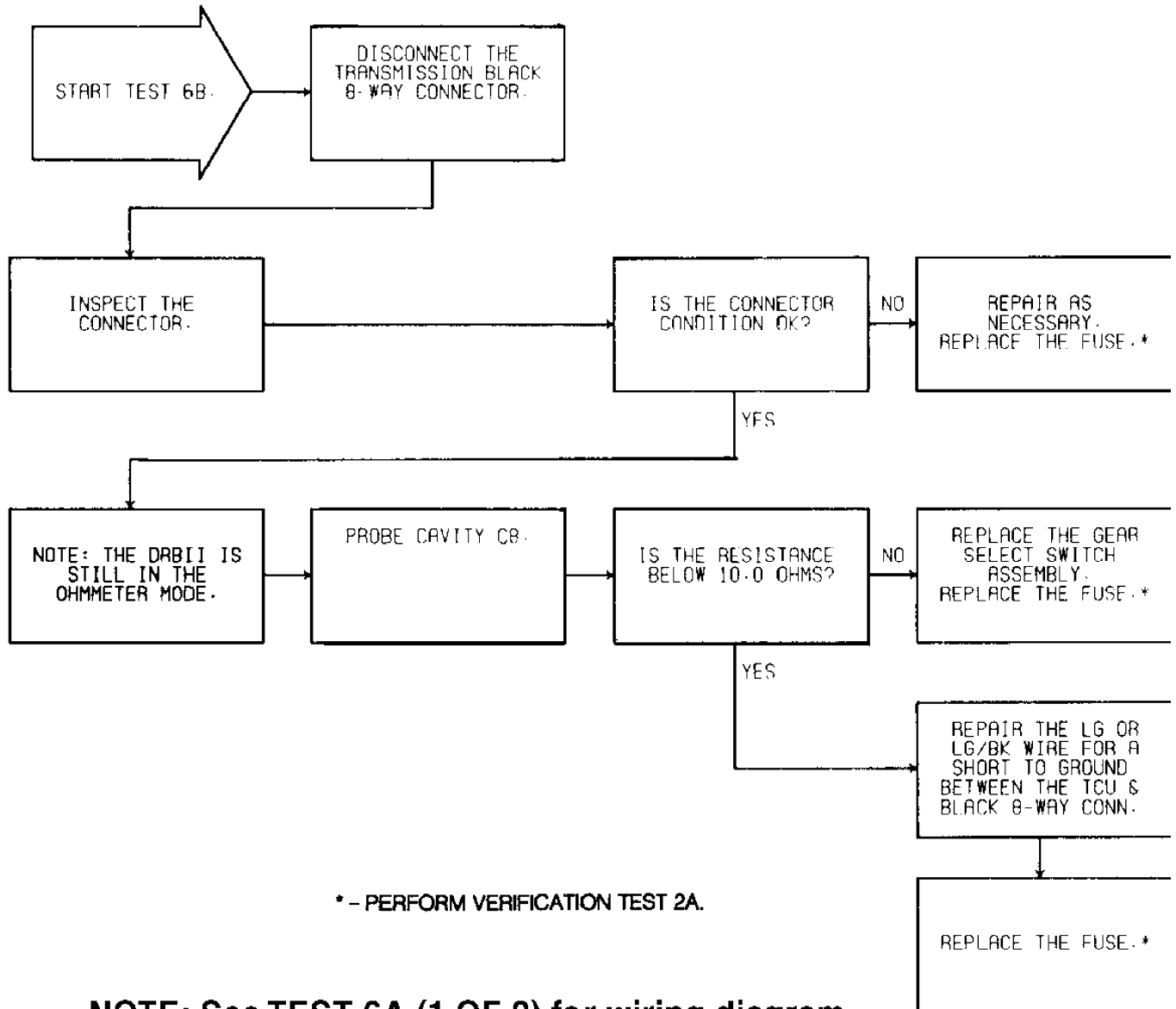

NOTE: See TEST 6A (1 OF 2) for wiring diagram.

92C14268

Fig. 64: Test 6B - Code 703, Flow Chart

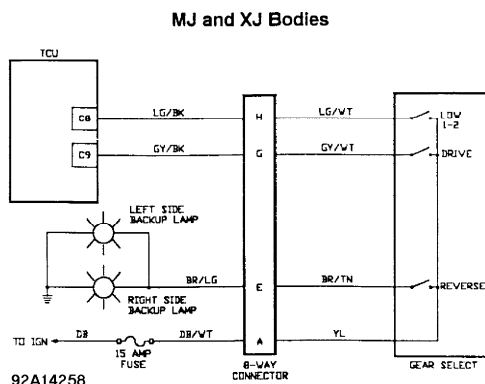

Fig. 65: Test 6B - Gear Select Switch Schematic (Cherokee)

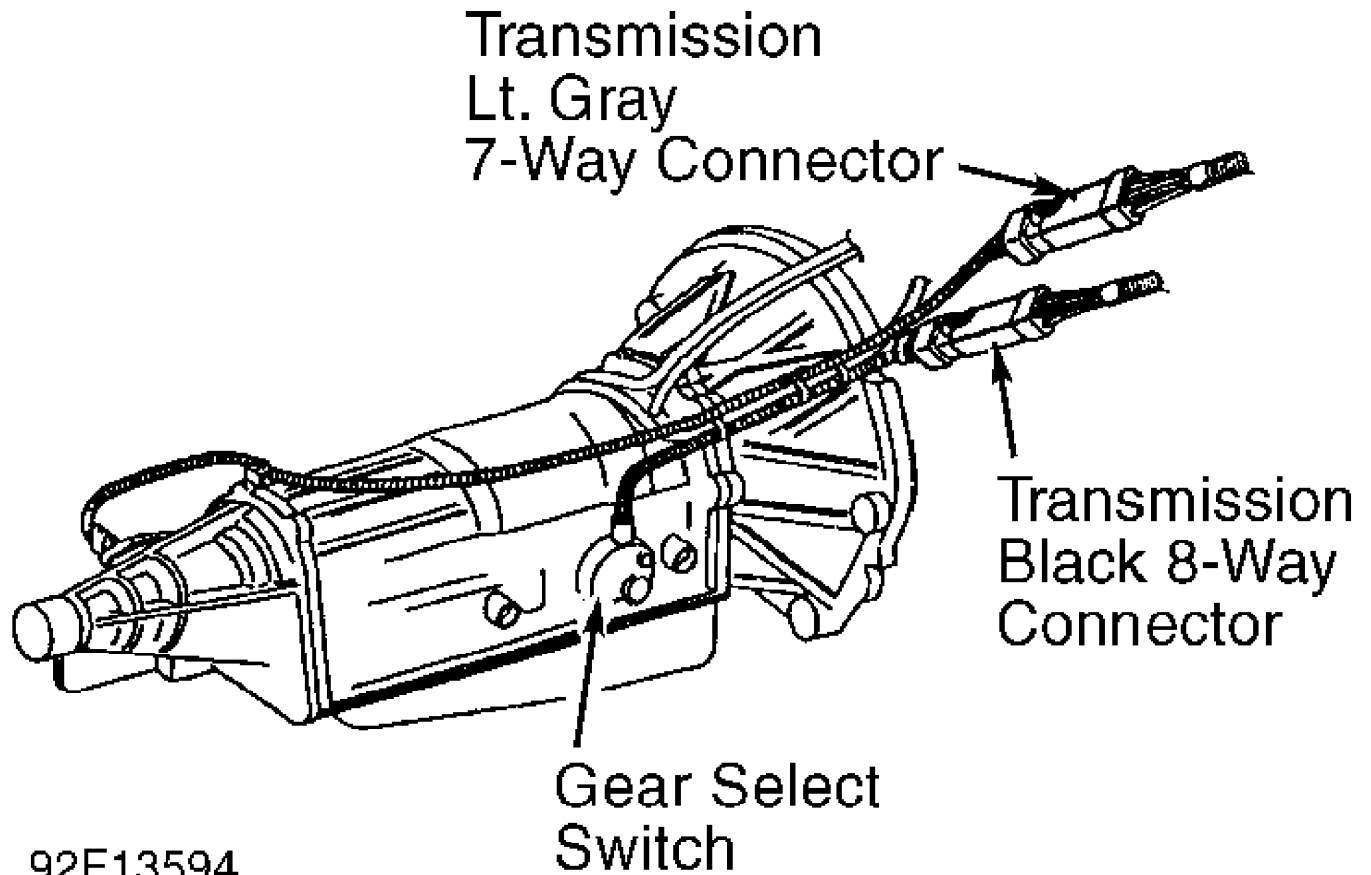

Fig. 66: Test 6B - Code 703, Location of Gear Select Switch

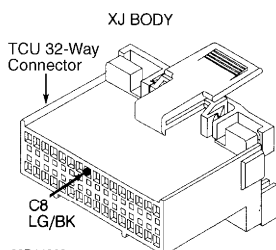
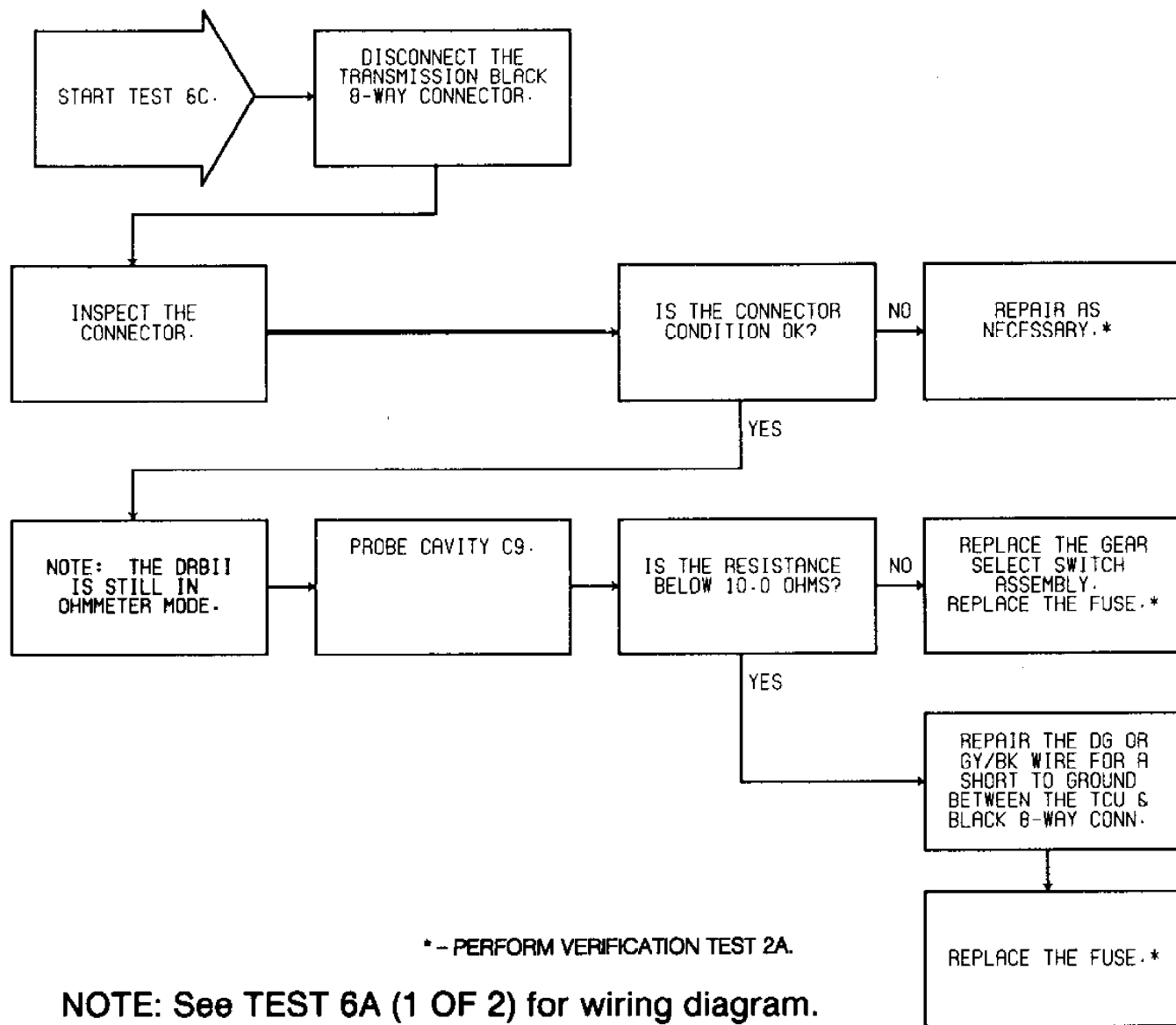

Fig. 67: Test 6B - TCU 32-Way Connector (Cavity 8, Cherokee)

TEST 6C - CODE 703 - GEAR SELECT SWITCH CIRCUIT

NOTE: Perform TEST 6A - CODE 703 - GEAR SELECT SWITCH CIRCUIT before proceeding.

Perform TEST 6A before proceeding.



92H14271
Fig. 68: Test 6C - Code 703, Flow Chart

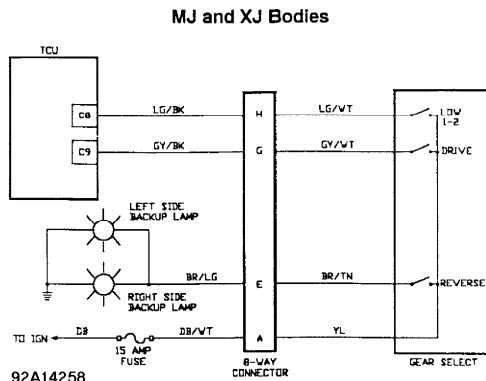

Fig. 69: Test 6C - Gear Select Switch Schematic (Cherokee)

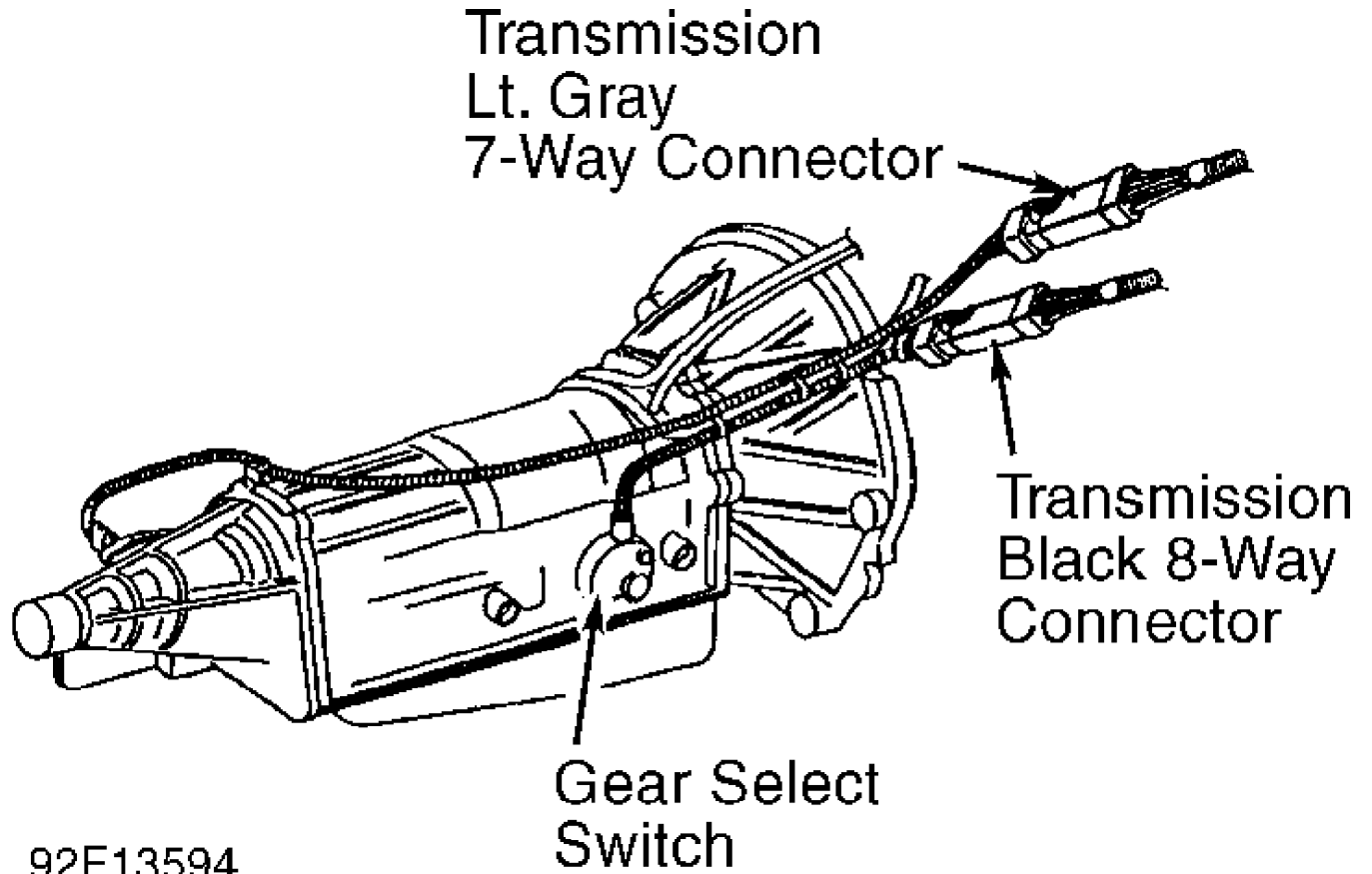

Fig. 70: Test 6C - Code 703, Location of Gear Select Switch

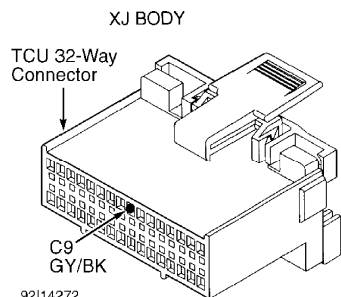

Fig. 71: Test 6C - TCU 32-Way Connector (Cavity 9, Cherokee)

TEST 6D - CODE 703 - GEAR SELECT SWITCH CIRCUIT

NOTE: Perform TEST 6A - CODE 703 - GEAR SELECT SWITCH CIRCUIT before proceeding.

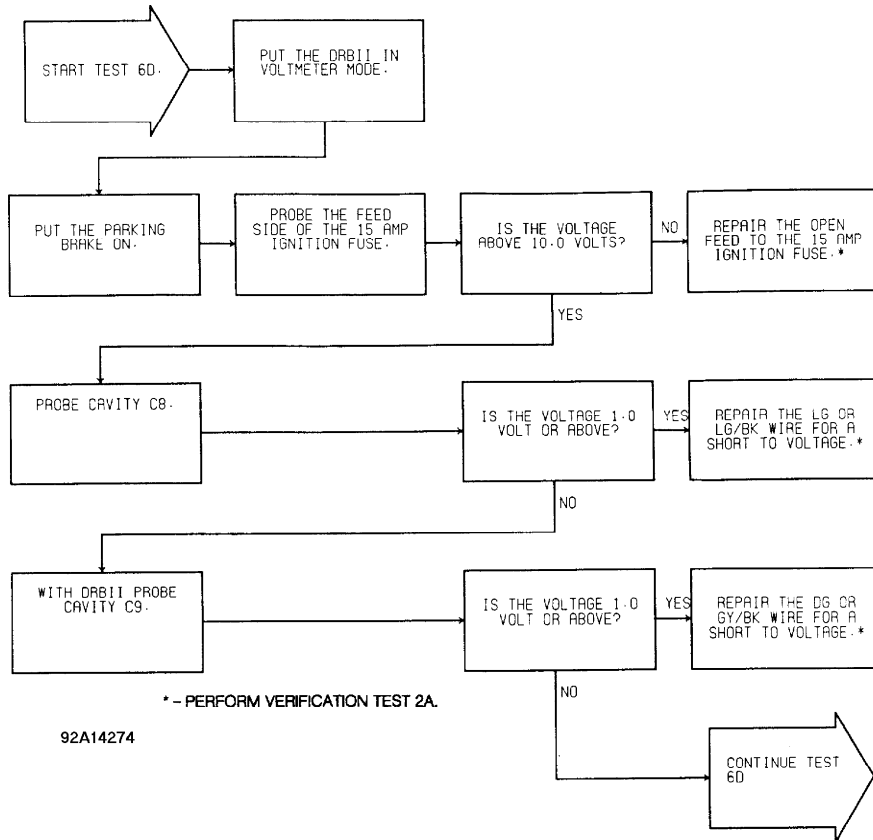

Fig. 72: Test 6D - Code 703, Flow Chart (1 of 3)

MJ and XJ Bodies

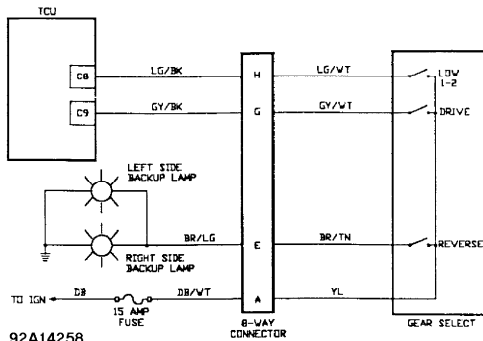

Fig. 73: Test 6D - Gear Select Switch Schematic (Cherokee)

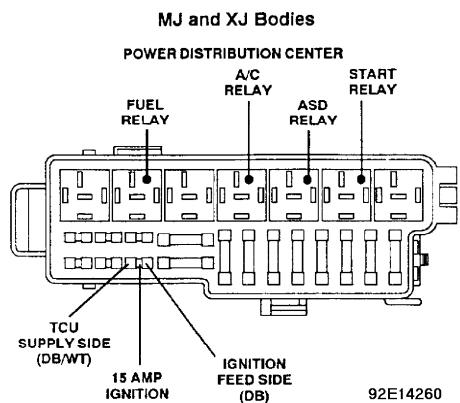

Fig. 74: Test 6D - Location of Gear Select Switch Fuse (Cherokee)

XJ BODY

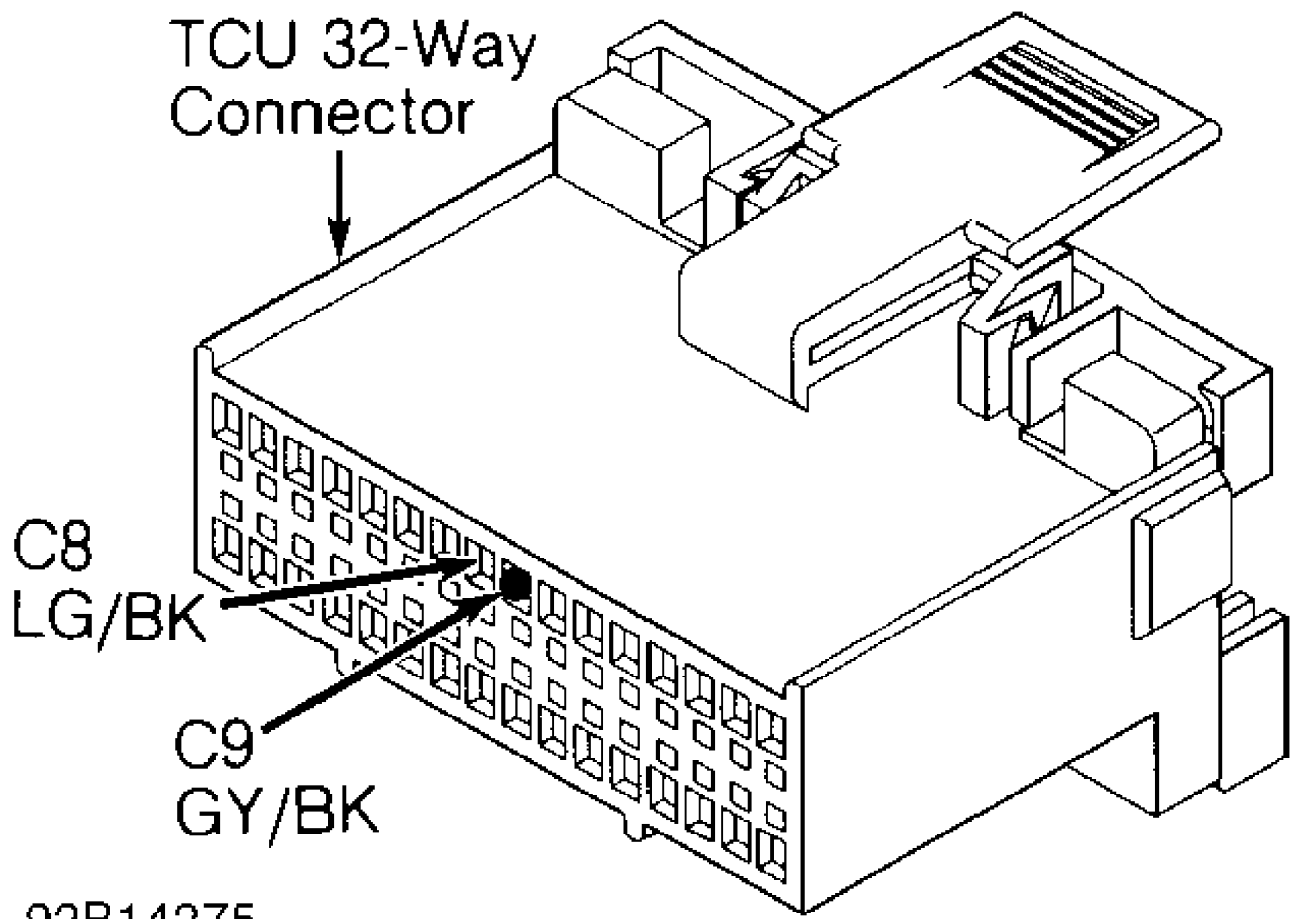
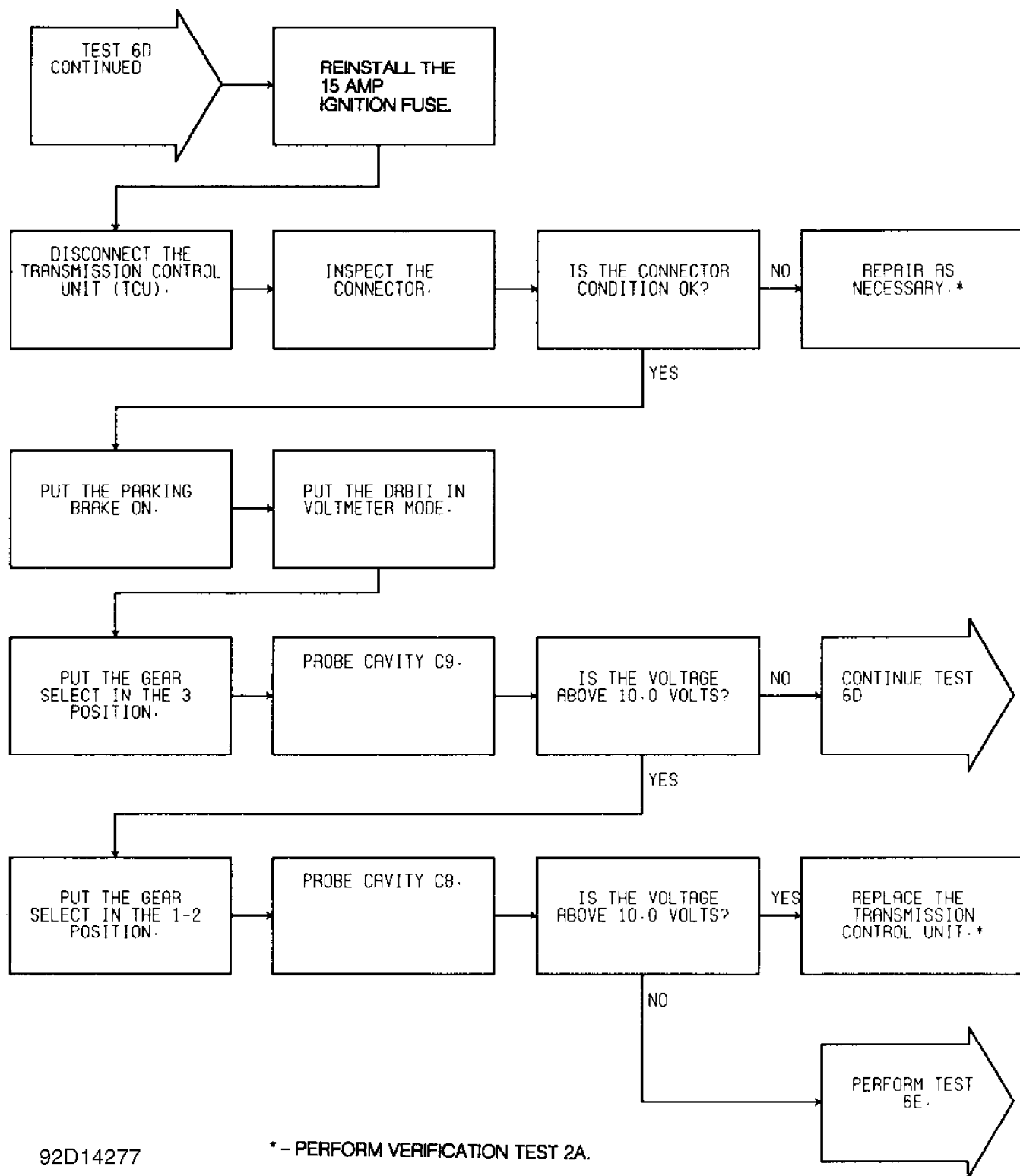

Fig. 75: Test 6D - TCU 32-Way Connector (Cavities 8 & 9, Cherokee)



92D14277

* - PERFORM VERIFICATION TEST 2A.

Fig. 76: Test 6D - Code 703, Flow Chart (2 of 3)

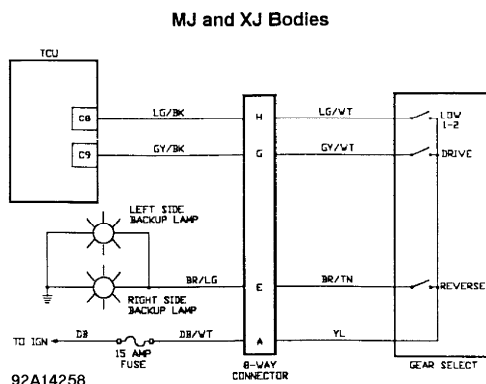

92A14258
Fig. 77: Test 6D - Gear Select Switch Schematic (Cherokee)

XJ BODY

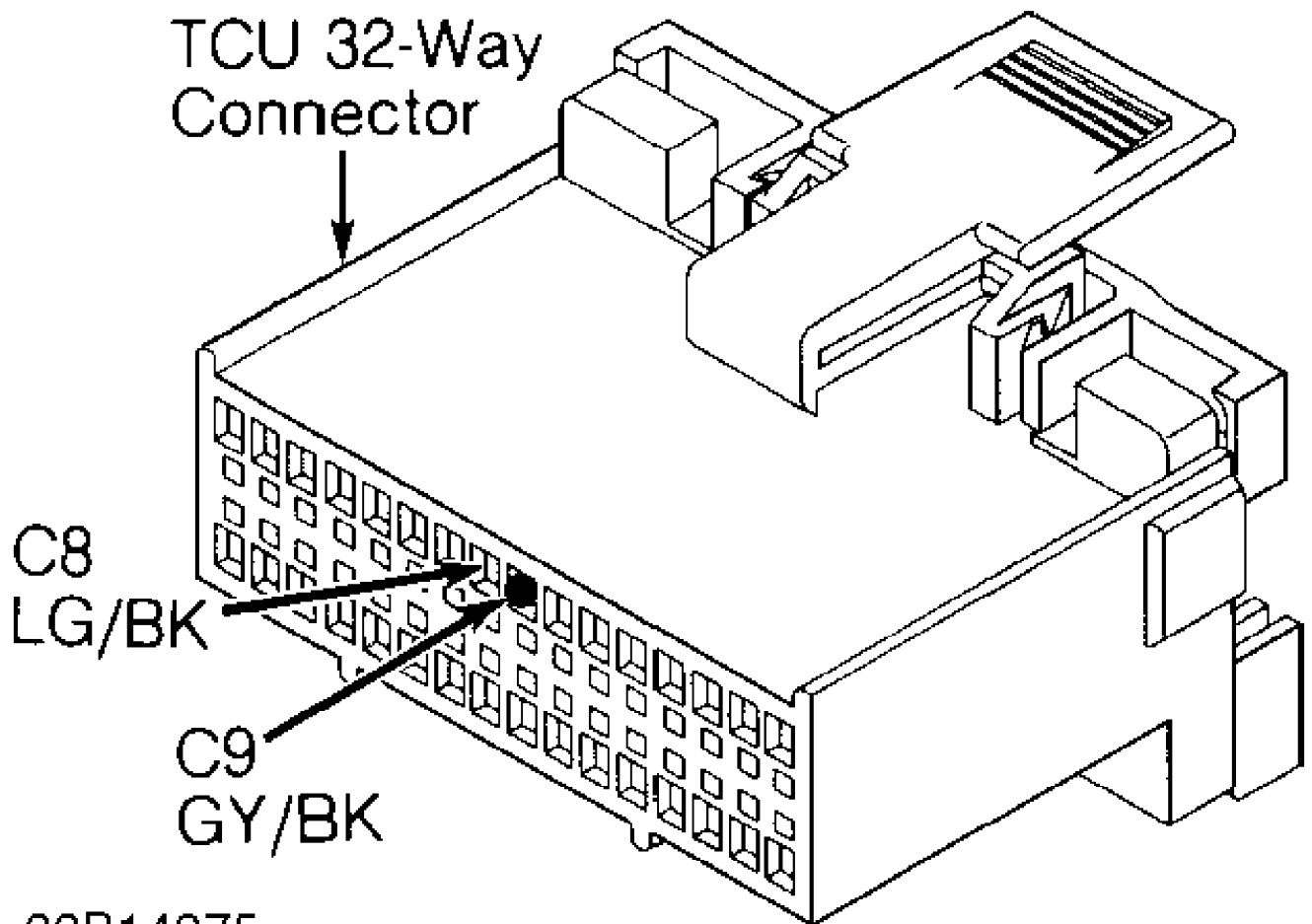

92B14275
Fig. 78: Test 6D - TCU 32-Way Connector (Cavities 8 & 9, Cherokee)

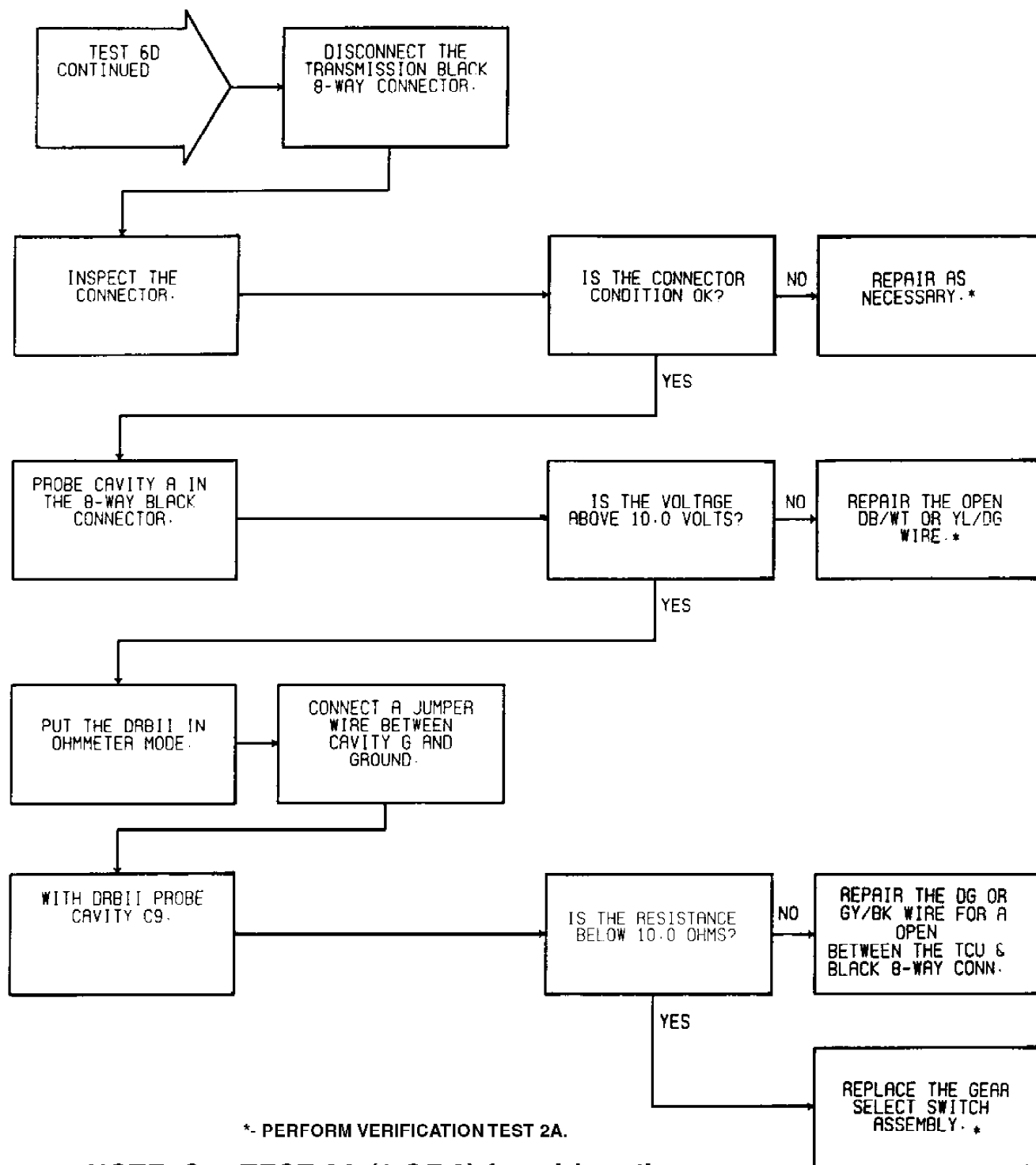

NOTE: See TEST 6A (1 OF 2) for wiring diagram.

92E14278

Fig. 79: Test 6D - Code 703, Flow Chart (3 of 3)

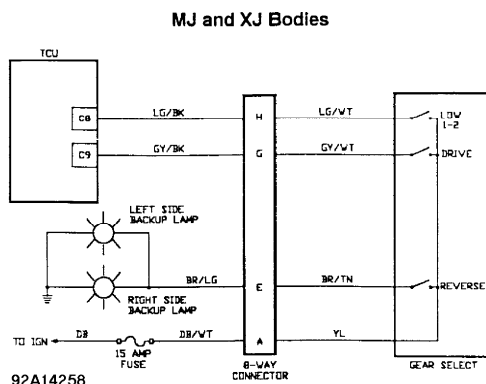

Fig. 80: Test 6D - Gear Select Switch Schematic (Cherokee)

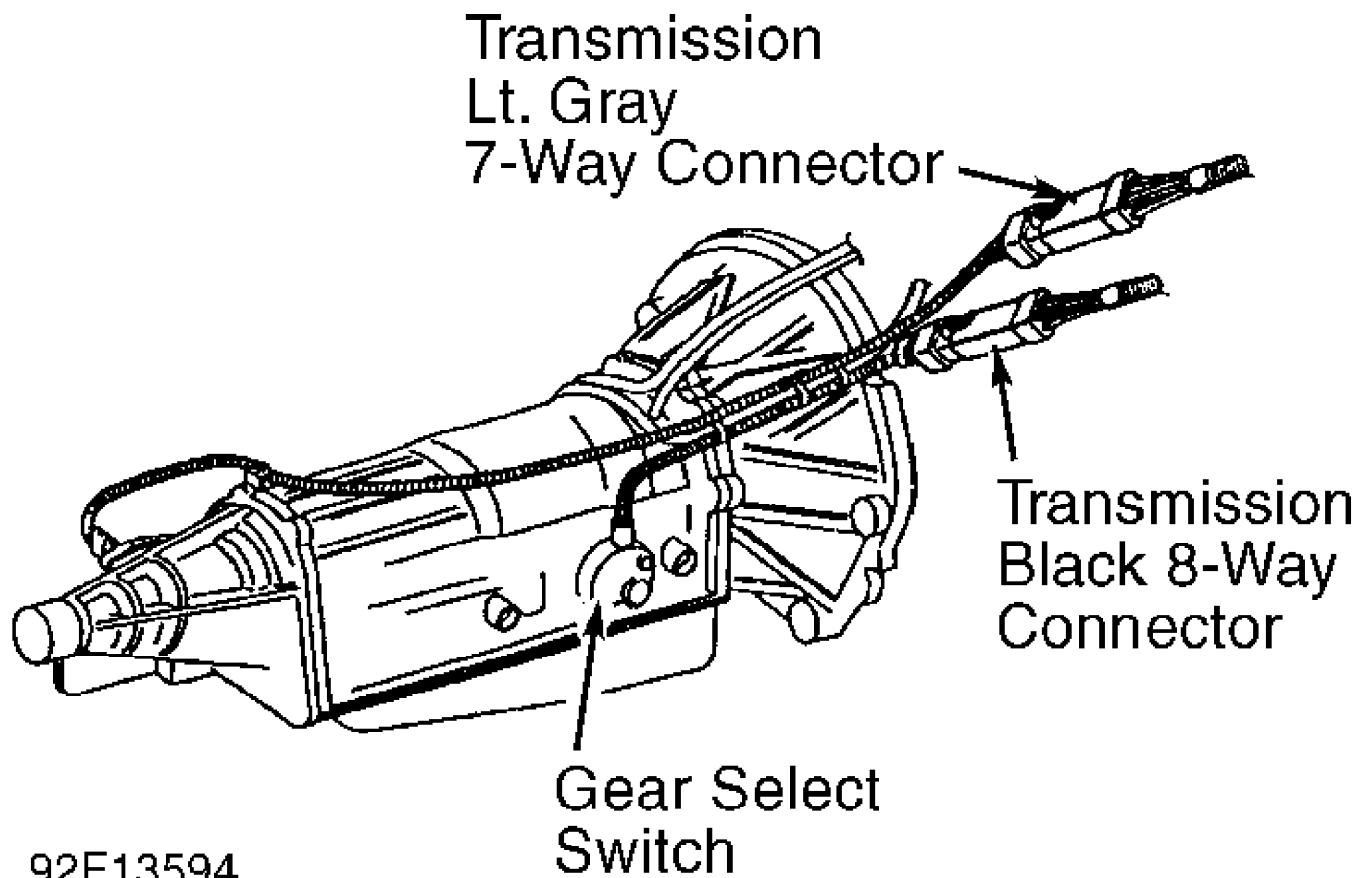

Fig. 81: Test 6D - Code 703, Location of Gear Select Switch

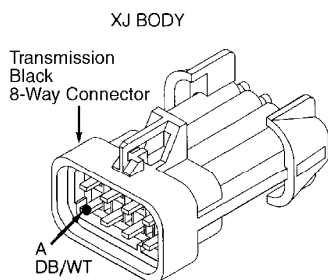
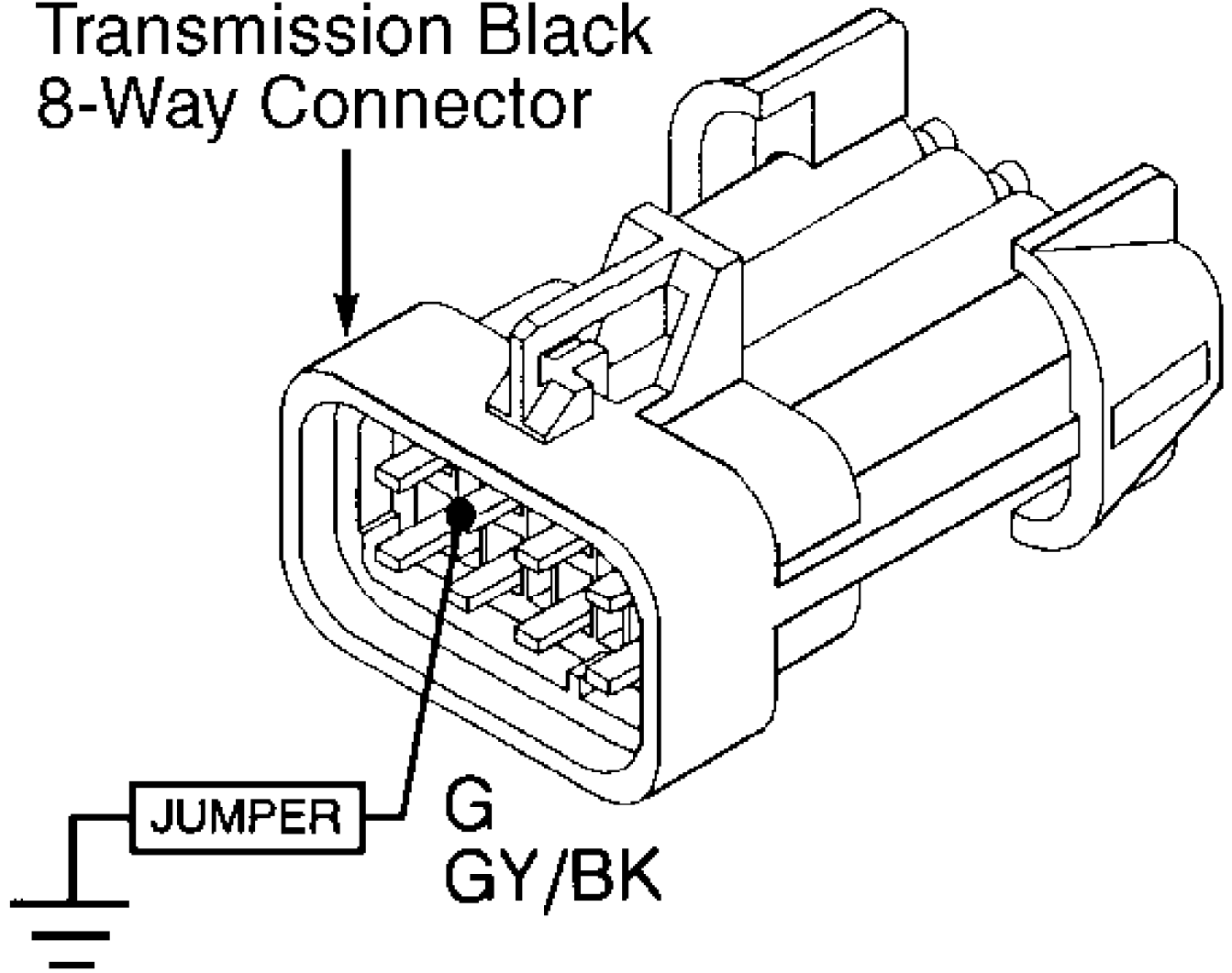

Fig. 82: Test 6D - 8-Way Black Connector Cavity "A" (Cherokee)

XJ BODY

Transmission Black
8-Way Connector



92F14279

Fig. 83: Test 6D - 8-Way Black Connector Cavity "G" (Cherokee)

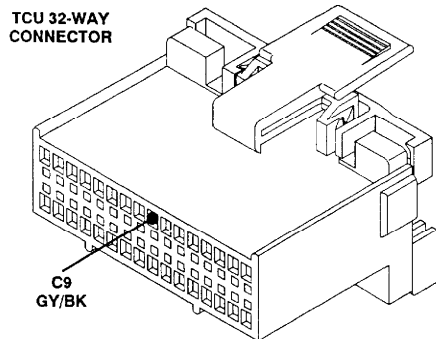

ZJ Body: DG 92J14264

Fig. 84: Test 6D - Code 703, TCU 32-Way Connector (Cavity 9)

TEST 6E - CODE 703 - GEAR SELECT SWITCH CIRCUIT

NOTE: Perform TEST 6D - CODE 703 - GEAR SELECT SWITCH CIRCUIT before proceeding.

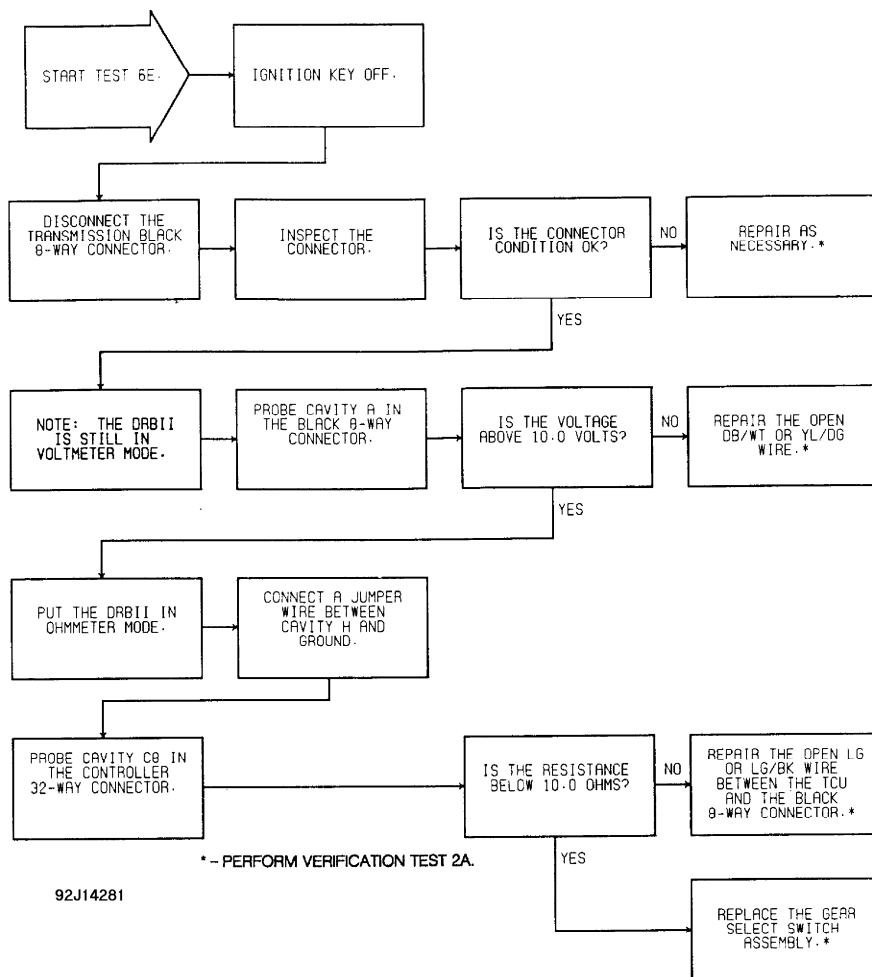
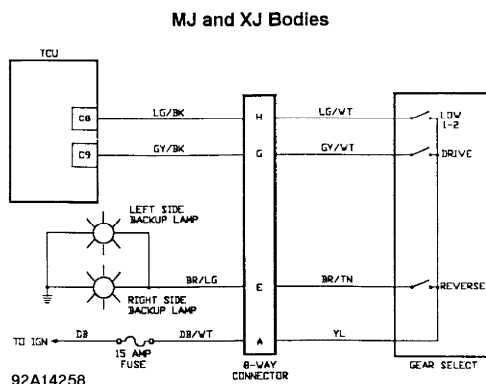

Fig. 85: Test 6E - Code 703, Flow Chart



92A14258
Fig. 86: Test 6E - Gear Select Switch Schematic (Cherokee)

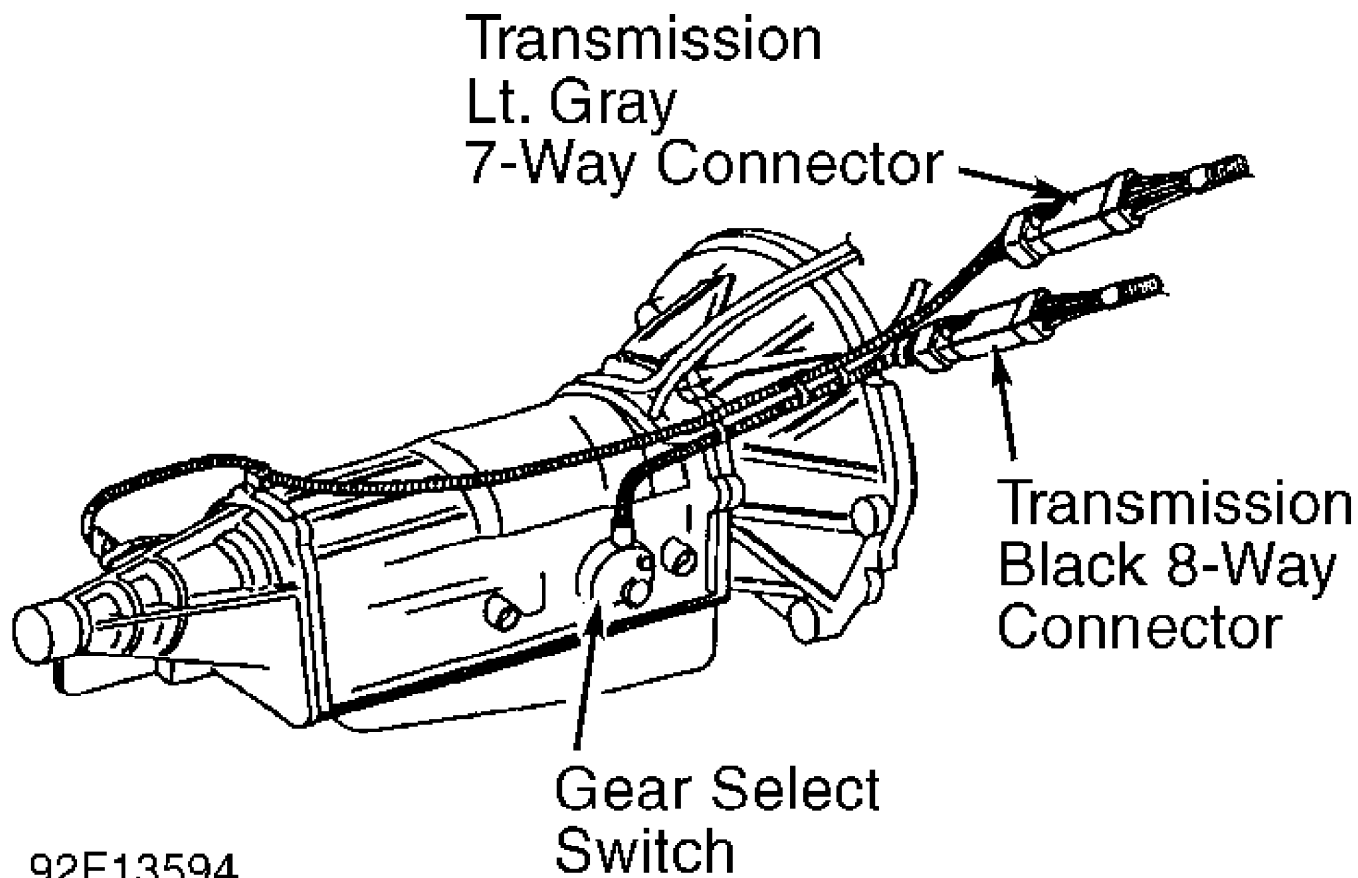
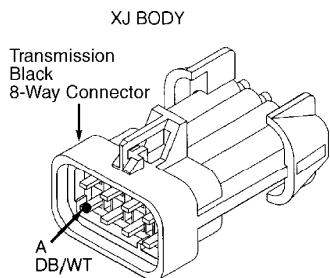

Fig. 87: Test 6E - Code 703, Location of Gear Select Switch



92A14266
Fig. 88: Test 6E - 8-Way Black Connector Cavity "A" (Cherokee)

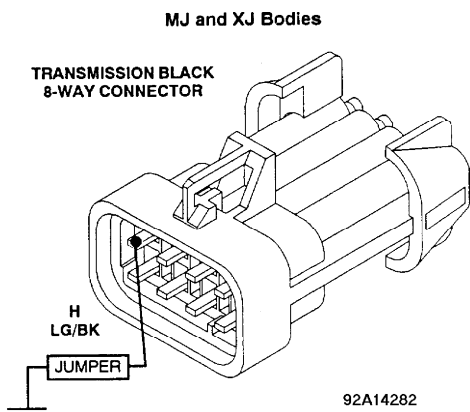

Fig. 89: Test 6E - 8-Way Black Connector Cavity "H" (Cherokee)

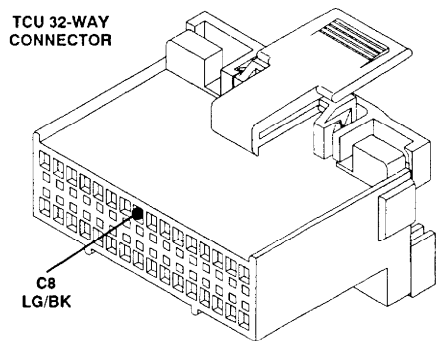

Fig. 90: Test 6E - TCU 32-Way Connector (Cavity 8)

TEST 7A - CODE 705 - TPS CIRCUIT

NOTE: Perform TEST 1A - VERIFICATION OF COMPLAINT before proceeding.

NOTE: On Cherokee, engine diagnostic connector is located at left side of engine compartment, near engine controller. Engine diagnostic connector is a 6-terminal connector.

Perform TEST 6D before proceeding.

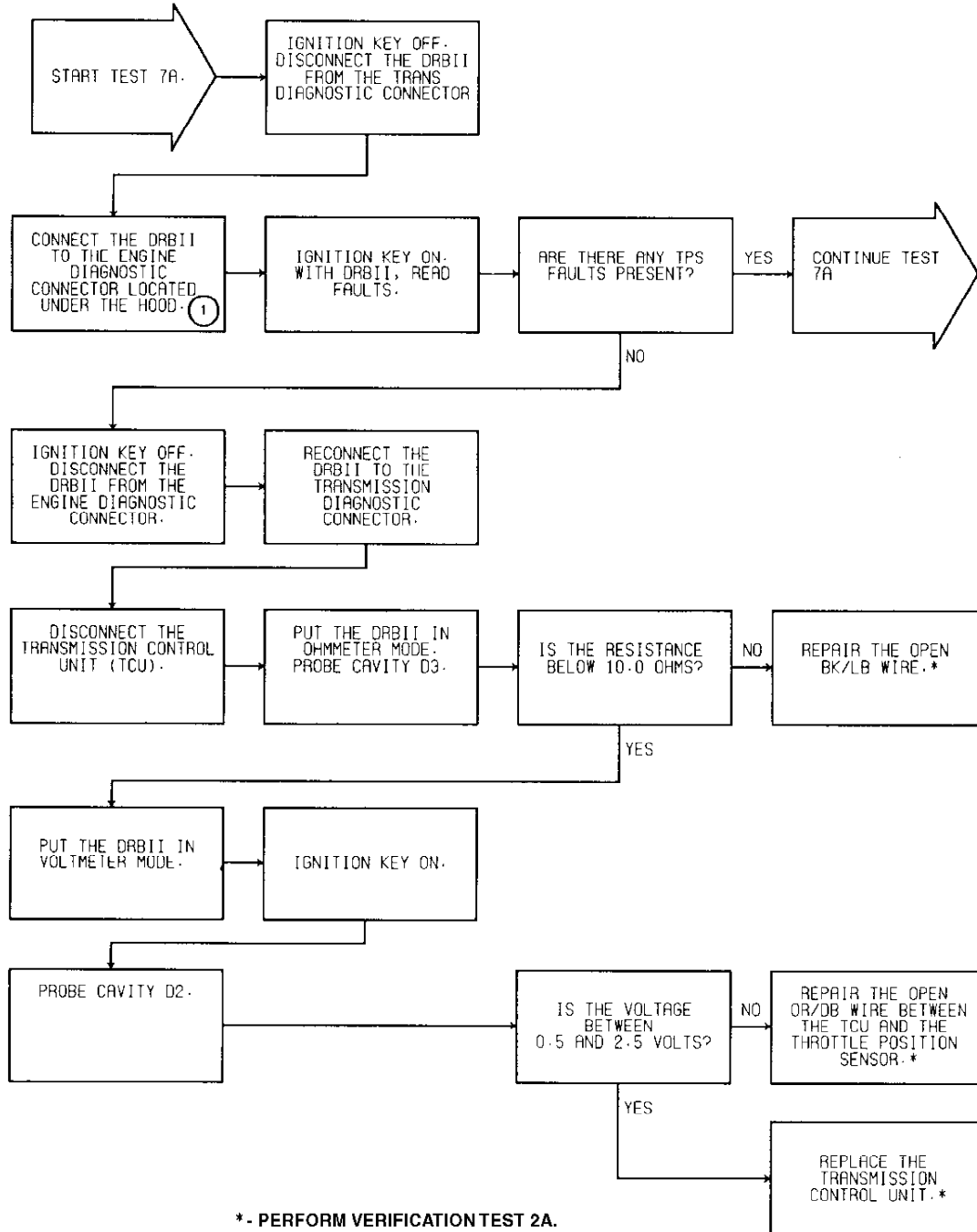

① - On XJ models, engine diagnostic connector is located at left side of engine compartment, near engine controller.

94138438
Fig. 91: Test 7A - Code 705, Flow Chart (1 of 2)

ENGINE CONTROLLER

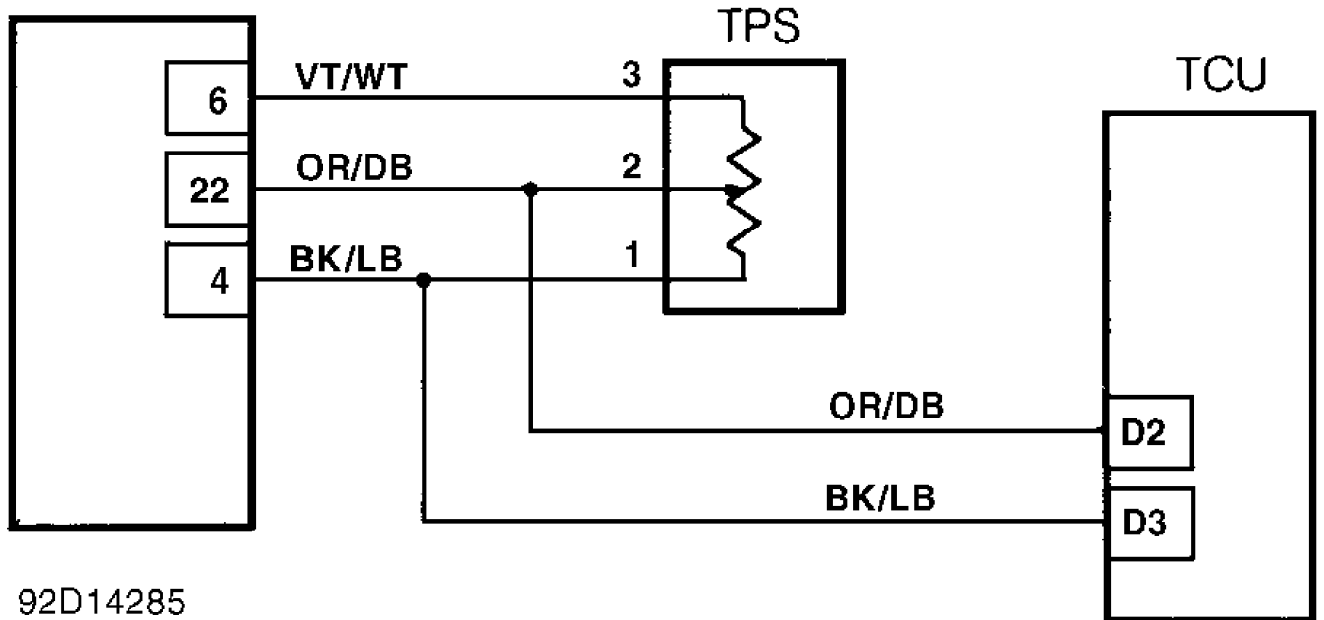

92D14285

Fig. 92: Test 7A - Code 705, Schematic

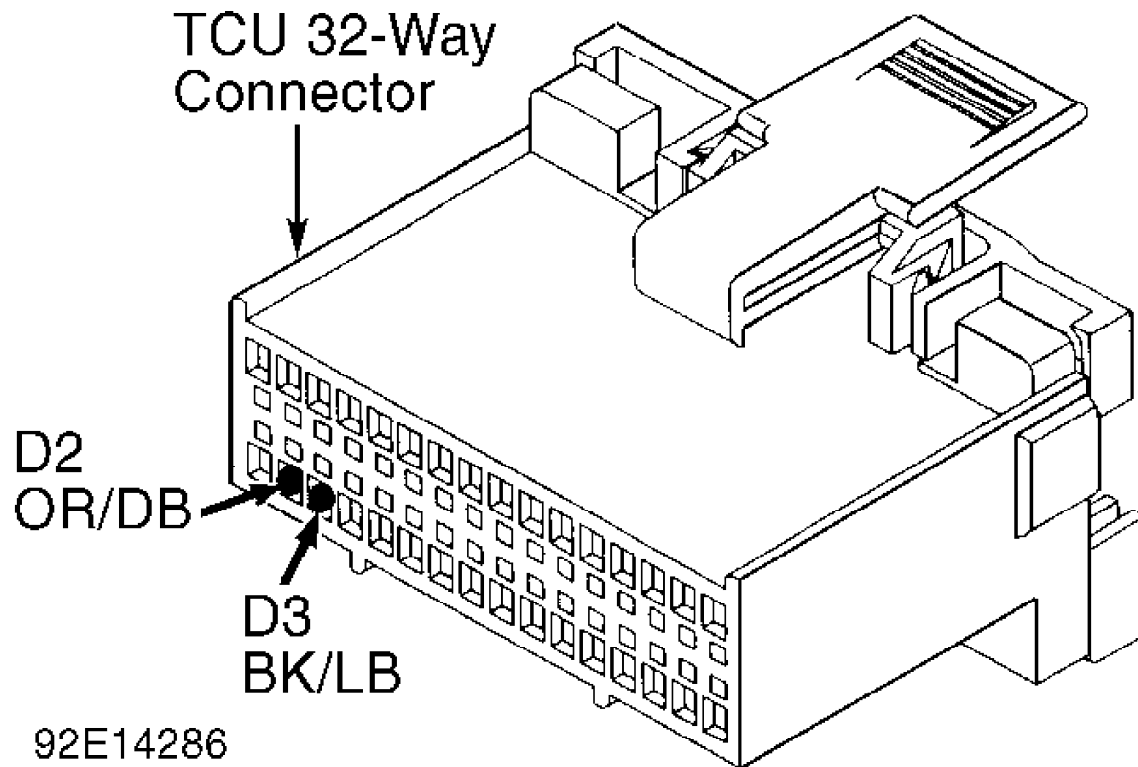

92E14286

Fig. 93: Test 7A - TCU 32-Way Connector (Cavities D2 & D3)

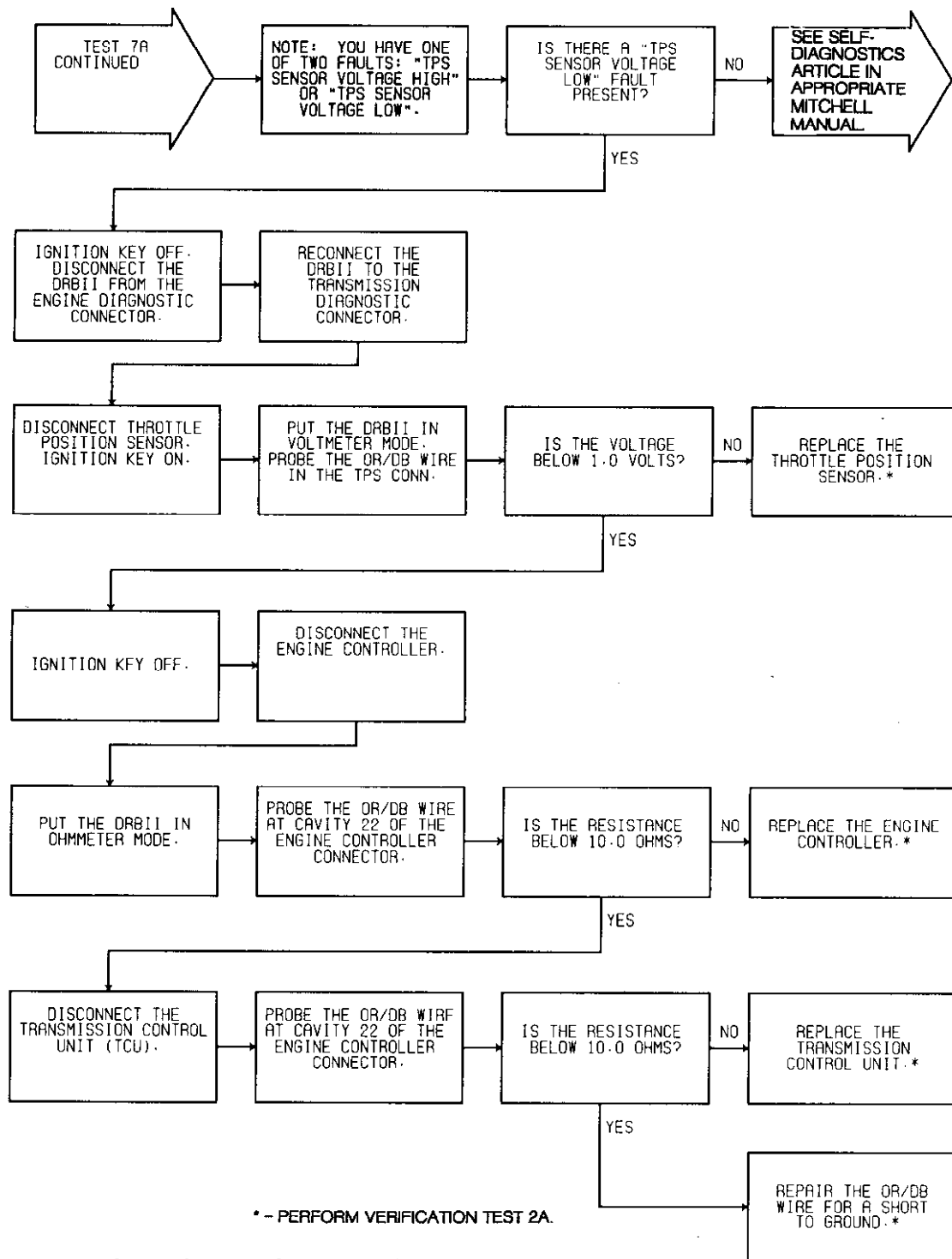

NOTE: See TEST 7A (1 OF 2) for wiring diagram.

92F14287

Fig. 94: Test 7A - Code 705, Flow Chart (2 of 2)

ENGINE CONTROLLER

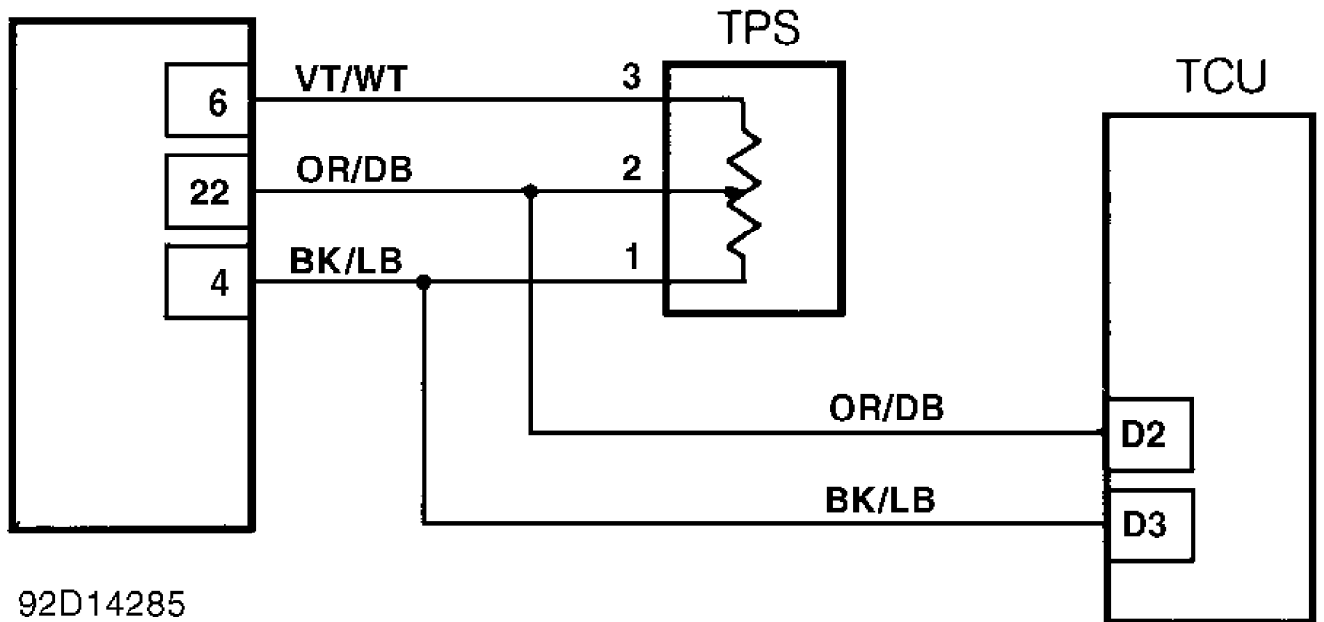

92D14285

Fig. 95: Test 7A - Code 705, Schematic

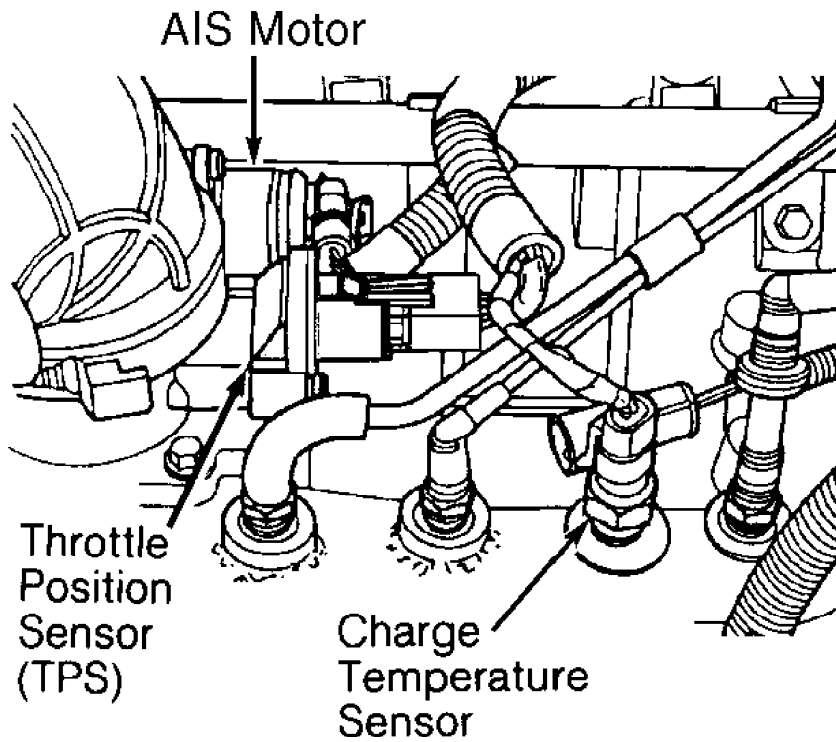

92G14288

Fig. 96: Test 7A - Location of Throttle Position Sensor (TPS)

Throttle Position Sensor Connector

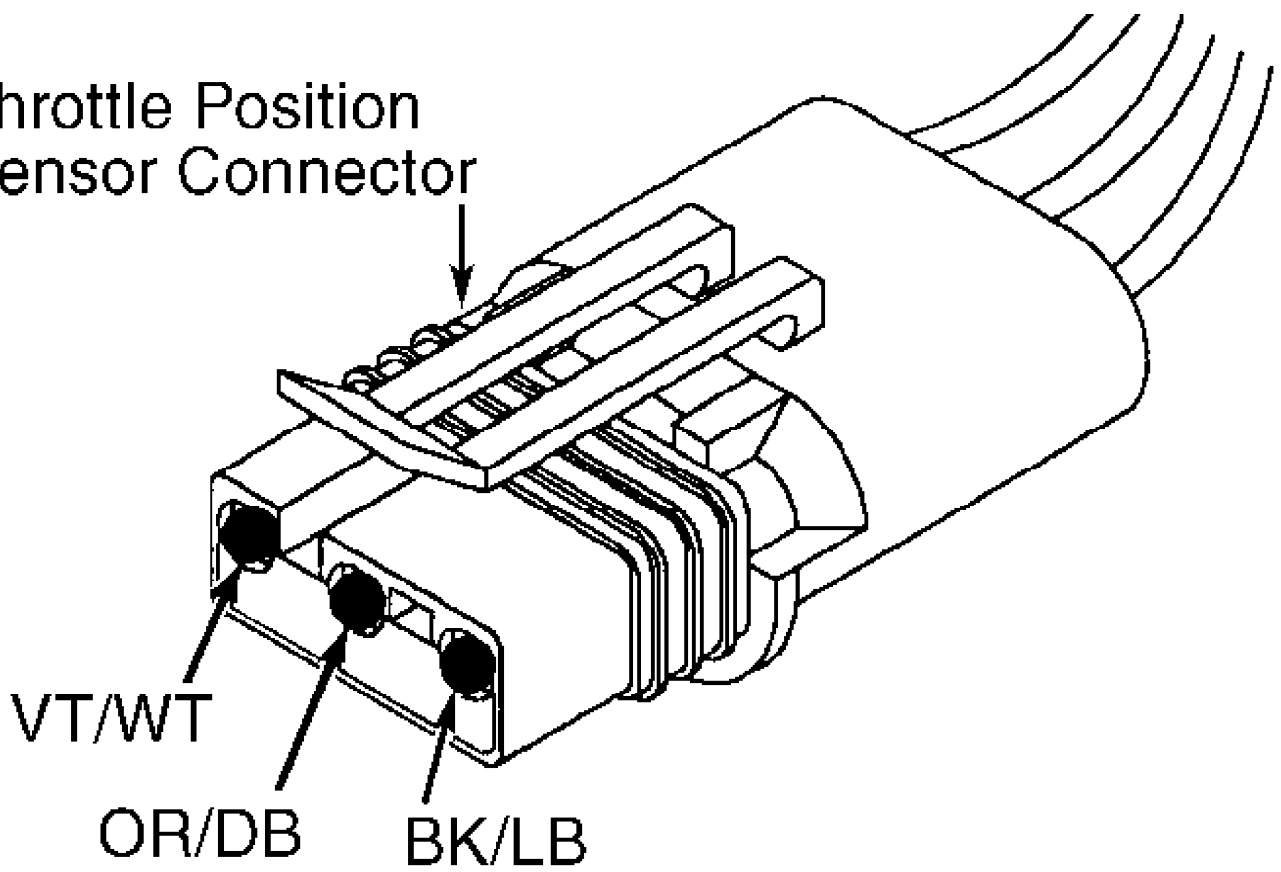

92H14289

Fig. 97: Test 7A - Code 705, View of TPS Connector

XJ BODY

Engine
Controller
Connector

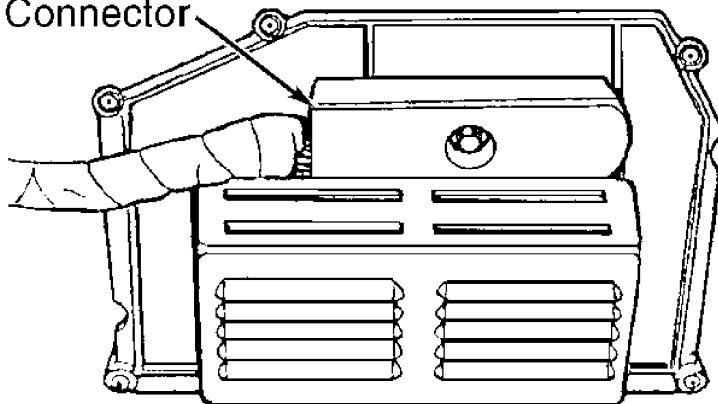

92A14290

Fig. 98: Test 7A - Location of Engine Control Connector (Cherokee)

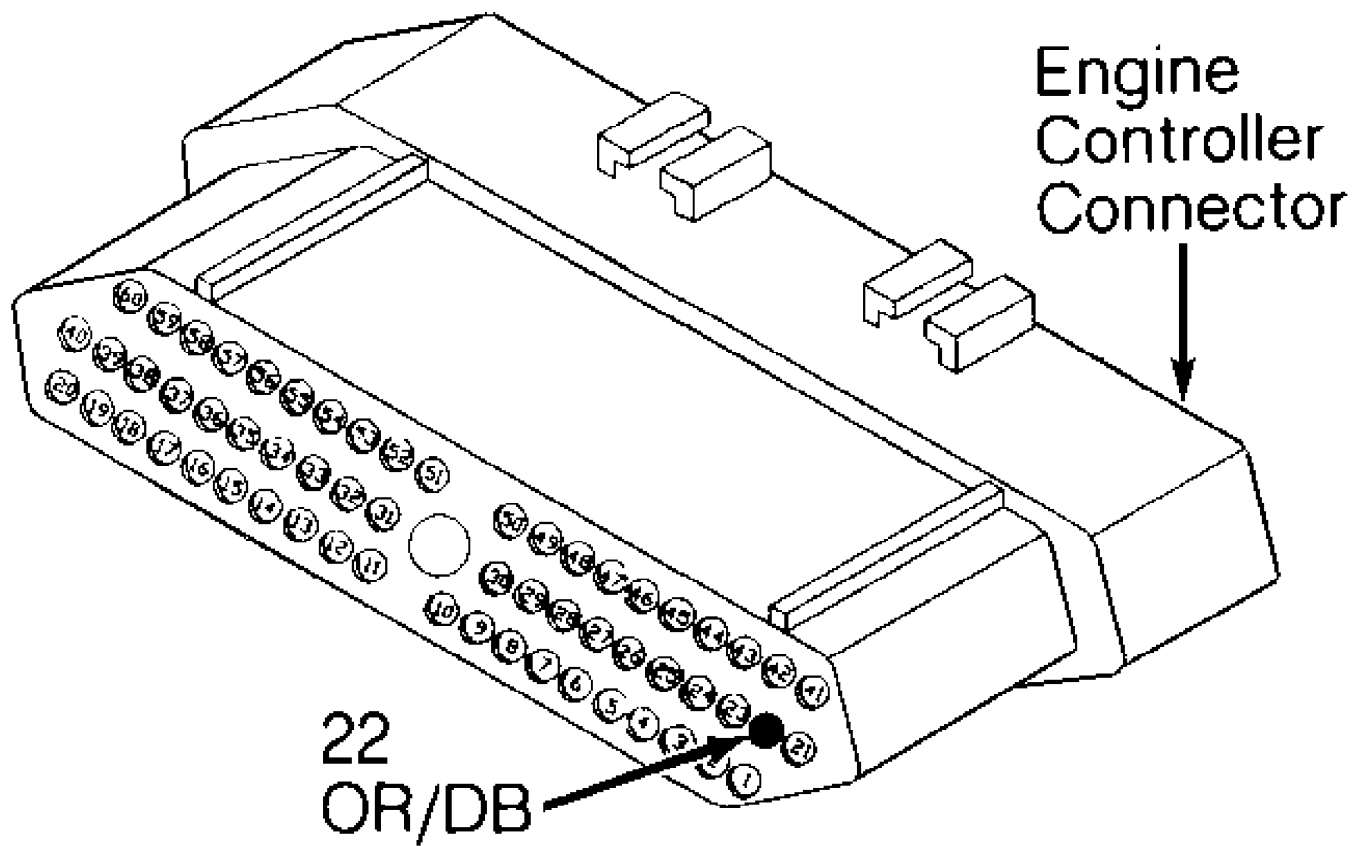

92C14292

Fig. 99: Test 7A - View of Engine Control Connector (Cavity 22)

TEST 8A - CODE 706 - BRAKE SWITCH CIRCUIT

NOTE: Perform TEST 1A - VERIFICATION OF COMPLAINT before proceeding.

Perform TEST 1A before proceeding.

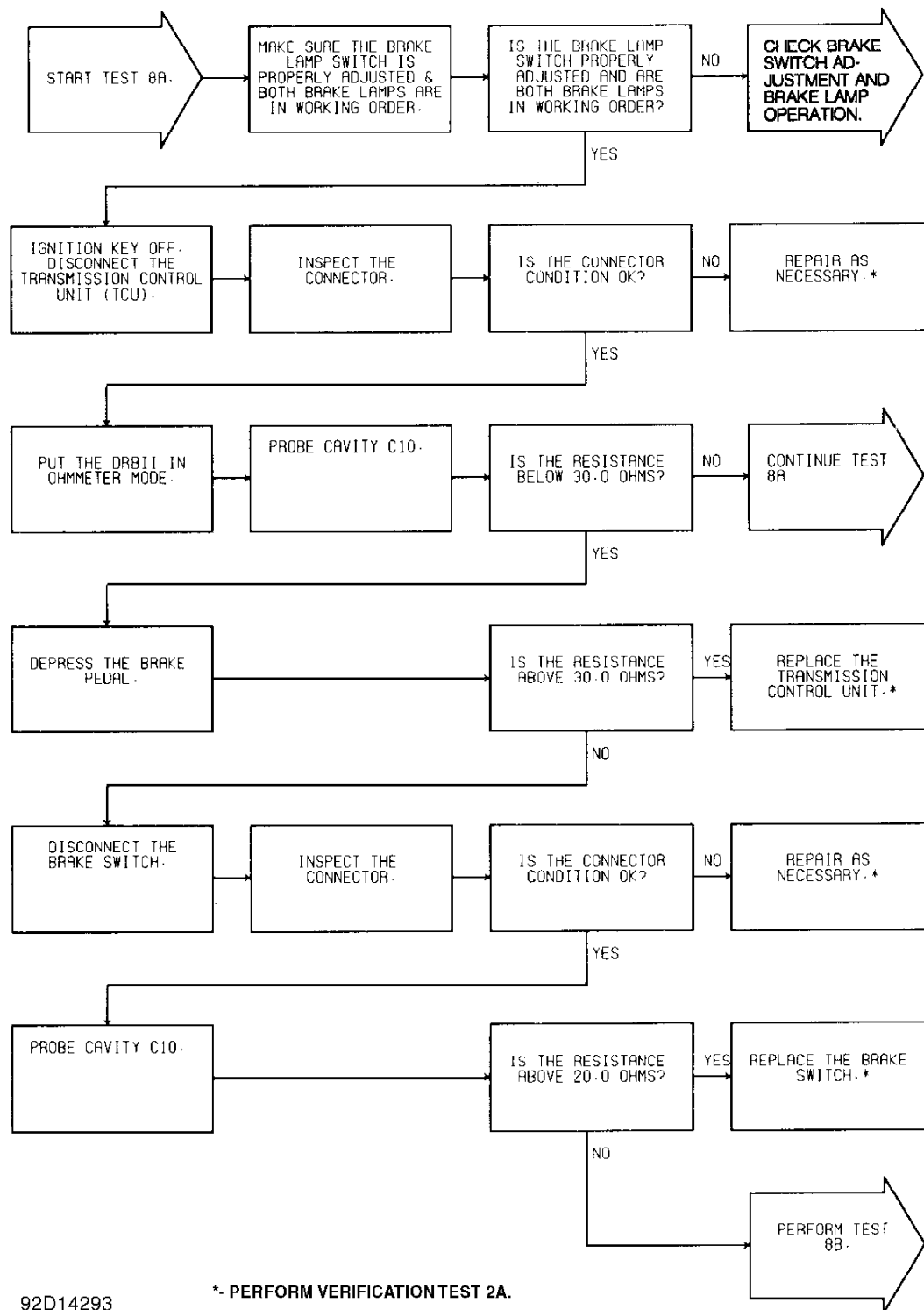

92D14293

*- PERFORM VERIFICATION TEST 2A.

Fig. 100: Test 8A - Code 706, Flow Chart

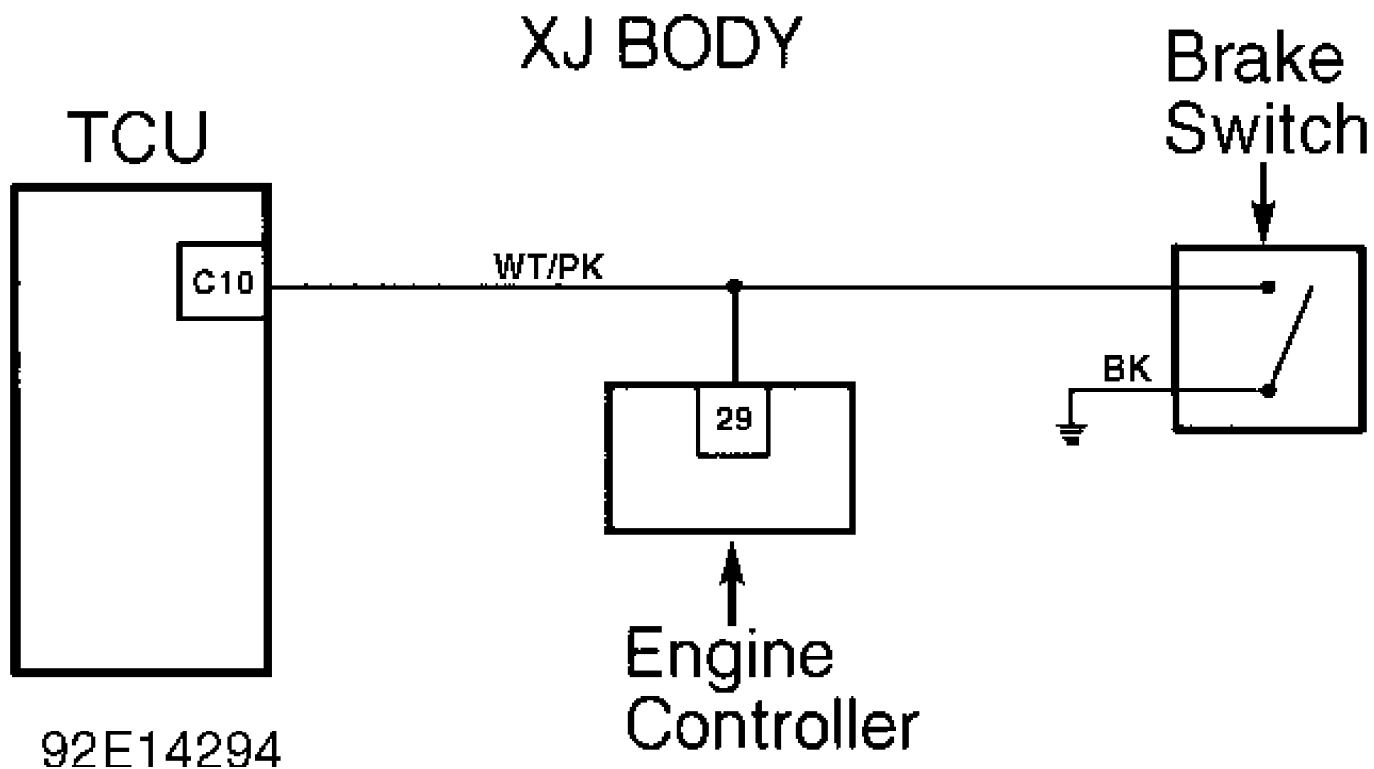

Fig. 101: Test 8A - Code 706, Schematic (Cherokee)

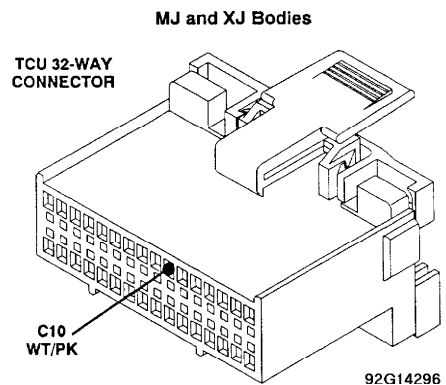

Fig. 102: Test 8A - TCU 32-Way Connector (Cavity 10, Cherokee)

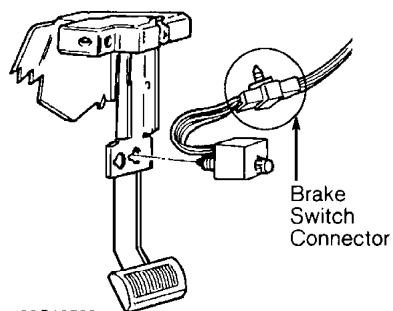

Fig. 103: Test 8A - Location of Brake Switch Connector

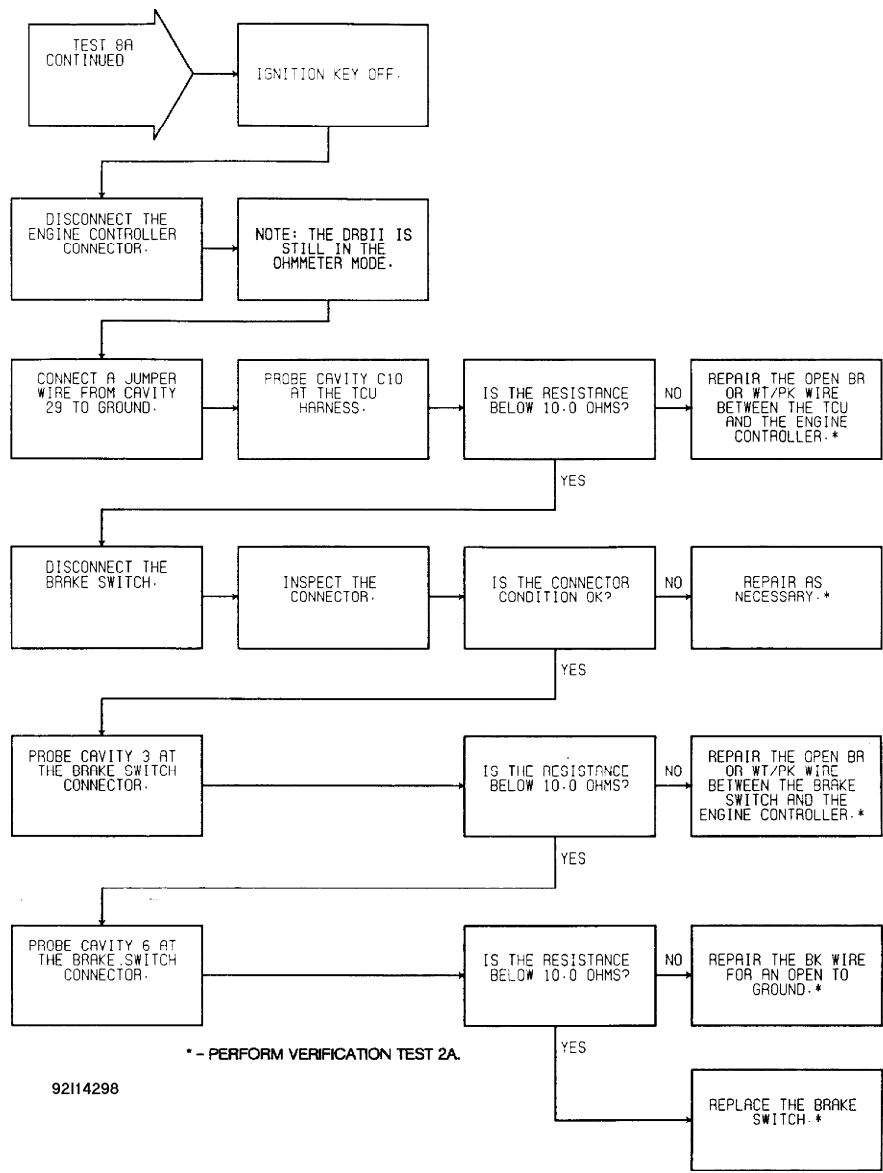

Fig. 104: Test 8A - Code 706, Flow Chart

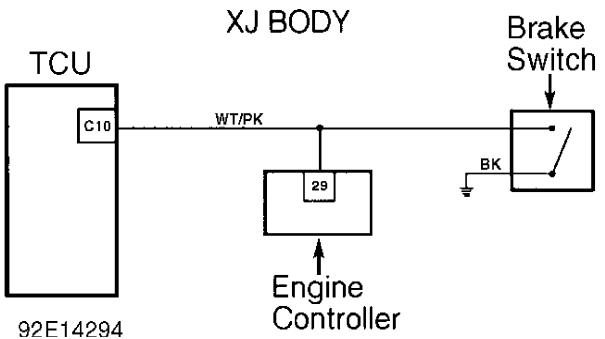
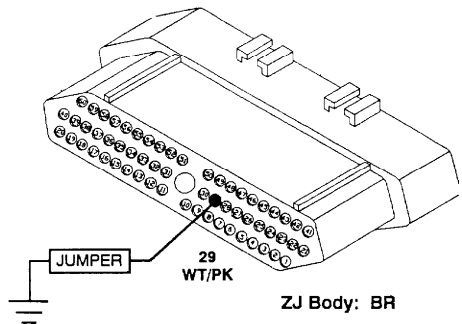

Fig. 105: Test 8A - Code 706, Schematic (Cherokee)

MJ and XJ Bodies
ENGINE CONTROLLER CONNECTOR



92J14299

Fig. 106: Test 8A - View of Engine Controller Connector (Cavity 29)

MJ and XJ Bodies

TCU 32-WAY CONNECTOR

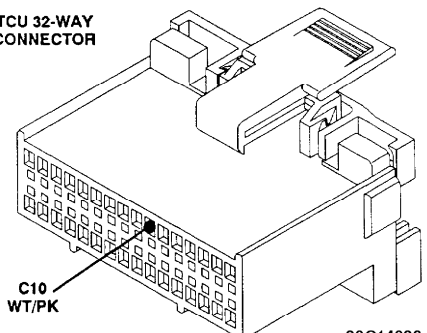

92G14296

Fig. 107: Test 8A - TCU 32-Way Connector (Cavity 10, Cherokee)

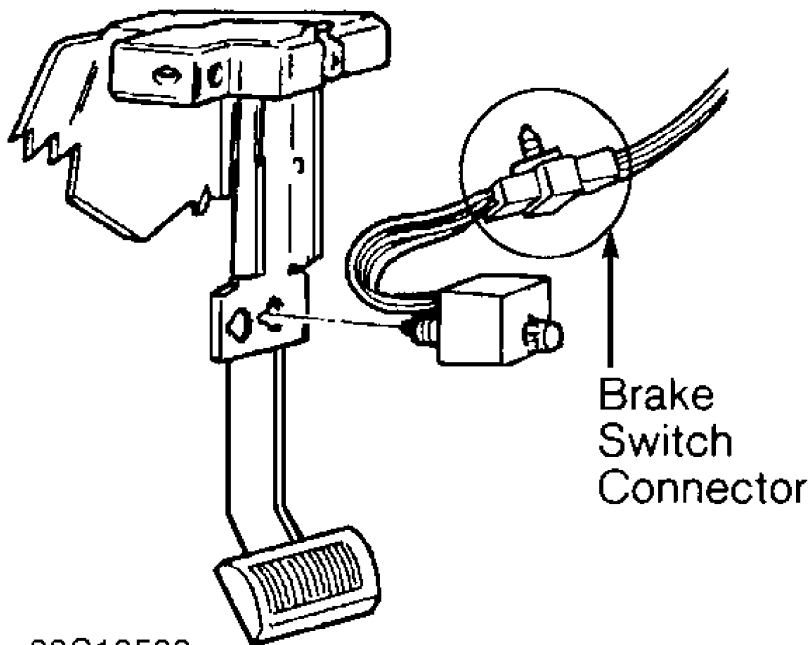

92C13583

Fig. 108: Test 8A - Location of Brake Switch Connector

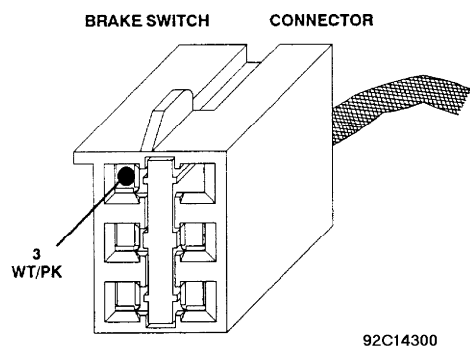

ZJ Body: BR
 Fig. 109: Test 8A - View of Brake Switch Connector (Cavity 3)

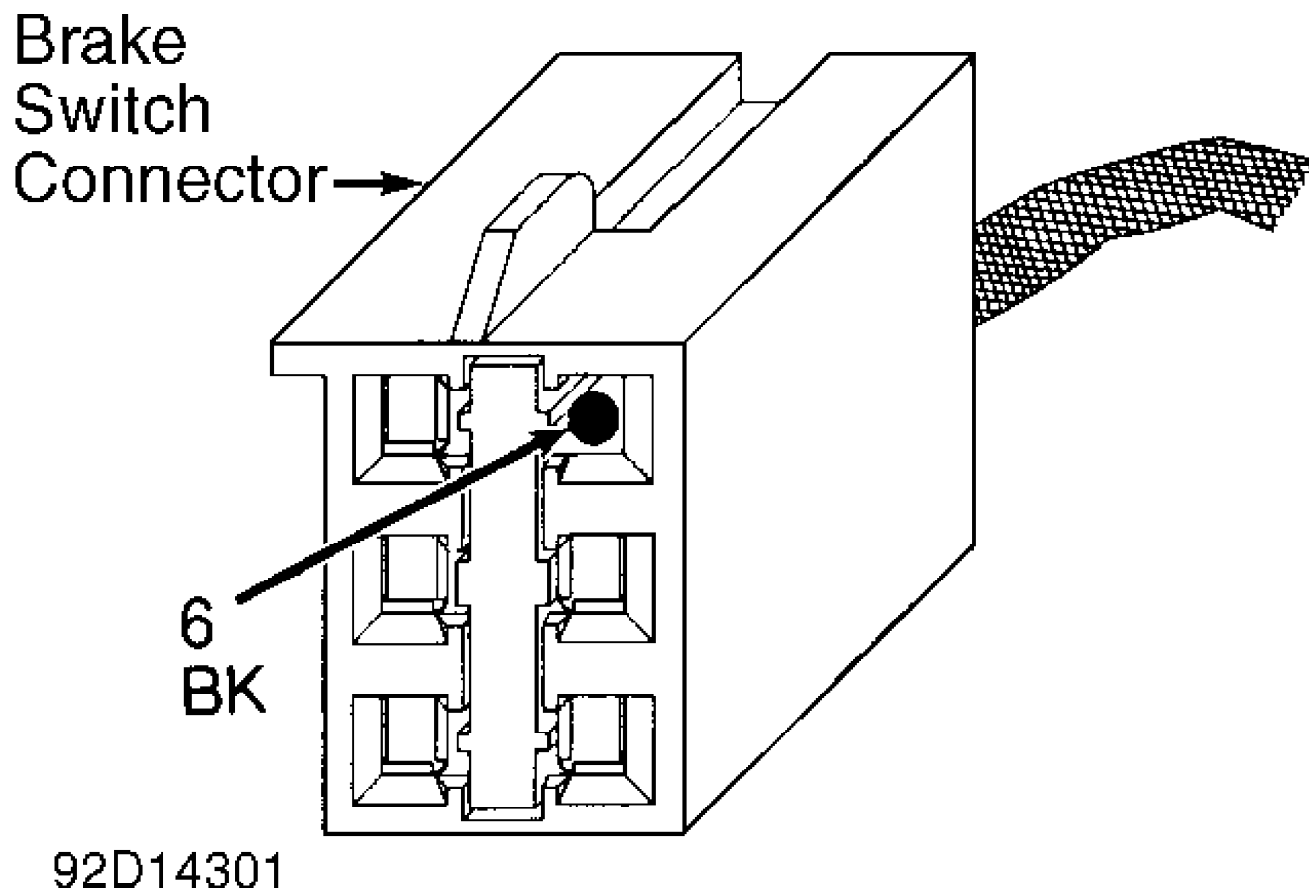
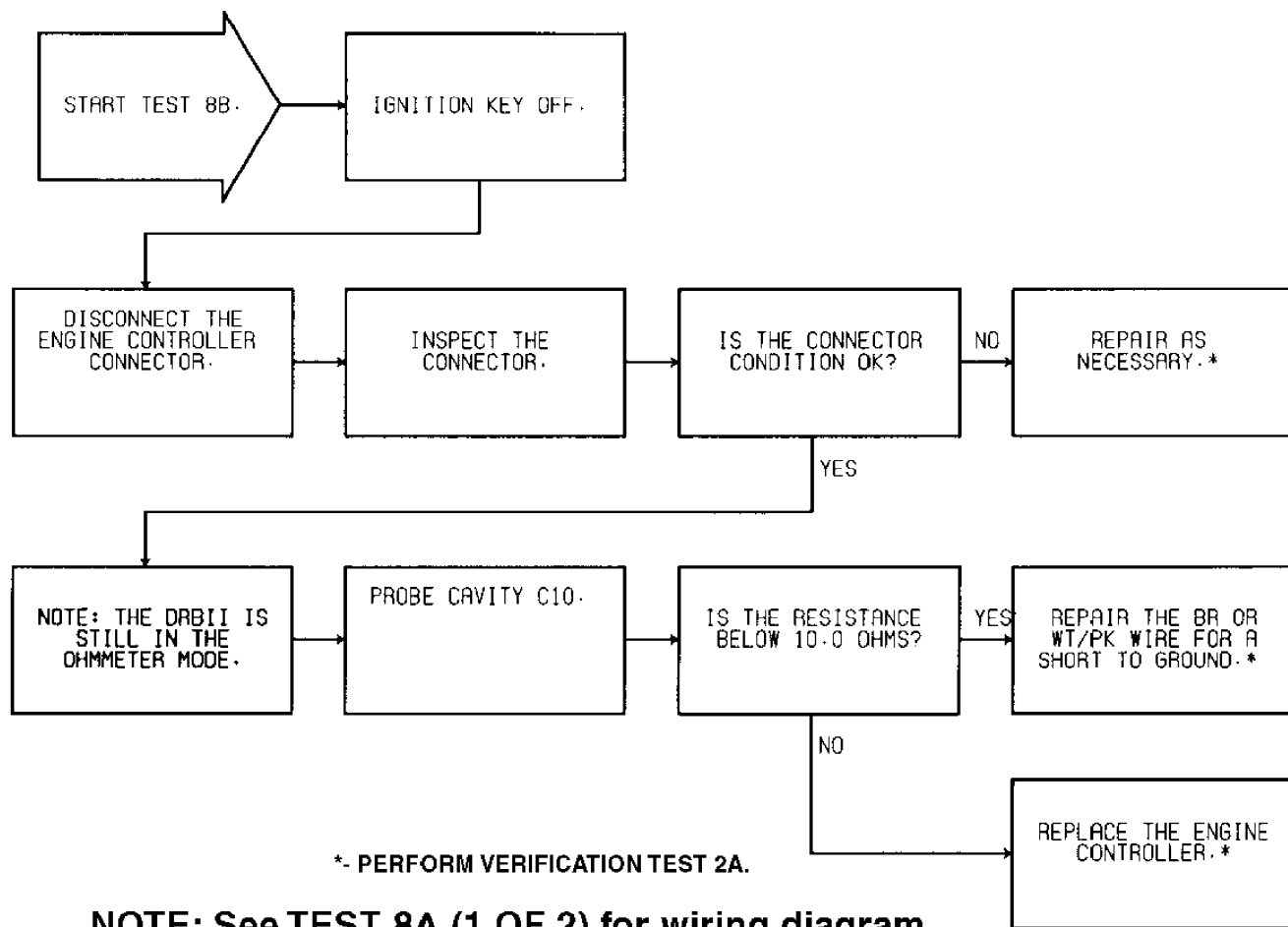

Fig. 110: Test 8A - View of Brake Switch Connector (Cavity 6)

TEST 8B - CODE 706 - BRAKE SWITCH CIRCUIT

NOTE: Perform TEST 8A - CODE 706 - BRAKE SWITCH CIRCUIT before proceeding.

Perform TEST 8A before proceeding.



92E14302

Fig. 111: Test 8B - Code 706, Flow Chart

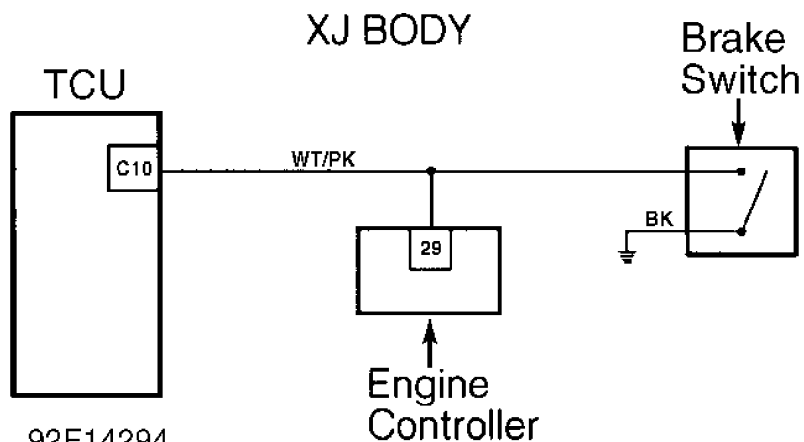

92E14294

Fig. 112: Test 8B - Code 706, Schematic (Cherokee)

XJ BODY

Engine
Controller
Connector

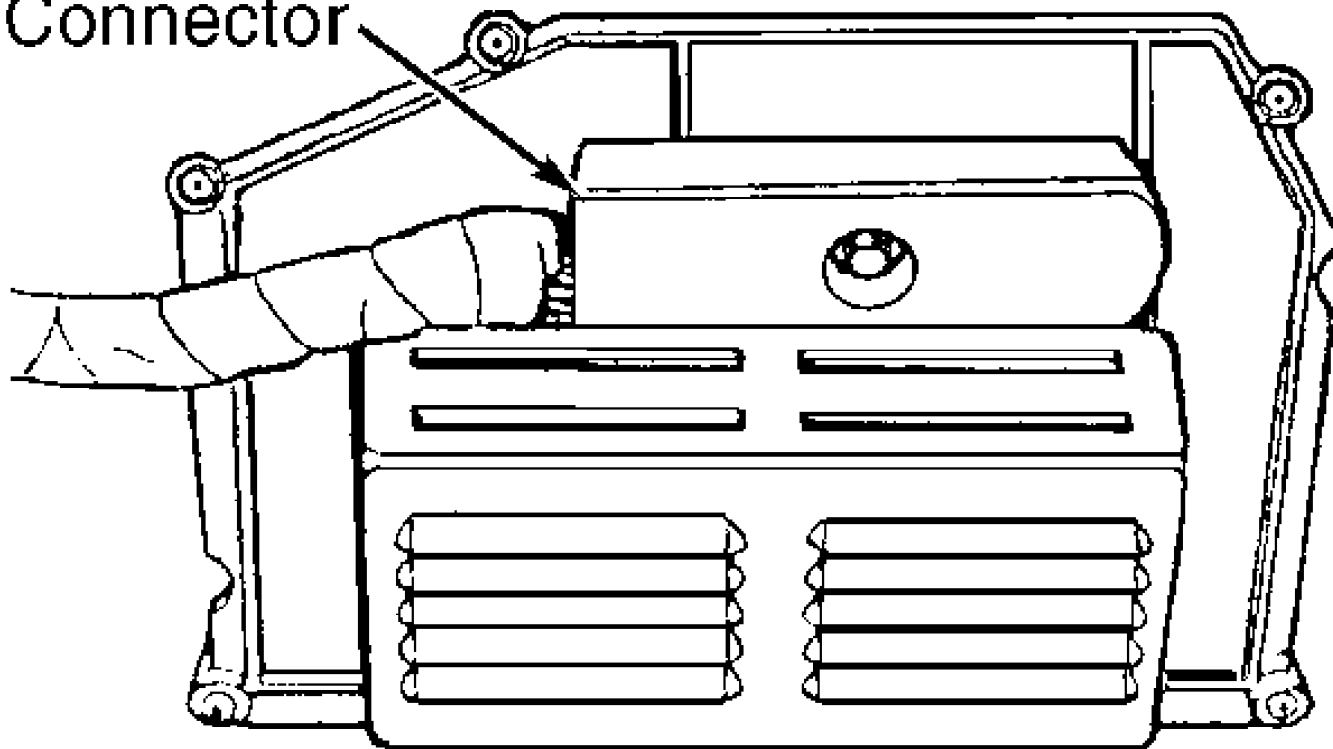

92A14290

Fig. 113: Test 7A - Location of Engine Control Connector (Cherokee)

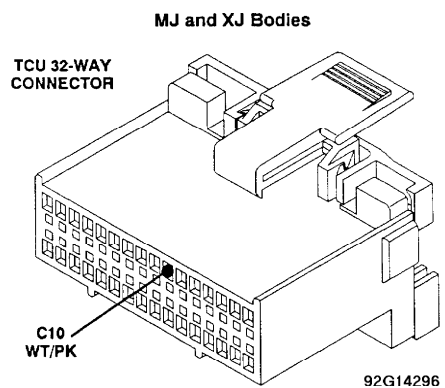

Fig. 114: Test 8B - TCU 32-Way Connector (Cavity 10, Cherokee)

TEST 9A - WRONG TCU

NOTE: Perform TEST 1A - VERIFICATION OF COMPLAINT before proceeding.

NOTE: The AW-4 is used only on 4.0L. In earlier years, it was

used with 2.5L

The DRB-II has determined that the wrong Transmission Control Unit (TCU) has been installed in the vehicle. There are two transmission control units available for the Jeep AW4 transmission. One is for the 4-cylinder 2.5L engine and the other is for the 6-cylinder 4.0L engine.

1) using the DRB-II, read MODULE INFO. See HELP 1 for assistance.

2) Determine what vehicle should be in the vehicle.

- * 2.5L Engine: TCU 02 (Used in earlier years only)
- * 4.0L Engine: TCU 01 (1993-94)

3) If the wrong transmission control unit is installed, the vehicle shift points will be slightly different (the 2.5L engine TCU has higher shift points).

TEST 10A - TESTING FOR INTERMITTENT SPEED SENSOR

NOTE: Perform TEST 1A - VERIFICATION OF COMPLAINT before proceeding.

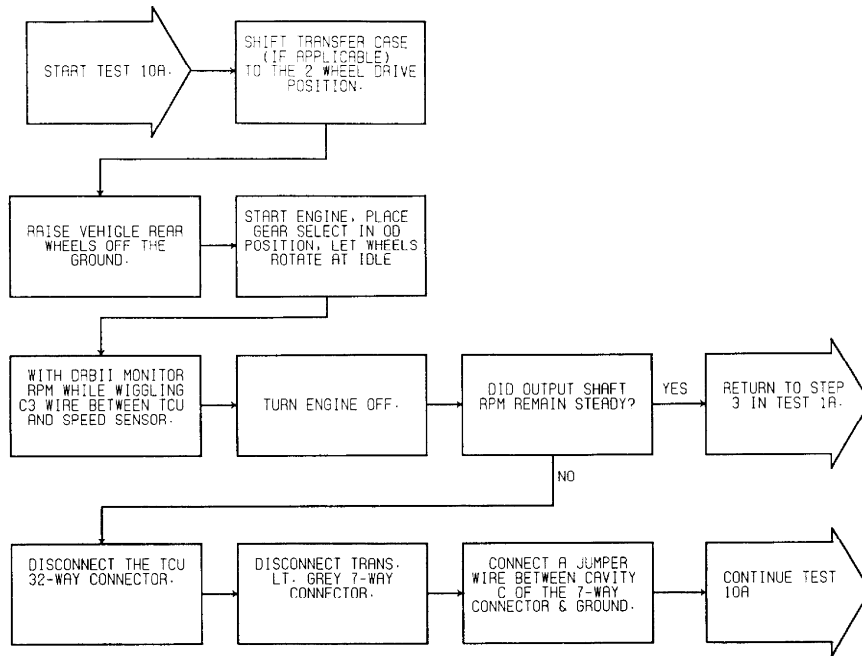

* - PERFORM VERIFICATION TEST 2A.

92G14304

Fig. 115: Test 10A - Flow Chart (1 of 2)

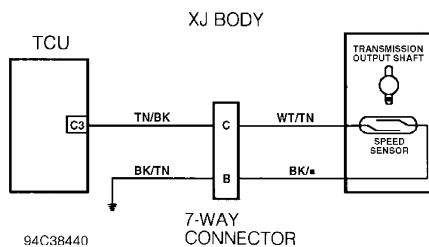

94C38440

Fig. 116: Test 10A - Schematic (Cherokee)

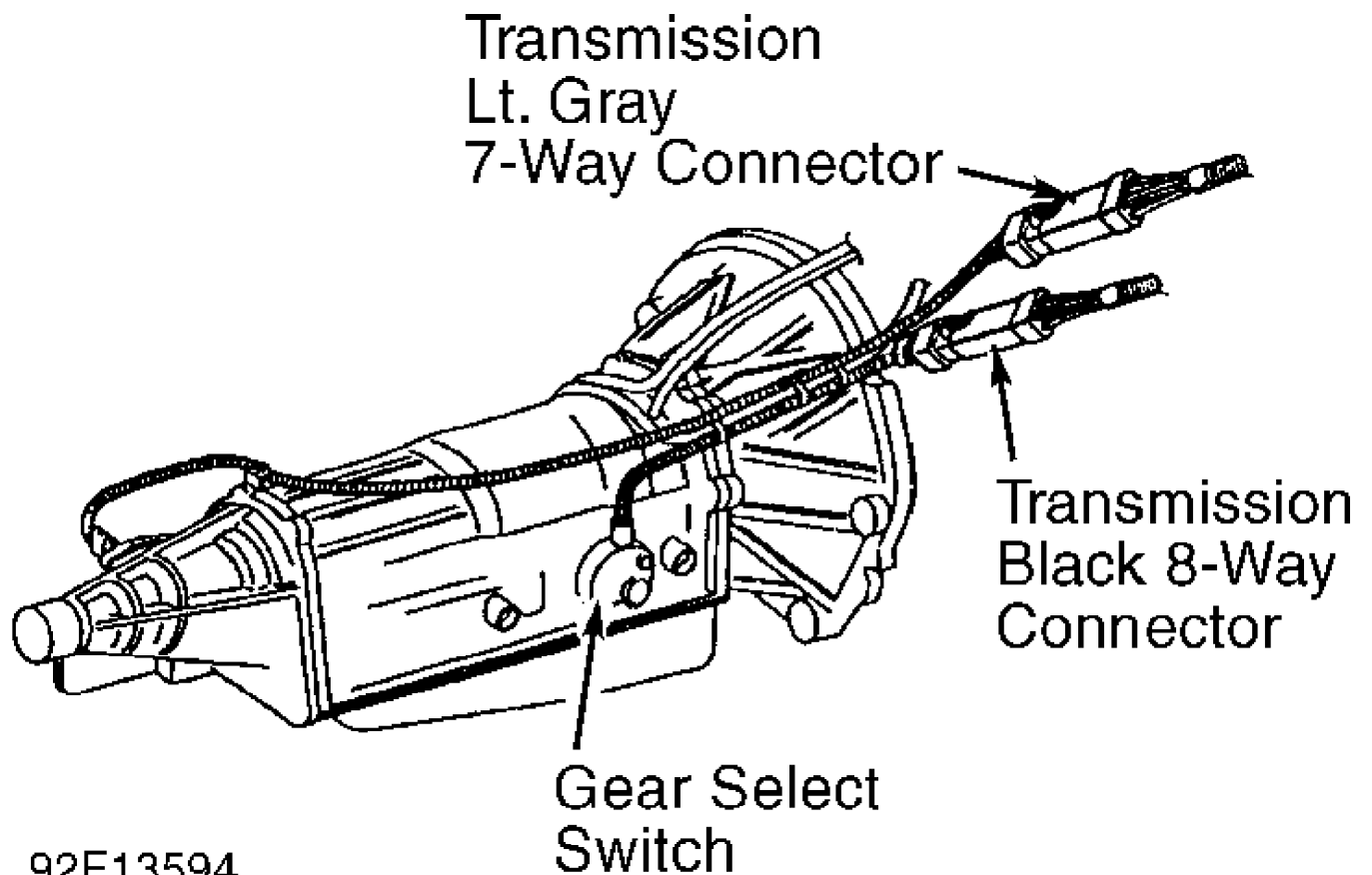
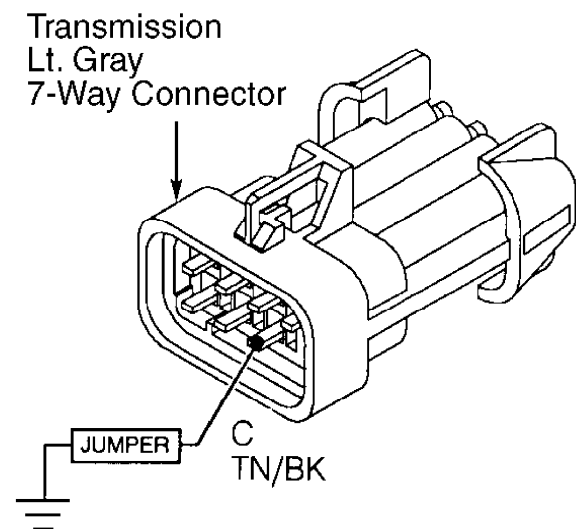

Fig. 117: Test 10A - Location of Transmission Connectors

XJ BODY



94D38441

Fig. 118: Test 10A - View of 7-Way Connector (Cherokee)

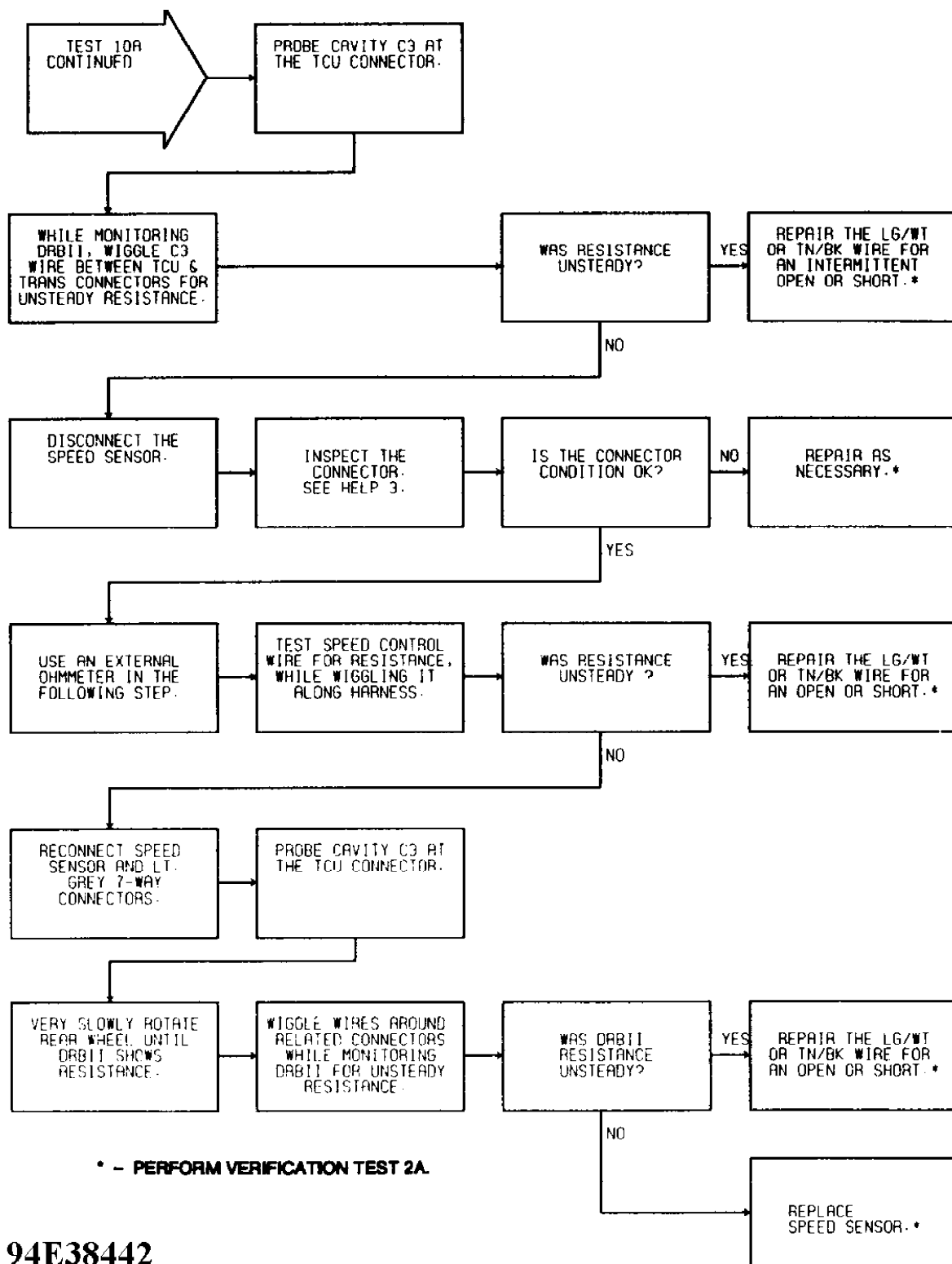

94E38442

Fig. 119: Test 10A - Flow Chart (2 of 2)

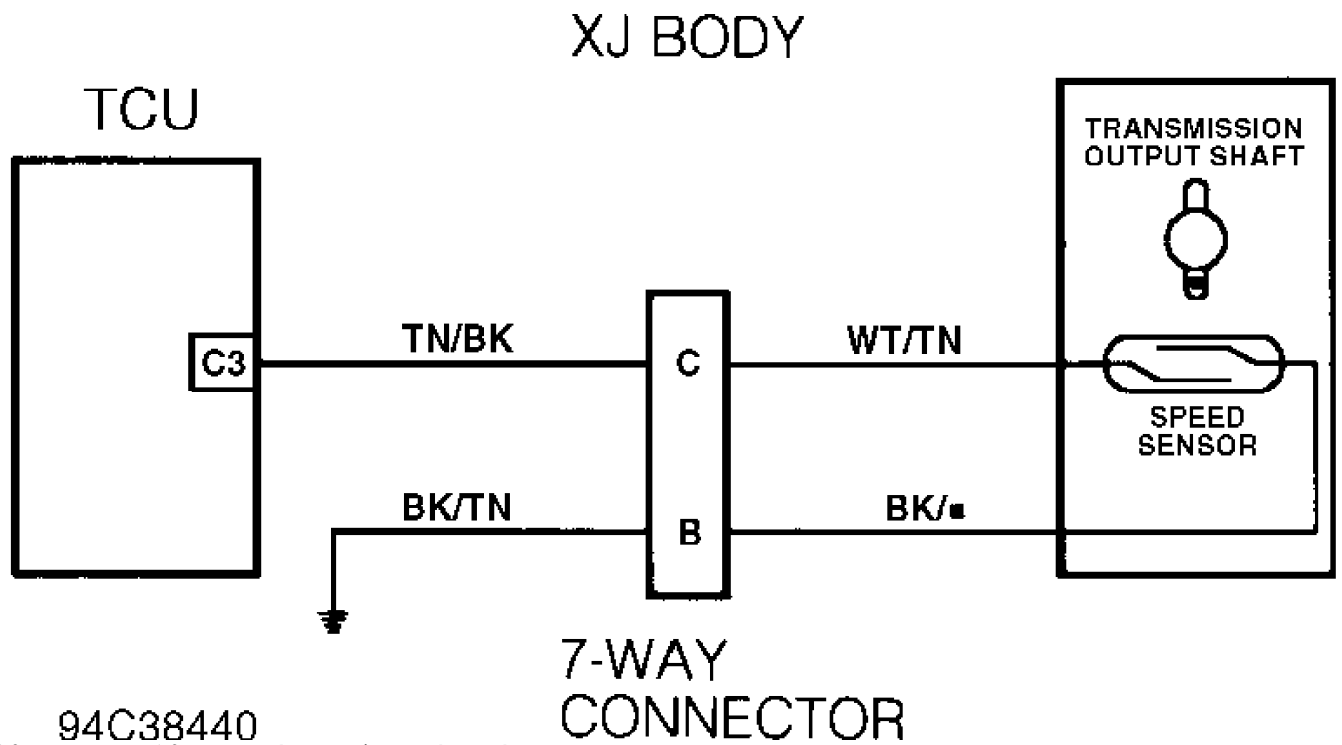

Fig. 120: Test 10A - Schematic (Cherokee)

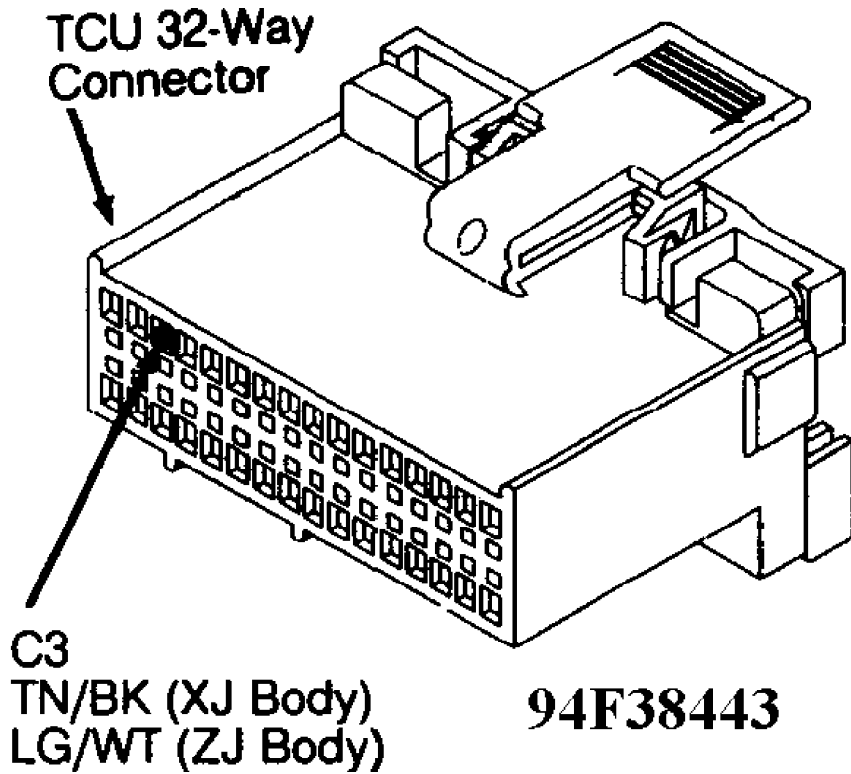

Fig. 121: Test 10A - TCU 32-Way Connector (Cavity 3)

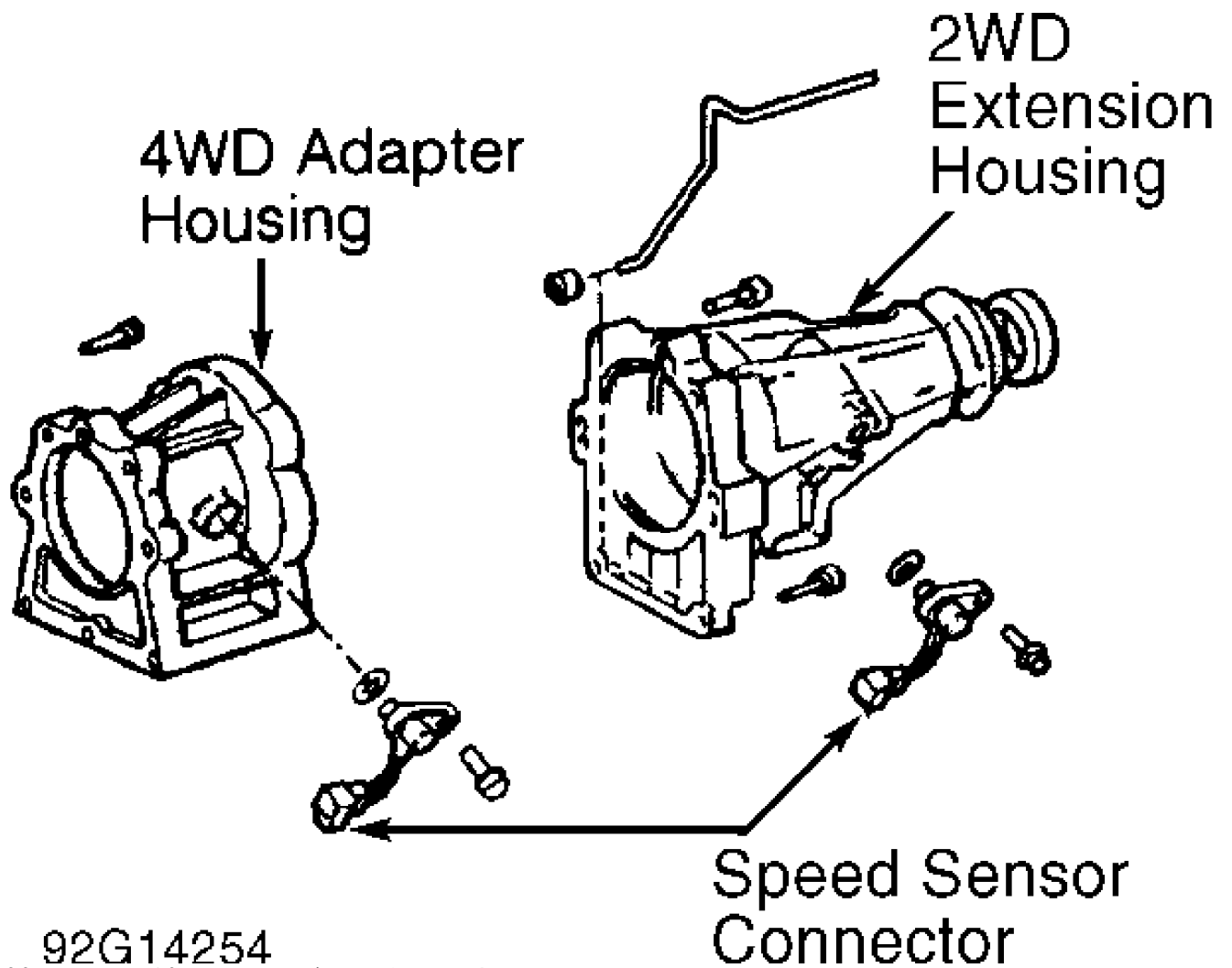

Fig. 122: Test 10A - Location of Speed Sensor Connector

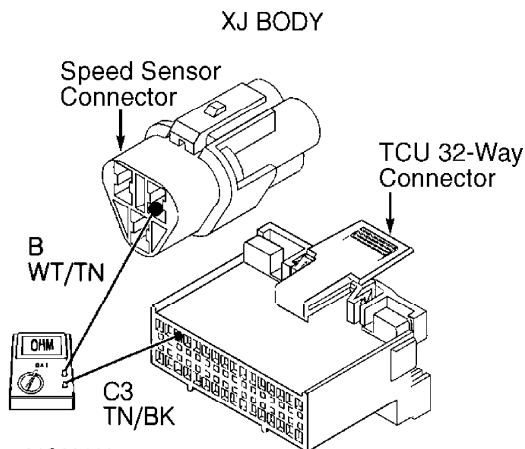

Fig. 123: Test 10A - Testing Speed Sensor (Cherokee)

WIRING DIAGRAMS

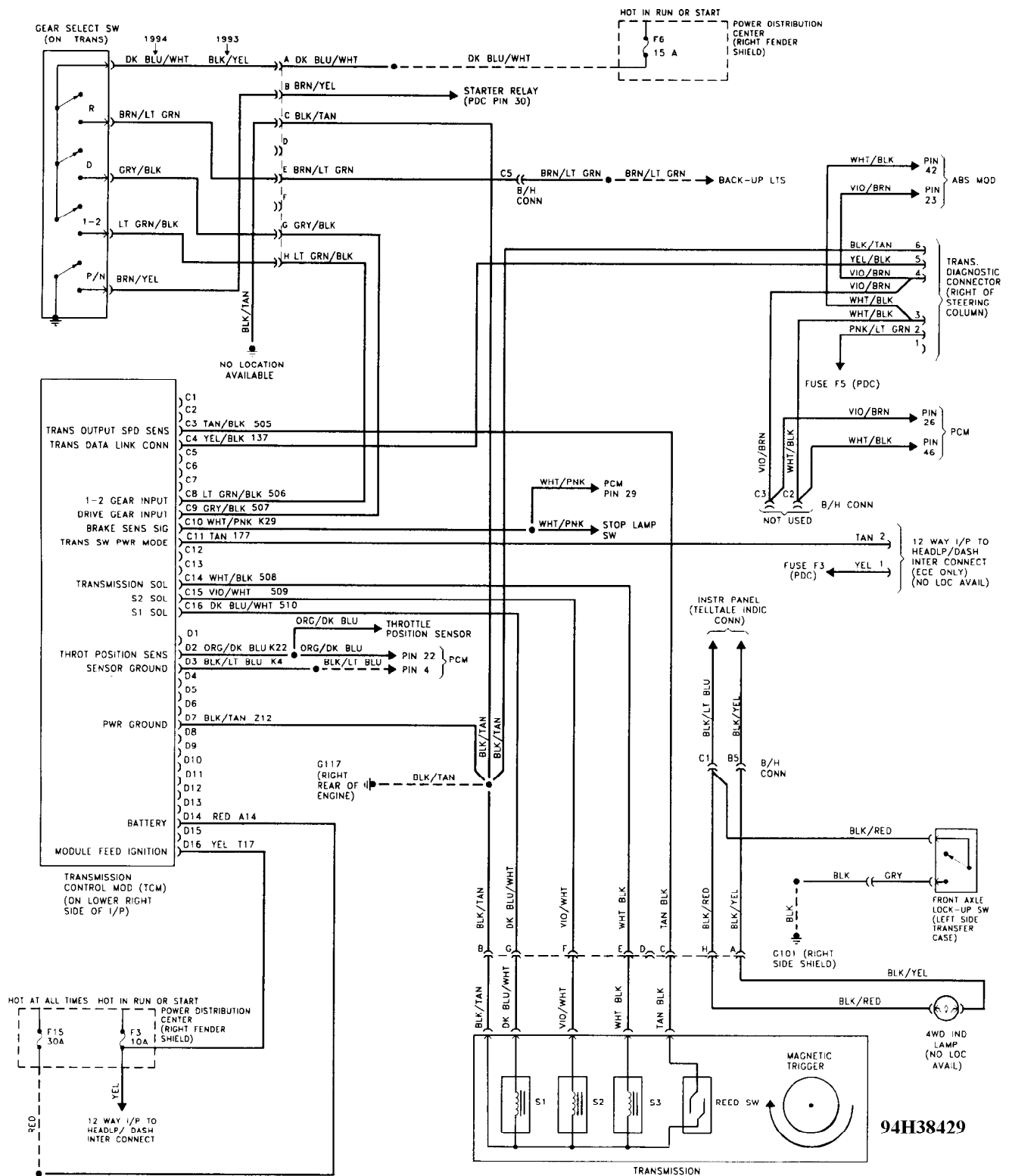
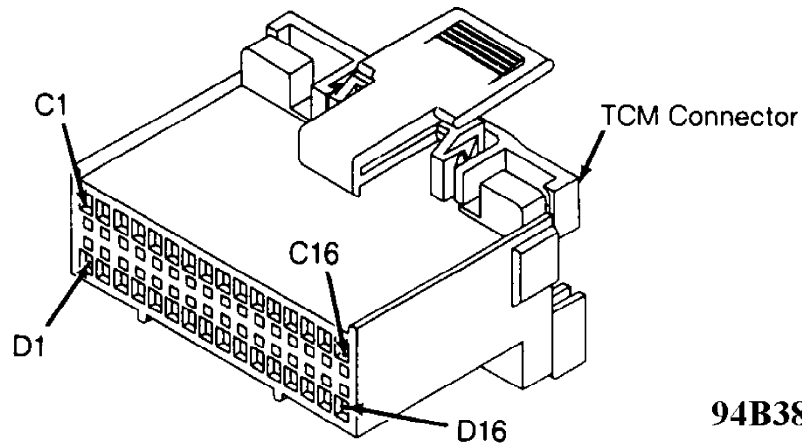

Fig. 124: Transmission Wiring Diagram (Cherokee)



94B38431

CHEROKEE

CAV ...	CIRCUIT	FUNCTION
C1-C2	Not Used
C3 505 TN/BK.....	Trans Speed Sensor
C4 137 YL/BK	Auto Trans Diagnostic
C5-C7	Not Used
C8 506 LG/BK.....	Low (1-2) Input
C9 507 GY/BK	Drive (3) Input
C10 K29 WT/PK	Brake Input
C11	Not Used
C12-C13	Not Used
C14 508 WT/BK.....	S3 Solenoid (Converter Lockup)
C15 509 VT/WT	S2 Solenoid
C16 510 DB/WT	S1 Solenoid
D1	Not Used
D2 K22 OR/DB	Throttle Position Sensor
D3 K4 BK/LB.....	TPS Signal Ground
D4-D6	Not Used
D7 Z12 BK/TN	Power Ground
D8-D13	Not Used
D14 A14 RD.....	Battery
D15	Not Used
D16 T17 YL	Ignition (Run/On)

GRAND CHEROKEE

CAV...	CIRCUIT	FUNCTION
C1-C2	Not Used
C3 T14 LG/WT	Trans Speed Sensor
C4 D82 BK/YL	Auto Trans Diagnostic
C5-C7	Not Used
C8 T25 LG	Low (1-2) Input
C9 T50 DG	Drive (3) Input
C10 L53 BR.....	Brake Input
C11-C13	Not Used
C14 T20 LB/BR	S3 Solenoid (Converter Lockup)
C15 T59 PK.....	S2 Solenoid
C16 T60 BR/YL	S1 Solenoid
D1	Not Used
D2 K22 OR/DB	Throttle Position Sensor
D3 K4 BK/LB	TPS Signal Ground
D4-D6	Not Used
D7 Z1 BK.....	Power Ground
D8-D13	Not Used
D14 A14 RD/WT	Battery
D15	Not Used
D16 F86 LB/RD	Ignition (Run/On)

Fig. 125: TCM Connector Terminals I.D., Circuits & Functions
Courtesy of Chrysler Corp.

REMOVAL & INSTALLATION

BRAKE SWITCH R & I

Removal

Remove lower steering column cover or trim panels for access to brake switch (if necessary). Disconnect brake switch electrical connector. Thread brake switch from retainer and remove.

Installation

1) Install brake switch in retainer. Reconnect brake switch electrical connector.

2) To check brake switch adjustment, slightly depress brake pedal and note operation of brake switch plunger. Brake switch plunger should fully extend when brake pedal free play is taken up and brake application begins.

3) Clearance between brake switch plunger and brake pedal should be approximately 1/8". If clearance is not within specification, pull brake pedal rearward as far as possible.

4) Brake pedal should contact brake switch plunger, pushing brake switch backward in retainer to provide proper adjustment. Ensure brake lights operate.

5) Recheck clearance between brake switch plunger and brake pedal with brake pedal depressed and free play taken up. Reinstall lower steering column cover or trim panels.

NEUTRAL SAFETY SWITCH R & I

NOTE: Neutral safety switch may be referred to as park/neutral or gear select switch.

Removal

1) Apply parking brake. Raise and support vehicle. Disconnect electrical connector at neutral safety switch. Pry lock washer tabs away from retaining nut. See Fig. 126.

2) Remove retaining nut, lock washer and adjusting bolt. See Fig. 126. Remove neutral safety switch from manual valve shaft.

Installation

1) Disconnect shift control rod from transmission shift lever. Rotate transmission shift lever fully rearward and then forward 2 detents to Neutral position.

2) Install neutral safety switch on manual valve shaft. Install adjusting bolt but DO NOT tighten at this time.

3) Install lock washer and retaining nut. Tighten retaining nut to specification. See TORQUE SPECIFICATIONS. DO NOT bend over lock washer tabs at this time.

4) Ensure transmission is still in Neutral. Rotate neutral safety switch and align neutral standard line with vertical groove on manual valve shaft. See Fig. 126.

5) Tighten adjusting bolt to specification. See TORQUE SPECIFICATIONS at end of article. Bend lock washer tabs over. Reconnect shift control rod and electrical connector. Ensure vehicle starts in Park and Neutral only.

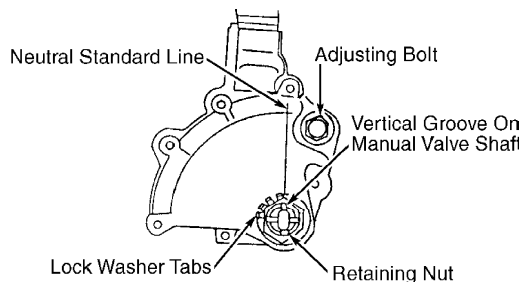

92G13454
Fig. 126: Installing Neutral Safety Switch
Courtesy of Chrysler Corp.

SPEED SENSOR R & I

Removal & Installation

1) Disconnect electrical connector at speed sensor located on adapter housing or extension housing. Remove bolt and speed sensor. Remove "O" ring from speed sensor.

2) To install, reverse removal procedure using NEW "O" ring. Tighten bolt to specification. See TORQUE SPECIFICATIONS.

THROTTLE POSITION SENSOR (TPS) R & I

Removal & Installation

1) Note location of TPS electrical connector. See Fig. 127. Disconnect electrical connector. Remove screws and TPS.

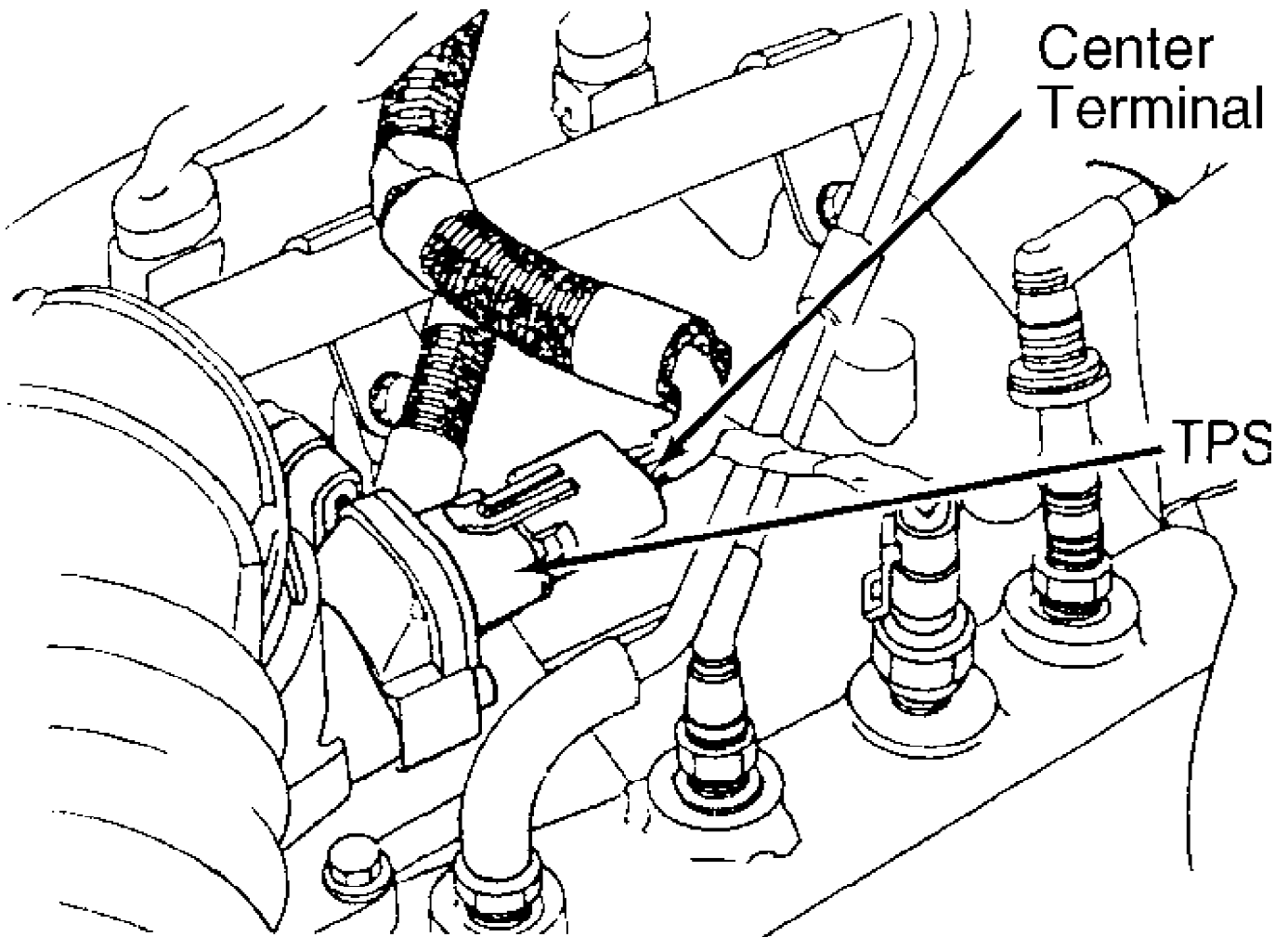

92113514

Fig. 127: Identifying TPS Electrical Connector
Courtesy of Chrysler Corp.

2) To install, reverse removal procedure. Ensure throttle shaft on throttle body engages socket tangs on TPS. See Fig. 128. Tighten screws. Manually operate throttle and ensure no binding exists. Reinstall electrical connector.

NOTE: TPS must be installed so it can be rotated a few degrees. If TPS cannot be rotated, reinstall TPS with end of throttle

shaft on other side of TPS socket tangs.

Socket Tangs

Throttle Shaft

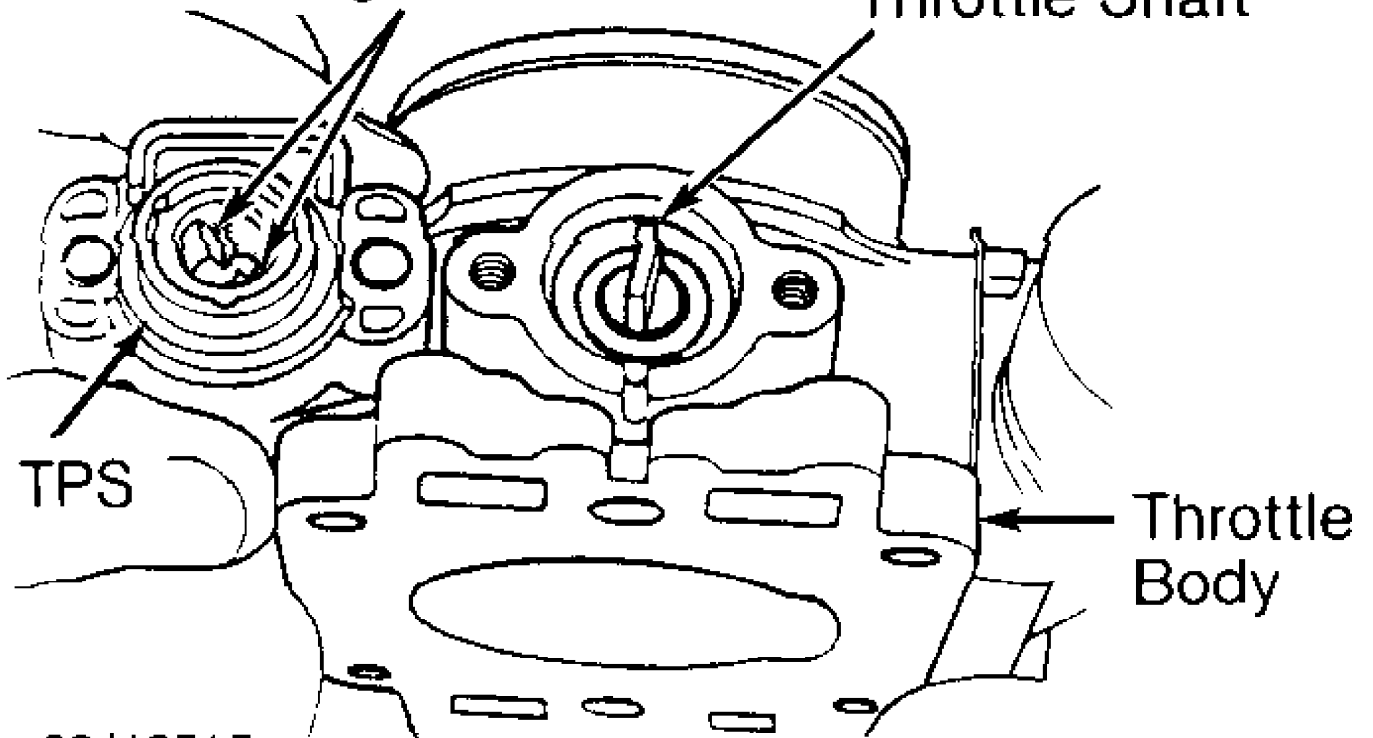

92J13515

Fig. 128: Installing Throttle Position Sensor (TPS)
Courtesy of Chrysler Corp.

TRANSMISSION CONTROL MODULE (TCM) R & I

Removal & Installation (Cherokee)

Ensure ignition is off. Disconnect electrical connector from TCM, located behind right side of instrument panel. See Fig. 129. Remove fastener and TCM from instrument panel. To install, reverse removal procedure.

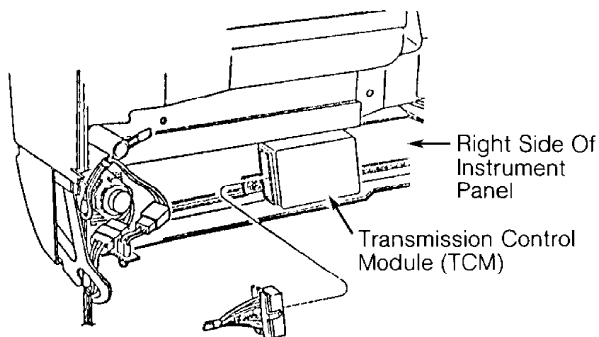

94F38401

Fig. 129: Transmission Control Module (TCM) I.D. (Cherokee)
Courtesy of Chrysler Corp.

VALVE BODY SOLENOID R & I

Removal

1) Raise and support vehicle. Remove drain plug and drain transmission fluid. Remove bolts and oil pan. Remove bolts, oil screen and gasket.

2) Disconnect electrical connectors from valve body solenoid. Mark electrical connector location for reassembly reference if more than one valve body solenoid is being removed. Remove bolt, valve body solenoid and "O" ring.

CAUTION: DO NOT allow components to fall from valve body when removing valve body solenoid.

Installation

1) To install, reverse removal procedure using NEW "O" ring and NEW gaskets. Tighten valve body solenoid bolt and oil screen bolt to specification. See TORQUE SPECIFICATIONS.

2) Ensure magnet is installed in oil pan and does not interfere with valve body oil tubes. Apply 1/8" bead of Loctite 599 sealant on oil pan mounting flange. Install oil pan. Install and tighten bolts to specification. See TORQUE SPECIFICATIONS.

3) Install NEW gasket and drain plug. Tighten drain plug to specification. See TORQUE SPECIFICATIONS. Fill transmission to proper fluid level with Mopar Dexron-IIIE/Mercon ATF.

TORQUE SPECIFICATIONS

TORQUE SPECIFICATIONS

Application	Ft. Lbs. (N.m)
Drain Plug	15 (20)

	INCH Lbs. (N.m)
Neutral Safety Switch Adjusting Bolt	108 (12.2)
Neutral Safety Switch Retaining Nut	61 (6.9)
Oil Pan Bolt	65 (7.3)
Oil Screen Bolt	84 (9.5)
Speed Sensor Bolt	65 (7.3)
Valve Body Solenoid Bolt	84 (9.5)
