

PART 2

CHASSIS

CHAPTER

INDEX

Clutch	24
Manual Transmission	24
Automatic Transmission	20
Transfer Case	24
Propeller Shaft	24
Axles	24
Brakes	20
Wheels and Tires	24
Steering Columns	24
Manual Steering Gear	24
Power Steering Gear And Pump	24
Steering Linkage	24
Suspension	24

PART 2
CHASSIS

OPERATOR
INDEX

1	Introduction
2	General Information
3	Operating Instructions
4	Preparation for Operation
5	Starting the Engine
6	Normal Operation
7	Stopping the Engine
8	Emergency Procedures
9	Maintenance
10	Troubleshooting
11	Specifications
12	Appendix

CLUTCH 2A

SECTION INDEX

	Page		Page
General Information	2A-1	Clutch Service—Six- and Eight-Cylinder Models	2A-15
Clutch Service—Four-Cylinder CJ Models	2A-9		

GENERAL INFORMATION

	Page		Page
Clutch Adjustments	2A-7	General	2A-1
Clutch Service	2A-2	Service Diagnosis	2A-2
Clutch Linkage	2A-8		

GENERAL

Six- and Eight-Cylinder Models

The clutch assembly used in six- or eight-cylinder CJ, Cherokee and Truck models consists of a single dry-disc driven plate and a spring and lever-type clutch cover (fig. 2A-1). Two clutch cover styles are used. A 10.5-inch (26.7 cm) diameter direct spring pressure cover is used in CJ models with six- or eight-cylinder engines. An 11.0-inch (27.9 cm) diameter semi-centrifugal cover is used on Cherokee and Truck models with an eight-cylinder engine. An 11.0-inch (27.9 cm) diameter direct spring pressure cover is used on six-cylinder Cherokee and Truck models.

Four-Cylinder CJ Models

The clutch assembly used in four-cylinder CJ models consists of a diaphragm-type clutch cover and a single dry-disc driven plate. The cover consists of a one-piece diaphragm spring with integral release fingers (fig. 2A-2). The driven plate consists of a steel hub with four integral cushion springs and the friction material which is riveted to the hub (fig. 2A-3). The clutch cover and driven plate diameter is 9.250 inches (23.5 cm).

Clutch Hydraulic System—Four-Cylinder CJ Models

A hydraulic-clutch operating system is used on CJ models equipped with the 2.5 liter four-cylinder engine

(fig. 2A-4). The system consists of a clutch cylinder, a slave cylinder, and an interconnecting hydraulic line. The clutch cylinder is mounted on the dash panel next to the brake master cylinder. The slave cylinder is mounted on the clutch housing. The clutch cylinder is connected directly to the clutch pedal. The slave cylinder is connected to the throwout lever.

Clutch Hydraulic System Operation

When the clutch pedal is pressed down, hydraulic fluid from the clutch cylinder flows into the slave cylinder causing the slave cylinder push rod to extend. Since the push rod is connected to the throwout lever, the lever moves the throwout bearing into contact with the clutch cover release fingers to disengage the clutch.

NOTE: On four-cylinder CJ models with the clutch hydraulic operating system, the clutch pedal must be fully depressed before complete clutch disengagement will occur.

Clutch Hydraulic Fluid

The hydraulic fluid that operates the clutch hydraulic mechanism is contained in the clutch cylinder reservoir. When adding fluid to, or refilling the system after service operations, use AMC/Jeep brake fluid, or equivalent, marked SAE J-1703 or DOT 3 only. Do not use any type of mineral or paraffin base oils in the system. These fluids will damage the rubber parts in the clutch and slave cylinders.

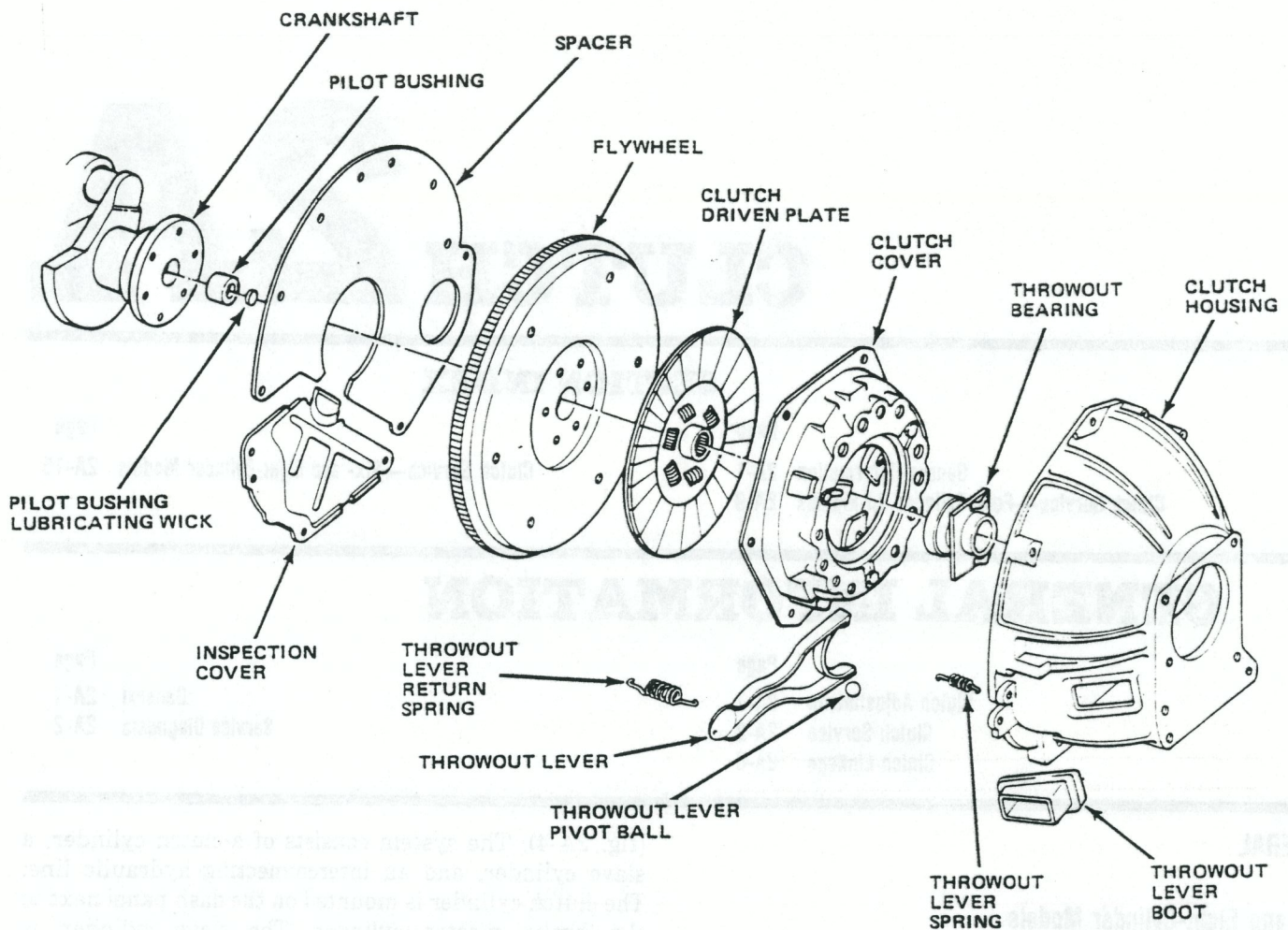

90031

Fig. 2A-1 Clutch Assembly—Six- and Eight-Cylinder Models

Clutch Hydraulic Fluid Level

The desired fluid level is indicated on the side of the clutch cylinder. When refilling the system, fill the cylinder reservoir to the level indicated on the side of the reservoir only. Do not overfill the reservoir.

Throwout Bearing

CJ models equipped with the 2.5 liter four-cylinder engine use a throwout bearing that is similar to the bearing used on six- and eight-cylinder CJ, Cherokee and Truck models. The four-cylinder throwout bearing contact face is slightly crowned. The six- and eight-cylinder throwout bearing contact face is flat. Refer to figure 2A-4 for an illustration of bearing configuration.

CLUTCH SERVICE

On four-cylinder CJ models, the components that form the clutch hydraulic system are fully serviceable.

Refer to the Clutch Service—Four-Cylinder CJ Models section for all necessary service procedures.

On all models the clutch cover, driven plate and throwout bearing are serviced as assemblies only. Do not attempt to disassemble any of these components to effect repairs. If any of these components are damaged or severely worn, replace the component as an assembly only.

SERVICE DIAGNOSIS

General

Clutch problems can generally be assigned to one of the following categories defined as:

- Clutch chatter
- Clutch slippage or inadequate clutch pedal free play
- Clutch drag or inadequate clutch release
- Clutch pedal pulsation
- Clutch-related vibration
- Clutch area noises

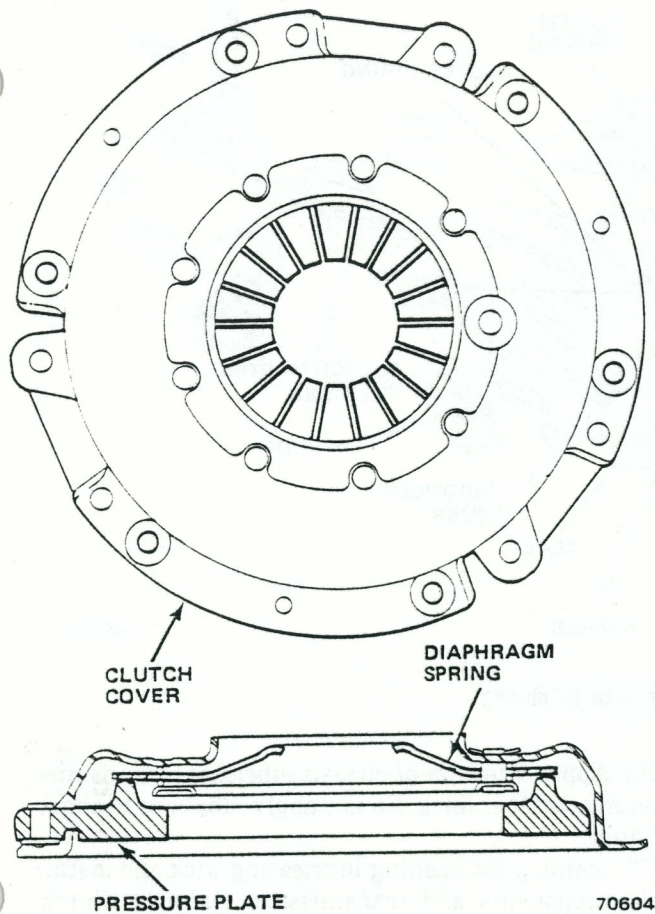

Fig. 2A-2 Clutch Cover—Four-Cylinder CJ Models

Each category is described in common complaint language and followed by simplified diagnosis and repair procedures.

NOTE: Before performing any of the following diagnosis and repair procedures, adjust pedal free play on vehicles with six- and eight-cylinder engines and be sure the clutch pedal returns to the pedal stop completely. On four-cylinder CJ models, check the hydraulic cylinders and connecting line for damage and leakage.

Clutch Chatter

Clutch chatter can be described as a shaking or shuddering sensation felt throughout the vehicle. Chatter usually develops when the clutch cover pressure plate makes initial contact with the driven plate and ceases when the clutch is fully engaged (clutch pedal released). Check clutch operation as follows:

WARNING: The following test requires clutch engagement to the point of vehicle movement. Do not allow anyone to stand at the front or rear of the vehicle during this test.

(1) Start engine, press clutch pedal to floor and shift transmission into first gear.

(2) Increase engine speed to 1200/1500 rpm and slowly release clutch pedal. When pressure plate makes initial contact with driven plate, note clutch operation. Press clutch pedal to floor and release accelerator pedal.

(3) Shift transmission into reverse and repeat procedure outlined in step (2).

(4) If clutch chatter does not develop in either gear range, increase engine speed to 1700/2200 rpm and repeat steps (2) and (3).

(5) If clutch chatter does not develop after performing tests outlined in steps (1) through (4), problem may be improper operation by owner. If clutch chatter does develop, proceed to next step.

(6) Raise vehicle on hoist.

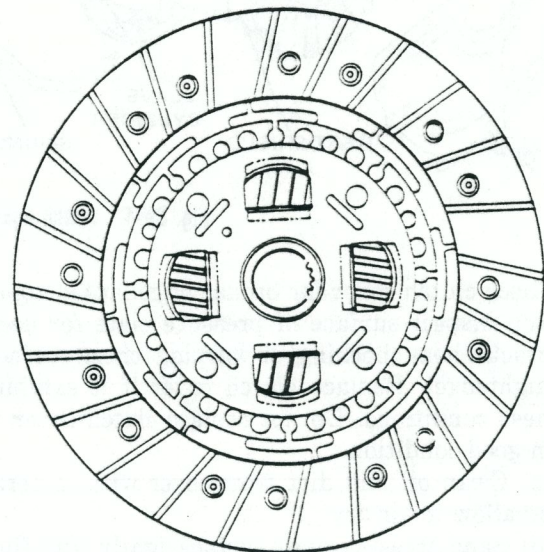

Fig. 2A-3 Clutch Driven Plate—Four-Cylinder CJ Models

(7) Check for loose or broken front or rear engine support cushions. Tighten or replace as necessary. Check for loose clutch housing-to-engine or housing adapter-to-transmission attaching bolts. Tighten as necessary. Refer to torque specifications in this section. Check for binding, worn, bent or broken clutch linkage components. Lubricate or replace as necessary.

(8) If components inspected are in good condition, proceed to next step. If one or more problems were discovered and corrected, lower vehicle and repeat step (1). If chatter is still evident, proceed to next step.

(9) Remove transmission and clutch components as outlined in this chapter.

NOTE: Whenever the clutch components are removed, also remove the pilot bushing lubricating wick, soak the wick in engine oil and reinstall the wick before assembly.

(10) Check for oil or grease contamination of driven plate. If contaminated, correct cause of contamination and replace driven plate.

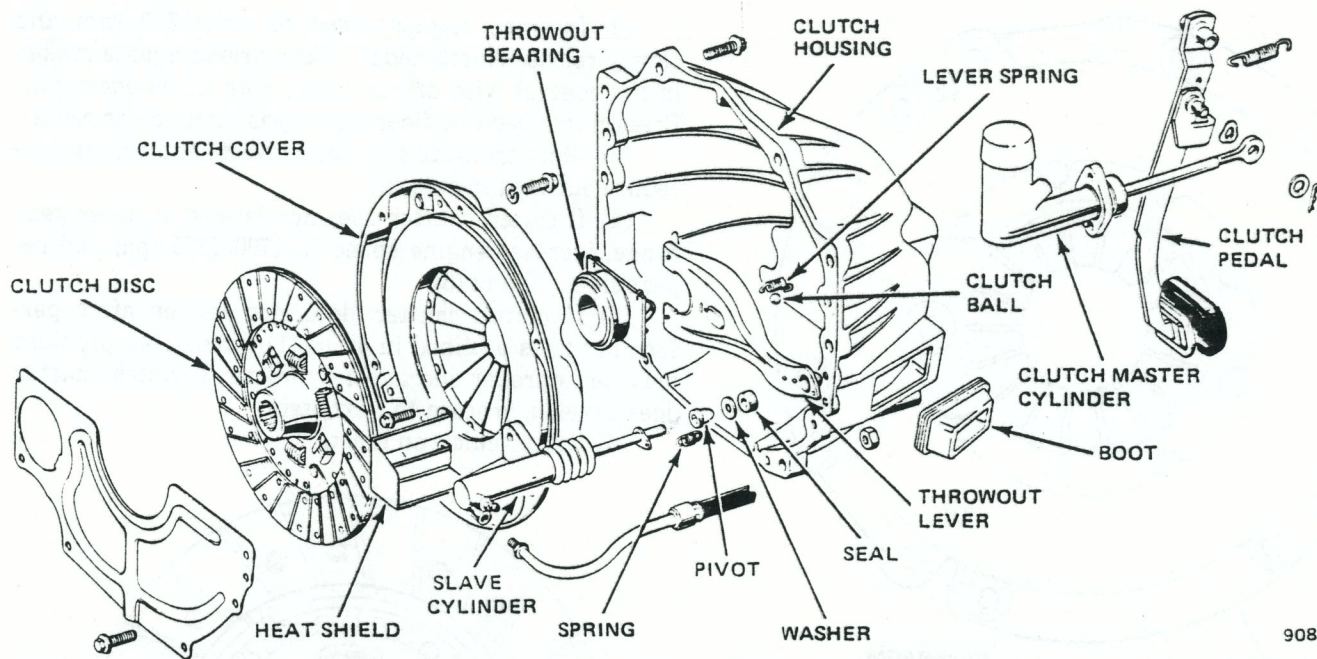

90801B

Fig. 2A-4 Clutch Assembly—Four-Cylinder CJ Models

(11) Check clutch cover for broken or collapsed apply springs and inspect surface of pressure plate for deep scoring, cracks, heat checking, or warping (check surface with straightedge). Replace clutch cover if it exhibits any of these conditions. Do not replace clutch cover if cover is in good condition.

(a) Clean oil and dirt from cover with mineral spirits and allow to air dry.

(b) Sand pressure plate surface lightly with fine emery cloth.

(c) Lubricate release lever pivots and check release lever height. Adjust height if necessary.

CAUTION: Apply lubricant to pivots sparingly. Excessive lubrication could result in grease contamination of the pressure plate and driven plate surfaces.

(12) Inspect crankshaft pilot bushing. Replace bushing if worn, deeply scored, or discolored.

NOTE: Soak replacement bushing in engine oil before installation.

(13) Inspect condition of splines on transmission clutch shaft and in driven plate hub. If splines are worn, galled, chipped or broken, replace clutch shaft or driven plate. Remove corrosion, rust, or burrs from splines using oilstone or fine-tooth file. Install driven plate on clutch shaft. Plate must move freely on shaft.

(14) If all clutch components are in good condition, proceed to next step. If one or more components were determined to be faulty, repair as necessary and proceed to next step.

(15) Check clutch housing alignment as outlined in this chapter. Correct alignment if necessary and proceed to next step.

(16) Apply thin film of chassis lubricant to transmission clutch shaft splines. Do not apply lubricant to shaft pilot hub.

(17) Install pilot bushing lubricating wick and install clutch components and transmission. Refer to Clutch Installation.

NOTE: Do not replace the throwout bearing unless it is defective or damaged. Refer to Clutch Area Noises.

Clutch Slippage Or Inadequate Clutch Linkage Free Play

Clutch slippage can be described as a condition in which the engine overspeeds but does not generate any increase in torque supplied to the wheels. Clutch slippage occurs when the driven plate is not gripped firmly between the flywheel and clutch cover pressure plate and rotates or slips between them at high torque. Clutch slippage can occur during initial acceleration or during subsequent shifts. Check clutch operation as follows:

(1) Block wheels and apply parking brake.

(2) Operate engine until it reaches normal operating temperature.

(3) Shift transmission into third gear and increase engine speed to 2000 rpm.

WARNING: Do not permit anyone to stand in front of the vehicle during this test.

(4) Slowly release clutch pedal until clutch is fully engaged.

CAUTION: Do not allow the clutch to be engaged for more than 5 seconds at a time as the clutch components could be damaged.

(5) If engine stalls within 5 seconds, clutch is not defective. If engine continues to run, proceed to next step.

(6) Raise vehicle on hoist. Check clutch linkage for binding, worn, broken, or bent components. Lubricate or replace as necessary. If all components inspected are in good operating condition, proceed to next step.

(7) If one or more problems were discovered and corrected during inspection in previous step, repeat steps (1) through (4). If clutch slippage is corrected, stop repair. If slippage persists, proceed to next step.

(8) Remove transmission and clutch components. Refer to Clutch Removal.

NOTE: *Whenever the transmission is removed, also remove the pilot bushing lubricating wick, soak the wick in engine oil, and reinstall the wick before assembly.*

(9) Inspect driven plate. If 1/16 inch (2 mm) or less friction material remains above rivet heads, or plate is severely glazed or contaminated with oil or grease, replace driven plate.

NOTE: *If the driven plate is contaminated, determine the cause and make correction before proceeding.*

(10) Inspect clutch cover. If cover is heat-checked, has broken or collapsed springs, or exhibits signs of overheating (e.g., has blue coloration), replace cover. If cover does not exhibit any of these conditions, do not replace it.

(a) Clean oil and dirt from cover using mineral spirits and allow cover to air dry.

(b) Sand pressure plate surface lightly using fine emery cloth.

(c) Lubricate cover release lever pivots and check and adjust release lever height as necessary.

CAUTION: *Apply lubricant to the pivots sparingly. Excessive lubrication could result in grease contamination of the driven plate and pressure plate surfaces.*

(11) Check throwout bearing mounting surface of transmission front bearing cap for galling, deep scores, or roughness. Install throwout bearing on bearing cap and check for smooth fore/aft movement. Replace bearing or bearing cap as necessary if bind occurs. Fill throwout bearing groove with chassis grease and apply thin coat of grease to bearing mounting surface of front bearing cap.

CAUTION: *The throwout bearing has retaining springs which position the bearing on the throwout lever. Check these springs for distortion, loss of tension, or for being bent or broken. Replace the bearing if these springs are damaged. Also, when installing the bearing, be sure the retaining projections on the throwout lever are properly engaged in the retaining holes in the bearing sleeve.*

NOTE: *Do not replace the throwout bearing unless it is actually defective or damaged. Refer to Clutch Area Noises.*

(12) Apply thin film of chassis grease to transmission clutch shaft splines. Do not apply grease to shaft pilot hub.

(13) Install pilot bushing and lubricating wick.

(14) Install clutch components and transmission. Refer to Clutch Installation.

(15) Lower vehicle.

Clutch Drag Or Inadequate Release

Clutch drag can be described as a condition in which the clutch driven plate, and consequently the transmission clutch shaft, does not come to a complete stop after the clutch pedal is depressed (clutch disengaged). Clutch drag can cause gear clash when shifting into reverse or hard or difficult shifting. Check clutch operation as follows.

NOTE: *Occasionally, the clutch driven plate and clutch shaft will require approximately 5 seconds to lose momentum and come to a complete stop after initial clutch disengagement. This is normal and should not be mistaken for clutch drag.*

(1) Start engine, depress clutch pedal fully, and shift transmission into first gear.

(2) Shift transmission into neutral but **do not** release clutch pedal.

(3) Wait 5 to 10 seconds and shift transmission into reverse. If shift is smooth with no gear clash, clutch operation is normal. If shifting into reverse produces gear clash, proceed to next step.

(4) Raise vehicle on hoist. Check clutch linkage for binding, worn, broken or bent components. Lubricate or replace as necessary. If components are in good operating condition, proceed to next step. If one or more problems were discovered and repaired, lower vehicle and repeat steps (1) through (3). If clutch now operates correctly, stop repair. If clutch drag persists, proceed to next step.

(5) Remove transmission and clutch components. Refer to Clutch Removal.

NOTE: *Whenever the transmission is removed, also remove the pilot bushing lubricating wick, soak the wick in engine oil, and reinstall the wick before assembly.*

(6) Observe wear pattern on driven plate. If wear pattern is uneven (e.g., two areas heavily worn on one side, two only partially worn on opposite side), or has opposing wear patterns on front and reverse side, the driven plate is warped and should be replaced.

(7) Inspect clutch cover assembly. If clutch cover assembly has worn, bent, or broken release levers or lever pivots, is heavily scored, or warped, replace clutch

cover assembly. If cover assembly does not exhibit any of these conditions, do not replace it.

(a) Clean oil and dirt from clutch cover with solvent and allow cover to air dry.

(b) Sand pressure plate surface lightly using fine emery cloth.

(c) Lubricate cover release lever pivots with chassis grease.

NOTE: *Apply lubricant to pivots sparingly. Excessive lubricant could result in grease contamination of pressure plate and driven plate surfaces.*

(8) Check and adjust clutch cover release lever height as necessary.

NOTE: *If the release lever height cannot be adjusted, the release lever(s) are bent. Replace the clutch cover.*

(9) Inspect crankshaft pilot bushing for heavy scoring, angular wear pattern, or discoloration. Replace as necessary. Be sure to soak bushing in engine oil before installation.

NOTE: *If the pilot bushing displays an angular-type wear pattern, check and correct clutch housing alignment before proceeding. Refer to Clutch Housing Alignment.*

(10) Inspect condition of splines on transmission clutch shaft and in driven plate hub. If severely worn, galled, or corroded, replace clutch shaft or driven plate. Corrosion, rust, or burrs can be removed from splines using an oilstone or fine-tooth file. Install driven plate on clutch shaft. Driven plate must move freely on shaft.

(11) If components inspected in previous steps are in good condition, proceed to next step. If one or more problems were discovered during inspection procedure, repair as necessary and proceed to next step.

(12) Check clutch housing alignment. Refer to Clutch Housing Alignment. Correct alignment if necessary and proceed to next step.

(13) Apply thin film of chassis grease to transmission clutch shaft splines. Do not apply grease to shaft pilot hub.

(14) Install pilot bushing lubricating wick.

(15) Install transmission and clutch components. Refer to Clutch Installation.

(16) Lower vehicle.

NOTE: *Do not replace the throwout bearing unless actually defective. Refer to Clutch Area Noises.*

Clutch Pedal Pulsation

Clutch pedal pulsation can be described as a rapid up-and-down or pumping-type movement of the pedal that is not accompanied by any noise. In most cases, pedal movement is slight and cannot be observed but can be felt by the driver. However, on occasion, pedal movement will be great enough to be visually observed and cause a noticeable vibration.

Clutch pedal pulsation occurs when the throwout bearing makes initial contact with the clutch cover release levers (clutch partially disengaged), or at any time the bearing is in contact with the release levers. Pulsation is usually caused by incorrect clutch release lever height or clutch housing misalignment. Check clutch operation as follows.

(1) Start engine, slowly depress clutch pedal until throwout bearing makes initial contact with clutch release levers, and check for pulsation.

NOTE: *Some minor pulsation is normal.*

(2) Continue to depress clutch pedal while checking for pulsation until pedal is fully depressed.

(3) If pulsation is not evident or is minor, stop repair. If pulsation is very rapid and can be felt throughout vehicle, refer to Clutch-Related Vibrations. If vehicle displays pulsation symptoms, proceed to next step.

(4) Remove transmission and clutch components. Refer to Clutch Removal.

(5) Remove pilot bushing lubricating wick and soak wick in engine oil.

(6) Inspect clutch cover release levers. If levers are bent or excessively worn, replace clutch cover and proceed to step (8). If release levers are in good condition, clean oil and dirt from clutch cover assembly using mineral spirits, allow assembly to air dry and proceed to next step.

(7) Sand clutch cover pressure plate surface lightly using fine emery cloth.

(8) Lubricate clutch cover release lever pivots lightly with chassis grease.

NOTE: *Apply lubricant to the pivots sparingly. Excessive lubrication could result in grease contamination of the driven plate and pressure plate surface.*

(9) Check and adjust clutch cover release lever height if necessary.

NOTE: *If release lever height cannot be adjusted, the levers are bent and the cover must be replaced.*

(10) Check clutch housing alignment. Refer to Clutch Housing Alignment. Correct alignment if necessary and proceed to next step.

(11) Apply thin film of chassis grease to transmission clutch shaft splines but do not apply grease to shaft pilot hub.

(12) Install pilot bushing lubricating wick.

(13) Install clutch components and transmission. Refer to Clutch Installation.

Clutch Related Vibrations

Clutch related vibrations differ from pedal pulsations in frequency and magnitude. They usually occur at relatively high engine speeds (over 1500 rpm), are not affected by clutch pedal position, and can be felt throughout the vehicle.

Although clutch related vibrations are usually caused by clutch component imbalance, this condition occurs very infrequently because the clutch cover and driven plate are balanced as a unit during assembly. At this time, the cover and plate are installed on the crankshaft/flywheel assembly and given a final fine-tune balance before installation in the vehicle.

Replacement of clutch components to correct vibrations should be performed only after exhausting all other possibilities. Check clutch operation as follows.

(1) Raise vehicle on hoist and check engine front support cushion interlocks for grounding. Repair as necessary. Check other engine components (e.g., exhaust manifold, valve cover, etc.) for grounding on body or frame. If one of these components is grounded, repair and check for vibration. If vibration ceases, stop repair. If vibration continues, lower vehicle and proceed to next step.

(2) Disconnect accessory drive belts one at a time, start engine, and check for vibration. If vibration stops after removal of a drive belt, cause of vibration is related to accessory driven by belt or by belt itself. Repair as necessary. If vibration persists after checking all belts and accessories, proceed to next step.

(3) Raise vehicle on hoist and remove transmission and clutch housing. Refer to Clutch Removal.

(4) Support engine firmly.

(5) Check for loose flywheel mounting bolts. Tighten bolts to 105 foot-pounds (142 N•m) torque if necessary and operate engine. If vibration ceases, stop repair. If vibration is still evident, proceed to next step.

(6) Check flywheel face runout while holding crankshaft end play to zero. If runout is 0.005 inch (0.12 mm) or less, proceed to next step. If runout exceeds 0.005 inch (0.12 mm), replace flywheel and operate engine. If vibration ceases, stop repair. If vibration is still evident, proceed to next step.

(7) Check for damaged crankshaft vibration dampener. If dampener is in good condition, proceed to next step. If dampener is damaged, replace dampener and operate engine. If vibration ceases, stop repair. If vibration is still evident, proceed to next step.

(8) Check clutch cover imbalance as follows:

(a) Remove clutch cover and driven plate from flywheel.

(b) Start and operate engine at speed where vibration occurred.

(c) If vibration ceases, replace clutch cover and recheck operation. If now OK, install clutch housing and transmission. Refer to Clutch Installation.

(9) Lower vehicle.

Clutch Noises

Throwout Bearing Noise

Throwout bearing noises can be described as whirring, grating, or grinding noises that occur when the clutch pedal is depressed (clutch disengaged).

These noises usually continue until the clutch pedal is fully released (clutch engaged) and the bearing is no longer in contact with the clutch cover release levers.

Throwout bearing noise is corrected by replacing the bearing as outlined in this chapter.

NOTE: *The throwout bearing should not be replaced as a matter of course when servicing the clutch cover or driven plate. Replace the bearing only if defective.*

Transmission Clutch Shaft or Countershaft Bearing Noise

Transmission clutch shaft or countershaft bearing noises can be described as whirring, grating, or grinding noises which cease when the clutch pedal is depressed (clutch disengaged) or when the transmission is shifted into gear. These noises are most noticeable when the clutch pedal is fully released and the transmission is in neutral. Correction of these noises will require transmission removal and replacement of the problem bearing(s).

Crankshaft Pilot Bushing Noise

Pilot bushing noises can be described as squealing, howling, or elephant-type trumpeting noises which are most noticeable when the engine is cold. These noises occur during the first few inches of clutch pedal travel as the pedal is being released (partial clutch engagement) with the transmission in gear. It can also occur in very cold weather when the pedal is fully depressed (clutch disengaged) and the engine is started with the transmission in neutral. To correct pilot bushing noise, replace bushing as outlined in this section.

CLUTCH ADJUSTMENTS

Four-Cylinder CJ Models

The clutch hydraulic mechanism is self-adjusting. Free play adjustments are not required nor is there any provision for such an adjustment.

Six- and Eight-Cylinder Models

There are two clutch adjustments required: clutch pedal free play and clutch cover release lever height.

Clutch pedal freeplay should be checked and adjusted at the intervals specified in the Mechanical Maintenance Schedule, Chapter B, or whenever diagnosis indicates adjustment is needed. Refer to Clutch Pedal Free Play Adjustment in this section.

Clutch cover release lever height should be checked and adjusted whenever the cover is removed or replaced during service operations, or whenever diagnosis indicates adjustment is needed. Refer to the Clutch Service—Six- and Eight-Cylinder Models section in this chapter.

Clutch Pedal Free Play Adjustment

- (1) Lift clutch pedal upward and against pedal stop (fig. 2A-1).
- (2) Raise vehicle.
- (3) On Cherokee and Truck models, adjust clutch push rod lower ball pivot assembly in-or-out on push rod (fig. 2A-5) until bellcrank inner lever is parallel to front face of clutch housing. Lever should be slightly forward from vertical.
- (4) On all models, loosen release rod adjuster jamnut.
- (5) Turn release rod adjuster in or out to obtain specified clutch pedal free play.
- (6) Tighten release rod jamnut.
- (7) Lower vehicle.

CLUTCH LINKAGE

The suspended-type clutch pedal is connected to the throwout lever through the clutch push rod, bellcrank outer and inner levers, and release rod (figs. 2A-5 and 2A-6). The throwout bearing is mounted on the transmission front bearing cap and acts directly against the clutch cover release levers to engage and disengage the

clutch. The bearing is actuated by a throwout lever mounted in the clutch housing. The lever pivots on a steel ball mounted inside the clutch housing.

The bellcrank pivots on ball studs mounted in the inner and outer support brackets (figs. 2A-5 and 2A-6). Idler bushings, installed in each end of the bellcrank provide bearing surfaces for the ball studs.

Clutch Linkage Lubrication

The clutch linkage ball studs are the only linkage components that require periodic lubrication. The studs should be lubricated at the intervals specified in the Mechanical Maintenance Schedule, Chapter B.

Lubrication Procedure

The bellcrank has a lubrication fitting to facilitate ball stud lubrication. Whenever lubrication is necessary, proceed as follows:

- (1) Raise vehicle.
- (2) Fill lube gun with lithium-base chassis grease.
- (3) Connect lube gun nozzle to bellcrank fitting and lubricate ball studs.
- (4) Remove lube gun and lower vehicle.

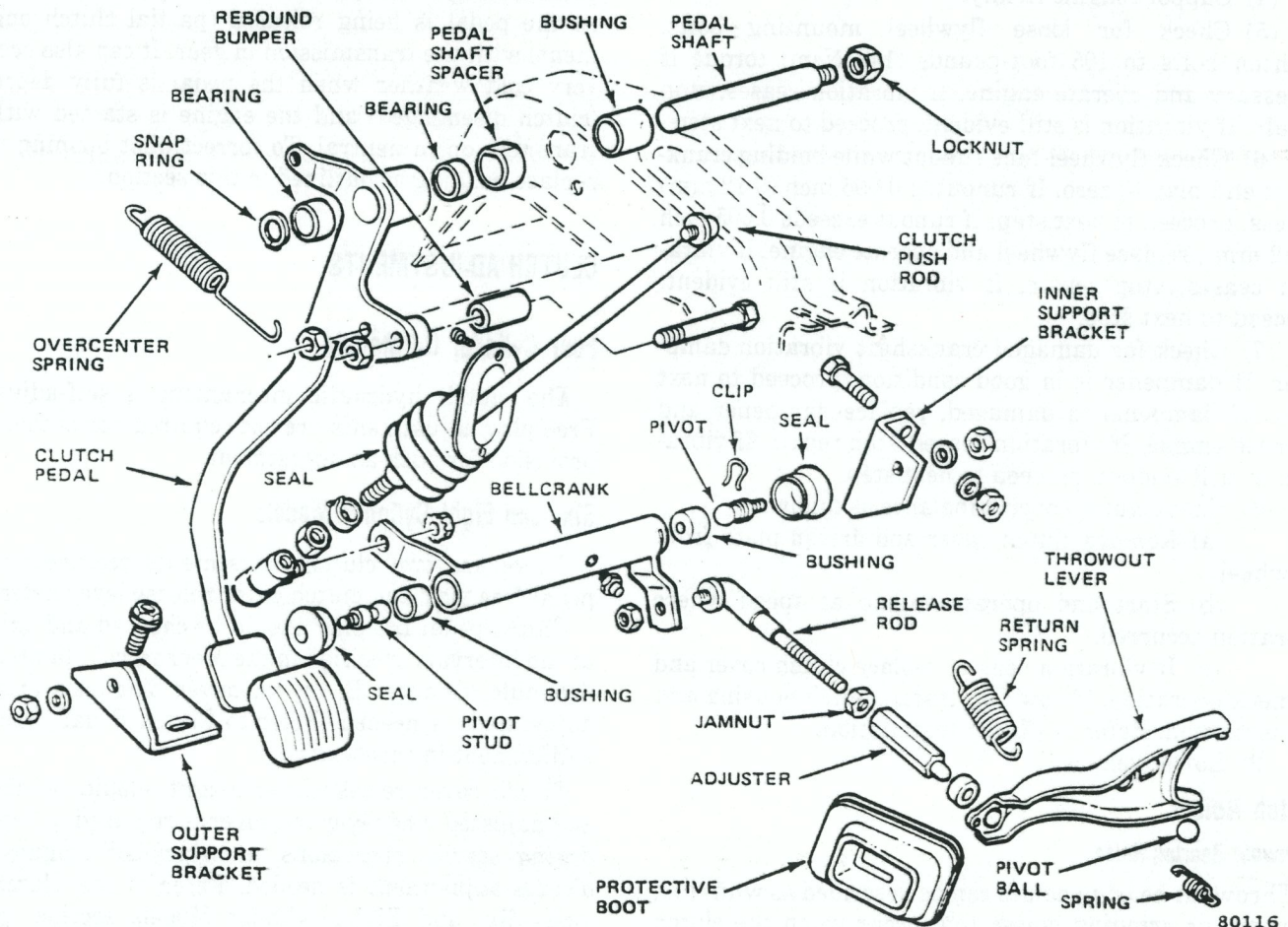
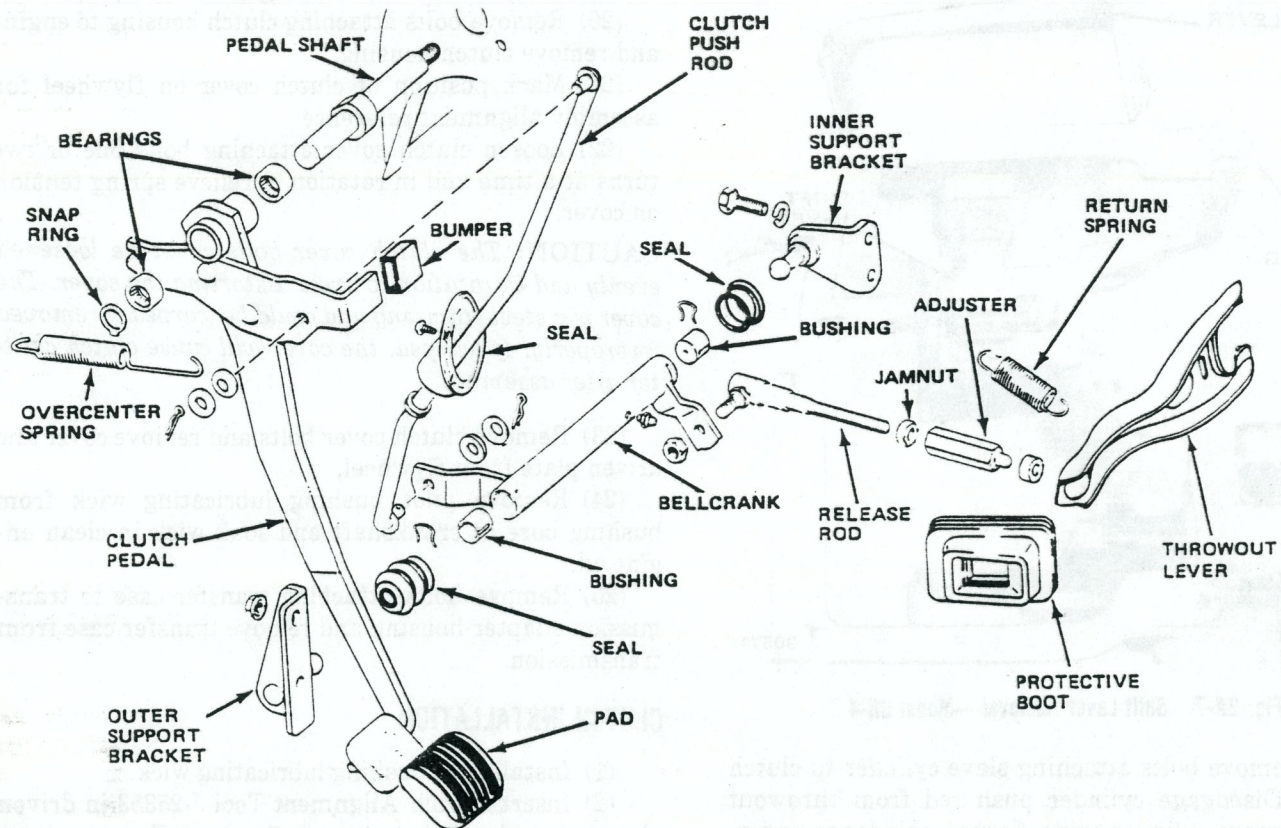

Fig. 2A-5 Clutch Linkage—Cherokee and Truck Models



60566

Fig. 2A-6 Clutch Linkage—Six- and Eight-Cylinder CJ Models

CLUTCH SERVICE — FOUR-CYLINDER CJ MODELS

	Page
Clutch Cylinder Service	2A-12
Clutch Housing Alignment	2A-12
Clutch Hydraulic System Bleeding	2A-14
Clutch Installation	2A-10
Clutch Removal	2A-9
Flywheel Replacement	2A-11

	Page
Pilot Bushing Replacement	2A-11
Slave Cylinder Service	2A-13
Specifications	2A-15
Throwout Bearing and Lever	2A-11
Tools	2A-22
Transmission Clutch Shaft	2A-12

CLUTCH REMOVAL

- (1) Remove screws attaching transmission shift lever boot to floorpan and slide boot upward on lever.
- (2) Remove bolts attaching transmission shift lever housing to transmission (fig. 2A-7). Lift shift lever and housing upward and secure assembly to floorpan with wire.
- (3) Raise vehicle.

- (4) Mark rear propeller shaft and transfer case yoke for assembly alignment reference.
- (5) Disconnect rear propeller shaft at transfer case. Move shaft aside and secure to underbody.
- (6) Position safety stand under engine to support engine.
- (7) Remove bolts/nuts attaching rear crossmember to frame rails and rear support cushion and remove crossmember.

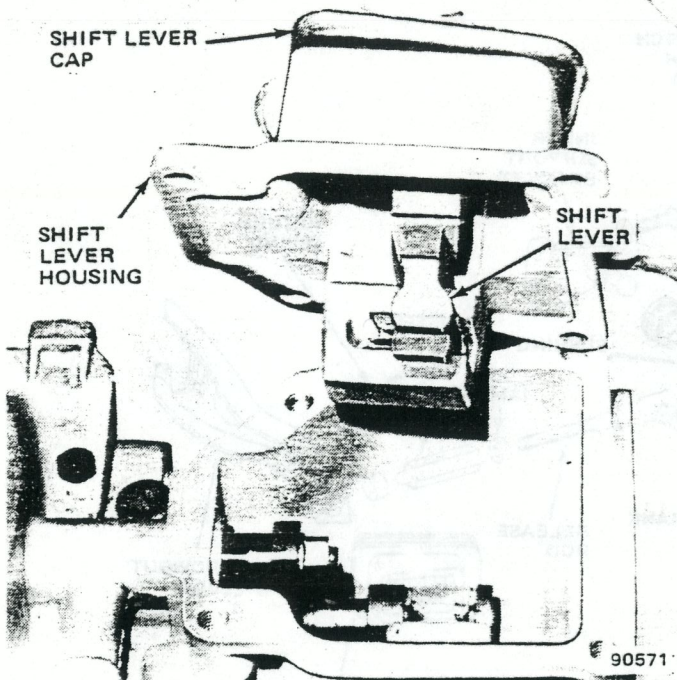

Fig. 2A-7 Shift Lever Removal—Model SR-4

(8) Remove bolts attaching slave cylinder to clutch housing. Disengage cylinder push rod from throwout lever and move cylinder aside. Secure cylinder to underbody with wire, if necessary.

(9) Drain transfer case and disconnect speedometer cable.

(10) Disconnect backup lamp switch wire.

(11) Disconnect parking brake cable, if necessary.

(12) Disconnect transfer case vent hose at transfer case and disconnect 4WD indicator switch wire.

(13) Remove starter motor.

(14) Mark front propeller shaft and transfer case yoke for assembly alignment reference.

(15) Disconnect front propeller shaft from transfer case yoke. Move shaft aside and secure to underbody with wire.

(16) Remove transfer case shift lever as follows: Remove shifter shaft retaining nut. Remove cotter pins that retain shift control link pins in shift rods and remove pins. Remove shifter shaft and disengage shift lever from shift control links. Slide lever upward in boot to move lever out of way.

NOTE: On some models, the shifter shaft is threaded into the shift lever and must be unthreaded to remove it. On other models, the shaft is removed simply by sliding it out of the lever.

(17) Support transmission-transfer case assembly with transmission jack. Use safety chain to secure assembly on jack.

(18) Remove bolts attaching transmission to clutch housing and remove transmission-transfer case assembly.

(19) Remove throwout bearing from throwout lever.

(20) Remove bolts attaching clutch housing to engine and remove clutch housing.

(21) Mark position of clutch cover on flywheel for assembly alignment reference.

(22) Loosen clutch cover attaching bolts one or two turns at a time and in rotation to relieve spring tension on cover.

CAUTION: The clutch cover bolts must be loosened evenly and in rotation to avoid distorting the cover. The cover is a steel stamping and could be warped if removed improperly. If warped, the cover will cause clutch chatter after assembly.

(23) Remove clutch cover bolts and remove cover and driven plate from flywheel.

(24) Remove pilot bushing lubricating wick from bushing bore in crankshaft and soak wick in clean engine oil.

(25) Remove bolts attaching transfer case to transmission adapter housing and remove transfer case from transmission.

CLUTCH INSTALLATION

(1) Install pilot bushing lubricating wick.

(2) Insert Clutch Alignment Tool J-25353 in driven plate hub and position plate on flywheel. Be sure alignment tool is fully seated in pilot bushing.

NOTE: Be sure the driven plate side marked flywheel side is positioned against the flywheel.

(3) Position clutch cover on flywheel and over driven plate.

(4) Align driven plate and clutch cover using alignment tool and install cover attaching bolts finger-tight only.

(5) Tighten clutch cover bolts alternately and evenly to 23 foot-pounds (31 N•m) torque.

CAUTION: To avoid warping the clutch cover, tighten the cover attaching bolts a few turns at a time only.

(6) Install clutch housing on engine and install housing attaching bolts. Tighten bolts to 54 foot-pounds (73 N•m) torque.

(7) Install throwout bearing in throwout lever. Center bearing over clutch cover release fingers.

(8) Shift transmission into gear using long handle screwdriver.

(9) Install transmission. Be sure to align transmission clutch shaft and driven plate splines before installation.

(10) Install and tighten transmission-to-clutch housing bolts to 54 foot-pounds (73 N•m) torque.

(11) Install transfer case on transmission. Raise transfer case using transmission jack. Align transmission output and transfer case input shaft splines by rotating output shaft yoke.

(12) Install and tighten transfer case attaching bolts to 30 foot-pounds (41 N•m) torque, and remove transmission jack.

(13) Position transfer case shift lever and shifter shaft. Install shaft retaining nut and tighten nut securely.

(14) Install transfer case shift control link assembly and install link retaining pins through links and shift rods. Use new cotter keys to retain link pins. Be sure shift lever is properly aligned in control link assembly.

(15) Connect vent hose to transfer case vent.

(16) Connect backup light switch and 4WD indicator switch wires.

(17) Connect speedometer cable to transfer case.

(18) Connect front and rear propeller shafts to transfer case yokes. Be sure to align shafts and yokes using assembly reference marks made previously. Tighten U-joint clamp strap bolts to 15 foot-pounds (20 N•m) torque.

(19) Install rear crossmember. Tighten crossmember attaching nuts to 30 foot-pounds (41 N•m) torque.

(20) Connect parking brake cable if cable was disconnected.

(21) Install slave cylinder on clutch housing. Be sure cylinder push rod is properly seated in throwout lever.

(22) Fill transfer case to correct level with specified lubricant. Refer to Chapter 2D.

(23) Remove stand used to support engine and lower vehicle.

(24) Install transmission shift lever assembly.

(25) Install screws attaching transmission shift lever boot to floorpan.

PILOT BUSHING REPLACEMENT

Removal

(1) Remove clutch assembly. Refer to Clutch Removal in this section.

(2) Obtain and lubricate replacement pilot bushing with engine oil.

(3) Remove pilot bushing lubricating wick and soak wick in engine oil.

(4) Remove old bushing using Tool J-5822. Or, pack bushing bore with grease, insert clutch alignment tool into bushing, and tap tool with mallet. Hydraulic pressure of grease will force bushing out.

(5) Clean crankshaft bore if grease was used to remove old bushing.

Installation

(1) Install pilot bushing lubricating wick in bushing bore in crankshaft.

(2) Install replacement pilot bushing in crankshaft bushing bore using Clutch Alignment Tool J-25353.

CAUTION: Do not allow the bushing to become cocked during installation. The bushing and installer tool must be kept parallel with the crankshaft centerline during installation.

(3) Remove bushing installer tool.

(4) Install clutch, transmission, and transfer case assemblies. Refer to Clutch Installation in this section.

THROWOUT BEARING AND LEVER

Removal

(1) Remove transmission-transfer case assembly. Refer to Clutch Removal in this section.

(2) Remove throwout lever boot.

(3) Disconnect throwout lever spring (fig. 2A-5).

(4) Remove throwout lever and bearing as assembly.

(5) Remove throwout bearing from lever.

Installation

(1) Fill slots in inner groove of replacement throwout bearing with AMC/Jeep chassis lubricant, or equivalent.

(2) Position throwout lever on pivot ball in clutch housing and connect lever spring to lever.

(3) Install throwout lever boot.

(4) Install throwout bearing in lever. Be sure bearing retaining springs are engaged in lever and that locating lugs on lever are seated in locating slots in bearing.

(5) Install transmission-transfer case assembly. Refer to Clutch Installation in this section.

FLYWHEEL REPLACEMENT

Removal

(1) Remove clutch, transmission, and transfer case assemblies. Refer to Clutch Removal in this section.

(2) Remove bolts attaching flywheel to crankshaft flange and remove flywheel.

Installation

(1) Mount flywheel on crankshaft flange and install attaching bolts finger-tight.

(2) Tighten flywheel attaching bolts alternately and evenly to 65 foot-pounds (88 N•m) torque.

(3) Clean surface of replacement flywheel with alcohol to remove all traces of oil, grease, or other protective substances.

(4) Install clutch, transmission, and transfer case assemblies. Refer to Clutch Installation in this section.

TRANSMISSION CLUTCH SHAFT

If the transmission clutch shaft requires replacement, remove and disassemble the transmission and replace the shaft. Refer to Chapter 2B—Manual Transmission for the necessary service procedures.

CLUTCH HOUSING ALIGNMENT

The clutch housing alignment procedure for four-cylinder CJ models is the same as for six- or eight-cylinder models without transmission adapters. Refer to Clutch Housing Alignment—Alignment Check without Transmission Adapter in the Six- and Eight-Cylinder Model Clutch service section.

CLUTCH CYLINDER SERVICE

Removal

(1) Disconnect hydraulic line at clutch cylinder (fig. 2A-8). Use flarenut wrench to loosen and remove fitting as fitting hex may be damaged by open end wrench.

(2) Cap hydraulic line and cylinder opening to prevent dirt entry.

(3) Remove cotter pin and washer that retain cylinder push rod on clutch pedal and slide rod off pedal pivot.

(4) Remove nuts attaching clutch cylinder to mounting studs on dash panel and remove cylinder.

Disassembly

(1) Remove reservoir cap and rubber cover. Place cap and cover on clean, lint free paper or cloth.

NOTE: *It is not necessary to remove the rubber outer cover from the reservoir cap unless the cover is damaged.*

(2) Remove push rod dust cover. Use screwdriver to pry cover off cylinder. Discard cover after removal.

(3) Remove snap ring that retains push rod in cylinder. Use needlenose pliers to compress ends of snap ring and remove ring from cylinder bore. Discard snap ring after removal.

(4) Remove push rod, retaining washer and seal as assembly (fig. 2A-9). Remove and discard push rod seal.

(5) Remove plunger, valve spring, and valve stem assembly from cylinder bore (fig. 2A-9). Tap cylinder body lightly on wood block to dislodge assembly from bore.

(6) Compress valve spring slightly and pry tab of valve stem retainer upward to release retainer, spring, and stem assembly from plunger (fig. 2A-10).

NOTE: *The retainer tab is located in the rectangular slot in the side of the stem retainer (fig. 2A-10). Use a small, thin blade screwdriver to pry the tab upward.*

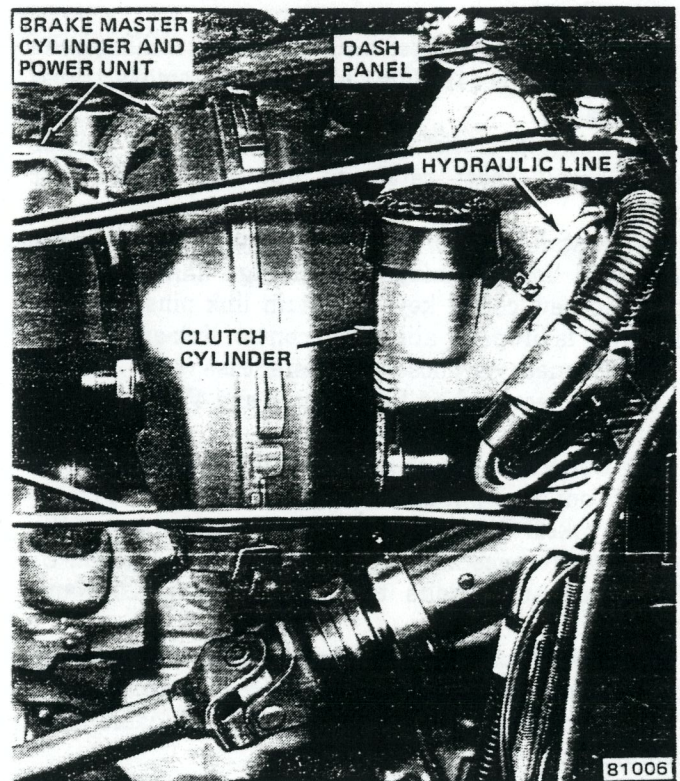

Fig. 2A-8 Clutch Cylinder Location

(7) Remove seal from plunger (fig. 2A-9). Discard seal after removal.

(8) Remove spring retainer and valve stem from valve spring.

(9) Remove valve stem from retainer and remove spring washer and stem tip seal from end of valve stem (fig. 2A-9). Discard stem tip seal and spring washer.

(10) Clean all parts thoroughly with brake fluid or brake cleaning solvent only.

(11) Inspect cylinder bore for cracks, porosity, wear, deep scoring or nicks, and severe corrosion or pitting. If bore exhibits any of these conditions, replace cylinder.

Assembly

(1) Lubricate cylinder bore with brake fluid.

(2) Install replacement seals on plunger and valve stem. Be sure lip of plunger seal faces stem end of plunger. Also be sure stem tip seal is installed so that seal shoulder fits in undercut at end of valve stem.

(3) Install new spring washer on valve stem. Install plastic spring retainer on valve stem and over spring washer. Be sure large end of retainer is facing end of stem (fig. 2A-10).

(4) Install valve spring over stem and seat spring on stem retainer.

(5) Install assembled valve spring, retainer, and stem assembly on plunger (fig. 2A-10). Compress spring against plunger. When end of valve stem passes through

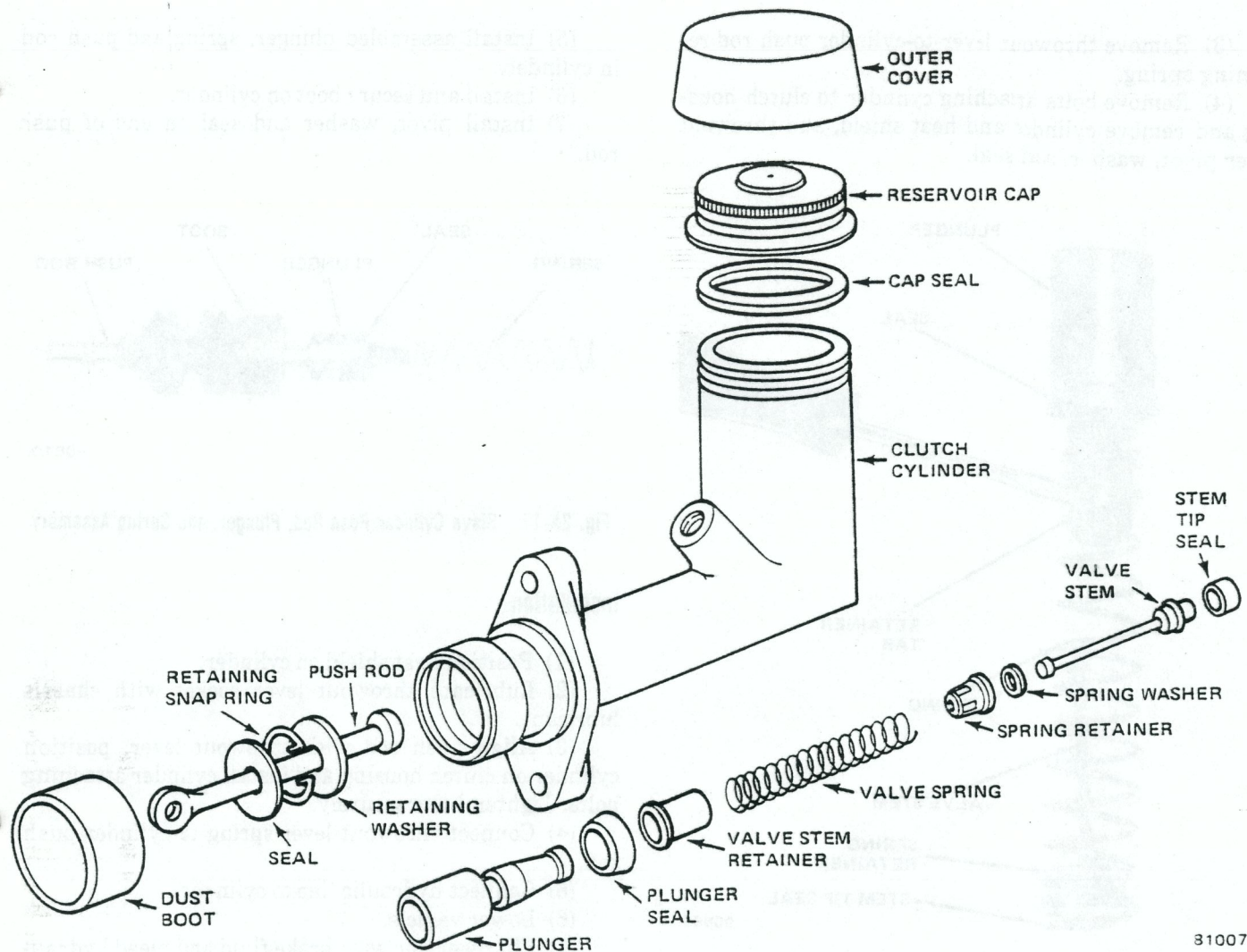

31007

Fig. 2A-9 Clutch Cylinder Assembly

stem retainer and seats in small bore in end of plunger, bend retainer tab downward to lock stem and retainer on plunger.

(6) Lubricate spring and plunger assembly with brake fluid and insert assembly (spring end first) into cylinder bore.

(7) Install new seal and dust cover on push rod.

(8) Lubricate ball-end of push rod, seal, and lip of dust cover with lubricant supplied in cylinder overhaul kit.

(9) Insert push rod and push rod retainer into cylinder bore. Secure push rod and retainer in bore using replacement snap ring supplied in overhaul kit.

(10) Slide push rod seal up against push rod retainer and install dust cover on end of cylinder. Be sure cover lip is seated in undercut on end of cylinder.

(11) Remove and discard old seal from filler cap and install new seal supplied in kit.

(12) Install rubber outer cover on filler cap, if removed.

Installation

(1) Install clutch cylinder on dash panel mounting studs. Tighten cylinder attaching nuts to 11 foot-pounds (15 N•m) torque.

(2) Connect hydraulic line to clutch cylinder.

(3) Install cylinder push rod on clutch pedal pivot and install retaining washer and cotter pin.

(4) Fill clutch cylinder reservoir with brake fluid to level indicated on side of reservoir. Use AMC/Jeep brake fluid, or equivalent, marked SAE J-1703 or DOT 3 only to fill reservoir.

(5) Install reservoir cap and bleed clutch hydraulic system. Refer to Clutch Hydraulic System Bleeding.

SLAVE CYLINDER SERVICE

Removal

(1) Raise vehicle.

(2) Disconnect hydraulic line at cylinder.

- (3) Remove throwout lever-to-cylinder push rod retaining spring.
- (4) Remove bolts attaching cylinder to clutch housing and remove cylinder and heat shield, and throwout lever pivot, washer, and seal.

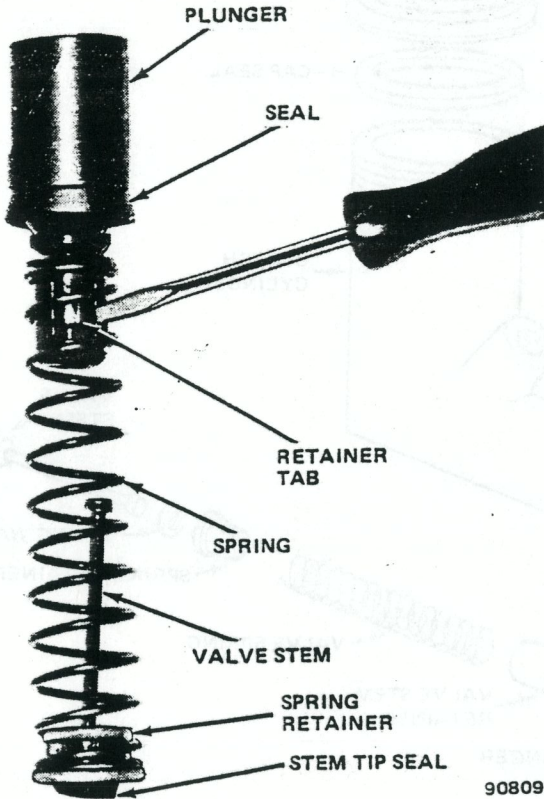

Fig. 2A-10 Removing Valve Spring and Stem from Plunger

Disassembly

- (1) Clean cylinder exterior thoroughly.
- (2) Remove boot from cylinder.
- (3) Remove cylinder push rod, boot, plunger and spring as assembly (fig. 2A-11).
- (4) Remove spring and seal from plunger.
- (5) Remove snap ring that retains push rod in plunger and remove push rod and boot.
- (6) Remove boot from push rod.
- (7) Clean parts with brake fluid.

Assembly

- (1) Install new boot on push rod.
- (2) Install push rod in plunger and install new push rod retaining snap ring.
- (3) Install spring on plunger.
- (4) Lubricate cylinder bore and seal with brake fluid.

- (5) Install assembled plunger, spring and push rod in cylinder.
- (6) Install and secure boot on cylinder.
- (7) Install pivot, washer and seal on end of push rod.

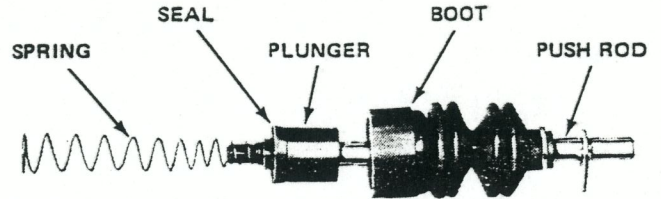

Fig. 2A-11 Slave Cylinder Push Rod, Plunger, and Spring Assembly

Installation

- (1) Position heat shield on cylinder.
- (2) Lubricate throwout lever socket with chassis lubricant.
- (3) Align push rod with throwout lever, position cylinder on clutch housing and install cylinder attaching bolts. Tighten bolts securely.
- (4) Connect throwout lever spring to cylinder push rod.
- (5) Connect hydraulic line to cylinder.
- (6) Lower vehicle.
- (7) Fill reservoir with brake fluid and bleed hydraulic system. Refer to Clutch Hydraulic System Bleeding.

CLUTCH HYDRAULIC SYSTEM BLEEDING

- (1) Fill reservoir with brake fluid.
- (2) Raise vehicle.
- (3) Compress slave cylinder plunger by pushing throwout lever forward as far as possible.
- (4) Attach one end of rubber hose to slave cylinder bleed screw. Place opposite end of hose in glass container 1/2 full of brake fluid. Be sure hose end is submerged in fluid.
- (5) Loosen bleed screw.
- (6) Have helper press and hold clutch pedal to floor. Tighten bleed screw and release pedal. Repeat bleeding operation until fluid entering container is free of bubbles.

NOTE: Do not allow the reservoir to run out of fluid during the bleeding operation.

- (7) Lower vehicle.
- (8) Adjust reservoir fluid level to level indicated on reservoir after completing bleeding operations.

SPECIFICATIONS

Torque Specifications

Service Set-To Torques should be used when assembling components. Service In-Use Recheck Torques should be used for checking a pre-torqued item.

	USA (ft -lbs)		Metric (N•m)	
	Service Set-To Torque	In-Use Recheck Torque	Service Set-To Torque	In-Use Recheck Torque
Clutch Cover Bolts:				
Four-Cylinder	23	20-26	31	27-35
Clutch Housing-to-Engine Bolts:				
Four-Cylinder — All	54	46-62	73	62-84
Clutch Housing-to-Transmission Bolts:				
Four-Cylinder	54	46-62	73	62-84
Starter Motor-to-Clutch Housing Bolts:				
Four-Cylinder	54	46-62	73	62-84
Clutch Cable Locknut:				
Four-Cylinder	25	21-29	34	28-39
Clutch Housing Inspection Cover Screws:				
Four-Cylinder	30	25-35	41	34-47
Flywheel-to-Crankshaft Bolts:				
Four-Cylinder	65	59-71	88	80-96
Rear Crossmember Stud Nuts:				
Four-Cylinder	35	30-40	47	41-54
Transmission Support Cushion-to-Crossmember Bolts:				
Four-Cylinder	25	20-30	34	27-41

All Torque values given in foot-pounds and newton-meters with dry fits unless otherwise specified.

80072B

**CLUTCH SERVICE —
SIX- AND EIGHT-
CYLINDER MODELS**

	Page		Page
Clutch Cover Release Lever Adjustment	2A-19	Clutch Pedal and Overcenter Spring Replacement—	
Clutch Housing Alignment	2A-17	Cherokee-Wagoneer-Truck	2A-21
Clutch Inspection and Service	2A-16	Clutch Removal	2A-15
Clutch Installation	2A-16	Specifications	2A-21
Clutch Pedal Replacement—CJ	2A-20	Tools	2A-22
Clutch Pedal Overcenter Spring Replacement—CJ	2A-19		

CLUTCH REMOVAL

- (1) Remove transmission as outlined in Chapter 2B.
- (2) Remove starter motor.
- (3) Remove throwout bearing.
- (4) Remove clutch housing.
- (5) Mark position of clutch cover on flywheel for assembly alignment reference.

(6) Loosen clutch cover attaching bolts one or two turns at a time and in rotation to relieve spring tension on cover.

CAUTION: *The clutch cover bolts must be loosened evenly and in rotation to avoid cover distortion. The cover is a steel stamping and could be warped if improperly removed resulting in clutch chatter when installed.*

(7) Remove clutch cover bolts and remove cover and driven plate from flywheel.

NOTE: *Observe which side of the driven plate faces the flywheel before removing the plate. Paint or chalk alignment marks on the plate for assembly reference.*

(8) Remove pilot bushing lubricating wick and soak wick in engine oil.

(9) Inspect and service clutch components as outlined under Clutch Component Inspection.

CLUTCH INSTALLATION

(1) Check and correct clutch cover release lever height if necessary. Lubricate release lever pivots sparingly. Do not over lubricate pivots.

(2) Install pilot bushing lubricating wick in crankshaft bore.

(3) Insert Clutch Alignment Tool J-22056 (Cherokee, Wagoneer and Truck), or Alignment Tool J-25353 (CJ), or spare clutch shaft in driven plate hub and mount assembled plate and tool on flywheel. Be sure alignment tool is fully seated in pilot bushing.

CAUTION: *Be sure the correct side of the driven plate faces the flywheel. Refer to the reference marks placed on the driven plate during clutch removal.*

(4) Position clutch cover on flywheel and over driven plate and alignment tool. Align cover and flywheel according to reference marks made during clutch removal and install cover attaching bolts finger tight only.

(5) Tighten cover attaching bolts alternately and evenly to 40 foot-pounds (54 N•m) torque. Be sure to maintain cover-to-plate alignment while tightening bolts.

CAUTION: *The cover attaching bolts must be tightened alternately and evenly to avoid distorting the cover.*

(6) Install clutch housing and tighten housing attaching bolts to specified torque. Refer to Specifications.

(7) Install starter motor.

(8) Install throwout bearing. On Cherokee, Wagoneer and Truck models, be sure wave washer is installed on throwout lever. On CJ models, be sure bearing tension springs are engaged in throwout lever.

(9) Install transmission as outlined in Chapter 2B.

CLUTCH INSPECTION AND SERVICE

Driven Plate

Inspect the friction material for excessive wear, or charred, cracked, broken or loose friction material.

Check the driven plate steel hub and cushion springs for distortion, cracks, or breakage. Replace the driven plate if it exhibits any of these conditions.

NOTE: *Do not replace the driven plate if the cushion springs only appear loose. This is a normal condition when the plate is removed from the vehicle and the springs are not under load.*

Clutch Cover

Inspect the cover for cracks, distortion, broken or collapsed apply springs and for broken, bent, loose, or excessively worn release levers. Inspect the pressure plate surface for deep scores, cracks, heat checking or discoloration, and for evidence of warping (use a straightedge to check pressure plate surface flatness). Replace the cover as an assembly if it exhibits any of these conditions.

NOTE: *The centrifugal rollers in the clutch cover may rattle when the cover is removed and not under load. Do not replace the cover if this occurs, it is a normal condition.*

Throwout Bearing

A simple throwout bearing design is used on Jeep vehicles. The bearing is retained on the throwout lever by tension springs.

CAUTION: *The throwout bearings used on Jeep vehicles are permanently lubricated during manufacture. Do not wash or immerse the bearings in solvent as the bearing lubricant could be dissolved. Clean the bearing by wiping it with shop towels.*

Inspect the bearing for excessive wear and deep scoring on the release lever contact surface, looseness on the sleeve, or discoloration which indicates overheating. Check the sleeve bore for excessive wear or burrs which could cause it to bind on the front bearing cap. Rotate the bearing on the sleeve. The bearing must rotate freely and not bind. When rotating the bearing, also listen for grinding or grating sounds which indicate that the internal rollers are worn or damaged. Check the bearing tension springs for distortion or breakage. Replace the bearing if it exhibits any of these conditions.

Transmission Front Bearing Cap

Inspect the bearing cap for deep scoring or excessive wear. Replace the bearing cap if worn or scored and inspect the throwout bearing sleeve for burrs, wear or other damage which could cause a bind condition. Replace the bearing cap or throwout bearing if either exhibits these conditions.

Crankshaft Pilot Bushing

Inspect the bushing for excessive wear, deep scoring, cracks, or looseness. Replace the bushing if worn or damaged.

Bushing Replacement

(1) Obtain replacement bushing and soak bushing in engine oil.

(2) Remove bushing lubricating wick.

(3) Fill crankshaft bore and pilot bushing with chassis grease.

(4) Insert clutch aligning tool into bushing and tap end of tool with lead hammer. Hydraulic pressure generated by compressed grease will force bushing out of crankshaft bore.

NOTE: If the bushing proves difficult to remove using the hydraulic method, remove the bushing using Puller Tool J-5822 and Slide Hammer J-2619-01.

(5) Remove all grease from crankshaft bore and clean bore thoroughly.

(6) Install replacement pilot bushing on clutch alignment tool.

(7) Install bushing in crankshaft bore using clutch alignment tool as bushing driver. Keep bushing straight during installation and be sure it is fully seated.

(8) Install bushing lubricating wick.

Flywheel

Inspect the flywheel surfaces for cracks, deep scoring, excessive wear, heat checking, discoloration, and excessive face runout or distortion. Check face runout using a dial indicator. Runout must not exceed 0.005 inch (0.12 mm) with the crankshaft end play held to zero. Use a straightedge to check surface flatness. Inspect the ring gear teeth for cracks, breakage, or excessive wear. If the ring gear teeth are severely milled (worn), also check the starter motor drive teeth for similar wear or damage. Check the flywheel attaching bolt torque and tighten the bolts to 105 foot-pounds (142 N•m) torque if necessary. Replace the flywheel if it exhibits any of the conditions just described.

Transmission Clutch Shaft

Install the driven plate on the clutch shaft. The driven plate must move freely on the shaft splines. If the splines have burrs, remove them using a file or oilstone. If the driven plate does not move freely on the splines, incomplete clutch release will occur resulting in hard shifting. Replace the clutch shaft if worn or damaged. Refer to Chapter 2B for procedure.

CLUTCH HOUSING ALIGNMENT

Clutch housing misalignment is caused by excessive face or bore runout of the clutch housing or housing-to-transmission adapter. Misalignment will cause improper clutch release, driven plate failure, front transmission bearing failure, premature crankshaft pilot bushing wear, and clutch noise and vibration. In severe cases, misalignment will also cause gear jump-out on deceleration. If these malfunctions occur, the rear face and bore of the clutch housing or housing-to-transmission adapter must be checked for excessive runout.

Alignment Check—Without Transmission Adapter

NOTE: Use the following procedure when the vehicle is not equipped with a clutch housing-to-transmission adapter.

(1) Remove transmission as outlined in Chapter 2B.

(2) Remove clutch housing, clutch cover, and driven plate.

(3) Remove one flywheel attaching bolt.

(4) Obtain 1/2-20 x 9-inch bolt and 1/2-20 nut for use as dial indicator support.

(5) Thread nut onto bolt until 10 or 12 bolt threads are exposed.

(6) Thread bolt into crankshaft attaching bolt hole and tighten nut to secure bolt.

(7) Install clutch housing on engine and tighten housing attaching bolts to specified torque. Refer to Specifications.

(8) Mount dial indicator on 9-inch bolt. Indicator stylus must contact rear face of clutch housing approximately 1/8-inch from edge of bore (fig. 2A-12).

(9) Rotate crankshaft and check face runout of housing. Face runout must not exceed 0.010 inch (0.25 mm) total indicator reading at any point throughout 360 degrees rotation.

NOTE: Crankshaft end play must be held to zero to obtain an accurate face runout reading. Move and hold the crankshaft forward or rearward using a pry bar to remove end play.

(10) If face runout is over specified limits, correct runout as follows:

(a) Move dial indicator aside and loosen clutch housing attaching bolts.

(b) Insert shims between housing and engine-to-housing spacer as required to correct runout (fig. 2A-13). Install shims at points A to align top of housing with bottom of housing. Install shims at points B, D, C, or E to correct runout at either side of clutch housing. Shims installed at points D and E will also align housing from bottom to top.

(c) Tighten housing attaching bolts to specified torque.

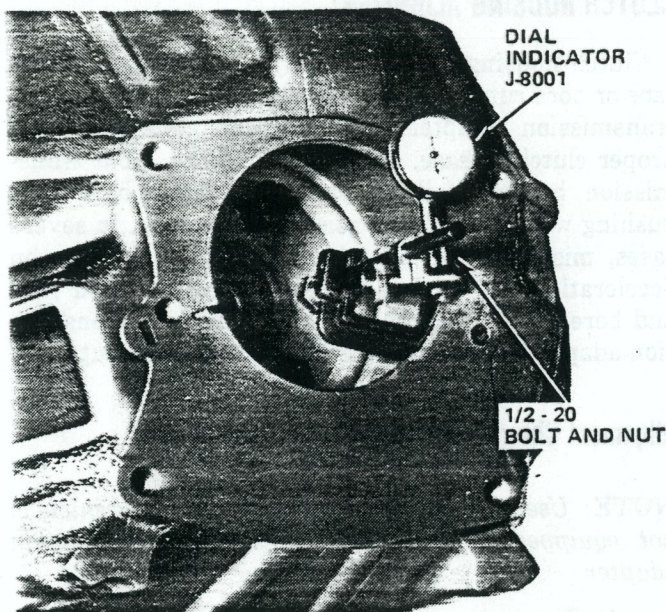
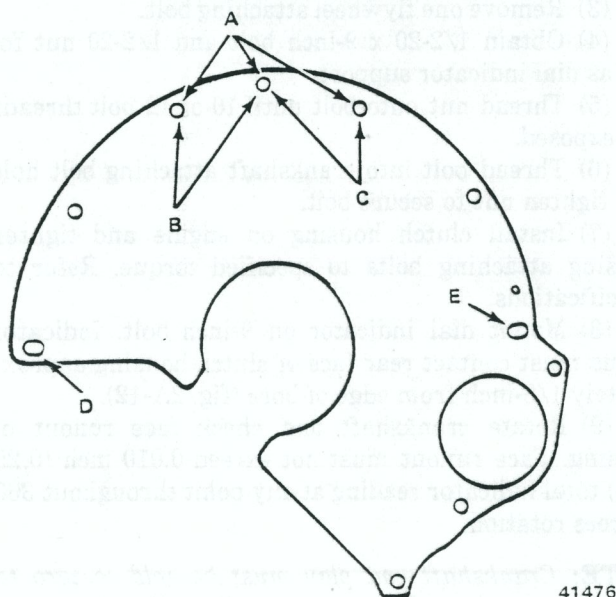

Fig. 2A-12 Mounting Dial Indicator



41476

Fig. 2A-13 Shim Placement (Six-Cylinder Engine Shown)

(d) Reposition dial indicator stylus on housing face and recheck face runout.

(e) Total face runout of clutch housing must not exceed 0.010 inch (0.25 mm). Relocate shims as necessary to correct runout.

(11) Check clutch housing bore alignment by positioning dial indicator stylus on inside diameter of housing bore.

(12) Hold crankshaft end play to zero, rotate crankshaft and note dial indicator reading at four equally spaced points. Bore runout must not exceed 0.010 inch (0.25 mm) total indicator reading at any point.

NOTE: Any change in face alignment will also change bore alignment. In some cases, it is possible to correct bore alignment simply by correcting face alignment. Where it is impossible to correct bore alignment to a maximum of 0.010 inch (0.25 mm) runout (after changing face alignment), replace the clutch housing.

Alignment Check—With Transmission Adapter

Use the following procedure to check clutch housing-to-transmission adapter alignment.

- (1) Remove transmission as outlined in Chapter 2B.
- (2) Remove clutch housing and adapter as assembly. Do not remove adapter from housing.
- (3) Remove clutch cover and driven plate.
- (4) Remove one flywheel attaching bolt.
- (5) Obtain 1/2-20 x 15-inch bolt and 1/2-20 nut for use as dial indicator support.
- (6) Thread nut onto bolt until 10 to 12 threads are exposed.
- (7) Thread bolt into flywheel attaching bolt hole and tighten nut to secure bolt.
- (8) Install clutch housing and adapter assembly and tighten housing bolts to specified torque.
- (9) Mount dial indicator on bolt. Position indicator so stylus contacts transmission mating face of adapter about 1/8 inch from edge of adapter bore.
- (10) Zero dial indicator, rotate crankshaft 360 degrees, and observe adapter face runout. Runout must not exceed 0.010 inch (0.25 mm) total indicator reading at any point through 360 degrees of rotation.

CAUTION: Crankshaft end play must be held to zero to obtain an accurate face runout reading. Move and hold the crankshaft forward or rearward using a pry bar to eliminate end play.

(11) Check bore runout of adapter. Position dial indicator so stylus contacts adapter bore at approximate center of bore.

(12) Zero dial indicator, rotate crankshaft 360 degrees, and observe runout of adapter bore. Runout must not exceed 0.010 inch (0.25 mm) at any point through 360 degrees of rotation.

NOTE: Crankshaft end play must be held to zero to obtain an accurate runout reading. Move and hold the crankshaft forward or rearward using a pry bar to eliminate end play.

(13) If adapter runout is above specified limits, correct adapter misalignment as outlined in following steps.

(14) If adapter bore runout is within limits but out of tolerance at face, shim clutch housing as required to obtain runout of 0.010 inch (0.25 mm) or less. Shim housing as outlined under Alignment Check—Without Transmission Adapter.

(15) If adapter face runout is within limits but out of tolerance at bore, proceed as follows:

(a) Loosen adapter-to-clutch housing bolts one or two turns.

(b) Move adapter up, down, or side-to-side as required to obtain runout of 0.010 inch (0.25 mm) or less. Tap adapter with hammer to reposition it.

(c) When runout is corrected, tighten adapter bolts to 35 foot-pounds (47 N•m) torque.

(d) Recheck runout and adjust adapter position again if necessary.

(16) If adapter face or bore runout cannot be brought within tolerance, replace adapter and clutch housing.

(17) If adapter and housing are replaced, install dial indicator and check runout of replacement parts.

(18) After checking and correcting adapter alignment, remove dial indicator and remove clutch housing with adapter attached. Do not remove adapter or disturb adapter position if runout was corrected.

CAUTION: *If the clutch housing was shimmed, mark the location of the shims for assembly reference before removing the housing.*

(19) Remove 1/2-20 bolt and nut from flywheel and install flywheel bolt removed previously. Tighten bolt to 105 foot-pounds (142 N•m) torque.

(20) Install driven plate and clutch cover. Tighten clutch cover bolts to 40 foot-pounds (54 N•m) torque.

(21) Install clutch housing and adapter assembly and clutch housing alignment shims as necessary.

(22) Tighten clutch housing bolts to specified torque. Refer to Specifications.

(23) Install transmission as outlined in Chapter 2B.

CLUTCH COVER RELEASE LEVER ADJUSTMENT

NOTE: *Always check and correct the release lever height adjustment, if necessary, before installing an original or replacement clutch cover.*

(1) Install Gauge Plate Tool J-1048, on flywheel in position normally occupied by driven plate (fig. 2A-14).

(2) Position clutch cover over gauge plate. Cover release levers must be directly over machined lands of gauge plate and gauge plate hub must be centered between ends of release levers.

(3) Install clutch cover on flywheel. Tighten cover attaching bolts in rotation, one or two turns at a time to avoid distorting cover.

(4) Compress each release lever several times to seat levers in operating position (fig. 2A-15). Use hammer handle to compress levers.

(5) Measure height of each lever relative to gauge hub using Clutch Lever Height Gauge Tool J-23330 (fig. 2A-16). Gauge tool has four different dimensional settings which can be used for measuring above and below hub.

(6) Adjust release levers by turning lever height adjusting nuts until lever is at desired height.

(7) After each lever has been adjusted, work lever down and up several times and recheck adjustment. If adjustment is correct, stake nut with punch to secure it.

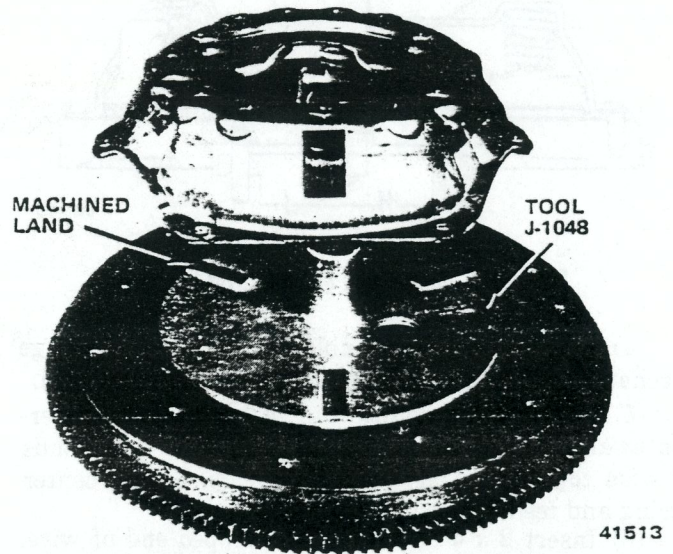

Fig. 2A-14 Mounting Gauge Plate J-1048



Fig. 2A-15 Compressing and Seating Release Levers

CLUTCH PEDAL OVERCENTER SPRING REPLACEMENT—CJ MODELS

(1) Disconnect battery negative cable.

(2) Remove main wiring harness from clip that secures harness to dash panel. Clip is located below dash panel rod mounting bracket.

(3) Center punch and drill 3/8-inch diameter access hole in dash panel, 1-3/4 inches below center of dash panel rod mounting bracket.

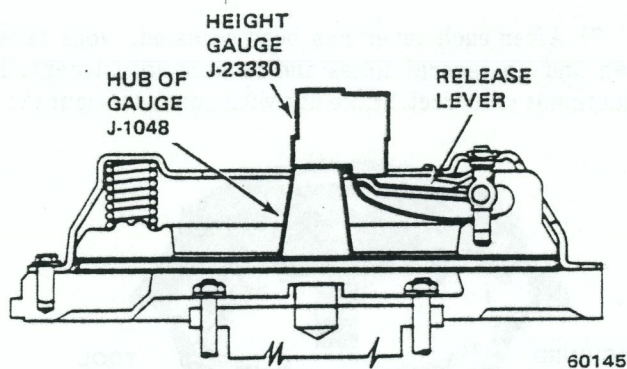

Fig. 2A-16 Measuring Release Lever Height

(4) Feed 3-foot long double strand of heavy gauge mechanics wire through hole just drilled in dash panel.

(5) Wrap wire around end of clutch pedal overcenter and feed wire back out of drilled hole. Twist ends of wire together securely to form loop. Spring center spring and feed wire back out of drilled hole.

(6) Insert 2 x 4 board through looped end of wire. Position a second 2 x 4 board against dash panel to pry against (fig. 2A-17).

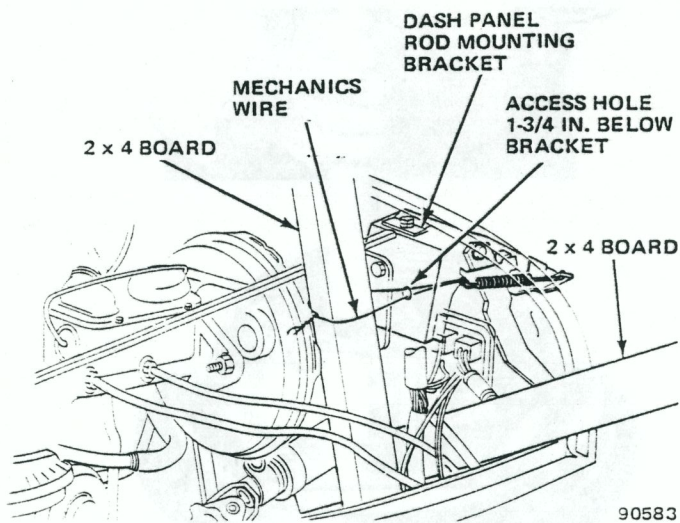

Fig. 2A-17 Clutch Pedal Overcenter Spring Removal/Installation

(7) Position bottom end of 2 x 4 board inserted in looped end of wire against 2 x 4 board on dash panel and pull back on board to release overcenter spring from clutch pedal.

CAUTION: Be sure the 2 x 4 boards do not contact any of the brake lines during overcenter spring removal or installation.

(8) Clamp vise grips on lower end of clutch pedal support bracket. Bend bracket downward to provide access to end of overcenter spring that is attached to bracket. Disconnect and remove overcenter spring after bending support bracket.

(9) Connect replacement overcenter spring to pedal support bracket.

(10) Install mechanics wire on new overcenter spring and position spring on lower portion of clutch pedal.

(11) Pull 2 x 4 board (with wire wrapped around it) forward until overcenter spring slides into and seats in pedal arm slot. Have helper observe and assist in spring seating if necessary.

NOTE: As the spring is pulled forward, it will ride along the pedal edge until it seats in the pedal slot.

(12) Remove 2 x 4 boards and mechanics wire.

(13) Plug hole drilled in dash panel.

(14) Install main wiring harness in dash panel clip.

(15) Connect battery negative cable.

CLUTCH PEDAL REPLACEMENT—CJ MODELS

(1) Disconnect battery negative cable.

(2) Disconnect clutch pedal push rod at bellcrank.

(3) Remove fuse panel attaching screws and remove panel.

(4) Remove main wiring harness from clip that secures harness to dash panel. Clip is located below dash panel rod mounting bracket.

(5) Center punch and drill 3/8-inch diameter access hole in dash panel, 1-3/4 inches below center of dash panel rod mounting bracket (fig. 2A-17).

(6) Feed 3-foot long double strand of heavy gauge mechanics wire through hole just drilled in dash panel.

(7) Wrap wire around end of clutch pedal overcenter spring and feed wire back-out of drilled hole. Twist ends of wire together securely to form loop.

(8) Insert a 2 x 4 board through looped end of wire. Position a second 2 x 4 board against dash panel to pry against (fig. 2A-17).

(9) Position bottom end of 2 x 4 board inserted in looped end of wire against 2 x 4 board on dash panel. Pull back on board to release overcenter spring from clutch pedal.

CAUTION: Be sure the 2 x 4 boards do not contact any of the brake lines during overcenter spring removal or installation.

(10) Clamp vise grips on lower end of clutch pedal support bracket. Bend bracket downward to provide access to end of overcenter spring that is attached to bracket. Disconnect and remove overcenter spring.

(11) Remove snap ring on end of pedal shaft and remove clutch pedal.

(12) Disconnect clutch pedal push rod from clutch pedal and remove clutch pedal.

(13) Lubricate bushings in replacement clutch pedal with Lubriplate, or equivalent, lubricant.

(14) Connect clutch pedal push rod to replacement clutch pedal.

(15) Install clutch pedal on pedal shaft and install snap ring on end of shaft.

- (16) Install fuse panel.
- (17) Connect clutch pedal push rod to bellcrank.
- (18) Position overcenter spring on lower portion of clutch pedal.
- (19) Pull 2 x 4 board (and mechanics wire) forward until overcenter spring slides into and seats in pedal arm slot.

NOTE: *As the spring is pulled forward, it will ride along the pedal arm edge and snap into the pedal slot.*

- (20) Remove 2 x 4 boards and mechanics wire.
- (21) Plug access hole drilled in dash panel.
- (22) Secure main wire harness in clip.
- (23) Connect battery negative cable.
- (24) Check and adjust clutch pedal free play if necessary.

CLUTCH PEDAL AND OVERCENTER SPRING REPLACEMENT—CHEROKEE-WAGONEER-TRUCK

Overcenter Spring

Overcenter Spring Removal

- (1) On vehicles with air conditioning, remove left side duct extension.
- (2) Disconnect clutch push rod at clutch pedal.
- (3) Remove clutch pedal stop.
- (4) Press clutch pedal halfway down to spread overcenter spring coils slightly and insert thin shims between overcenter spring coils.
- (5) Raise clutch pedal until pedal stops against lower edge of instrument panel.
- (6) Disconnect and remove overcenter spring from pedal and support bracket.

Installation

- (1) Insert thin shims between overcenter spring coils.
- (2) Install overcenter spring on support bracket and clutch pedal.
- (3) Remove shims from overcenter spring coils.
- (4) Connect clutch push rod to clutch pedal.
- (5) Install clutch pedal stop.

- (6) Check clutch release rod position. Be sure rod has not become disengaged from throwout lever.
- (7) Check and adjust clutch pedal free play if necessary.

Clutch Pedal

Removal

- (1) Disconnect battery negative cable.
- (2) Remove bolt attaching engine compartment wiring harness to dash panel connector.
- (3) Disconnect engine compartment wiring harness out of dash panel connector.
- (4) On vehicles with air conditioning, remove left side duct extension.
- (5) Disconnect clutch push rod at clutch pedal.
- (6) Remove clutch pedal stop.
- (7) Remove overcenter spring. Refer to Clutch Pedal Overcenter Spring Replacement—Cherokee-Wagoneer-Truck.
- (8) Remove fuse panel attaching screws and remove fuse panel.
- (9) Remove snap ring from clutch pedal end of pedal shaft using snap ring pliers with 90 degree tips.
- (10) Remove clutch pedal from pedal shaft.

Installation

- (1) Install clutch pedal on pedal shaft.
- (2) Install retaining snap ring on clutch pedal end of pedal shaft. Be sure ring is fully seated.
- (3) Install fuse panel.
- (4) Install overcenter spring. Refer to Clutch Pedal Overcenter Spring Replacement—Cherokee-Wagoneer-Truck.
- (5) Install clutch pedal stop.
- (6) Connect clutch push rod to clutch pedal.
- (7) On vehicles with air conditioning, install left side duct extension.
- (8) Connect engine compartment wiring harness to dash panel connector and install connector attaching screw.
- (9) Install battery negative cable.
- (10) Check and adjust clutch pedal free play if necessary.

SPECIFICATIONS

Clutch Specifications

Model	Engine (CID)	Clutch Diameter	Release Lever Height (Above Gauge Hub)	Pedal Free Play
CJ-5/CJ-7	151	9-1/8 (23.5 cm)	1.595 to 1.720 (40.5 to 43.7 mm)	N/A
	258 304	10-1/2 in. (26.7 cm)	3/32 to 7/64 in. (2.3 to 2.7 mm)	1 to 1-1/4 in. (25.4 to 31.7 mm)
Cherokee, Wagoneer, Truck	258	11 (27.9 cm)	3/16 (4.7 mm)	3/8 to 5/8 (9.5 to 15.8 mm)
	360			

Clutch Housing Alignment Specifications

Clutch Housing Bore to Crankshaft Centerline	0.010 max. (0.25 mm)
Clutch Housing Transmission Mounting Face to Crankshaft Centerline	0.010 max. (0.25 mm)
Clutch Housing to Transmission Adapter Bore to Crankshaft Centerline	0.010 max. (0.25 mm)
Clutch Housing to Transmission Adapter Face to Crankshaft Centerline	0.010 max. (0.25 mm)
Flywheel Runout at Face	0.005 max. (0.12 mm)

Torque Specifications

Service Set-To Torques should be used when assembling components. Service In-Use Recheck Torques should be used for checking a pre-torqued item.

	USA (ft-lbs)		Metric (N·m)	
	Service Set-To Torque	In-Use Recheck Torque	Service Set-To Torque	In-Use Recheck Torque
Clutch Bellcrank Bracket to Frame Rail Bolt (Cke., Trk.)	14	12-16	19	16-22
Clutch Bellcrank Pivot	35	30-40	47	41-54
Clutch Housing Inspection Cover Screws:				
Four-Cylinder	30	25-35	41	34-47
Clutch Housing Spacer to Block Bolt (Eight-Cylinder Engines)	15	12-17	20	16-23
Clutch Housing to Engine Block Bolt				
Six-Cylinder Engines				
Top	35	30-40	47	41-54
Bottom	45	40-50	61	54-68
Eight-Cylinder Engines				
Top	30	25-35	41	34-47
Bottom	30	25-35	41	34-47
Clutch Housing-to-Engine Bolts:				
Four-Cylinder - All	54	46-62	73	62-84
Clutch Housing to Engine Dowel Bolt Nut (6- and 8-Cylinder)	45	40-50	61	54-68
Clutch Housing-to-Transmission Bolts:				
Four-Cylinder	54	46-62	73	62-84
Clutch, Hydraulic Fluid Line Fitting to Master Cylinder		132 in-lbs		120-144 in-lbs
Clutch, Hydraulic Fluid Line Fitting to Slave Cylinder		190 in-lbs		160-220 in-lbs
Clutch Pedal Rebound Bumper, Bolt, Nut, and Lockwasher Assembly to Pedal	40	35-45	54	47-61
Clutch Pedal Shaft Locknut	33	30-36	45	41-49
Flywheel-to-Crankshaft Bolts:				
Four-Cylinder	65	59-71	88	80-96
Rear Crossmember Stud Nuts:				
Four-Cylinder	35	30-40	47	41-54
Starter Motor-to-Clutch Housing Bolt:				
Four-Cylinder	54	46-62	73	62-84
Six- and Eight-Cylinder	18	12-25	24	16-34
Transmission Case to Clutch Housing Bolt	55	50-60	74	68-81
Transmission Support Cushion-to-Crossmember Bolt:				
Four-Cylinder	25	20-30	34	27-41

All Torque values given in foot-pounds and newton-meters with dry fits unless otherwise specified. Refer to Standard Torque Specifications and Capscrew Markings Chart in Section A of this manual for any torque specifications not listed above. 50568

Tools

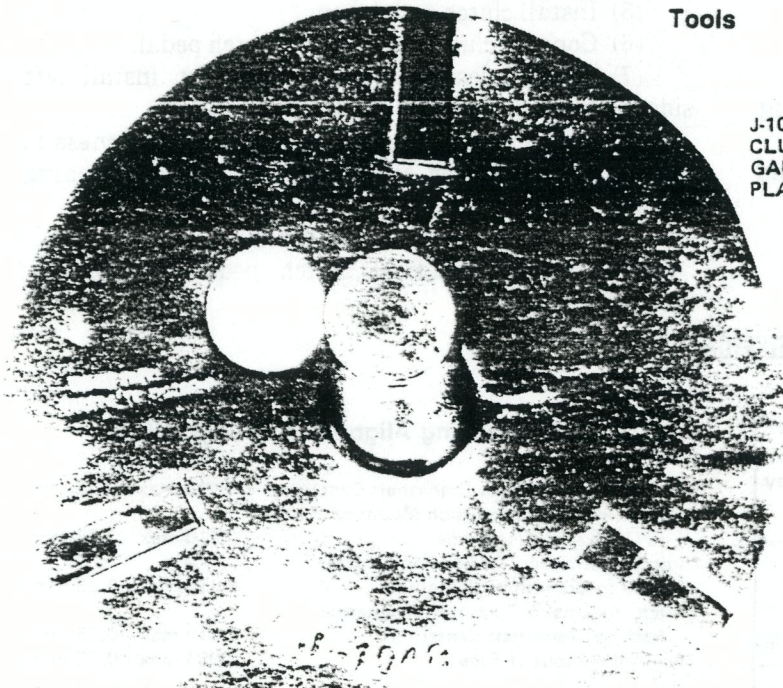

J-1048 CLUTCH GAUGE PLATE

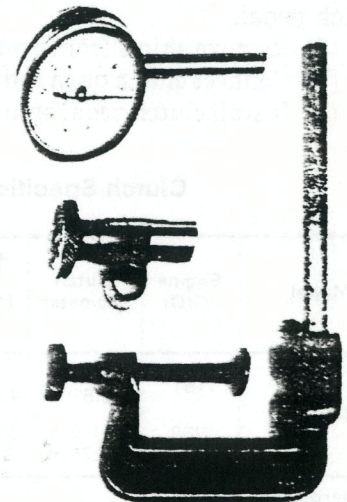

J-8001 DIAL INDICATOR SET

Tools



J-22056 OR J-25353
ALIGNING
TOOL

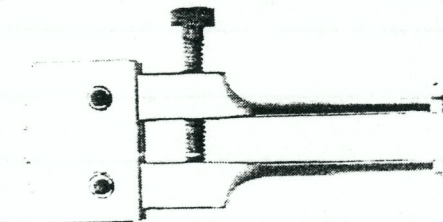

REMOVER TOOL
J-5822

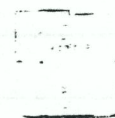

J-23330
CLUTCH LEVER
HEIGHT GAUGE



SLIDE HAMMER
J-2619-01

NOTES

Lined writing area with horizontal lines and three binder holes on the right side.

MANUAL TRANSMISSION

2B

SECTION INDEX

	Page		Page
General Information	2B-1	Model T-18A 4-Speed	2B-24
Model SR-4 4-Speed	2B-6	Tools	2B-33
Model T-176 4-Speed	2B-15		

GENERAL INFORMATION

	Page		Page
Backup Lamp Switch	2B-1	Transmission Gear Ratios	2B-1
Gearshift Patterns	2B-1	Transmission Installation	2B-5
General	2B-1	Transmission Lubricants	2B-4
Identification	2B-1	Transmission Removal	2B-4
Service Diagnosis	2B-2		

GENERAL

Three manual transmission models are used in Jeep vehicles; they are Models SR-4, T-176, and T-18A.

Models SR-4 and T-176 are 4-speed, constant mesh units providing synchromesh engagement in all forward gear ranges. Model T-18A is a 4-speed, constant mesh unit providing synchromesh engagement in second, third, and fourth gear ranges only. First (low) gear is not synchronized in this transmission.

Model SR-4 is used with four- and six-cylinder engines. Model T-176 is used with six- and eight-cylinder engines. Model T-18A is used in J-20 Truck models only.

The three transmission models are all floor shift units. Column shift units are not available in any Jeep model.

The shift mechanism on all transmission models is located within the shift control housing which also serves as the transmission top cover. The shift mechanism does not require adjustment and can be serviced independently of the transmission.

GEARSHIFT PATTERNS

The gearshift pattern for each transmission model is shown in the Gearshift Pattern Chart. Forward gear

ranges for each model are in a standard "H" configuration. However, reverse gear position differs between them. The SR-4 requires that the lever be pressed downward first before moving into the reverse position.

BACKUP LAMP SWITCH

A spring and plunger-type backup lamp switch is used on all models. The switch is located in the shift control housing and is actuated by the reverse shift rail. The switch does not require adjustment and is serviced as an assembly only.

IDENTIFICATION

An identification tag displaying the Jeep part number is attached to the shift control housing. The information on this tag is necessary to obtain correct replacement parts should replacement become necessary. Be sure the tag is securely attached in the original location after completing all service operations.

TRANSMISSION GEAR RATIOS

Different ratio gear sets are used in SR-4 and T-176 transmissions. The ratios used for six- and eight-cylinder engine applications are not the same. Refer to the Transmission Gear Ratio Chart at the end of this section for ratio applications.

Service Diagnosis

Condition	Possible Cause	Correction
TRANSMISSION SHIFTS HARD	<ul style="list-style-type: none"> (1) Clutch adjustment incorrect (2) Clutch linkage or cable binding (3) Shift rail binding (4) Internal bind in transmission caused by shift forks, selector plates, or synchronizer assemblies (5) Clutch housing misalignment (6) Incorrect lubricant (7) Block rings and/or cone seats worn 	<ul style="list-style-type: none"> (1) Adjust clutch. (2) Lubricate or repair as necessary. (3) Check for mispositioned selector arm roll pin, loose cover bolts, worn shift rail bores, worn shift rail, distorted oil seal, or extension housing not aligned with case. Repair as necessary. (4) Remove, disassemble and inspect transmission. Replace worn or damaged components as necessary. (5) Check runout at rear face of clutch housing. Correct runout as outlined in Chapter 2A. (6) Drain and refill transmission. (7) Blocking ring to gear clutch tooth face clearance must be 0.030 inch or greater. If clearance is correct it may still be necessary to inspect blocking rings and cone seats for excessive wear. Repair as necessary.
GEAR CLASH WHEN SHIFTING FROM ONE GEAR TO ANOTHER	<ul style="list-style-type: none"> (1) Clutch adjustment incorrect (2) Clutch linkage or cable binding (3) Clutch housing misalignment (4) Lubricant level low or incorrect lubricant (5) Gearshift components, or synchronizer assemblies worn or damaged 	<ul style="list-style-type: none"> (1) Adjust Clutch. (2) Lubricate or repair as necessary. (3) Check runout at rear of clutch housing. Correct runout as outlined in Chapter 2A (4) Drain and refill transmission and check for lubricant leaks if level was low. Repair as necessary. (5) Remove, disassemble and inspect transmission. Replace worn or damaged components as necessary.
TRANSMISSION NOISY	<ul style="list-style-type: none"> (1) Lubricant level low or incorrect lubricant (2) Clutch housing-to-engine, or transmission-to-clutch housing bolts loose (3) Dirt, chips, foreign material in transmission (4) Gearshift mechanism, transmission gears, or bearing components worn or damaged (5) Clutch housing misalignment 	<ul style="list-style-type: none"> (1) Drain and refill transmission. If lubricant level was low, check for leaks and repair as necessary. (2) Check and correct bolt torque as necessary. (3) Drain, flush, and refill transmission. (4) Remove, disassemble and inspect transmission. Replace worn or damaged components as necessary. (5) Check runout at rear face of clutch housing. Correct runout as outlined in Chapter 2A.

Condition	Possible Cause	Correction
JUMPS OUT OF GEAR	<ul style="list-style-type: none"> (1) Clutch housing misalignment (2) Gearshift lever loose (3) Offset lever nylon insert worn or lever attaching nut loose (4) Gearshift mechanism, shift forks, selector plates, interlock plate, selector arm, shift rail, detent plugs, springs or shift cover worn or damaged (5) Clutch shaft or roller bearings worn or damaged (6) Gear teeth worn or tapered, synchronizer assemblies worn or damaged, excessive end play caused by worn thrust washers or output shaft gears (7) Pilot bushing worn 	<ul style="list-style-type: none"> (1) Check runout at rear face of clutch housing. Correct runout as outlined in Chapter 2A. (2) Check lever for worn fork. Tighten loose attaching bolts. (3) Remove gearshift lever and check for loose offset lever nut or worn insert. Repair or replace as necessary. (4) Remove, disassemble and inspect transmission cover assembly. Replace worn or damaged components as necessary. (5) Replace clutch shaft or roller bearings as necessary. (6) Remove, disassemble, and inspect transmission. Replace worn or damaged components as necessary. (7) Replace pilot bushing.
WILL NOT SHIFT INTO ONE GEAR	<ul style="list-style-type: none"> (1) Gearshift selector plates, interlock plate, or selector arm, worn, damaged, or incorrectly assembled (2) Shift rail detent plunger worn, spring broken, or plug loose (3) Gearshift lever worn or damaged (4) Synchronizer sleeves or hubs, damaged or worn 	<ul style="list-style-type: none"> (1) Remove, disassemble, and inspect transmission cover assembly. Repair or replace components as necessary. (2) Tighten plug or replace worn or damaged components as necessary. (3) Replace gearshift lever. (4) Remove, disassemble and inspect transmission. Replace worn or damaged components.
LOCKED IN ONE GEAR — CAN NOT BE SHIFTED OUT	<ul style="list-style-type: none"> (1) Shift rail(s) worn or broken, shifter fork bent, setscrew loose, center detent plug missing or worn (2) Broken gear teeth on countershaft gear, clutch shaft, or reverse idler gear (3) Gearshift lever broken or worn, shift mechanism in cover incorrectly assembled or broken, worn damaged gear train components 	<ul style="list-style-type: none"> (1) Inspect and replace worn or damaged parts. (2) Inspect and replace damaged part. (3) Disassemble transmission. Replace damaged parts or assemble correctly.

Gearshift Pattern Chart

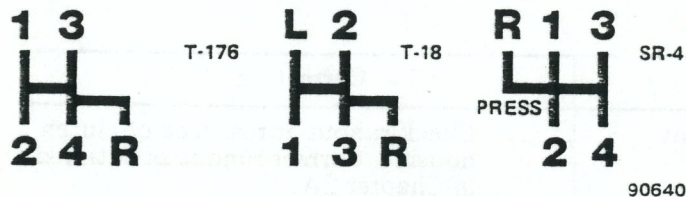

TRANSMISSION LUBRICANT

The recommended lubricant for all transmission models is SAE 85W-90, A.P.I. classification GL-5 Gear Lubricant. This lubricant grade should be used during all service and maintenance operations.

NOTE: Do not use gear lubricants containing lead, chlorine, or sulphur compounds.

When refilling or adding lubricant to the transmission, fill the transmission until the lubricant level is at the lower edge of the fill plug hole only. Lubricant capacities for the three transmission models are:

- SR-4—3.0 Pints (1.4 liters).
- T-176—3.5 Pints (1.7 liters).
- T-18A—6.5 Pints (3.07 liters).

TRANSMISSION REMOVAL

(1) Remove screws attaching transmission shift lever boot to floorpan and slide boot upward on lever.

(2) On models with SR-4 transmission, remove bolts attaching transmission shift lever housing to transmission. Lift shift lever and housing upward and secure assembly to floorpan with wire.

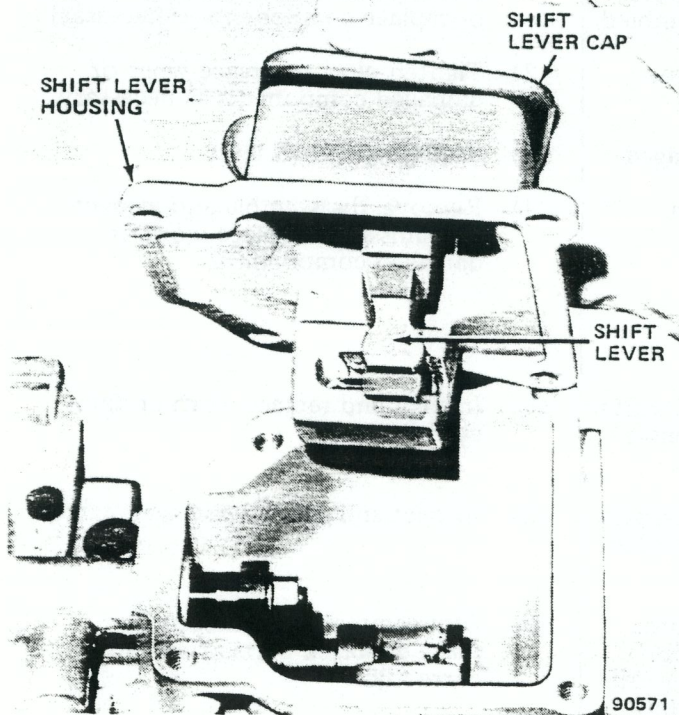

Fig. 2B-1 Shift Lever Removal—Model SR-4

(3) On models with T-18A transmission, unthread shift lever cap and remove cap, gasket, spring seat, spring and shift lever as assembly. Remove shift lever locating pin from housing.

(4) On models with T-176 transmission, press and turn transmission shift lever retainer to release lever. Remove lever, boot, spring and seat as assembly.

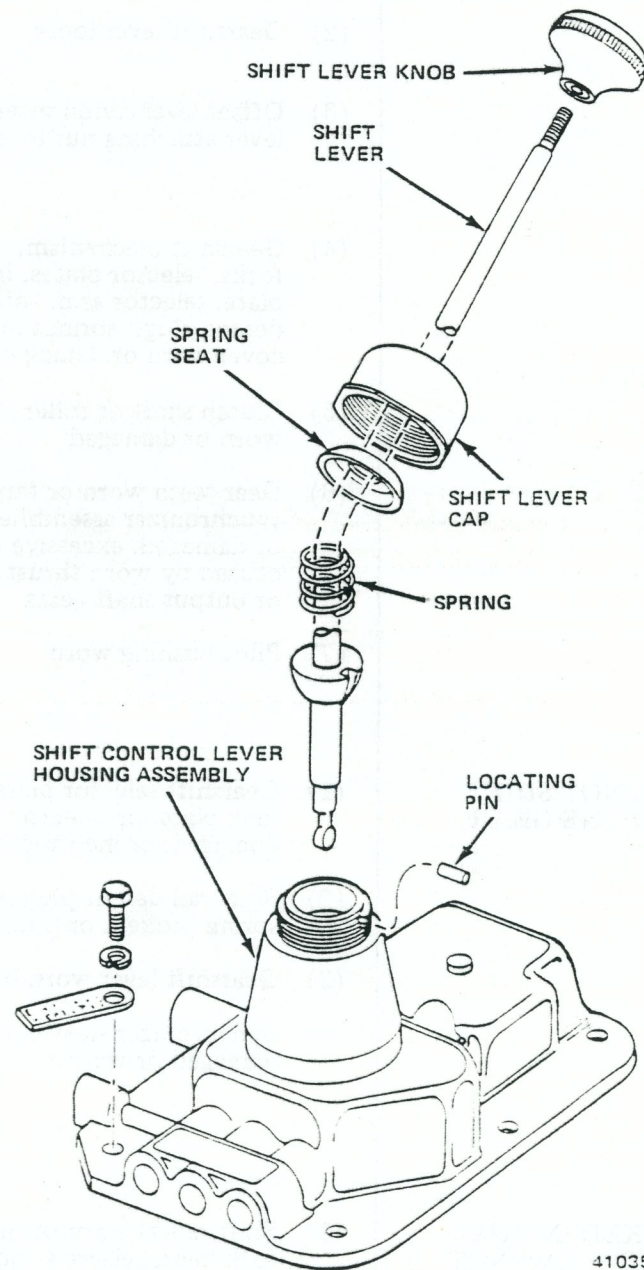

Fig. 2B-2 Shift Lever Removal—Model T-18A

- (5) Raise vehicle.
- (6) Mark rear propeller shaft and transfer case yoke for assembly alignment reference.
- (7) Disconnect rear propeller shaft at transfer case yoke. Move shaft aside and secure to underbody with wire.

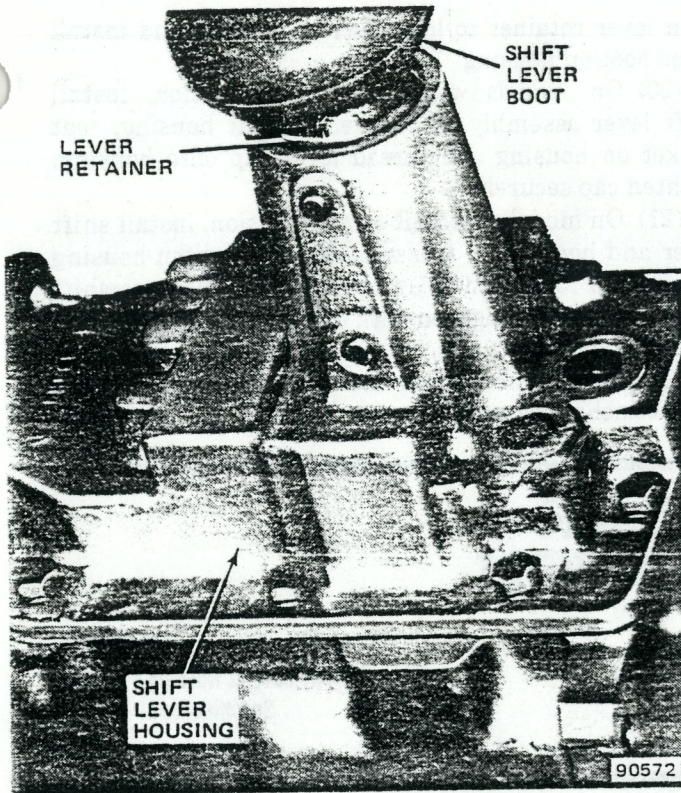

Fig. 2B-3 Shift Lever Removal—Model T-176

(8) On Cherokee and Truck models, disconnect front parking brake cable at equalizer. Remove clip that retains rear cable to rear crossmember and move cable aside.

(9) Position safety stand under clutch housing to support engine.

(10) Remove nuts and bolts attaching rear crossmember to frame rails and rear support cushion and remove crossmember.

(11) Disconnect speedometer cable.

(12) Disconnect backup light switch wire.

(13) Disconnect four-wheel drive indicator switch wire.

(14) Disconnect transfer case vent hose at transfer case.

(15) Mark front propeller shaft and transfer case yoke for assembly alignment reference.

(16) Disconnect front propeller shaft from transfer case yoke. Move shaft aside and secure to underbody with wire.

(17) On CJ models, remove transfer case shift lever as follows: Remove shifter shaft retaining nut. Remove cotter pins that retain shift control link pins in shift rods and remove pins. Remove shifter shaft and disengage shift lever from shift control links. Slide lever upward in boot to move lever out of way.

NOTE: On some models, the shifter shaft must be unthreaded from the shift lever in order to remove it. On other models, the shaft can be removed simply by sliding it out of the lever.

(18) On Cherokee and Truck models, remove cotter pin and washers that connect link to shift lever and disconnect link from shift lever.

(19) Support transmission-transfer case assembly with transmission jack. Use safety chain to secure assembly on jack.

(20) Remove bolts attaching transmission to clutch housing and remove transmission-transfer case assembly.

(21) Remove bolts attaching transfer case to transmission and remove transfer case.

(22) Clean old gasket material and sealer from mating surfaces of transmission and transfer case.

(23) Remove pilot bushing lubricating wick from bushing and soak wick in engine oil. Use long needle-nose pliers to remove wick from bushing.

TRANSMISSION INSTALLATION

(1) Install pilot bushing lubricating wick and align throwout bearing with splines in driven plate hub.

(2) Shift transmission into gear using shift lever or long screwdriver. This prevents clutch shaft from rotating during installation and makes clutch shaft-to-driven plate spline alignment easier.

(3) Mount transmission on transmission jack. Raise transmission and align transmission clutch shaft with splines in driven plate hub.

(4) Install transmission. When transmission is seated on clutch housing, install and tighten transmission-to-clutch housing bolts to 55 foot-pounds (75 N•m) torque.

(5) Apply Permatex Number 3 sealer, or equivalent, to both sides of replacement transmission-to-transfer case gasket and position gasket on transfer case.

(6) Mount transfer case on transmission jack. Raise transfer case and align transmission output shaft and transfer case input shaft splines.

(7) Install transfer case on transmission. On CJ models, install and tighten transfer case attaching bolts to 30 foot-pounds (41 N•m) torque. On Cherokee and Truck models, install and tighten transfer case attaching stud nuts to 40 foot-pounds (54 N•m) torque.

(8) On CJ models, install transfer case shift lever, shifter shaft, link pins and control link assembly. On Cherokee and Truck models, connect shift lever link to operating lever on transfer case.

(9) Connect front propeller shaft to transfer case yoke. Tighten clamp strap bolts to 15 foot-pounds (20 N•m) torque. Be sure shaft and yoke are aligned according to reference marks made at disassembly.

(10) Connect vent hose to transfer case.

(11) Connect wire to four-wheel drive indicator switch.

(12) Connect speedometer cable.

(13) Install rear crossmember. Tighten crossmember attaching nuts and bolts to 30 foot-pounds (41 N•m) torque.

- (14) Remove safety stand used to support engine.
- (15) On Cherokee and Truck models, connect parking brake rear cable to clip that retains cable on crossmember, and connect front cable to equalizer.
- (16) Connect rear propeller shaft to transfer case yoke. Tighten clamp strap bolts to 15 foot-pounds (20 N•m) torque. Be sure shaft and yoke are aligned according to reference marks made at disassembly.
- (17) Check and correct transmission and transfer case lubricant levels, if necessary.
- (18) Lower vehicle.
- (19) On models with T-176 transmission, install shift lever assembly. Seat lever in shift housing, press and

turn lever retainer to lock lever in housing and install lever boot on housing.

(20) On models with T-18A transmission, install shift lever assembly. Seat lever in shift housing, seat gasket on housing and thread lever cap onto housing. Tighten cap securely.

(21) On models with SR-4 transmission, install shift lever and housing on transmission and tighten housing bolts to 10 foot-pounds (14 N•m) torque. Be sure shift lever is properly engaged with offset lever before tightening housing bolts.

(22) Position shift lever boot on floorpan and install boot attaching screws.

MODEL SR-4 4-SPEED TRANSMISSION

	Page
Assembly	2B-10
Cleaning and Inspection	2B-7
Disassembly	2B-6

	Page
Shift Control Housing	2B-12
Specifications	2B-14

DISASSEMBLY

- (1) Remove bolts attaching transfer case to transmission.
- (2) Remove transfer case from transmission.
- (3) Place drain pan under transmission and adapter housing.
- (4) Remove drain bolt (fig. 2B-4) and drain lubricant from transmission.
- (5) Remove flanged nut attaching offset lever to shift rail (fig. 2B-5) and remove offset lever.

NOTE: Two of the shift control housing attaching bolts are dowel-type alignment bolts (fig. 2B-6). Note the location of these bolts for assembly reference.

- (8) Remove spring clip that attaches reverse lever to reverse lever pivot bolt (fig. 2B-7).

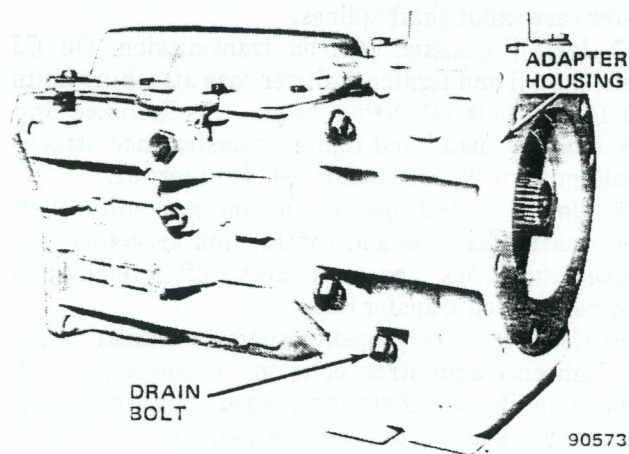

Fig. 2B-4 Drain Bolt Location

- (6) Remove bolts attaching adapter housing to transmission case and remove housing.
- (7) Remove shift control housing and gasket from transmission (fig. 2B-6). Discard gasket.

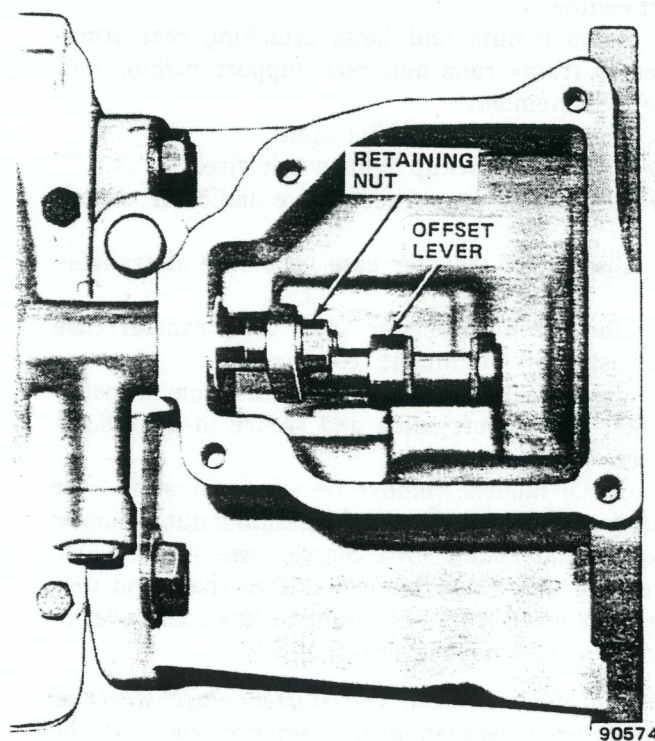
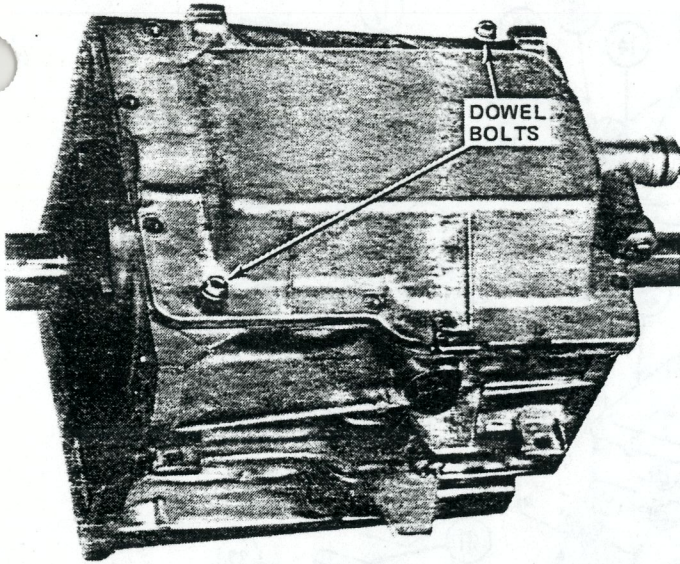

Fig. 2B-5 Offset Lever and Retaining Nut



60799

Fig. 2B-6 Shift Control Housing Dowel Bolt Location

(9) Remove reverse lever pivot bolt (fig. 2B-8) and remove reverse lever and reverse lever fork as assembly.

(10) Punch alignment marks in front bearing cap and transmission case for assembly reference and remove bearing cap and gasket. Discard gasket.

(11) Remove small retaining and large locating snap rings from front and rear bearings.

(12) Remove front bearing from clutch shaft using Bearing Remover J-8157-01, Puller Bolts J-26636 and Puller Assembly J-25152 (fig. 2B-9), and remove clutch shaft from case.

(13) Remove rear bearing from output shaft using Bearing Remover J-8157-01, Puller Bolts J-26827, and Puller Assembly J-25152 (fig. 2B-10).

(14) Remove output shaft and gear train as assembly. Do not allow first-second or third-fourth synchronizer sleeves to separate from hubs during removal.

(15) Push reverse idler gear shaft out rear of case and remove shaft and reverse idler gear.

(16) Remove countershaft from rear of case using Countershaft Loading Tool J-26624 (fig. 2B-11).

(17) Remove countershaft gear and loading tool as assembly and remove countershaft gear thrust washers and any clutch shaft pilot bearings that fell into case during disassembly.

NOTE: *The countershaft gear front thrust washer is plastic. The rear washer is metal.*

(18) Remove countershaft loading tool, needle bearing retainers and 50 needle bearings from countershaft gear.

Disassembly—Output Shaft Gear Train

(1) Scribe alignment marks on third-fourth synchronizer hub and sleeve for assembly alignment reference (fig. 2B-12).

(2) Remove output shaft snap ring (fig. 2B-12) and remove third-fourth synchronizer assembly.

(3) Disassemble third-fourth synchronizer assembly. Remove blocking rings, insert springs and inserts, and separate synchronizer sleeve from hub.

(4) Remove third gear.

(5) Remove second gear retaining snap ring, remove tabbed thrust washer and remove second gear and blocking ring.

(6) Remove first gear thrust washer (fig. 2B-13) and first gear roll pin (fig. 2B-14) from rear of output shaft. Use diagonal cutters to remove roll pin.

NOTE: *The thrust washer has an oil groove and roll pin locating slot on one side. This side must face first gear when assembled.*

(7) Remove first gear and blocking ring.

(8) Scribe alignment marks on first-second synchronizer sleeve and output shaft hub for assembly reference.

(9) Remove insert spring and inserts from first-second sleeve and remove sleeve from output shaft hub.

CAUTION: *Do not attempt to remove the first-second-reverse hub from the output shaft. The hub and shaft are assembled and machined as a matched unit during manufacture to insure concentricity.*

CLEANING AND INSPECTION

Thoroughly wash all parts in solvent and dry them with compressed air. Do not dry the front or rear bearings with compressed air. Allow them to air dry or wipe them dry with a clean shop cloth.

Clean the needle and roller bearings by wrapping them in a cloth and submerging the cloth and bearings in solvent. Or, place them in a shallow parts cleaning tray and cover them with solvent. Allow the bearings to air dry or wipe them dry with a clean shop cloth.

Inspect the transmission case, cover and extension housing. Replace any of these parts if they exhibit the following conditions:

- Cracks in bores, sides, bosses or at bolt holes.
- Stripped threads in bolt holes.
- Nicks, burrs, rough surfaces in shaft bores or on gasket surfaces.

Inspect the gear train and shift mechanism. Replace any parts that exhibit the following conditions:

- Broken, chipped or worn gear teeth.
- Bent or broken inserts.
- Weak or broken insert springs.
- Damaged roller or needle bearings, or bearing bores in countershaft gear or clutch shaft.

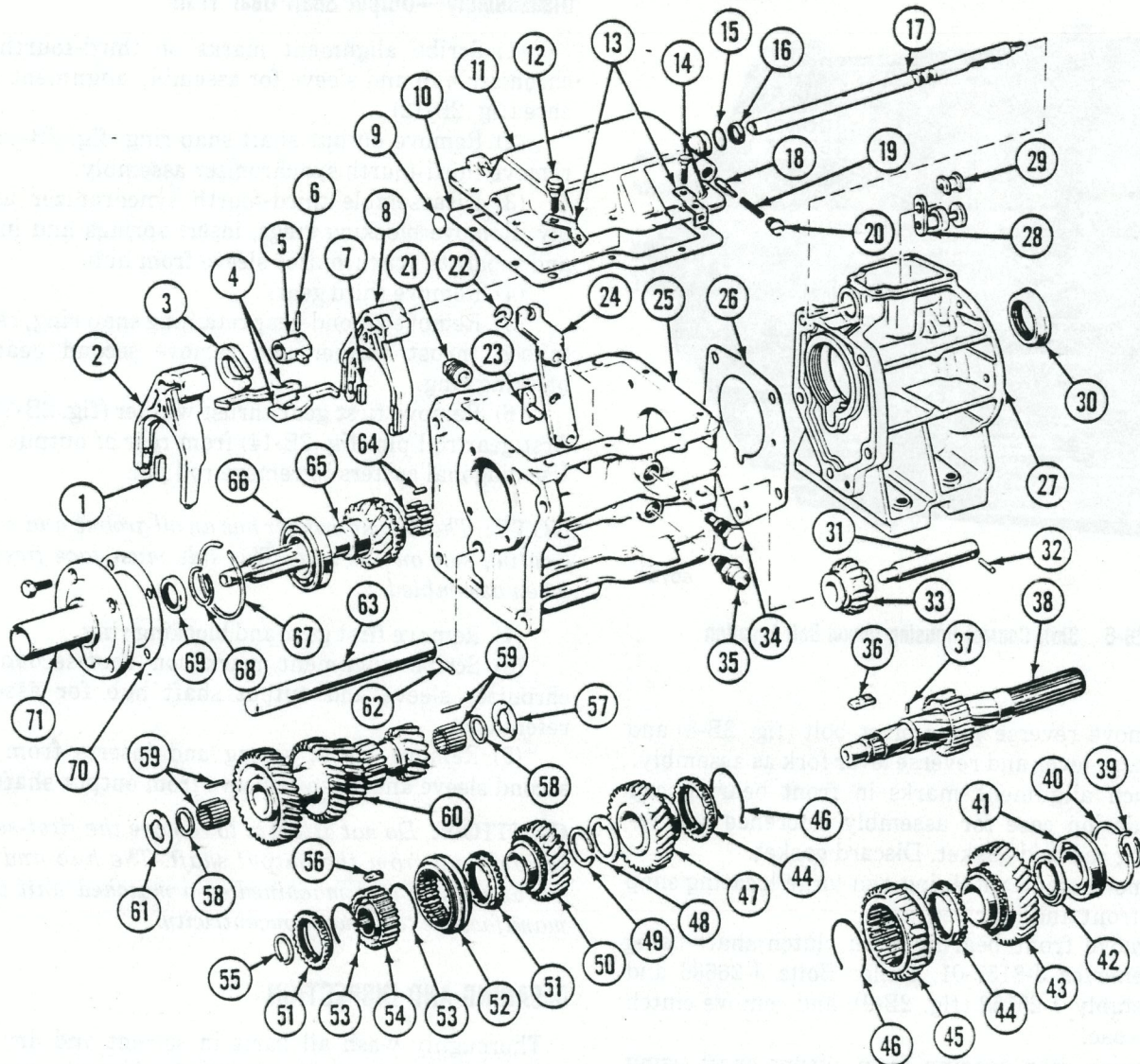

- | | | |
|---|---|--|
| <p>1. THIRD - FOURTH SHIFT INSERT
 2. THIRD - FOURTH SHIFT FORK
 3. SELECTOR INTERLOCK PLATE
 4. SELECTOR ARM PLATE (2)
 5. SELECTOR ARM
 6. SELECTOR ARM ROLL PIN
 7. FIRST - SECOND SHIFT FORK INSERT
 8. FIRST - SECOND SHIFT FORK
 9. SHIFT RAIL PLUG
 10. TRANSMISSION COVER GASKET
 11. TRANSMISSION COVER
 12. TRANSMISSION COVER DOWEL BOLT (2)
 13. CLIP
 14. TRANSMISSION COVER BOLT (8)
 15. SHIFT RAIL O-RING SEAL
 16. SHIFT RAIL OIL SEAL
 17. SHIFT RAIL
 18. DETENT PLUNGER
 19. DETENT SPRING
 20. DETENT PLUG
 21. FILL PLUG
 22. REVERSE LEVER PIVOT BOLT C-CLIP
 23. REVERSE LEVER FORK
 24. REVERSE LEVER
 25. TRANSMISSION CASE
 26. GASKET
 27. ADAPTER HOUSING
 28. OFFSET LEVER
 29. OFFSET LEVER INSERT</p> | <p>30. EXTENSION HOUSING OIL SEAL
 31. REVERSE IDLER SHAFT
 32. REVERSE IDLER SHAFT ROLL PIN
 33. REVERSE IDLER GEAR
 34. REVERSE LEVER PIVOT BOLT
 35. BACKUP LAMP SWITCH
 36. FIRST - SECOND SYNCHRONIZER INSERT (3)
 37. FIRST GEAR ROLL PIN
 38. OUTPUT SHAFT AND HUB ASSEMBLY
 39. REAR BEARING RETAINING SNAP RING
 40. REAR BEARING LOCATING SNAP RING
 41. REAR BEARING
 42. FIRST GEAR THRUST WASHER
 43. FIRST GEAR
 44. FIRST - SECOND SYNCHRONIZER BLOCKING RING (2)
 45. FIRST - REVERSE SLEEVE AND GEAR
 46. FIRST - SECOND SYNCHRONIZER INSERT SPRING (2)
 47. SECOND GEAR
 48. SECOND GEAR THRUST WASHER (TABBED)
 49. SECOND GEAR SNAP RING
 50. THIRD GEAR
 51. THIRD - FOURTH SYNCHRONIZER BLOCKING RING (2)</p> | <p>52. THIRD - FOURTH SYNCHRONIZER SLEEVE
 53. THIRD - FOURTH SYNCHRONIZER INSERT SPRING (2)
 54. THIRD - FOURTH SYNCHRONIZER HUB
 55. OUTPUT SHAFT SNAP RING
 56. THIRD - FOURTH SYNCHRONIZER INSERT (3)
 57. COUNTERSHAFT GEAR REAR THRUST WASHER (METAL)
 58. COUNTERSHAFT NEEDLE BEARING RETAINER (2)
 59. COUNTERSHAFT NEEDLE BEARING (50)
 60. COUNTERSHAFT GEAR
 61. COUNTERSHAFT GEAR FRONT THRUST WASHER (PLASTIC)
 62. COUNTERSHAFT ROLL PIN
 63. COUNTERSHAFT
 64. CLUTCH SHAFT ROLLER BEARINGS (15)
 65. CLUTCH SHAFT
 66. FRONT BEARING
 67. FRONT BEARING LOCATING SNAP RING
 68. FRONT BEARING RETAINING SNAP RING
 69. FRONT BEARING CAP OIL SEAL
 70. FRONT BEARING CAP GASKET
 71. FRONT BEARING CAP</p> |
|---|---|--|

Fig. 2B-7 Model SR-4 4-Speed Transmission

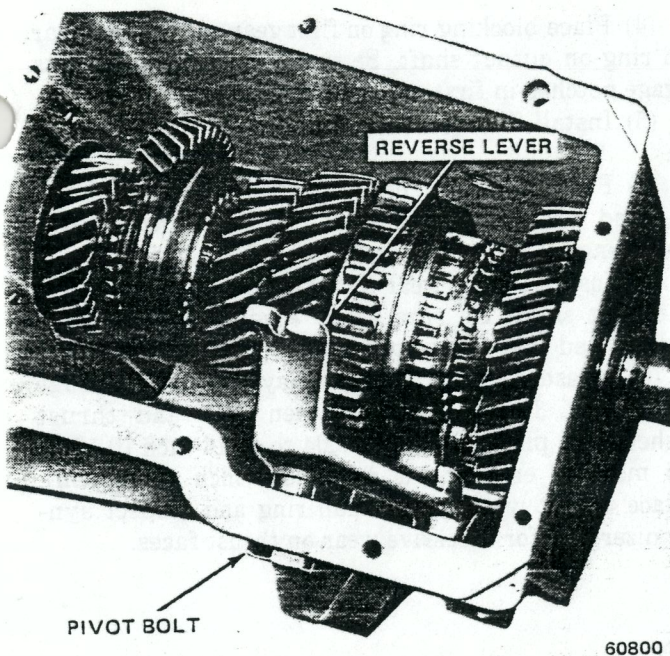

Fig. 2B-8 Reverse Lever and Pivot Bolt

60800

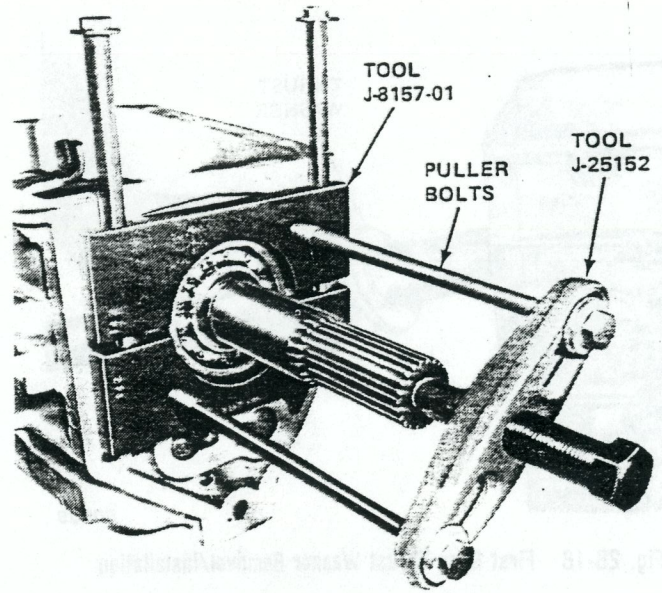

Fig. 2B-10 Rear Bearing Removal

90575

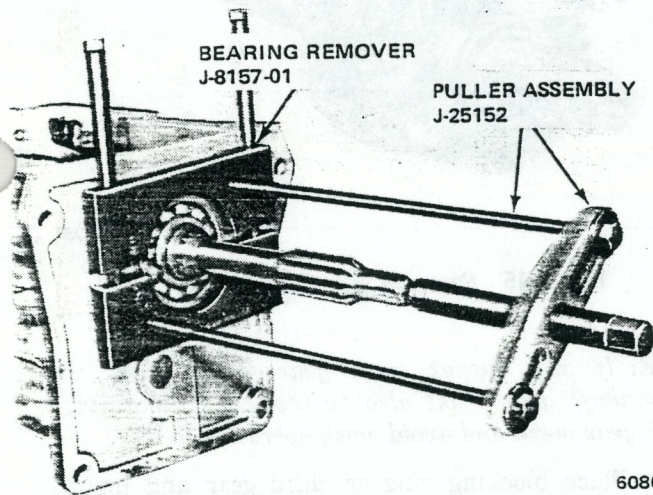

Fig. 2B-9 Front Bearing Removal

60801

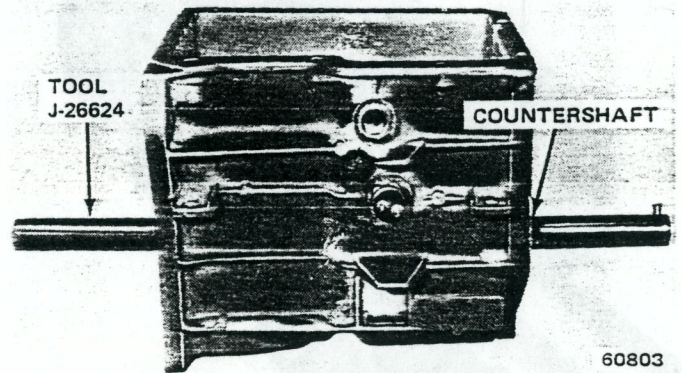

Fig. 2B-11 Countershaft Removal/Installation

60803

- Worn or galled countershaft and hub, clutch shaft or reverse idler gear shaft.
- Worn thrust washers.
- Nicked, broken or worn output or clutch shaft splines.
- Bent, distorted or weak snap rings.
- Worn bushings in reverse idler gear.
- Rough, galled or broken front or rear bearing.
- Worn shift fork inserts.
- Broken, cracked or worn shift forks.
- Bent, worn or galled shift rail.
- Worn, bent or broken selector arms, plates, or interlock.
- Worn, bent, broken or stripped offset lever, or worn lever insert.

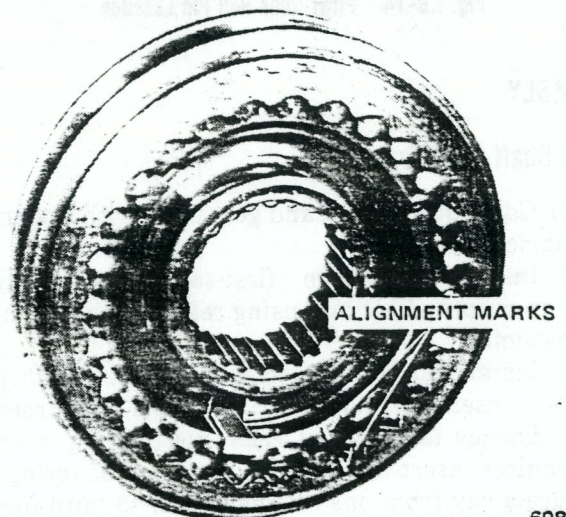
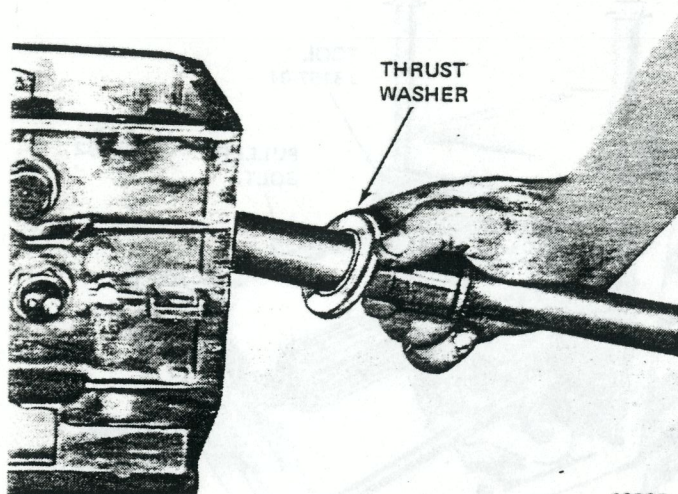

Fig. 2B-12 Marking Synchronizer Assembly

60804



60805

Fig. 2B-13 First Gear Thrust Washer Removal/Installation

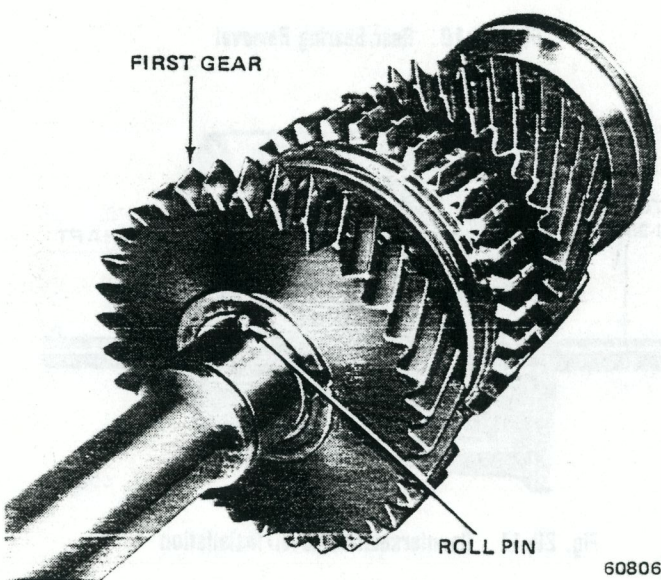

60806

Fig. 2B-14 First Gear Roll Pin Location

ASSEMBLY

Output Shaft Gear Train

(1) Coat output shaft and gear bores with transmission lubricant.

(2) Install and align first-second synchronizer sleeve on output shaft hub using reference marks made at disassembly.

(3) Install three first-second synchronizer inserts and two insert springs in first-second synchronizer sleeve. Engage tang end of each insert spring in same synchronizer insert but position open ends of springs so they face away from one another. Refer to third-fourth synchronizer insert spring assembly illustration (fig. 2B-16).

(4) Place blocking ring on first gear and install gear and ring on output shaft. Be sure synchronizer inserts engage notches in first gear blocking ring.

(5) Install first gear roll pin in output shaft (fig. 2B-14).

(6) Place blocking ring on second gear and install gear and ring on output shaft. Be sure synchronizer inserts engage notches in second gear blocking ring.

(7) Install second gear thrust washer and snap ring on output shaft. Be sure sharp edge of washer faces outward and that tab is engaged in output shaft notch.

(8) Measure second gear end play using feeler gauge (fig. 2B-15). Insert gauge between gear and thrust washer. End play should be 0.004 to 0.014 inch (0.10 to 0.35 mm). If end play is over 0.014 inch (0.35 mm), replace thrust washer and snap ring and inspect synchronizer hub for excessive wear on thrust faces.

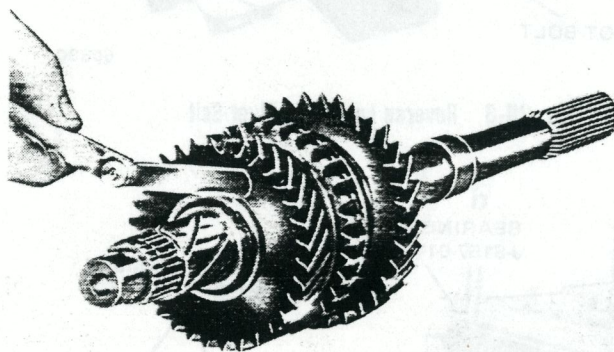

60809

Fig. 2B-15 Measuring Second Gear End Play

NOTE: If any output shaft gear is replaced, the countershaft gear must also be replaced to maintain proper gear mesh and avoid noisy operation.

(9) Place blocking ring on third gear and install gear and ring on output shaft.

(10) Install and align third-fourth synchronizer sleeve on third-fourth synchronizer hub using reference marks made at disassembly.

(11) Install three inserts and two insert springs in third-fourth synchronizer. Engage tang end of each insert spring in same synchronizer insert but position open ends of springs so they face away from one another (fig. 2B-16).

(12) Install assembled third-fourth synchronizer on output shaft with machined groove in synchronizer hub facing forward and install output shaft snap ring. Be sure synchronizer inserts engage notches in third gear blocking rings.

(13) Measure third-fourth synchronizer end play using feeler gauge (fig. 2B-17). Insert gauge between output shaft snap ring and third-fourth synchronizer hub. End play should be 0.004 to 0.014 inch (0.10 to 0.35 mm).

If end play is over 0.014 inch (0.35 mm), replace snap ring and inspect synchronizer hub for excessive wear on thrust faces.

NOTE: If any output shaft gear is replaced, the countershaft gear must also be replaced to maintain proper gear mesh and prevent noisy operation.

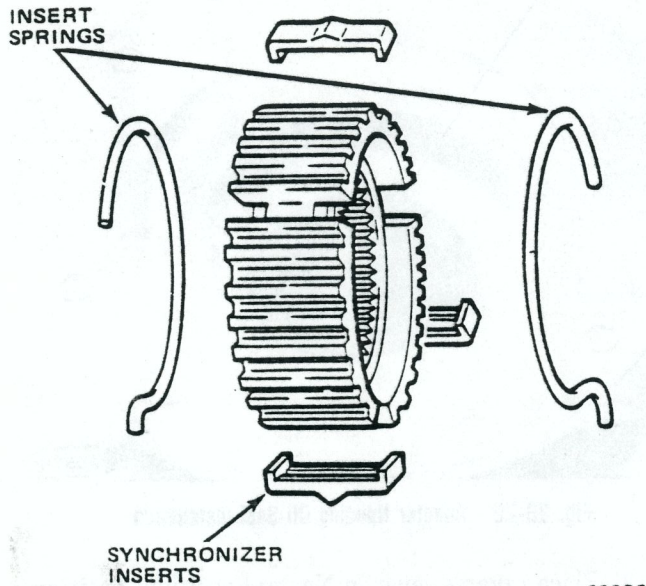

Fig. 2B-16 Third-Fourth Synchronizer Spring Installation

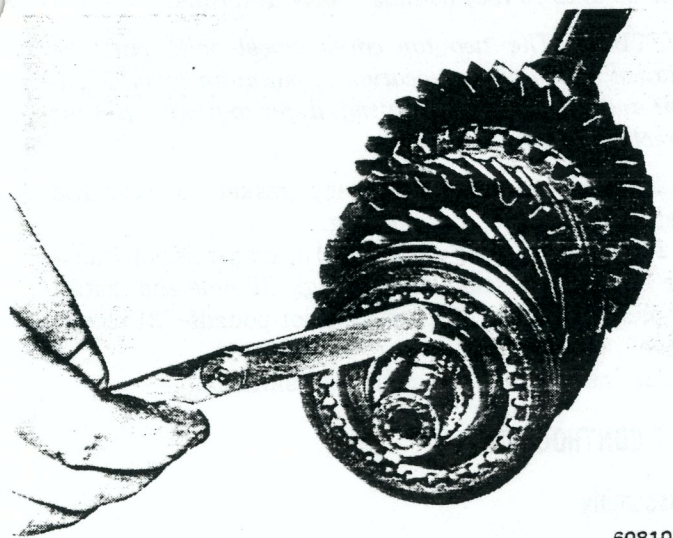

Fig. 2B-17 Measuring Third-Fourth Synchronizer End Play

Transmission Case

CAUTION: Except for the gearshift lever attaching bolts and fill plug, all threaded holes and bolts used in the Model SR-4 Transmission are metric sizes. Do not attempt to substitute a different thread-type bolt if the original ones are lost.

(1) Coat countershaft gear thrust washers with petroleum jelly and position washers in case.

NOTE: Install the plastic washer at the front of the case and the metal washer at the rear.

(2) Insert Countershaft Loading Tool J-26624 in countershaft gear. Install 50 needle bearings in bearing bores at front and rear of gear and install needle bearing retainers. Lubricate bearings with petroleum jelly during installation.

(3) Position assembled countershaft gear in case and install countershaft from rear of case (fig. 2B-11). Be sure that thrust washers are not displaced during installation of countershaft and gear.

(4) Position reverse idler gear in case with shift lever groove facing front of case and install reverse idler shaft from rear of case.

(5) Install output and gear train in case. Do not disturb position of synchronizer assemblies during installation.

(6) Install fourth gear blocking ring in third-fourth synchronizer sleeve. Be sure synchronizer inserts engage notches in blocking ring.

(7) Coat all 15 roller bearings and clutch shaft roller bearing bore with petroleum jelly (only) and install bearings in shaft bore.

(8) Install clutch shaft in case and engage shaft in third-fourth synchronizer sleeve and blocking ring.

(9) Install front bearing using Tool J-22697 (fig. 2B-18). Start front bearing onto clutch shaft. Position output shaft first gear against rear of case. Align bearing with bearing bore in case and drive bearing completely onto clutch shaft and into case.

NOTE: To identify the front and rear bearings, inspect the bearing races. The rear bearing race has a notch in it, while the front bearing race does not.

(10) Install front bearing retaining and locating snap rings.

(11) Install front bearing cap oil seal in front bearing cap using Tool J-26625 (fig. 2B-19).

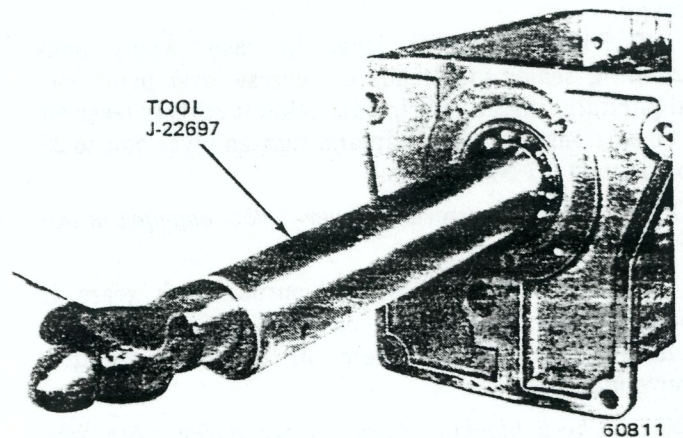
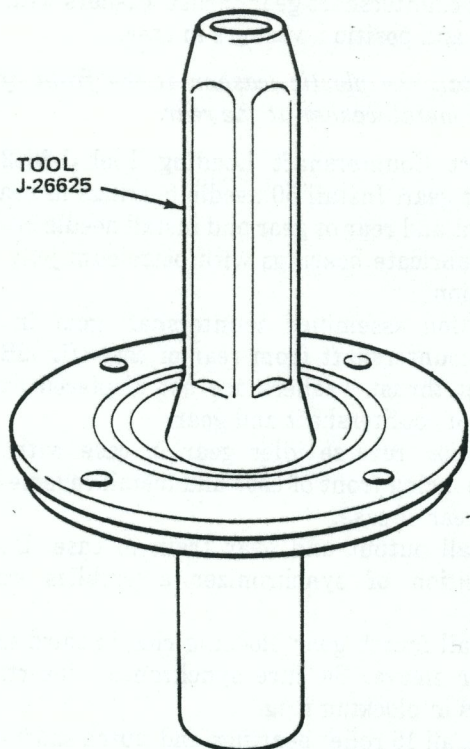

Fig. 2B-18 Bearing Installation



60812

Fig. 2B-19 Front Bearing Cap Seal Installation

(12) Install front bearing cap gasket and front bearing cap. Be sure to align groove in cap and cutout in gasket with oil hole in case. Coat bearing cap bolts with nonhardening sealer and install bolts. Tighten bolts to 13 foot-pounds (18 N•m) torque.

(13) Install first gear thrust washer on output shaft. Be sure side of washer with oil groove faces first gear after installation (fig. 2B-13).

(14) Install rear bearing using Tool J-22697 or J-25234. Refer to figure 2B-18 for procedure.

CAUTION: Be sure the first gear thrust washer is correctly installed and is engaged on the first gear roll pin before installing the rear bearing.

(15) Install retaining and locating snap rings on rear bearing.

(16) Position reverse lever in case. Apply non-hardening sealer to threads of reverse lever pivot bolt and partially install bolt in case. Mount reverse lever on pivot bolt, install spring clip and tighten pivot bolt to 20 foot-pounds (27 N•m) torque.

NOTE: Be sure the reverse lever fork is engaged in the reverse idler gear.

(17) Rotate clutch shaft and output shaft gears. If blocking rings tend to stick on gear cones, release the rings by gently prying them off the cones using a screwdriver.

NOTE: Check blocking ring to gear clutch tooth face clearance. Clearance should be 0.030 inch (0.001 mm) minimum.

(18) Remove adapter housing oil seal using punch or screwdriver. Install new seal so metal face of seal is flush with or slightly below edge of seal bore in housing (fig. 2B-20).

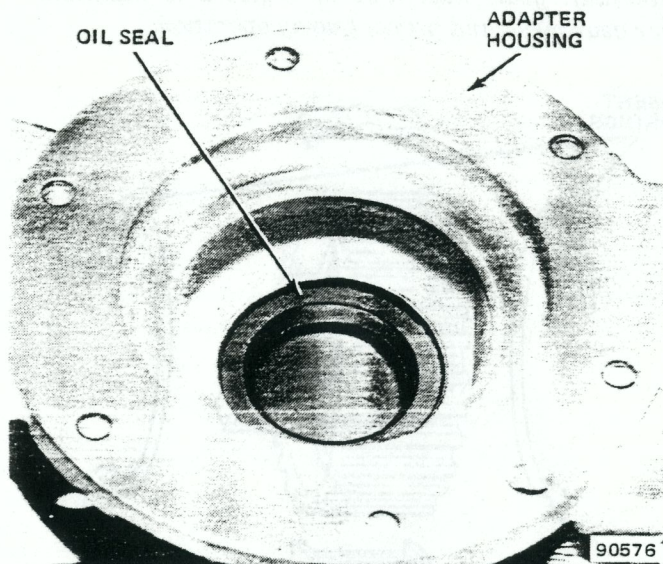

Fig. 2B-20 Adapter Housing Oil Seal Installation

(19) Place reverse lever in Neutral position, position transmission cover gasket and cover assembly on case, and install cover bolts. Alternately and evenly tighten cover bolts to 10 foot-pounds (14 N•m) torque.

CAUTION: The two top cover dowel bolts must be installed in the proper location to maintain cover alignment and prevent hard shifting. Refer to figure 2B-6 for correct bolt location.

(20) Position adapter housing gasket on case and carefully install adapter housing.

(21) Pour 3.0 pints (1.41 liters) of transmission lubricant into transmission case through fill hole and install fill plug. Tighten plug to 23 foot-pounds (31 N•m) torque.

(22) Install transfer case on transmission.

SHIFT CONTROL HOUSING

Disassembly

(1) Remove detent plug, spring and plunger (fig. 2B-21).

(2) Place selector arm plates and shift rail in Neutral position (centered).

(3) Rotate shift rail counterclockwise until selector arm disengages from selector arm plates and selector arm roll pin is accessible (fig. 2B-22).

(4) Pull shift rail rearward until selector arm contacts first-second shift fork.

(5) Remove selector arm roll pin using 3/16-inch (4.76 mm) diameter pin punch and remove shift rail.

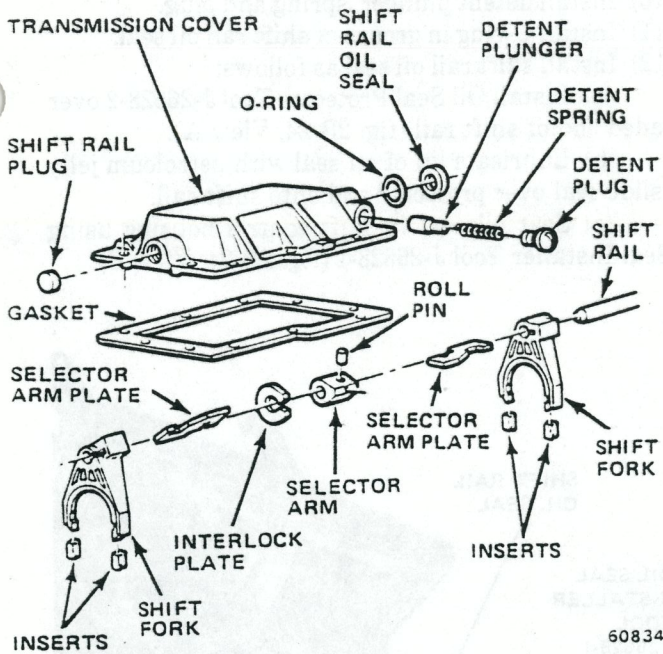

Fig. 2B-21 Shift Control Housing Assembly

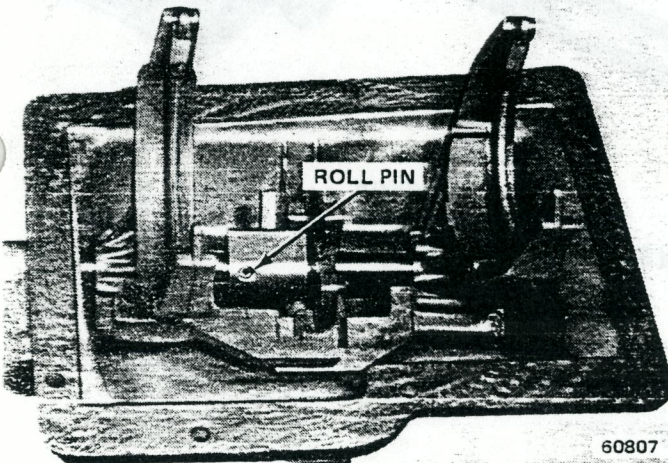

Fig. 2B-22 Roll Pin Location

- Nicks, burrs, rough surfaces in shaft bores or on gasket surfaces.
- Inspect the shift mechanism: Replace any parts that exhibit the following conditions:
- Bent or broken inserts
 - Worn shift fork inserts.
 - Broken, cracked or worn shift forks.
 - Damaged shift rail.
 - Worn or damaged shift rail bores (in housing).
 - Worn, damaged or bent offset lever.
 - Worn, bent or broken selector arms, plates, or interlock.

Assembly

(1) Install nylon inserts and selector arm plates in shift forks (fig. 2B-23).

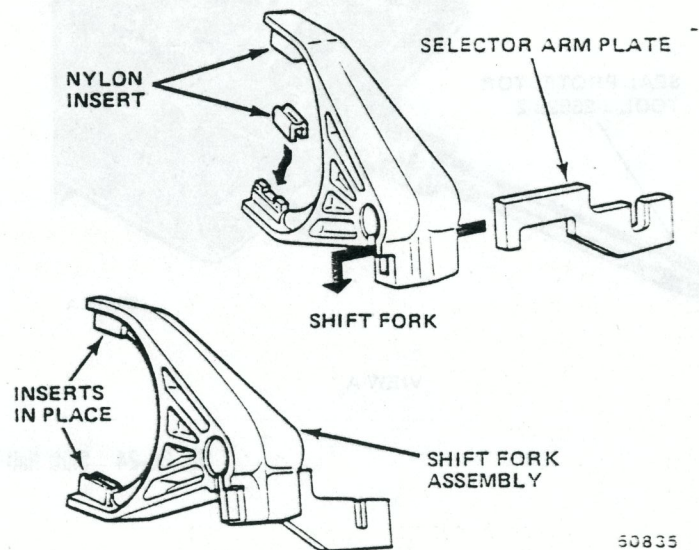

Fig. 2B-23 Assembling Shift Forks and Selector Arm Plates

- (2) Install shift rail plug. Coat edges of plug with sealer before installing.
- (3) Coat shift rail and shift rail bores with petroleum jelly and insert shift rail in cover. Install rail until end of rail is flush with inside edge of cover.
- (4) Position first-second shift fork in cover with fork offset facing rear of cover and push shift rail through fork.

NOTE: *The first-second shift fork is the larger of the two forks.*

(5) Position selector arm and C-shaped interlock plate in cover and insert shift rail through arm. Widest part of interlock plate must face away from cover, and selector arm roll pin hole must face downward and toward rear of cover.

(6) Position third-fourth shift fork in cover with fork offset facing rear of cover. Third-fourth shift fork selector arm plate must be positioned under first-second shift fork selector arm plate.

(6) Remove shift forks, selector arm plates, selector arm and roll pin, and interlock plate.

(7) Remove shift rail oil seal and O-ring using screwdriver.

(8) Remove shift rail plug using hammer and punch.

(9) Remove nylon inserts and selector arm plates from shift forks. Note position of inserts and plates for assembly reference.

Cleaning and Inspection

Thoroughly wash all parts in solvent and dry them with compressed air.

Inspect the shift control housing. Replace the housing if it exhibits the following conditions:

- Cracks in bores, sides, bosses, or at bolt holes.

(7) Insert shift rail through third-fourth shift fork and into front shift rail bore in cover.

(8) Rotate shift rail until selector arm plate at forward end of rail faces away from, but is parallel to cover.

(9) Align roll pin holes in selector arm and shift rail and install roll pin. Be sure roll pin is installed flush with surface of selector arm to prevent pin from contacting selector arm plates during shifts.

(10) Install detent plunger, spring and plug.

(11) Install O-ring in groove of shift rail oil seal.

(12) Install shift rail oil seal as follows:

(a) Install Oil Seal Protector Tool J-26628-2 over threaded end of shift rail (fig. 2B-24, View A).

(b) Lubricate lip of oil seal with petroleum jelly and slide seal over protector and onto shift rail.

(c) Seat oil seal in shift control housing using Oil Seal Installer Tool J-26628-1 (fig. 2B-24, View B).

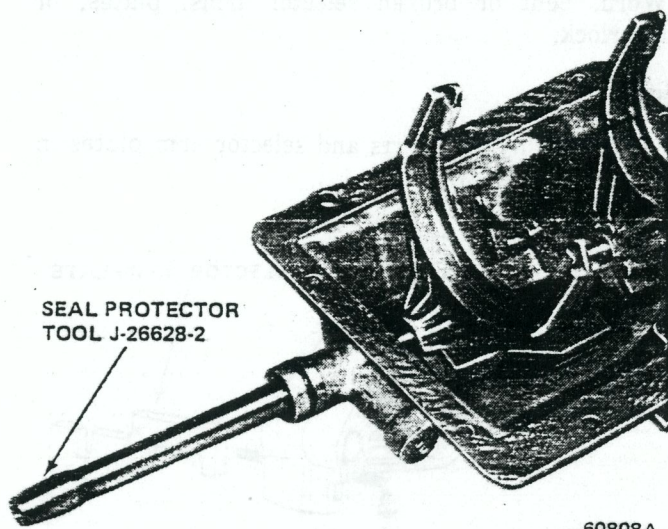

VIEW A

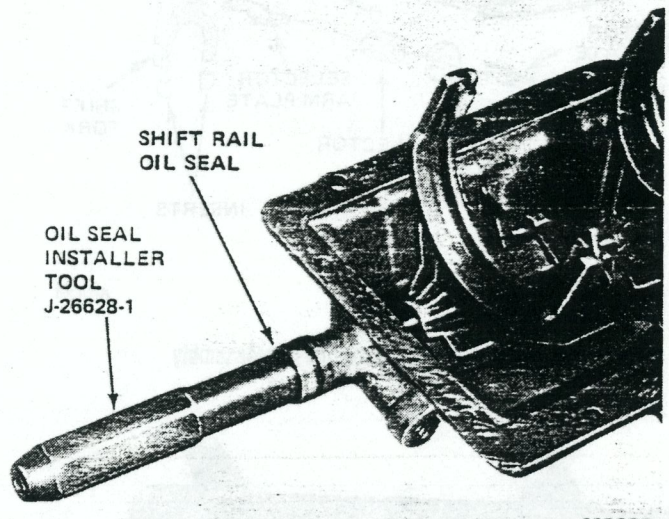

VIEW B

Fig. 2B-24 Shift Rail Oil Seal Installation

SPECIFICATIONS

Transmission Specifications—Model SR-4

Transmission Specifications

End Play Tolerance:

Countershaft Gear End Play	0.004 to 0.018 inch (0.102 to 0.457 mm)
Second Gear End Play	0.004 to 0.014 inch (0.102 to 0.356 mm)
Output Shaft End Play	0.004 to 0.014 inch (0.102 to 0.356 mm)
Blocking Ring to Cone Seat Clearance	0.030 inch min. (0.001 mm)

Lubrication

Level	to bottom of fill hole
Inspect Correct Fill Level	every 5000 miles (8045 km)
Recommended Lubricants	SAE 85W-90

Lubricant Capacity

U.S. Measure	3.0 pints
Imperial Measure	3.5 pints
Metric Measure	1.41 liters

Torque Specifications

Service Set-To Torques should be used when assembling components. Service In-Use Recheck Torques should be used for checking a pre-torqued item.

	USA (ft-lbs)		Metric (N·m)	
	Service Set-To Torque	Service In-Use Recheck Torque	Service Set-To Torque	Service In-Use Recheck Torque
Backup Lamp Switch	10	8-12	14	11-16
Adapter Housing Bolt	23	18-27	31	24-37
Detent Plug (in housing)	10	8-12	14	11-16
Fill Plug	20	15-25	27	20-34
Front Bearing Cap Bolt	13	11-15	18	15-20
Offset Lever Nut	10	8-12	14	11-16
Reverse Lever Pivot Bolt	20	15-25	27	20-34
Shift Control Housing Bolt	10	7-12	14	9-16
Transmission-to-Clutch Housing Bolt	55	45-65	75	61-65
Universal Joint Clamp Strap Bolt	14	12-18	19	16-24

All torque values given in foot-pounds and newton-meters with dry fits unless otherwise specified.

60791

Transmission Gear Ratios

ENGINE-VEHICLE MODEL	T-176					T-18A				
	1st	2nd	3rd	4th	REV.	1st	2nd	3rd	4th	REV.
4-Cylinder CJ-5, CJ-7 (SR-4 Only)	4.07:1	2.39:1	1.49:1	1.00:1	3.95:1					
6-Cylinder CJ-7	4.07:1	2.39:1	1.49:1	1.00:1	3.95:1					
6/8 Cylinder CJ-5, CJ-7	3.82:1	2.29:1	1.46:1	1.00:1	3.52:1					
6-Cylinder Cherokee, J-10 Truck	3.82:1	2.29:1	1.46:1	1.00:1	3.52:1					
8-Cylinder Cherokee, J-10 Truck	3.52:1	2.27:1	1.46:1	1.00:1	3.01:1					
J-20 Truck						6.32:1	3.09:1	1.69:1	1.00:1	7.44:1

90577

**MODEL T-176
4-SPEED TRANSMISSION**

	Page		Page
Assembly	2B-18	Shift Control Housing	2B-22
Cleaning and Inspection	2B-17	Specifications	2B-23
Disassembly	2B-15		

DISASSEMBLY

- (1) Remove bolts attaching transfer case to transmission and remove transfer case.
- (2) Remove shift control housing.

NOTE: Two of the housing attaching bolts are dowel-type alignment bolts. Note the location of these bolts for assembly reference.

- (3) Drain lubricant from transmission case if not drained during removal.

- (4) Remove countershaft using Arbor Tool J-29342 (fig. 2B-25). Tap countershaft out rear of case.
- (5) Remove locating ring and retaining snap ring from rear bearing.
- (6) Remove rear bearing using Puller Set J-25152 (fig. 2B-26).
- (7) Scribe or punch alignment reference marks in front bearing cap and transmission case.
- (8) Remove front bearing cap and gasket.
- (9) Remove and discard front bearing cap oil seal. Use screwdriver to pry seal out of cap.

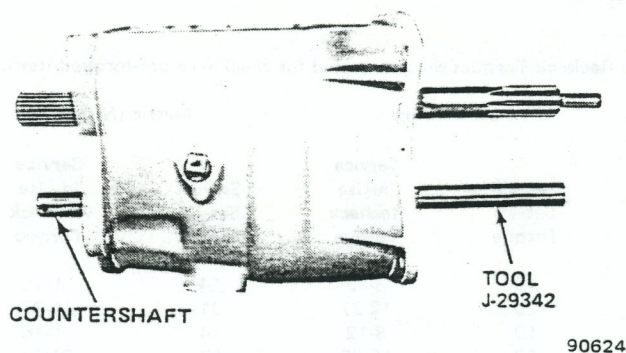

Fig. 2B-25 Countershaft Removal/Installation

(10) Remove locating ring and retaining snap ring from front bearing (fig. 2B-27).

(11) Remove clutch shaft and front bearing using Adapter J-29344 and Puller Set J-25152 (fig. 2B-28).

(12) Remove third-fourth blocking ring from clutch shaft or synchronizer hub.

(13) Remove front bearing from clutch shaft using Puller Set J-25152 (fig. 2B-29).

(14) Remove mainshaft pilot bearing rollers from clutch shaft (fig. 2B-27).

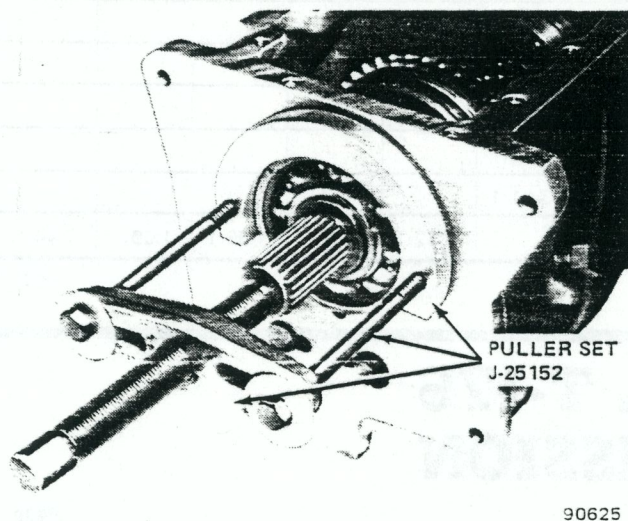

Fig. 2B-26 Rear Bearing Removal

(15) Remove mainshaft and geartrain assembly. Move third-fourth synchronizer sleeve rearward (to third gear position). Tilt rear end of shaft downward and lift front end of shaft upward and out of case.

(16) Remove countershaft gear and arbor tool as assembly.

(17) Remove countershaft gear thrust washers and any mainshaft pilot bearing rollers that may have fallen into case during clutch shaft removal.

(18) Remove reverse idler gear assembly. Tap idler gear shaft out rear of case (fig. 2B-30). Remove gear assembly thrust washers.

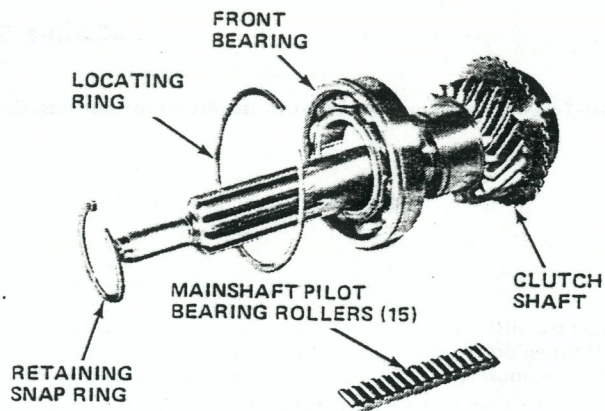

Fig. 2B-27 Clutch Shaft and Front Bearing Assembly

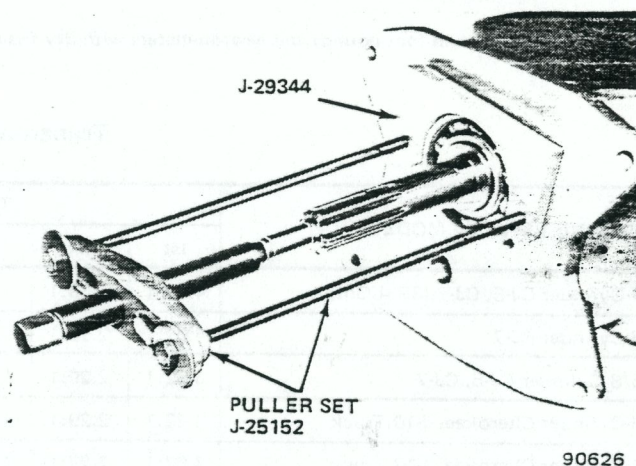

Fig. 2B-28 Clutch Shaft Front Bearing Removal

(19) Remove needle bearings and bearing retainers from gear assembly (fig. 2B-31). Remove sliding gear from idler gear. Note position of sliding gear for assembly reference.

(20) Remove arbor tool from countershaft gear and remove needle bearings and bearing retainers (fig. 2B-32).

Disassembly Mainshaft Geartrain

(1) Remove third-fourth synchronizer snap ring from front end of mainshaft (fig. 2B-33).

(2) Remove third-fourth synchronizer assembly from mainshaft. Slide hub out of sleeve. Remove insert springs and three inserts and blocking ring. Note position of insert springs for assembly reference.

(3) Remove third gear from mainshaft.

(4) Remove second gear snap ring from mainshaft and remove second gear and blocking ring.

(5) Remove tabbed thrust washer from mainshaft (fig. 2B-33).

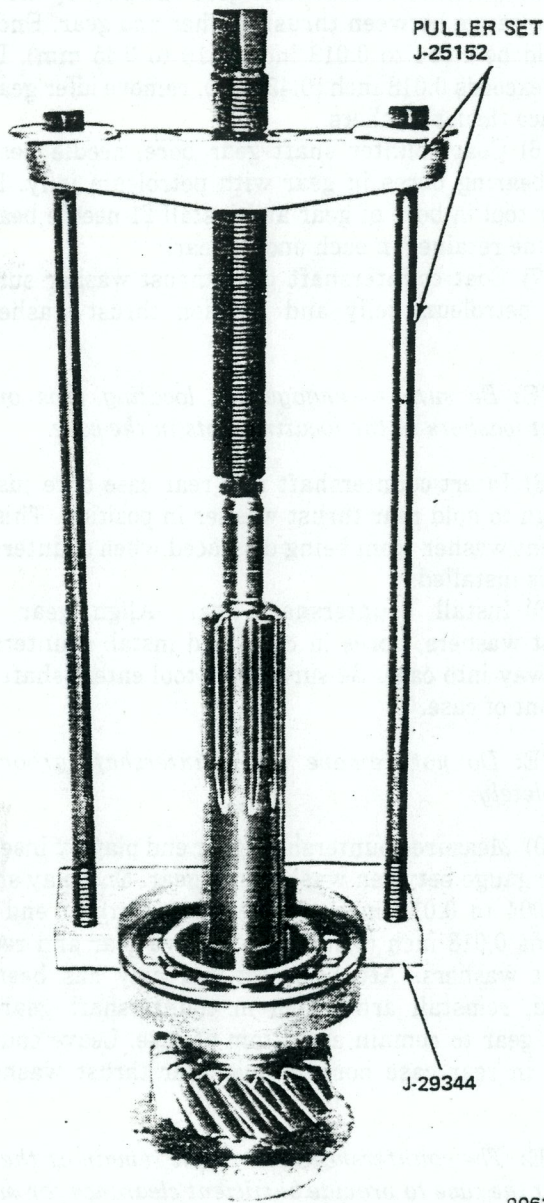

Fig. 2B-29 Removing Front Bearing from Clutch Shaft

(6) Remove snap ring from first-second synchronizer hub. Remove hub and reverse gear and sleeve as assembly. Mark hub and sleeve for assembly reference. Remove insert springs from hub, remove three inserts, and remove sleeve and gear from hub.

(7) Remove first gear thrust washer from rear of shaft and remove first gear and blocking ring (if ring was not removed previously).

CLEANING AND INSPECTION

Cleaning

Thoroughly wash all parts in solvent and dry using compressed air. However, do not dry the bearings with compressed air. Air dry the bearings or wipe them dry using a clean shop cloth only.

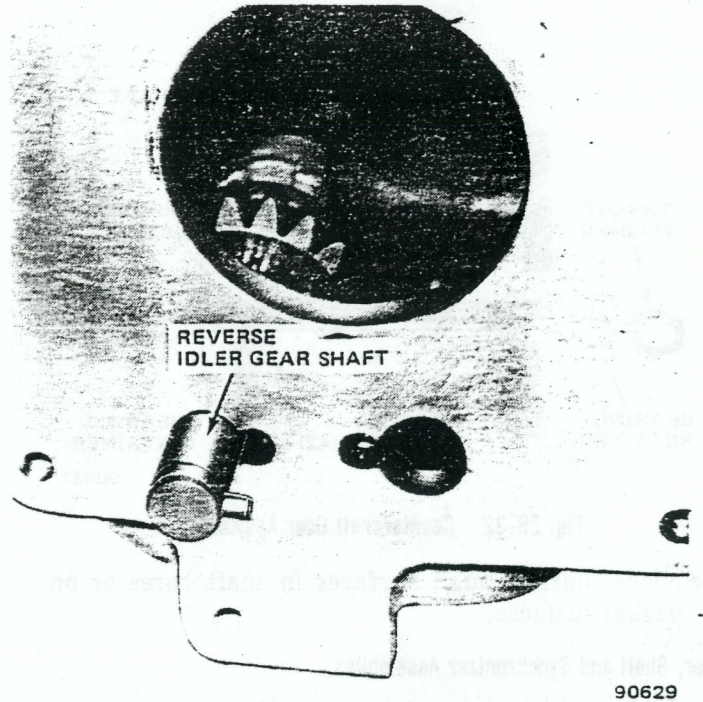

Fig. 2B-30 Reverse Idler Gear Shaft Removal/Installation

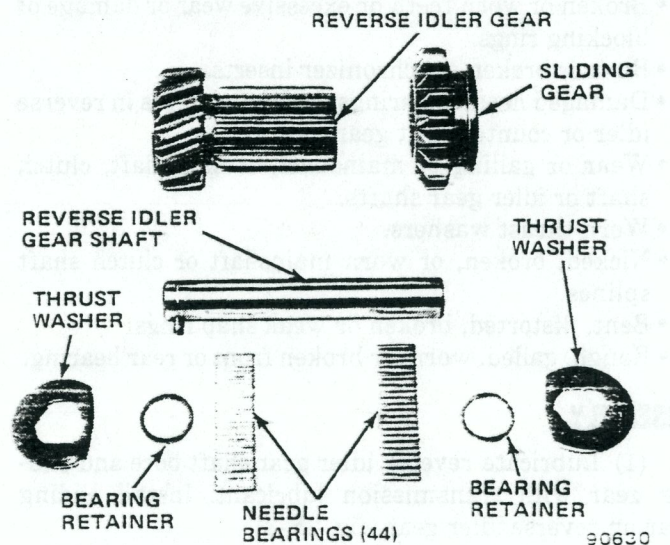

Fig. 2B-31 Reverse Idler Gear Assembly

Clean the needle and clutch shaft roller bearings by wrapping the bearings in a clean cloth and submerging them in solvent. Or, place the bearings in a shallow parts cleaning tray and cover them with solvent. Allow the bearings to air dry on a clean cloth.

Inspection

Inspect the transmission components. Replace any components that exhibit the following conditions:

Case

- Cracks in bores, sides, bosses or at bolt holes.
- Stripped threads in bolt holes.

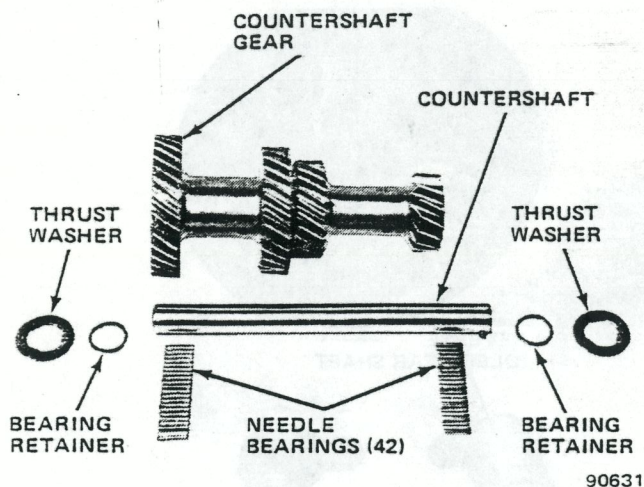

Fig. 2B-32 Countershaft Gear Assembly

- Nicks, burrs, rough surfaces in shaft bores or on gasket surfaces.

Gear, Shaft and Synchronizer Assemblies

- Broken, chipped or worn gear teeth.
- Damaged splines on mainshaft, synchronizer hubs, or sleeves.
- Broken or worn teeth or excessive wear or damage of blocking rings.
- Bent or broken synchronizer inserts.
- Damaged needle bearings or bearing bores in reverse idler or countershaft gear.
- Wear or galling of mainshaft, countershaft, clutch shaft or idler gear shafts.
- Worn thrust washers.
- Nicked, broken, or worn mainshaft or clutch shaft splines.
- Bent, distorted, broken or weak snap rings.
- Rough, galled, worn, or broken front or rear bearing.

ASSEMBLY

(1) Lubricate reverse idler gear shaft bore and sliding gear with transmission lubricant. Install sliding gear on reverse idler gear (fig. 2B-31).

(2) Install Arbor Tool J-29343 in reverse idler gear and install 22 needle bearings and one bearing retainer at each end of gear (fig. 2B-34).

(3) Coat reverse idler gear thrust washer surfaces with petroleum jelly and install thrust washers in case.

NOTE: *The thrust washers have flats on them. Be sure to install the washers so these flats will face the mainshaft. Also, be sure to engage the thrust washer locating tabs in the case locating slots.*

(4) Install reverse idler gear assembly (fig. 2B-35). Align gear bore, thrust washers, case bores, and install reverse idler gear shaft from rear of case. Be sure to seat roll pin in shaft, align roll pin with counterbore in case and push shaft into rear of case (fig. 2B-30).

(5) Measure reverse idler gear end play by inserting feeler gauge between thrust washer and gear. End play should be 0.004 to 0.018 inch (0.10 to 0.45 mm). If end play exceeds 0.018 inch (0.45 mm), remove idler gear and replace thrust washers.

(6) Coat counter shaft gear bore, needle bearings and bearing bores in gear with petroleum jelly. Insert arbor tool in bore of gear and install 21 needle bearings and one retainer in each end of gear.

(7) Coat countershaft gear thrust washer surfaces with petroleum jelly and position thrust washers in case.

NOTE: *Be sure to engage the locating tabs on the thrust washers in the locating slots in the case.*

(8) Insert countershaft into rear case bore just far enough to hold rear thrust washer in position. This will prevent washer from being displaced when countershaft gear is installed.

(9) Install countershaft gear. Align gear bore, thrust washers, bores in case, and install countershaft part-way into case. Be sure arbor tool enters shaft bore at front of case.

NOTE: *Do not remove the countershaft arbor tool completely.*

(10) Measure countershaft gear end play by inserting feeler gauge between washer and gear. End play should be 0.004 to 0.018 inch (0.10 to 0.45 mm). If end play exceeds 0.018 inch (0.45 mm), remove gear and replace thrust washers. After correct end play has been obtained, reinstall arbor tool in countershaft gear and allow gear to remain at bottom of case. Leave countershaft in rear case bore to hold rear thrust washer in place.

NOTE: *The countershaft gear must remain at the bottom of the case to provide sufficient clearance for installation of the mainshaft and clutch shaft assemblies.*

(11) Lubricate mainshaft, synchronizer assemblies and gear bores with transmission lubricant.

(12) Assemble first-second synchronizer hub and reverse gear and sleeve (fig. 2B-33):

(a) Install gear and sleeve on hub and place assembly flat on workbench.

(b) Drop inserts into hub slots.

(c) Install insert spring. Position loop-end of spring in one insert, compress spring ends and insert spring ends under lips of remaining two inserts. Be sure spring is under lip of each insert (fig. 2B-36).

(d) Turn assembly over and install remaining insert spring as described in previous step. However, install this spring so open end faces 180° opposite first spring.

(13) Install assembled first-second synchronizer hub and reverse gear and sleeve on mainshaft.

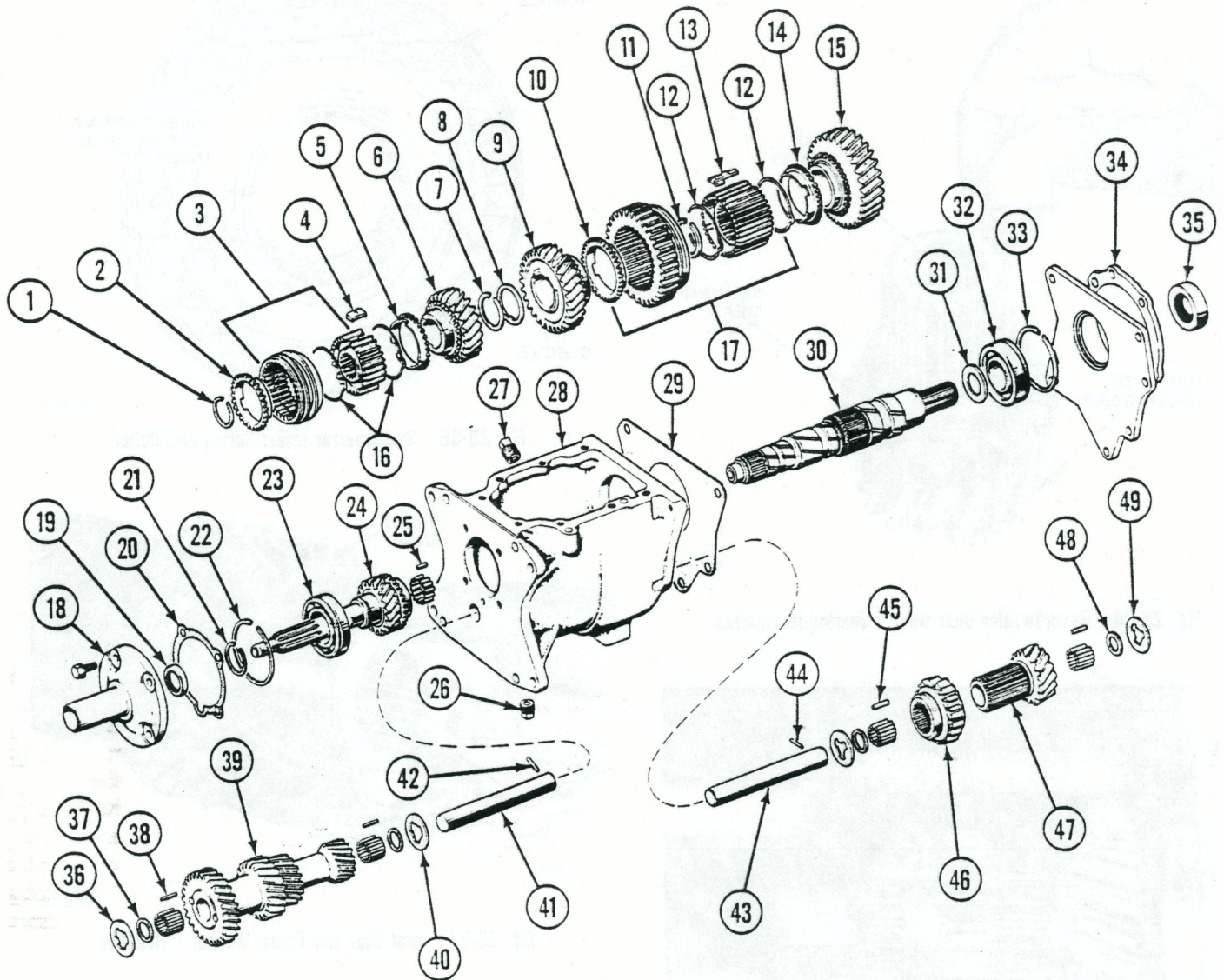

- | | |
|---------------------------------------|---|
| 1. THIRD-FOURTH GEAR SNAP RING | 26. DRAIN PLUG |
| 2. FOURTH GEAR SYNCHRONIZER RING | 27. FILL PLUG |
| 3. THIRD-FOURTH GEAR CLUTCH ASSEMBLY | 28. CASE |
| 4. THIRD-FOURTH GEAR PLATE | 29. GASKET |
| 5. THIRD GEAR SYNCHRONIZER RING | 30. SPLINE SHAFT |
| 6. THIRD SPEED GEAR | 31. FIRST GEAR THRUST WASHER |
| 7. SECOND GEAR SNAP RING | 32. REAR BALL BEARING |
| 8. SECOND GEAR THRUST WASHER | 33. SNAP RING |
| 9. SECOND SPEED GEAR | 34. ADAPTER PLATE |
| 10. SECOND GEAR SYNCHRONIZER RING | 35. ADAPTER SEAL |
| 11. MAIN SHAFT SNAP RING | 36. FRONT COUNTERSHAFT GEAR THRUST WASHER |
| 12. FIRST-SECOND SYNCHRONIZER SPRING | 37. ROLLER WASHER |
| 13. LOW-SECOND PLATE | 38. REAR ROLLER BEARING |
| 14. FIRST GEAR SYNCHRONIZER RING | 39. COUNTERSHAFT GEAR |
| 15. FIRST GEAR | 40. REAR COUNTERSHAFT THRUST WASHER |
| 16. THIRD-FOURTH SYNCHRONIZER SPRING | 41. COUNTERSHAFT |
| 17. FIRST-SECOND GEAR CLUTCH ASSEMBLY | 42. PIN |
| 18. FRONT BEARING CAP | 43. IDLER GEAR SHAFT |
| 19. OIL SEAL | 44. PIN |
| 20. GASKET | 45. IDLER GEAR ROLLER BEARING |
| 21. SNAP RING | 46. REVERSE IDLER SLIDING GEAR |
| 22. LOCK RING | 47. REVERSE IDLER GEAR |
| 23. FRONT BALL BEARING | 48. IDLER GEAR WASHER |
| 24. CLUTCH SHAFT | 49. IDLER GEAR THRUST WASHER |
| 25. ROLLER BEARING | |

Fig. 2B-33 Model T-176 4-Speed Transmission

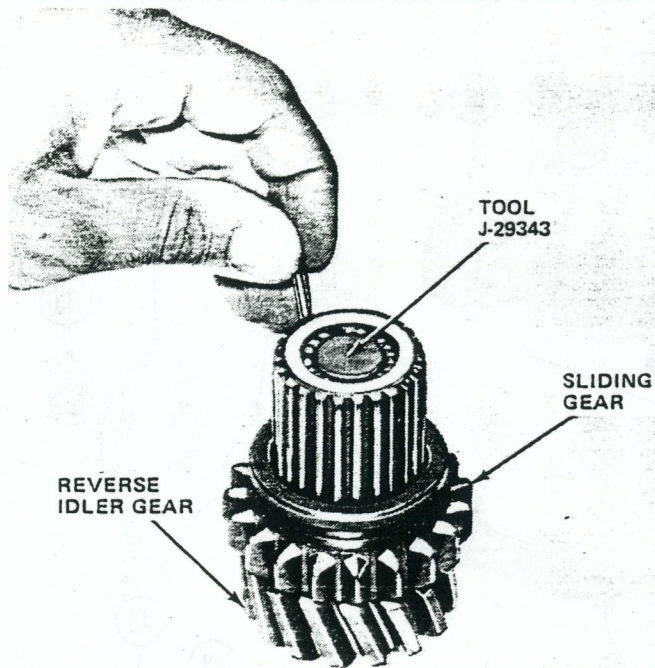

90633

Fig. 2B-34 Reverse Idler Gear Needle Bearing Installation

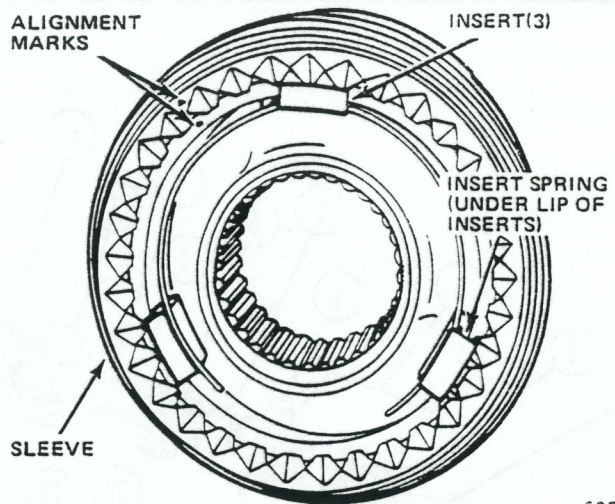

60558

Fig. 2B-36 Synchronizer Insert Spring Installation

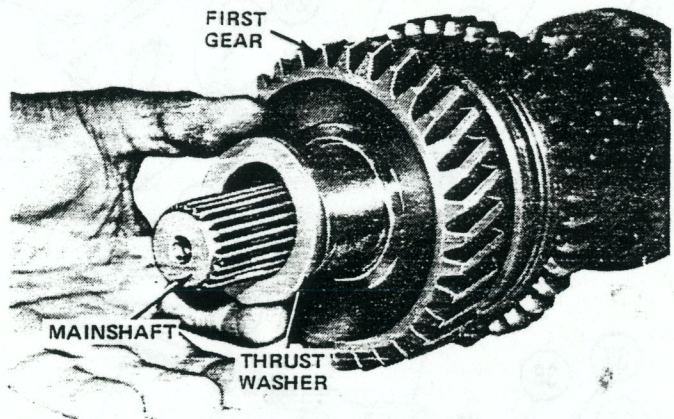

90635

Fig. 2B-37 First Gear and Thrust Washer Installation

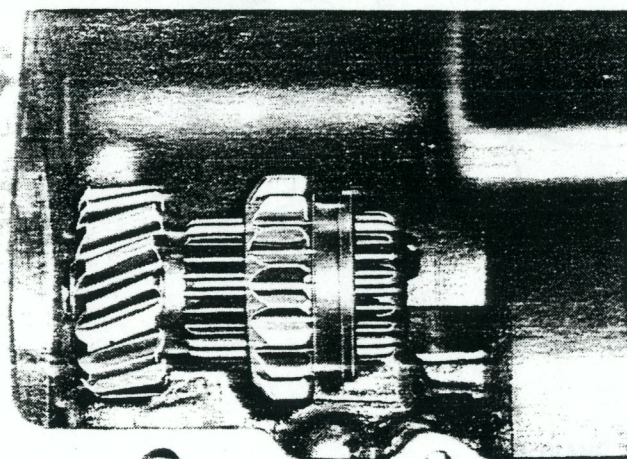

90634

Fig. 2B-35 Reverse Idler Gear Installation

(14) Install new first-second synchronizer snap ring on mainshaft (fig. 2B-33).

(15) Install first gear and blocking ring on rear of mainshaft and install first gear thrust washer (fig. 2B-37).

(16) Install new tabbed thrust washer on mainshaft. Be sure washer tab is seated in mainshaft tab bore (fig. 2B-38).

(17) Install second gear and blocking ring on mainshaft and install new second gear snap ring.

(18) Install third gear and blocking ring on mainshaft.

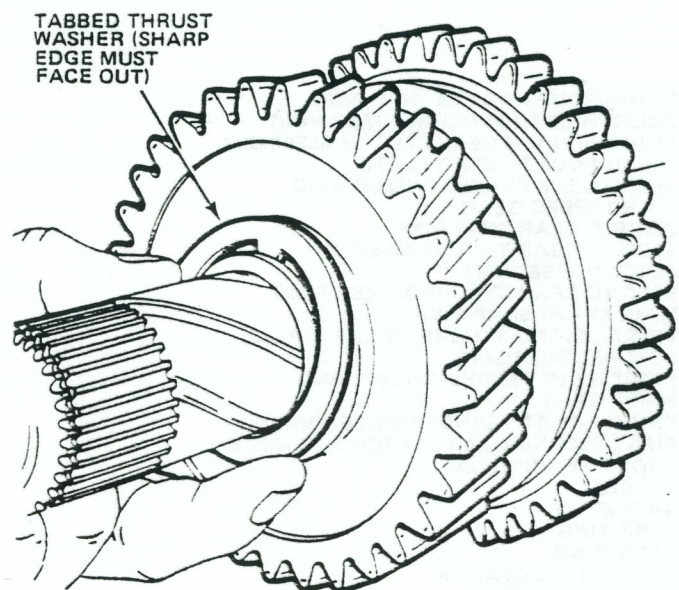

60556

Fig. 2B-38 Tabbed Thrust Washer Installation

- (19) Assemble third-fourth synchronizer (fig. 2B-33).
- Install sleeve on synchronizer hub. Align parts using reference marks.
 - Place assembled hub and sleeve flat on workbench.
 - Drop inserts into hub slots.
 - Install insert spring. Position loop-end of spring in one insert, compress spring ends and insert spring ends under lips of remaining two inserts (fig. 2B-36).
 - Turn assembly over and install remaining insert spring as described in previous step. However, position this spring so open end faces 180° opposite first spring.
- (20) Install assembled third-fourth synchronizer assembly on mainshaft.
- (21) Install new third-fourth synchronizer retaining snap ring on mainshaft and measure end play between synchronizer hub and snap ring (fig. 2B-39). End play should be 0.004 to 0.014 inches (0.10 to 0.35 mm). If end play exceeds limits, replace mainshaft thrust washers and snap rings.
- (22) Install mainshaft geartrain assembly in case. Be sure synchronizers are in neutral position so sleeves will clear top of case when assembly is installed.

CAUTION: Do not use chassis grease or a similar "heavy" grease in the clutch shaft bore. Use petroleum jelly only. Heavy grease will plug the lubrication holes in the shaft and prevent proper lubrication of the roller bearing.

(25) Coat blocking ring surface of clutch shaft with transmission lubricant and position blocking ring on shaft.

(26) Support main shaft assembly and insert clutch shaft through front bearing bore in case. Seat main shaft pilot hub in clutch shaft roller bearings and tap front bearing and clutch shaft into case using rawhide mallet.

(27) Install front bearing cap and tighten cap bolts finger tight only.

(28) Position rear bearing on mainshaft. Do not install bearing locating ring at this time. Start bearing into shaft and into case bore using Tool J-29345. Remove tool and complete bearing installation using rawhide mallet. When bearing is fully seated on shaft, install bearing retaining snap ring.

NOTE: In order to seat the rear bearing on the mainshaft, the bearing must be tapped into the case deeper than the locating snap ring would allow. For this reason, do not install the locating snap ring until after the bearing is fully seated on the shaft and the retaining snap ring is installed.

(29) Remove front bearing cap, seat front bearing fully on clutch shaft and install bearing retaining snap ring.

(30) Apply thin film of sealer to front bearing cap gasket and position gasket on case. Be sure gasket notch is aligned with oil return hole in case.

(31) Remove front bearing cap oil seal using screwdriver and install replacement oil seal using Tool J-25233 (fig. 2B-40).

(32) Install front bearing cap. Tighten cap bolts to 12 foot-pounds (16 N•m) torque.

(33) Install locating ring on rear bearing. If necessary, reseal bearing in case using rawhide mallet.

(34) Install countershaft as follows:

(a) Turn transmission case on end. Position case at edge of workbench with clutch shaft pointing downward. Be sure countershaft bore in front of case is accessible.

(b) Have helper hold case in position.

(c) Align countershaft gear bores with thrust washers and case bores and tap shaft into place. Do not let arbor tool drop onto floor as shaft is installed.

CAUTION: Do not damage the thrust washers during counter shaft installation. Be sure they are aligned with the case bores and gear bores before tapping the countershaft into place.

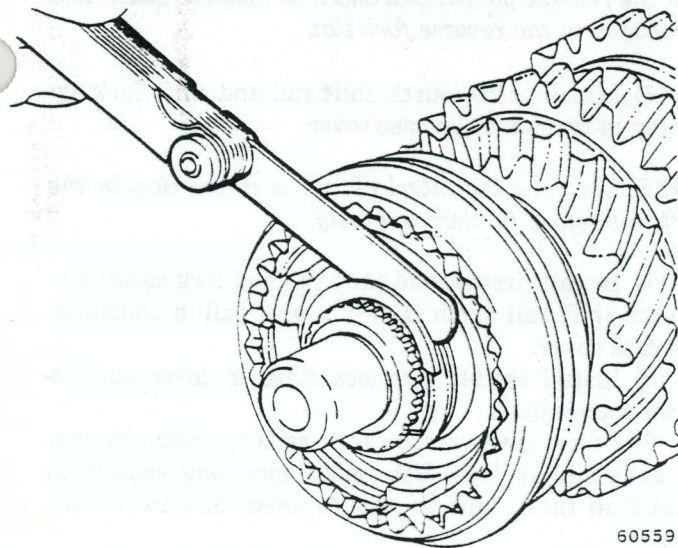

Fig. 2B-39 Checking Mainshaft Geartrain End Play

(23) Install locating snap ring on front bearing and install front bearing part-way onto clutch shaft.

NOTE: Do not install the bearing completely at this time as the shaft will not clear the countershaft gear and prevent installation.

(24) Coat bearing bore in clutch shaft and mainshaft pilot roller bearings with petroleum jelly. Install 15 roller bearings in clutch shaft bearing bore.

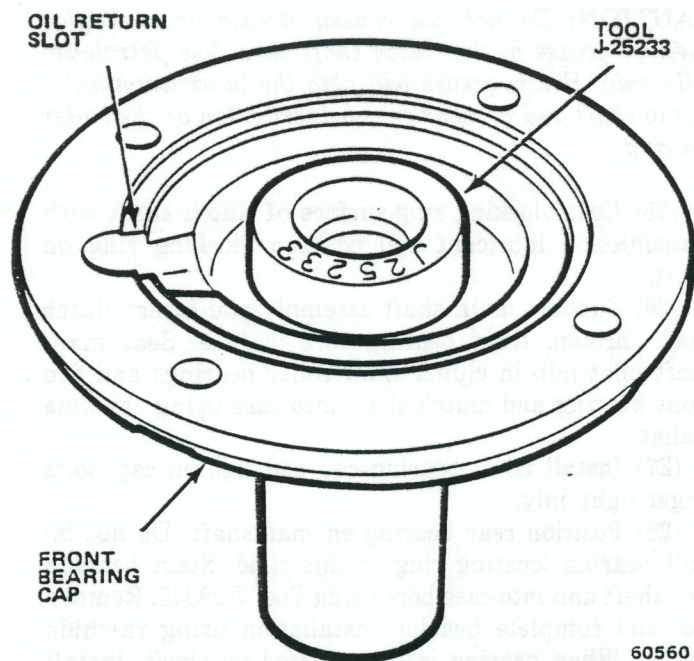

Fig. 2B-40 Front Bearing Cap Seal Installation

(35) Shift synchronizer sleeves into all gear positions and check operation. If clutch shaft and mainshaft appear to bind in Neutral position, check for blocking rings sticking on tapered portion of gears. Use screwdriver to free any sticking blocking rings.

(36) Fill transmission with 3.5 pints (1.7 liters) of SAE 85W-90 gear lubricant.

(37) Position new shift control housing gasket on case and install control housing. Tighten housing bolts to 12 foot-pounds (16 N•m) torque.

(38) Install transmission on transfer case.

SHIFT CONTROL HOUSING

Disassembly

(1) Remove shift lever cover, control housing cap, retainer and remove shift lever and spring.

(2) Position transmission case cover in vise so shift forks are facing upward. Use wood blocks to protect cover from vise jaws and do not overtighten vise.

(3) Place all shift forks in neutral position.

(4) Remove shift rail support plate attaching bolts and tabbed washers and remove support plates (fig. 2B-41).

(5) Remove first-second shift rail.

(6) Remove third-fourth shift rail, shift lug and interlock pin.

(7) Remove reverse shift rail.

(8) Remove poppet balls.

(9) Remove shifter interlock rings.

(10) Remove poppet springs.

(11) Remove fulcrum pins.

(12) Remove cover from vise.

(13) Clean all components in solvent and dry using compressed air.

(14) Inspect all components. Replace any components that are nicked, cracked, broken or excessively worn.

Assembly

(1) Clamp transmission case cover in vise using protective wood blocks and install fulcrum pins in cover.

CAUTION: To avoid damaging the cover do not overtighten the vise jaws.

(2) Lubricate shift rails and shift rail grooves in cover with petroleum jelly.

(3) Install poppet springs in transmission case cover bores.

(4) Install poppet balls (one on each spring).

(5) Position reverse gear shift rail and fork on reverse rocker arm in transmission case cover.

NOTE: Be sure the notch on the shift rail is positioned over the reverse poppet ball and that reverse rocker arm is engaged in the reverse fork slot.

(6) Install third-fourth shift rail and shift fork assembly in transmission case cover.

NOTE: Be sure the interlock pin is in position in the shift rail before further assembly.

(7) Install first-second shift rail and fork assembly. Be sure shift rail notch is over poppet ball in transmission case cover.

(8) Install shifter interlock rings in cover and between poppet balls.

(9) Press downward on shift rails to compress poppet balls and springs. Use wood block long enough to contact all three shift rails to press rails downward evenly.

(10) While holding shift rails downward, position shift rail retaining plates on housing and install plate attaching bolts and tabbed washers finger-tight.

(11) Remove wood block and tighten shift rail retaining bolts to 12 to 15 foot-pounds (16 to 19 N•m) torque. Be sure tabbed washers are in correct position before bending washer tabs.

(12) Check shift rail operation. Each rail must slide smoothly in cover groove. Be sure it is not possible to overshift into another gear position. After checking shift operation, place forks in third gear position.

(13) Install shift lever, spring, spring retainer and control housing cap (fig. 2B-41). Push cap downward and turn clockwise to install and seat.

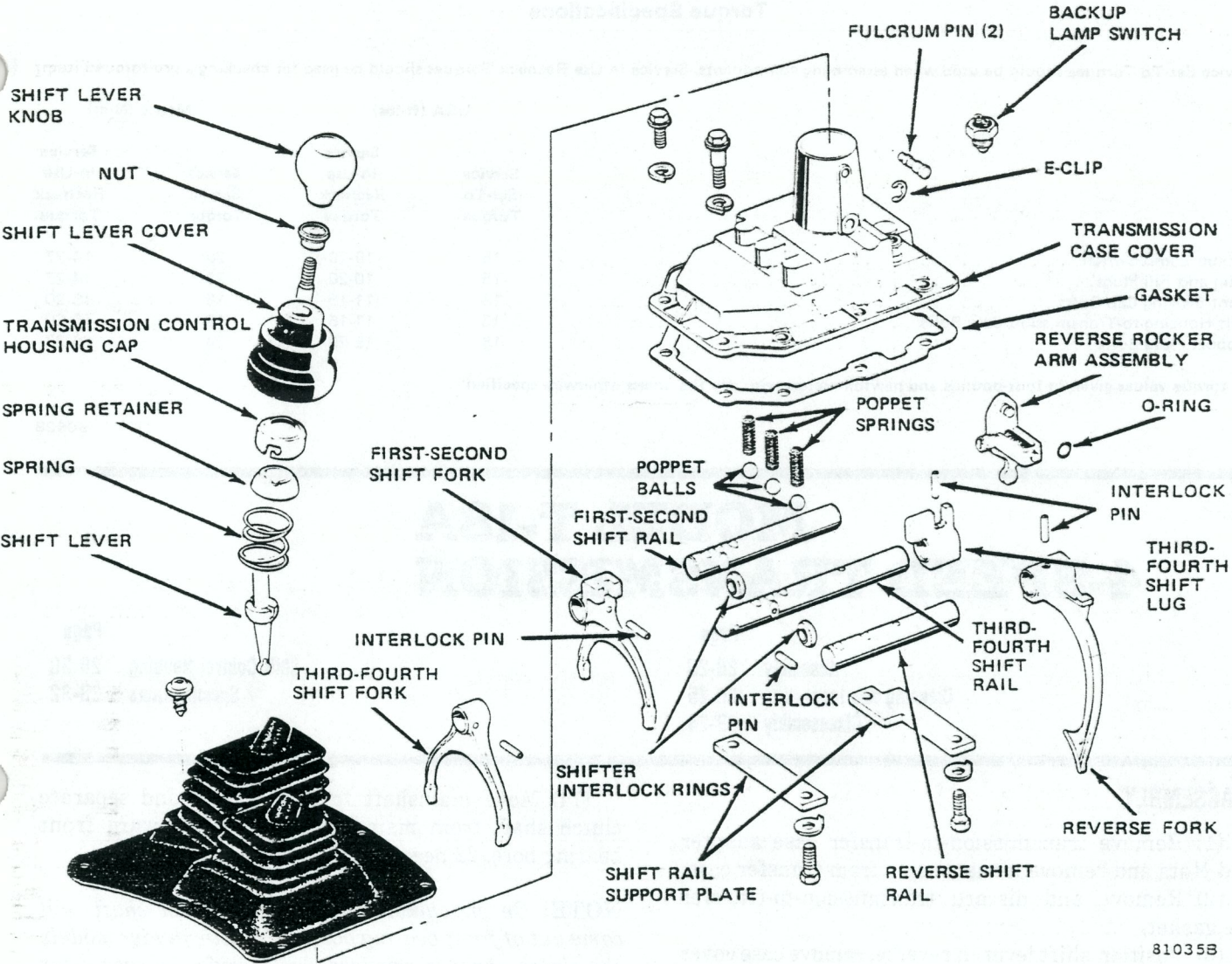

81035B

Fig. 2B-41 Shift Control Housing—T-176

SPECIFICATIONS

T-176 Lubricant Capacity and End Play Tolerances

End Play Tolerances:

Countershaft Gear to Case0004 to 0.018 inch (0.10 to 0.45 mm)
Reverse Idler Gear to Case0004 to 0.018 inch (0.10 to 0.45 mm)
Mainshaft Gear Train0004 to 0.018 inch (0.10 to 0.45 mm)
Lubricant Capacity	3.5 pints (1.7 liters)
Lubricant Type	SAE 35W-90, APJ GL5

90637

Torque Specifications

Service Set-To Torques should be used when assembling components. Service In-Use Recheck Torques should be used for checking a pre-torqued item.

	USA (ft-lbs)		Metric (N·m)	
	Service Set-To Torque	Service In-Use Recheck Torque	Service Set-To Torque	Service In-Use Recheck Torque
Backup Lamp Switch	15	10-20	20	14-27
Drain and Fill Plugs	15	10-20	20	14-27
Front Bearing Cap Bolts	13	11-15	18	15-20
Shift Housing-to-Transmission Case Bolts	13	11-15	18	15-20
Support Plate Bolts	18	15-20	24	20-27

All torque values given in foot-pounds and newton-meters with dry fits unless otherwise specified.

90638

MODEL T-18A 4-SPEED TRANSMISSION

	Page		Page
Assembly	2B-25	Shift Control Housing	2B-30
Cleaning and Inspection	2B-25	Specifications	2B-32
Disassembly	2B-24		

DISASSEMBLY

- (1) Remove transmission-to-transfer case adapter Stud Nuts and remove transmission from transfer case.
- (2) Remove and discard transmission-to-transfer case gasket.
- (3) Position shift lever in reverse, remove case cover bolts, remove shift control housing.
- (4) Punch alignment marks on the front bearing cap, remove capscrews and bearing cap.
- (5) Remove front bearing lock ring and snap ring.
- (6) Remove front bearing from clutch shaft using puller J-25152 (fig. 2B-43).
- (7) Remove front bearing retainer washer from clutch shaft.
- (8) Remove rear adapter housing retaining bolts and housing.
- (9) Remove rear bearing lock ring and snap ring.
- (10) Reinstall front bearing cap temporarily.
- (11) Remove rear bearing using Puller Set J-25152.

NOTE: If the bearing puller plates will not seat in the bearing snap ring groove, tap the end of the clutch shaft with a lead hammer to move the mainshaft rearward and expose the bearing groove fully.

- (14) Move mainshaft to rear of case and separate clutch shaft from mainshaft by pulling toward front bearing bore. 22 needle bearings will be displaced.

NOTE: On six-cylinder models the clutch shaft will come out of front bearing bore. On eight-cylinder models the clutch shaft is removed from inside the case after mainshaft assembly removal.

- (15) Remove bearing roller spacer from mainshaft pilot hub (fig. 2B-42).
- (16) Remove mainshaft assembly through top of case.
- (17) Remove clutch shaft through top of case.
- (18) Remove lock plate retaining bolt from countershaft and reverse idler gear shaft, and remove lock plate.
- (19) Tap countershaft toward rear of case using brass drift and hammer. Stop when end of shaft is approximately even with front inside edge of case bore.
- (20) Complete countershaft removal as follows:
 - (a) Make arbor tool from steel rod 1.115 inches (2.83 cm) in diameter by 9.85 inches (25.01 cm) long.
 - (b) After making tool, remove all burrs or sharp edges using file.
 - (c) Insert tool into shaft bore at front of case and drive countershaft out rear of case. Keep tool in constant contact with shaft to avoid displacing bearing rollers or washers.

- (12) Remove front bearing cap.
- (13) Rotate clutch shaft until flat area of fourth speed gear is in line with the countershaft gear.

(21) Tip case on side and remove countershaft gear and arbor tool as assembly.

(22) Remove countershaft gear thrust washers and any mainshaft pilot bearing rollers that may have fallen into case during mainshaft removal.

(23) Remove reverse idler gear shaft using brass drift through front bearing opening in case (fig. 2B-42).

(24) Remove arbor tool from countershaft gear and remove bearing rollers, washers and spacer.

(25) Remove snap rings, bearing rollers, washers and sleeve from reverse idler gear.

(26) Remove fill plug, drain plug and 22 clutch shaft needle bearings from case.

(27) Remove front bearing cap seal and rear adapter seal.

Main Shaft Gear Train Disassembly

(1) Scribe alignment marks on main shaft splines and clutch hubs for assembly reference.

(2) Remove pilot bearing spacer from front of main shaft (fig. 2B-42).

(3) Remove third-fourth synchronizer snap ring and remove third-fourth synchronizer assembly and third gear (fig. 2B-42).

(4) Remove first-second synchronizer snap ring and remove first-second synchronizer assembly (fig. 2B-42).

(5) Remove second gear snap ring and remove thrust washer and second gear.

(6) Scribe alignment marks on clutch hubs and sleeves for assembly reference.

(7) Remove insert springs and shifting plates from third-fourth clutch sleeve and remove sleeve from hub. Observe position of springs and plates for assembly reference.

(8) Place first-second synchronizer assembly on work bench and wrap cloth around clutch sleeve. Cloth is necessary to prevent losing shift plate lock balls during disassembly.

(9) Remove clutch sleeve from hub.

(10) Remove cloth from sleeve and remove lock balls, insert spring and shift plates from hub.

CLEANING AND INSPECTION

Clean and inspect the transmission case and all components thoroughly. If any transmission gear requires replacement, also replace the gear with which it meshes. Use new gaskets, oil seals and snap rings during assembly.

Inspect the transmission case for cracks and worn or scored bearing bosses. Examine the ball bearings for cracked races, excessive wear, looseness, and for tight fit in the case bores. Inspect all gear teeth for cracks, chips, or spots where gear hardening has worn through. Main shaft gears must not bind on the shaft and should not exhibit excessive play. Inspect the synchronizer blocking

rings for cracks, excessive wear, or pitting in the tapered area of the ring. If thrust washer condition is doubtful, replace them.

Check all bearing rollers for flat spots, pitting, cracks or other damage. Replace rollers as required. Inspect the countershaft and reverse idler shafts for pitting, wear, scores, nicks, cracks and flat spots. Small nicks or scores can be reduced using crocus cloth or a fine-tooth file. Replace shafts if severely worn or damaged. Inspect the mainshaft and synchronizer hubs and sleeves for damaged or worn splines, cracks, worn mainshaft pilot hub and damaged mainshaft threads. Replace parts as required. Check reverse shifting arm and pivot pin for wear or other damage, and replace if necessary.

ASSEMBLY

NOTE: *Prelubricate all components with petroleum jelly during assembly.*

Reverse Idler Gear

- (1) Install snap ring in one end of reverse idler gear.
- (2) Install thrust washer in gear bore against snap ring.
- (3) Insert sleeve in gear bore.
- (4) Install 37 roller bearings in one end of gear and install bearing spacer (fig. 2B-42).
- (5) Install remaining 37 roller bearings in opposite end of gear and install remaining thrust washer and snap ring.

Countershaft Gear Assembly

- (1) Install bearing spacer sleeve in gear and insert arbor tool into gear and through sleeve.
- (2) Slide one bearing spacer onto arbor tool and seat spacer against sleeve.
- (3) Insert 22 roller bearings into gear bore and seat bearings against spacer just installed.
- (4) Slide second bearing spacer onto arbor tool and seat spacer against bearings.
- (5) Install 22 more roller bearings in gear bore and seat bearings against second spacer.
- (6) Install third bearing spacer on arbor tool and seat spacer against bearings.
- (7) Repeat spacer/bearing installation procedure at opposite end of gear.

First-Second Synchronizer Assembly

NOTE: *The third-fourth clutch hub is used to help assemble the first-second synchronizer assembly.*

- (1) Place third-fourth clutch hub on workbench.
- (2) Install insert spring in first-second clutch hub spring groove.

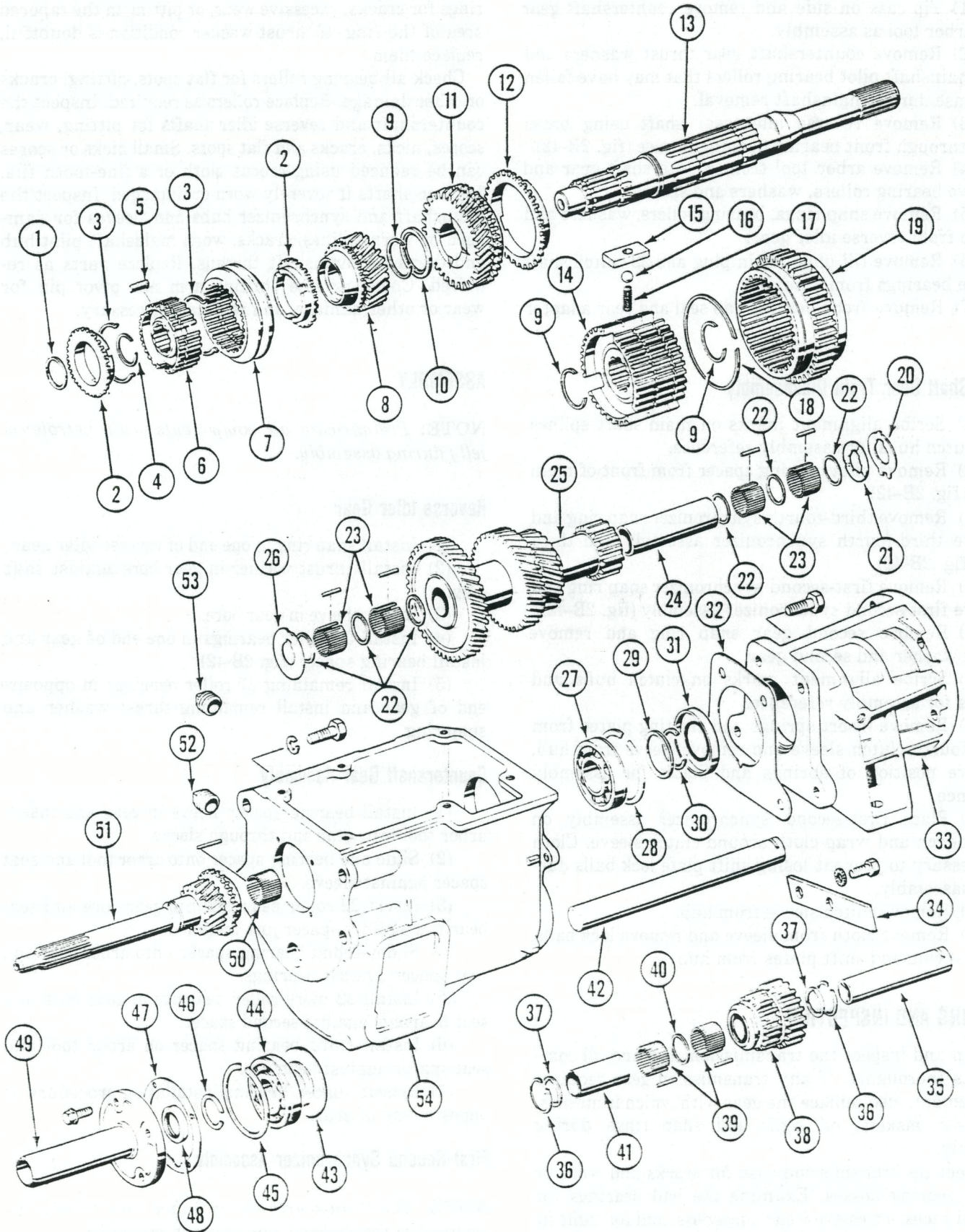

Fig. 2B-42 Model T-18A 4-Speed Transmission

1. MAINSHAFT PILOT BEARING ROLLER SPACER
2. THIRD-FOURTH BLOCKING RING
3. THIRD-FOURTH RETAINING RING
4. THIRD-FOURTH SYNCHRONIZER SNAP RING
5. THIRD-FOURTH SHIFTING PLATE (3)
6. THIRD-FOURTH CLUTCH HUB
7. THIRD-FOURTH CLUTCH SLEEVE
8. THIRD GEAR
9. MAINSHAFT SNAP RING
10. SECOND GEAR THRUST WASHER
11. SECOND GEAR
12. SECOND GEAR BLOCKING RING
13. MAINSHAFT
14. FIRST-SECOND CLUTCH HUB
15. FIRST-SECOND SHIFTING PLATE (3)
16. POPPET BALL
17. POPPET SPRING
18. FIRST-SECOND INSERT RING
19. FIRST-SECOND CLUTCH SLEEVE
20. COUNTERSHAFT GEAR THRUST WASHER (STEEL) (REAR)
21. COUNTER SHAFT GEAR THRUST WASHER (STEEL BACKED BRONZE) (REAR)
22. COUNTERSHAFT GEAR BEARING WASHER
23. COUNTERSHAFT GEAR BEARING ROLLERS (88)
24. COUNTERSHAFT GEAR BEARING SPACER
25. COUNTERSHAFT GEAR
26. COUNTERSHAFT GEAR THRUST WASHER (FRONT)
27. REAR BEARING

28. REAR BEARING LOCATING SNAP RING
29. REAR BEARING SPACER RING
30. REAR BEARING SNAP RING
31. ADAPTER PLATE SEAL
32. ADAPTER PLATE TO TRANSMISSION GASKET
33. ADAPTER TO TRANSMISSION
34. COUNTERSHAFT-REVERSE IDLER SHAFT LOCKPLATE
35. REVERSE IDLER GEAR SHAFT
36. REVERSE IDLER GEAR SNAP RING
37. REVERSE IDLER GEAR THRUST WASHER
38. REVERSE IDLER GEAR
39. REVERSE IDLER GEAR BEARING ROLLERS (74)
40. REVERSE IDLER GEAR BEARING WASHER
41. REVERSE IDLER SHAFT SLEEVE
42. COUNTERSHAFT
43. FRONT BEARING RETAINER WASHER
44. FRONT BEARING
45. FRONT BEARING LOCATING SNAP RING
46. FRONT BEARING LOCK RING
47. FRONT BEARING CAP GASKET
48. FRONT BEARING CUP SEAL
49. FRONT BEARING CAP
50. MAINSHAFT PILOT BEARING ROLLERS (22)
51. CLUTCH SHAFT
52. DRAIN PLUG
53. FILLER PLUG
54. TRANSMISSION CASE

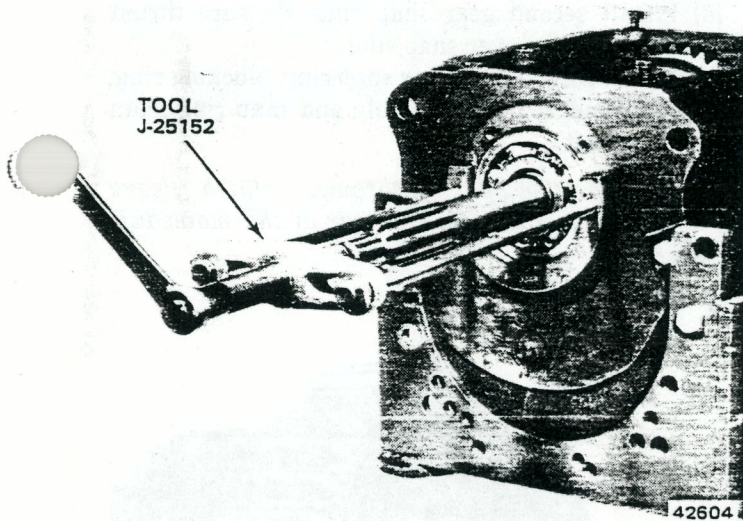

Fig. 2B-43 Front Bearing Removal

(d) Maintain pressure on ball and spring and slide shifting plate downward in hub slot until ball is held in position by clutch sleeve.

(6) Install remaining shift plates, poppet springs and lock balls as described in previous step.

(7) Complete synchronizer assembly by pressing down on hub and pulling up on sleeve.

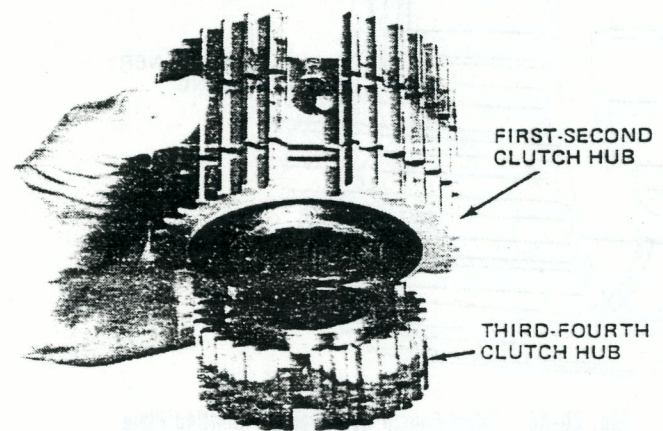

Fig. 2B-44 Supporting First-Second Clutch Hub

(3) Position first-second clutch hub on top of third-fourth hub so lock ball holes in first-second hub are in uppermost position (fig. 2B-44).

(4) Align scribe marks on first-second hub and sleeve and install sleeve on hub (fig. 2B-45). Allow sleeve to bottom against work bench.

(5) Install each shifting plate, poppet spring and lock ball assembly one at a time as follows (fig. 2B-45):

- (a) Install shifting plate in hub slot.
- (b) Insert poppet spring through plate.
- (c) Position lock ball on poppet spring, and

compress ball and spring (fig. 2B-45).

NOTE: To ease lock ball installation use 7/32-inch socket and 1/4-inch drive extension to press lock ball into place.

Third-Fourth Synchronizer Assembly

(1) Align and assemble third-fourth clutch hub and sleeve using reference marks made at disassembly.

(2) Insert shifting plates in hub slots.

(3) Install insert springs so one end of each spring is hooked into same shifting plate (fig. 2B-46).

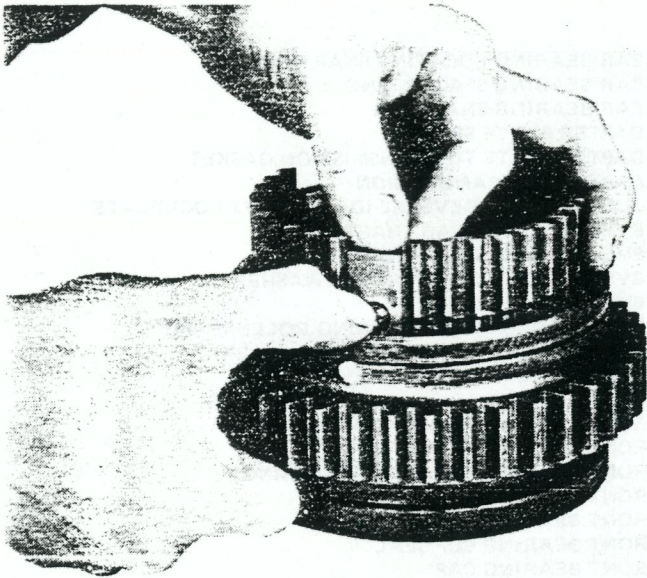

42606

Fig. 2B-45 Assembling First-Second Synchronizer

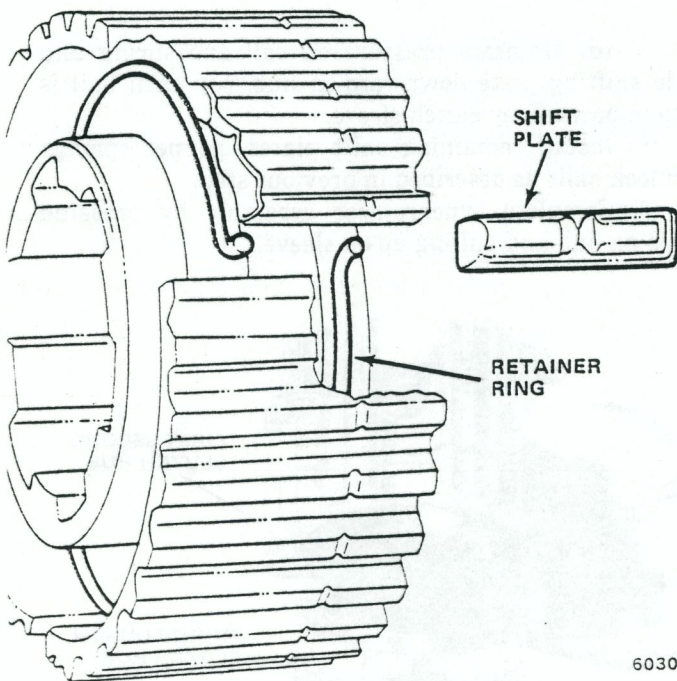

60308

Fig. 2B-46 Third-Fourth Synchronizer Shifting Plate and Retaining Ring Installation

Clutch Shaft Assembly

- (1) Lubricate mainshaft bearing rollers and clutch shaft bore with generous quantity of petroleum jelly.
- (2) Install 22 bearing rollers in clutch shaft bore. Use additional petroleum jelly to help retain rollers in bore if necessary.
- (3) Coat blocking ring with petroleum jelly and install ring on clutch shaft.

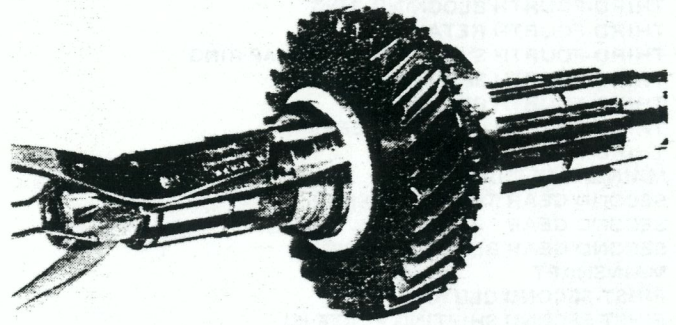

42608

Fig. 2B-47 Second Gear and Thrust Washer Installation

Mainshaft and Geartrain Assembly

- (1) Install second gear from front of mainshaft (fig. 2B-47).
- (2) Install second gear thrust washer so step bore in washer faces front end of mainshaft.
- (3) Install second gear snap ring. Be sure thrust washer step bore fits over snap ring.
- (4) Install second gear rear snap ring, blocking ring, first-second synchronizer assembly and snap ring from rear of mainshaft.

NOTE: The first-second synchronizer clutch sleeve shift fork groove must face the rear of the mainshaft (fig. 2B-48).

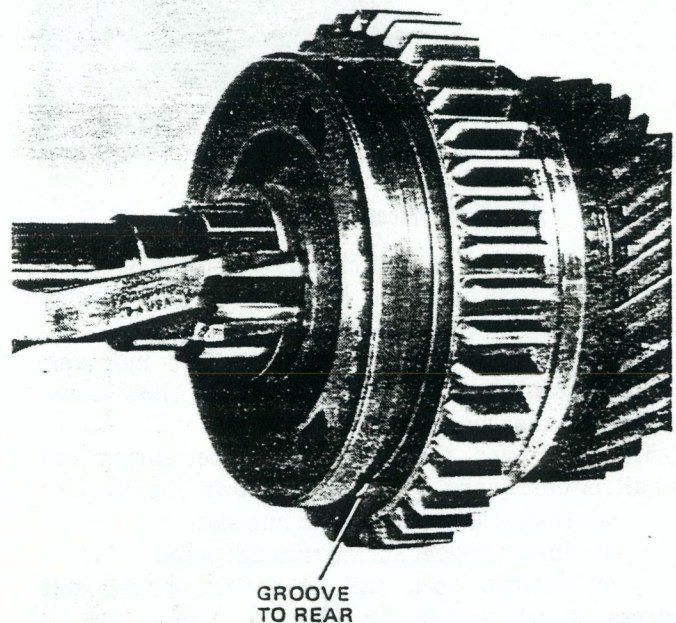

42609

Fig. 2B-48 First-Second Synchronizer Installation

(5) Install third gear on mainshaft and install blocking ring on gear.

(6) Install third-fourth synchronizer assembly on mainshaft (fig. 2B-42).

NOTE: *The third-fourth synchronizer must be installed with the chamfered side of the hub facing the front of the mainshaft (fig. 2B-49).*

(7) Install third-fourth synchronizer retaining ring (fig. 2B-42).

(8) Install mainshaft bearing roller spacer on shaft pilot hub (fig. 2B-42).

Transmission Case Assembly

(1) Coat countershaft thrust washers with petroleum jelly and install washers in case. Index tab on large, bronze-faced washer in locating recess in front of case. Index notch in smaller, steel washer with locating lug at rear of case.

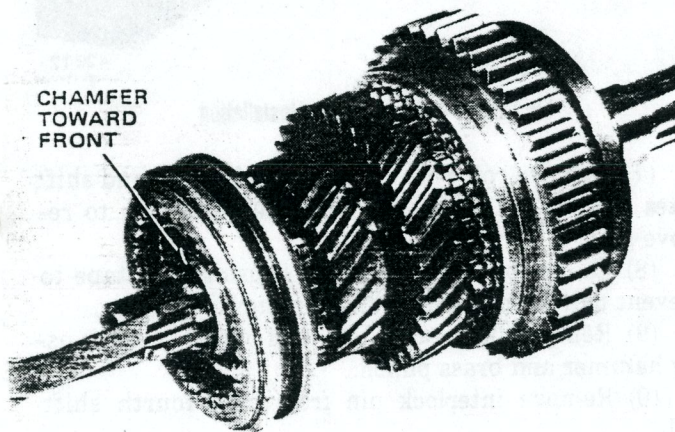

42610

Fig. 2B-49 Third-Fourth Synchronizer Installation

(2) Install countershaft gear assembly.

(3) Install remaining countershaft thrust washer between rear of countershaft gear and smaller, steel thrust washer.

(4) Install countershaft from rear of case but do not install shaft completely. Stop installation when shaft just starts into case front bore.

CAUTION: *When installing the countershaft, keep the shaft and arbor tool in constant contact to avoid displacing any bearing rollers or bearing washers.*

(5) Install reverse idler gear. Larger gear end must face rear of case.

(6) Install reverse idler gear shaft from rear of case. Tap shaft forward until lock plate slot in shaft is aligned with lock plate slot in countershaft.

(7) Install lock plate in countershaft and reverse idler gear shaft slots.

(8) Tap ends of countershaft and reverse idler gear shafts alternately until shafts are fully installed.

(9) Insert assembled clutch shaft and fourth gear blocking ring in case front bearing bore. Insert shaft from case interior, not from front or outside of case.

(10) Install mainshaft and gear train assembly.

(11) Install mainshaft pilot bearing roller spacer on mainshaft pilot hub if not installed previously.

(12) Insert mainshaft pilot hub in clutch shaft bore. Be sure bearing rollers in clutch shaft are not displaced and that fourth gear blocking ring notches are aligned with shifting plates.

(13) Install front bearing cap temporarily to support clutch shaft.

(14) Install retaining snap ring on rear bearing and drive bearing onto mainshaft and into case rear bore. Seat snap ring against case.

CAUTION: *During rear bearing installation avoid wedging each blocking ring on its mating tapered surface.*

(15) Install replacement oil seal in transfer case adapter plate.

CAUTION: *The adapter plate oil seal must be installed correctly to prevent lubricant flow from the transfer case into the transmission. When correctly positioned, the seal lip will face the transfer case (fig. 2B-50).*

(16) Coat lip of adapter plate oil seal with petroleum jelly.

(17) Position replacement transmission-to-adapter gasket on transmission and install adapter plate. Apply nonhardening sealer to adapter plate attaching bolts and install bolts.

(18) Remove front bearing cap and install front bearing retaining washer on clutch shaft with dished side of washer facing mainshaft.

(19) Slide front bearing onto clutch shaft and tap bearing into case bore using section of pipe or driver sleeve (fig. 2B-51). Be sure to seat bearing against clutch shaft gear shoulder and front bearing retainer washer.

CAUTION: *During front bearing installation avoid wedging each blocking ring on its mating tapered surface.*

(20) Install thickest front bearing lock ring in clutch shaft ring groove.

NOTE: *The front bearing lock rings are available in four thicknesses.*

(21) Pull clutch shaft and front bearing forward just far enough to expose locating snap ring groove in bearing. Install locating snap ring and push clutch shaft rearward until locating snap ring seats against case.

(22) Position front bearing cap gasket on front bearing cap. Coat threads of bearing cap attaching bolts with

nonhardening sealer. Align oil return holes in cap, gasket and case, and install attaching bolts. Tighten bolts to 15 foot-pounds (20 N•m) torque.

(23) Check all synchronizer blocking rings for free movement. If blocking rings were wedged onto the tapered hubs of the clutch shaft, third and second speed gears during bearing installation, pry them free using screwdriver.

(24) Move synchronizer sleeves to Neutral position.

(25) Install fill and drain plugs and pour two pints of gear lubricant over all gears while rotating mainshaft.

(26) Coat shift control housing with RTV silicone sealer and install housing on case. Be sure shift forks engage synchronizer sleeves and that reverse shift arm engages flat on reverse shift rail.

(27) Coat shift lever housing attaching bolts with nonhardening sealer and install bolts. Tighten bolts to 12 foot-pounds (16 N•m) torque.

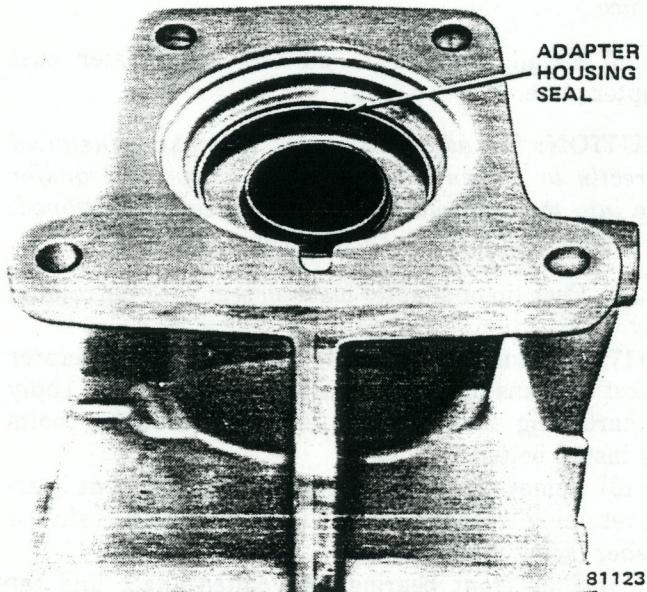

Fig. 2B-50 Adapter Plate Oil Seal Position

(28) Shift gears through all positions to check operation.

(29) Assemble transfer case and transmission and tighten attaching bolts to 30 foot-pounds (41 N•m) torque.

SHIFT CONTROL HOUSING

Disassembly

(1) Unthread shift lever cap and remove cap, gasket if equipped, spring seat, spring and shift lever as assembly (fig. 2B-52).

(2) Remove shift lever locating pins from housing (fig. 2B-52).

(3) Mount housing in vise with shift forks facing upward.

(4) Remove backup lamp switch.

(5) Remove shift rail bore plugs using hammer and punch.

(6) Move shift rails to Neutral position.

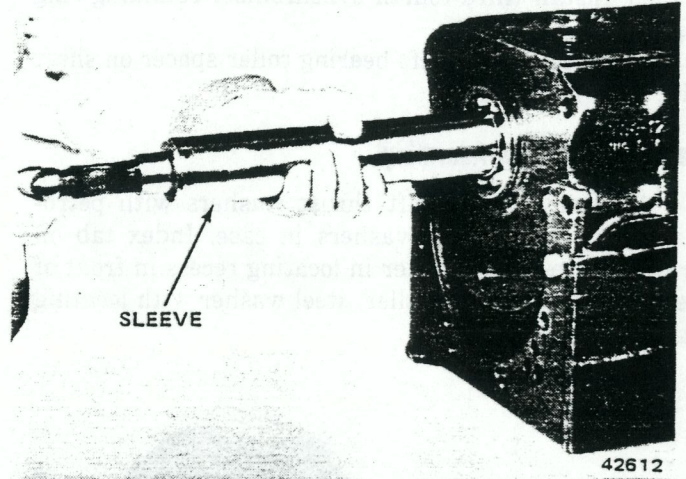

Fig. 2B-51 Front Bearing Installation

(7) Remove roll pins attaching shift forks and shift gates to shift rails. Use hammer and pin punch to remove pins.

(8) Cover poppet ball holes in housing with tape to prevent ball or spring loss during removal.

(9) Remove shift rails. Tap rails out of housing using hammer and brass punch.

(10) Remove interlock pin from third-fourth shift rail.

(11) Remove shift forks and shift gates. Be sure to mark or note position of forks and gates for assembly reference before removal.

(12) Remove poppet balls and springs from housing.

(13) Remove interlock plungers from housing.

(14) Remove retaining clip from reverse shift gate and remove spring and plunger from gate.

(15) Inspect housing breather. Remove breather if damaged or restricted in any way.

Assembly

(1) Install replacement breather in housing if removed.

(2) Install spring and plunger in reverse shift gate. Compress plunger and install plunger retaining clip.

(3) Insert reverse shift rail into housing. Install reverse shift fork on rail and slide rail up to but not into shift rail poppet bore.

(4) Install poppet spring and ball in reverse shift rail poppet bore. Compress ball and spring using punch and slide rail through bore.

(5) Install reverse shift gate on opposite end of shift rail and slide rail into housing until poppet ball engages rail notch. Install shift gate so plunger pin boss faces rear of housing (fig. 2B-53).

(6) Align and install roll pins that fasten reverse shift fork and shift gate to shift rail.

(7) Install interlock plungers in pockets located between housing shift rail poppet bores.

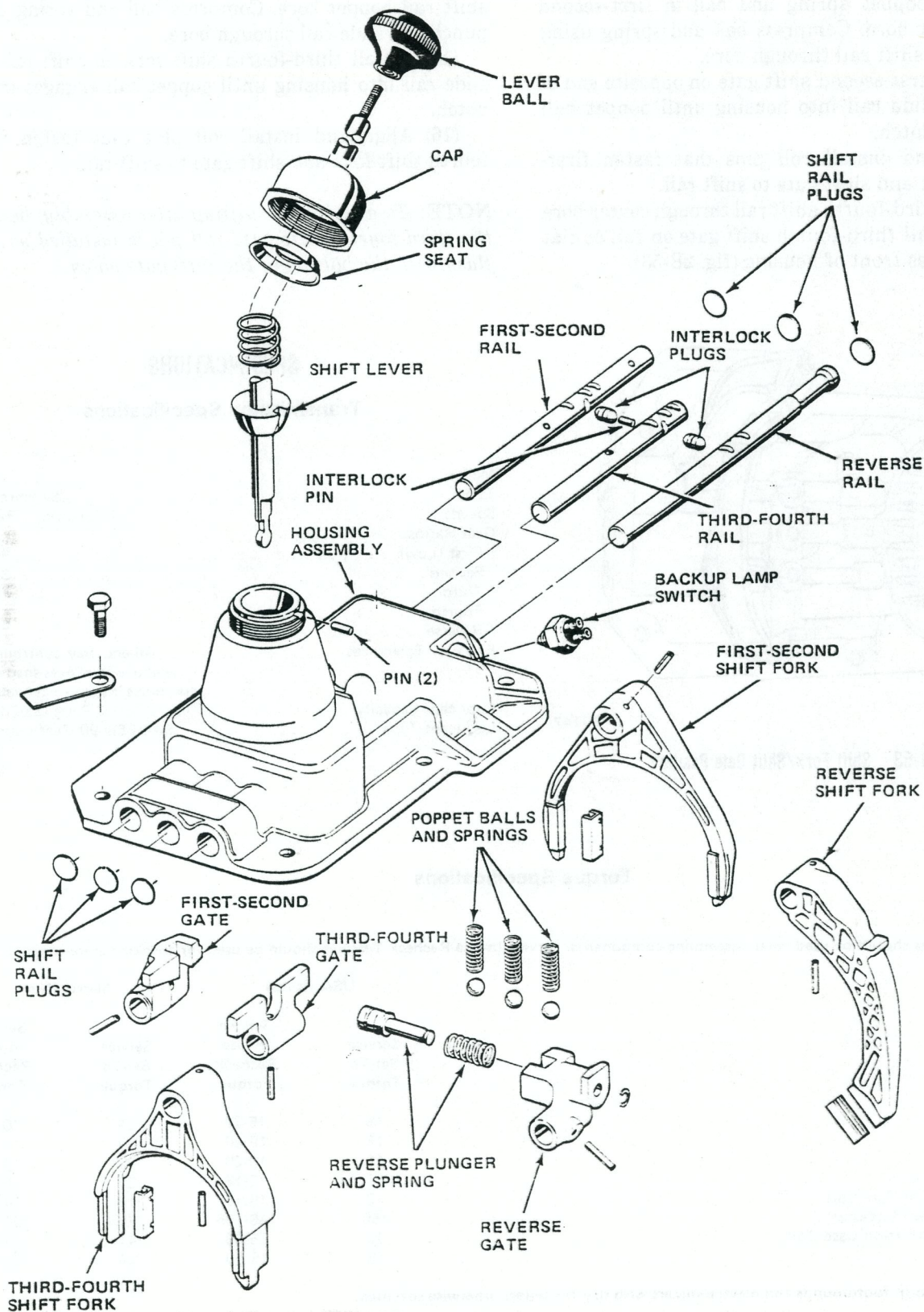

Fig. 2B-52 Shift Control Housing—Transmission Model T-18A

(8) Insert first-second shift rail into housing. Install first-second shift fork on rail so fork offset faces rear of housing (fig. 2B-53). Slide shift rail up to but not into shift rail poppet bore.

(9) Install poppet spring and ball in first-second shift rail poppet bore. Compress ball and spring using punch and slide shift rail through bore.

(10) Install first-second shift gate on opposite end of shift rail and slide rail into housing until poppet ball engages in rail notch.

(11) Align and install roll pins that fasten first-second shift fork and shift gate to shift rail.

(12) Insert third-fourth shift rail through center bore in housing. Install third-fourth shift gate on rail so flat tang on gate faces front of housing (fig. 2B-53).

(13) Coat interlock pin with petroleum jelly (to hold it in place) and install pin in third-fourth shift rail pin bore.

(14) Install poppet spring and ball in third-fourth shift rail poppet bore. Compress ball and spring using punch and slide rail through bore.

(15) Install third-fourth shift fork on shift rail and slide rail into housing until poppet ball engages in rail notch.

(16) Align and install roll pins that fasten third-fourth shift fork and shift gate to shift rail.

NOTE: To avoid hard shifting after assembly, be sure the third-fourth shift gate roll pin is installed so it is flush with the bottom of the shift gate notch.

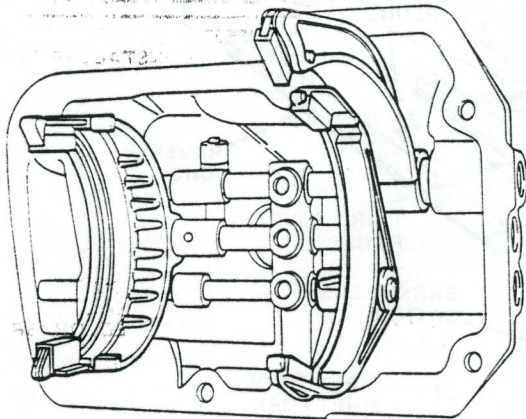

90147

Fig. 2B-53 Shift Fork/Shift Gate Position

SPECIFICATIONS

Transmission Specifications

Model	T18A
Type	Synchromesh
Speeds	4 Forward, 1 Reverse
Gear Ratios:	
First (Low)	6.32:1
Second	3.09:1
Third	1.69:1
Fourth	1.00:1
Reverse	7.44:1
End Play Tolerances	All end play controlled by selective thickness snap rings.
	Use thickest snap rings available.
Lubricant Capacity	6-1/2 Pints (3.07 liters)
Lubricant Type	SAE 85W-90 Gear Lubricant

80122

Torque Specifications

Service Set-To Torques should be used when assembling components. Service In-Use Recheck Torques should be used for checking a pre-torqued item.

	USA (ft-lbs)		Metric (N-m)	
	Service Set-To Torque	Service In-Use Recheck Torque	Service Set-To Torque	Service In-Use Recheck Torque
Backup Lamp Switch	18	15-20	24	20-27
Drain Plug	15	10-20	20	14-27
Fill Plug	15	10-20	20	14-27
Front Bearing Cap Bolt	15	12-18	20	16-24
Shift Control Housing-to-Case Bolt	12	10-15	16	14-20
Transfer Case Drive Gear Locknut	150	145-155	203	197-210
Transfer Case-to-Transmission Case Bolt	30	25-35	41	34-47
TCS Switch	18	15-20	24	20-27

All torque values given in foot-pounds and newton-meters with dry fits unless otherwise specified.

Refer to the Standard Torque Specifications and Capscrew Marking chart in Chapter A for torque values not listed above.

80123

Tools

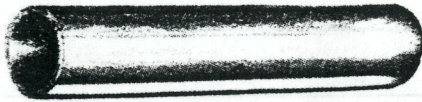

J-25234
BEARING INSTALLER TOOL (SR-4)

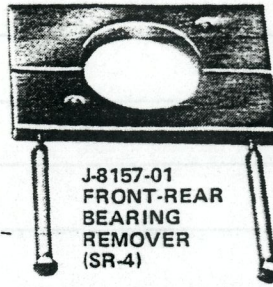

J-8157-01
FRONT-REAR
BEARING
REMOVER
(SR-4)



J-26625
FRONT BEARING CAP
SEAL INSTALLER (SR-4)

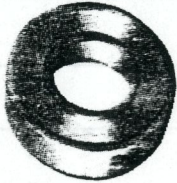

J-25233
FRONT BEARING CAP
SEAL INSTALLER (T-176)



J-26624
COUNTERSHAFT
ARBOR TOOL (SR-4)

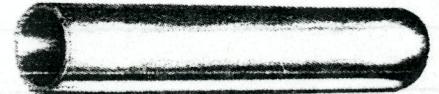

J-22697
BEARING INSTALLER (SR-4)

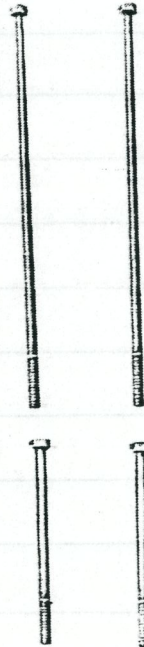
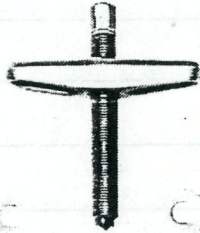
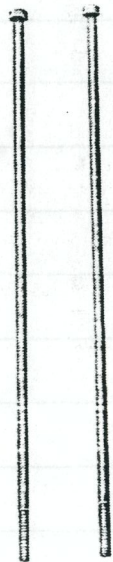

J-25152
BEARING PULLER SET



J-26628-1
OIL SEAL
INSTALLER (SR-4)



J-26628-2
OIL SEAL
PROTECTOR (SR-4)

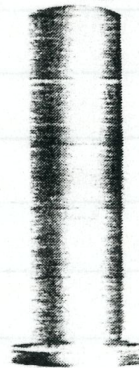

J-29343
REVERSE IDLER SHAFT
ARBOR TOOL (T-176)

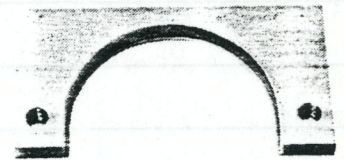

J-29344
FRONT BEARING
PULLER (T-176)



J-29342
COUNTERSHAFT
ARBOR TOOL (T-176)



J-29345
BEARING STARTER (T-176)

NOTES

Horizontal lines for notes, including faint bleed-through text from the reverse side of the page.