

# AUTOMATIC TRANSMISSION

# 2C

## SECTION INDEX

|                               | Page  |                                     | Page  |
|-------------------------------|-------|-------------------------------------|-------|
| Diagnosis and Test Procedures | 2C-12 | In-Vehicle Service and Adjustment   | 2C-26 |
| General Information           | 2C-1  | Out-of-Vehicle Service and Overhaul | 2C-33 |
| Hydraulic Flow Charts         | 2C-73 | Tools                               | 2C-70 |

## GENERAL INFORMATION

|                           | Page  |                         | Page  |
|---------------------------|-------|-------------------------|-------|
| Fluid Capacity            | 2C-4  | Periodic Maintenance    | 2C-11 |
| Gearshift Lever Positions | 2C-10 | Power Flow              | 2C-6  |
| General                   | 2C-1  | Torque Converter        | 2C-1  |
| Hydraulic Control System  | 2C-9  | Towing                  | 2C-11 |
| Identification            | 2C-6  | Transmission Components | 2C-5  |

### GENERAL

The automatic transmissions used in Jeep vehicles are fully automatic, three speed, hydraulically operated units with a compound planetary gear system. A three element torque converter is used for all applications. A manually operated column gearshift linkage is used to select the desired gear range. Transmission shift points are controlled by an externally mounted throttle linkage. The transmission case and converter housing consists of a one-piece aluminum casting. An aluminum adapter housing is used to connect the transmission to the various transfer case models.

### Transmission Applications

Three automatic transmission models are used. They are models 904, 999 and 727 (figs. 2C-1 and 2C-2). Model 904 is used in CJ-7 models (only) equipped with a four-cylinder engine. This transmission has a wide ratio gear set with a low gear ratio of 2.74:1. Model 999 transmissions are used in CJ-7 models with either a six- or eight-cylinder engine. Model 727 is used in Cherokee, Wagoneer and Truck models with six- or eight-cylinder engines. An automatic transmission is not available in CJ-5 models equipped with the 2.5 liter four-cylinder engine.

### Torque Converter Applications

Two different type torque converters are used for Jeep vehicles. CJ-5 models with a four-cylinder engine use a conventional torque converter. CJ-7, Cherokee, Wagoneer and Truck models with six- or eight-cylinder engine use a lockup torque converter. A high stall lockup torque converter is used with the model 727 transmission for six-cylinder engine applications. A low stall lockup torque converter is used with the model 727 transmission for eight-cylinder applications. The two converters are not interchangeable.

### Conventional Torque Converter

The conventional torque converter is a three element unit consisting of a front cover, impeller, turbine, stator, and stator overrunning clutch. The impeller is connected to the engine crankshaft through the front cover which is welded to the impeller. The turbine is splined to the transmission input shaft, and the stator is splined to the reaction shaft.

### Lockup Torque Converter

The lockup torque converter is similar to a conventional unit in that a turbine, impeller, and stator are employed. However, unlike a conventional unit, the lockup converter has an internal mechanism for locking

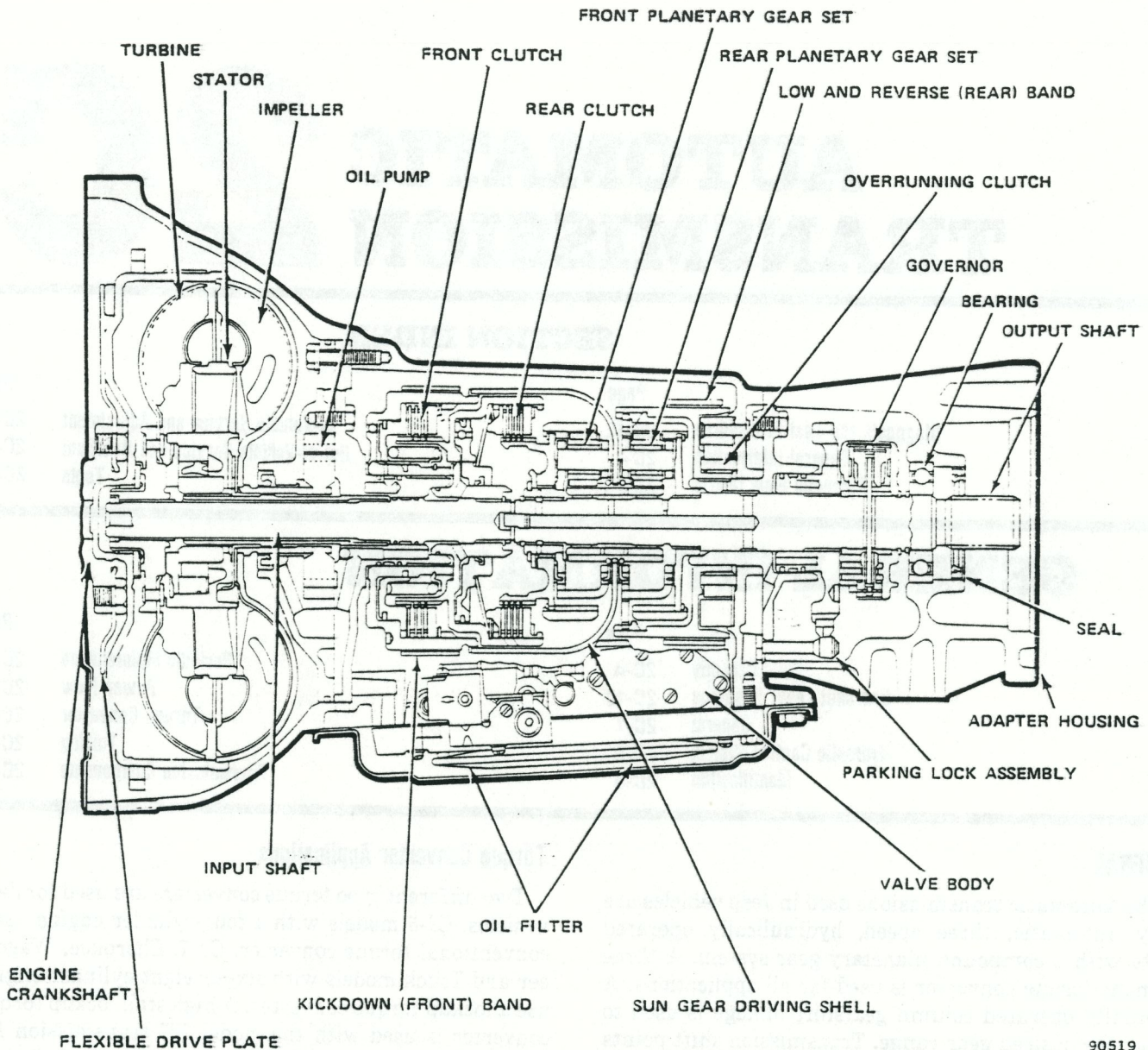

Fig. 2C-1 Automatic Transmission Model 904

90519

improved fuel economy and reduced fluid operating temperatures.

The lockup system consists of a lockup mechanism within the converter, a lockup module attached to the valve body, and a switch valve in the valve body. The switch valve is actually the converter control valve which has been modified for lockup system use.

The converter internal lockup mechanism consists of a sliding clutch piston, torsion springs, and clutch friction material. The friction material is attached to the front cover, the clutch piston is mounted in the turbine, and the torsion springs are located on the forward side of the turbine. The torsion springs dampen out engine firing impulses and absorb shock loads that occur during lockup.

When the transmission shifts into direct drive and vehicle speed reaches approximately 38 mph (61 k/ph),

transmission fluid is channeled through the input shaft and into the area between the clutch piston and turbine. At this point, fluid pressure extends the piston pressing it against the front cover friction material locking the turbine to the impeller (fig. 2C-4). When vehicle speed drops below 40 mph (64 k/ph) or the transmission shifts out of direct drive, fluid pressure is released, the clutch piston retracts, and the converter operates in a conventional manner again.

### Torque Converter Service

The torque converter is a welded assembly and is not serviceable. If diagnosis indicates a malfunction has occurred or if the converter becomes contaminated with foreign material, replace the converter as an assembly only. Do not attempt to repair or flush the unit. In

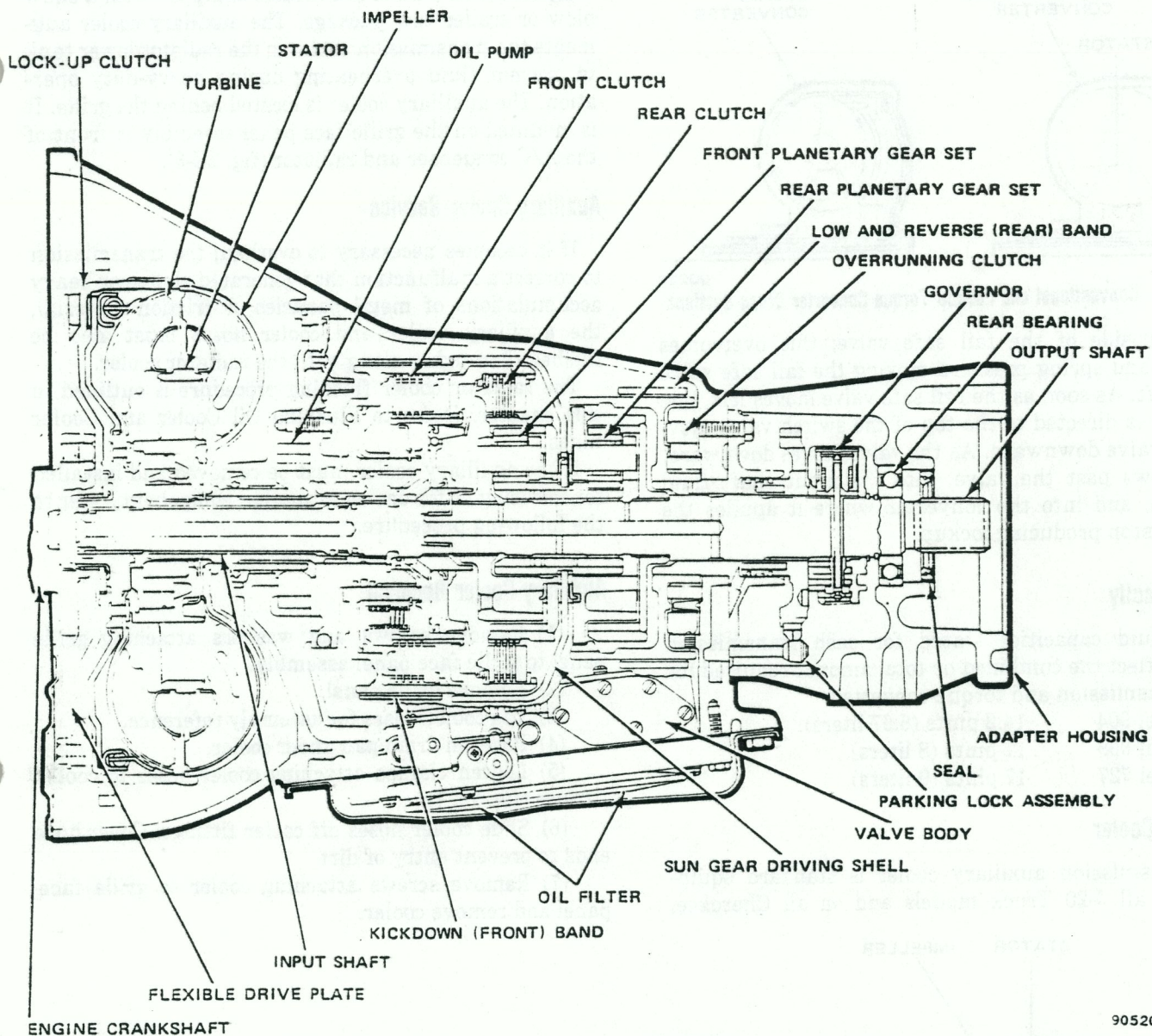

90520

Fig. 2C-2 Automatic Transmission Models 999/727

addition, never attempt to interchange lockup and conventional converters. The transmission input shaft and valve body required for lockup operation are markedly different.

### Lockup Converter Control System

The system controls consist of a lockup module attached to the valve body and a switch valve located within the valve body. The switch valve is actually the converter control valve which has been modified for lockup system use. The lockup module contains a fail safe valve and a lockup valve and is used for lockup converter applications only.

The lockup valve reacts to governor pressure and directs the switch valve to move in or out of lockup position (fig. 2C-5). The switch valve controls fluid flow to

the converter clutch piston. The fail safe valve is a protective device in that it permits lockup only in direct drive and only if front clutch apply pressure (as received from the 2-3 shift valve) is sufficient.

The lockup control system is operative in direct drive only and system components are calibrated to produce lockup at a vehicle speed and governor pressure of approximately 40 mph (64 k/ph) and 38 psi (263 kPa). In operation, governor pressure reaches lockup point and overcomes lockup valve spring tension which moves the valve to the left (fig. 2C-5). This allows line pressure from the rear clutch circuit to enter the fail safe valve. As the lockup valve moves left, governor pressure against the 2-3 governor plug also moves the 2-3 shift valve into direct drive position. At this point, line pressure is channeled from the 2-3 shift to the shuttle valve, is further directed into and past the lockup valve, and to

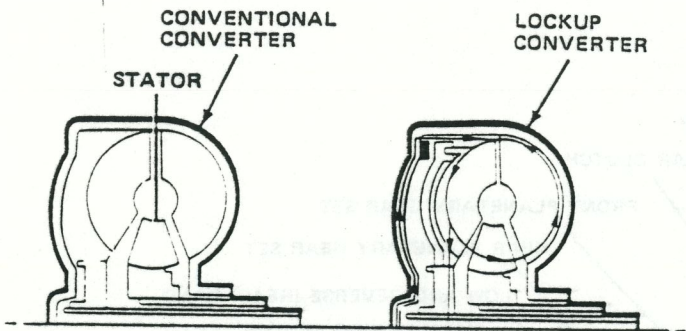

90220

Fig. 2C-3 Conventional and Lockup Torque Converter Cross Sections

the right-side of the fail safe valve; this overcomes throttle and spring pressure moving the fail safe valve to the left. As soon as the fail safe valve moves left, line pressure is directed to the top of the switch valve moving the valve downward. As the valve moves downward, fluid flows past the valve, into the input shaft fluid channels, and into the converter where it applies the clutch piston producing lockup.

**Fluid Capacity**

The fluid capacities stated for each transmission model reflect the combined or total amount required for both transmission and torque converter.

- Model 904 14.2 pints (6.67 liters)
- Model 999 17 pints (8 liters)
- Model 727 17 pints (9 liters)

**Auxiliary Cooler**

A transmission auxiliary cooler is standard equipment on all J-20 Truck models and on all Cherokee,

Wagoneer and J-10 Truck models equipped with a snow plow or trailer tow package. The auxiliary cooler augments the transmission cooler in the radiator lower tank to prevent fluid overheating during heavy-duty operation. The auxiliary cooler is located behind the grille. It is mounted on the grille face panel assembly in front of the A/C condenser and radiator (fig. 2C-6).

**Auxiliary Cooler Service**

If it becomes necessary to overhaul the transmission to correct a malfunction that generated sludge or heavy accumulations of metal particles or friction material, the auxiliary cooler and cooler hoses must also be flushed thoroughly along with the radiator cooler.

The radiator cooler flushing procedure is outlined in this chapter. Refer to Flushing Oil Cooler and Cooler Lines.

If the auxiliary cooler must be removed and installed for servicing or for access to another component, refer to the following procedure.

**Auxiliary Cooler Removal**

- (1) Remove screws and washers attaching grille panel to grille face panel assembly.
- (2) Remove grille panel.
- (3) Tag cooler hoses for assembly reference.
- (4) Position drain pan under cooler.
- (5) Loosen clamps attaching cooler hoses to cooler fittings (fig. 2C-7).
- (6) Slide cooler hoses off cooler fittings. Cover hose ends to prevent entry of dirt.
- (7) Remove screws attaching cooler to grille face panel and remove cooler.

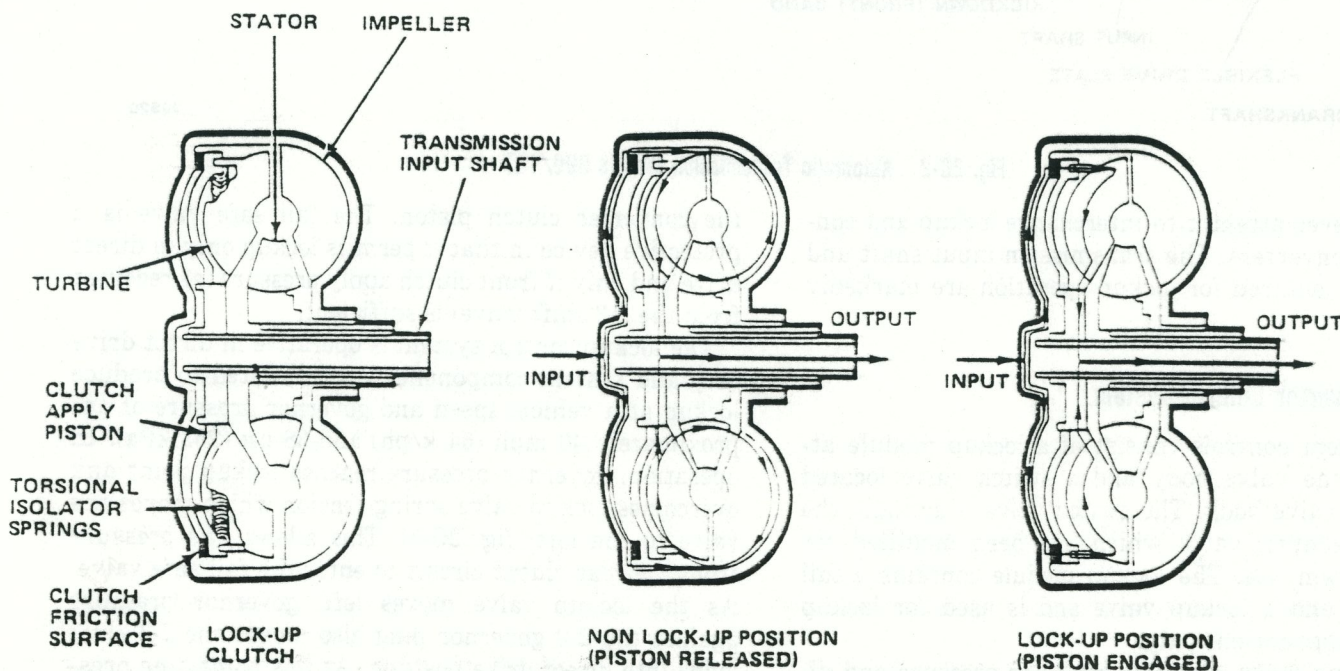

Fig. 2C-4 Lockup Torque Converter Operation

90221

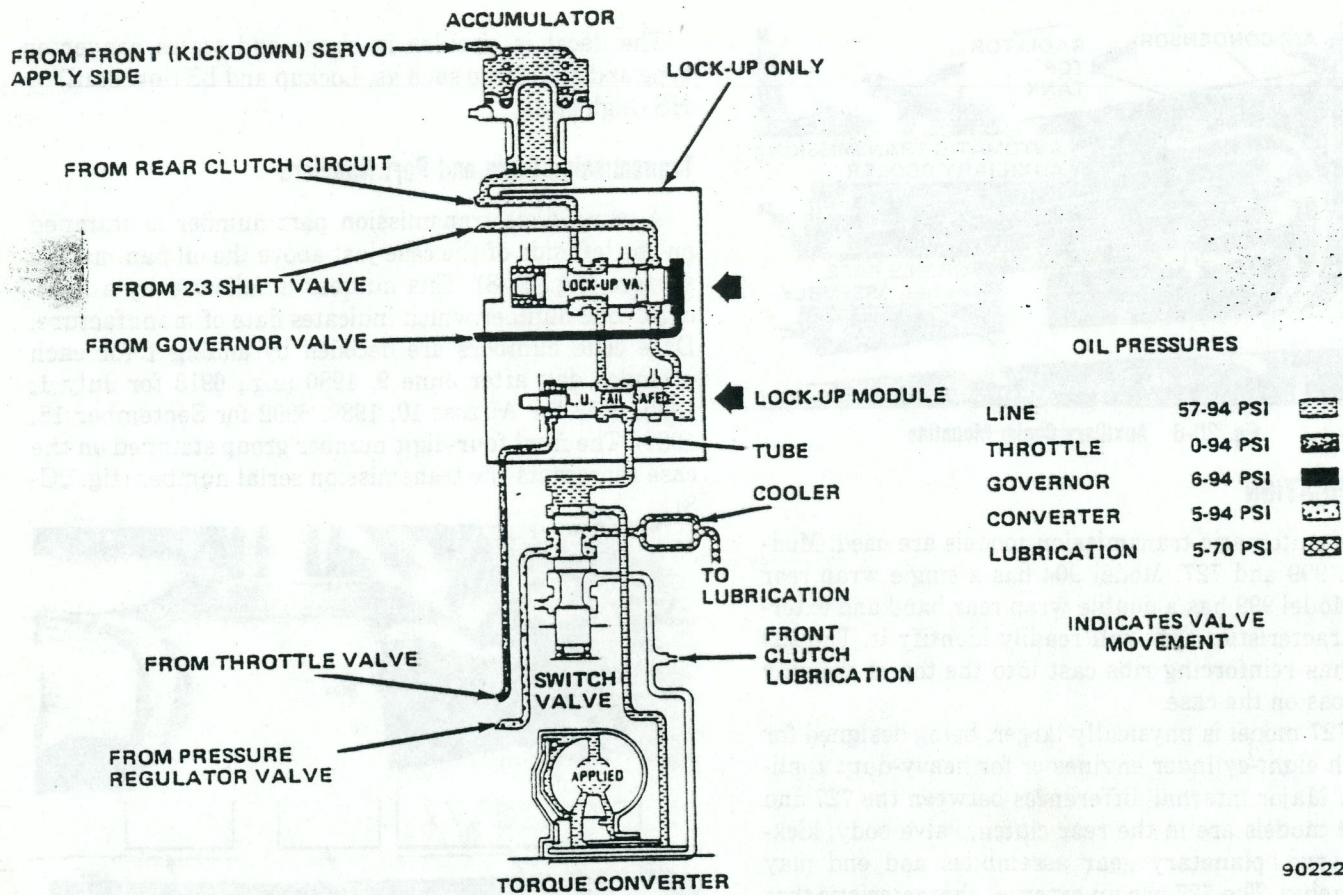

Fig. 2C-5 Lockup Torque Converter Control System

**Auxiliary Cooler Installation**

- (1) Position cooler on grille face panel and install cooler attaching screws.
- (2) Remove protective covering from ends of cooler hoses and install hoses on cooler fittings.
- (3) Tighten cooler hose clamps securely.
- (4) Position grille panel on grille face panel and install grille panel attaching screws.
- (5) Check and correct transmission fluid level.

- 1st Gear 2.74:1
- 2nd Gear 1.55:1
- 3rd Gear 1.00:1
- Reverse 2.20:1

**TRANSMISSION COMPONENTS**

**Clutch-Band-Gear System**

Transmission models 999 and 727 each have two multiple disc clutches, two bands and actuating servos, an overrunning clutch and two planetary gear sets, all of which combine to provide one reverse and three forward gear ranges. The planetary gear sets are connected by a common sun gear. The sun gear is interconnected to the multiple disc clutches through the driving shell which is splined to the sun gear and front clutch retainer.

The model 904 transmission used on four-cylinder CJ models has a wide ratio planetary gear set. Ratios are:

**Hydraulic System**

The hydraulic system consists of a single oil pump, a valve body containing the pressure regulating shift control, and lockup control valves, a governor valve assembly, two band actuating servos as an accumulator.

**Fluid Cooling and Filtration**

The transmission fluid is cooled by circulating the fluid through an external cooler built into the radiator lower tank.

Transmission fluid is filtered by a Dacron element filter attached to the valve body. The filter is a serviceable component and can be replaced whenever diagnosis or service requirements indicate the need.

**Transmission Venting**

The transmission is vented through a passage drilled into the upper portion of the oil pump housing.

90222

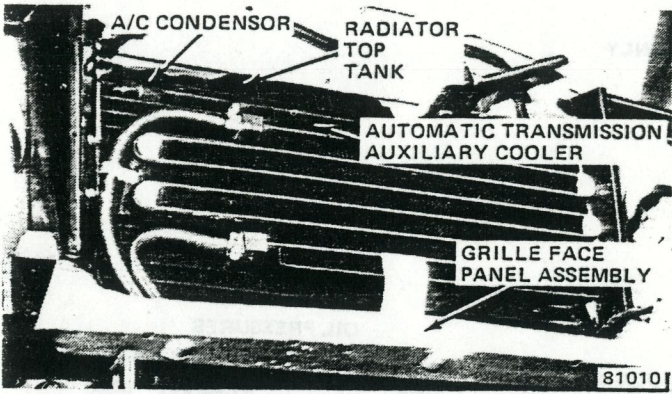

Fig. 2C-6 Auxiliary Cooler Mounting

**IDENTIFICATION**

Three automatic transmission models are used: Models 904, 999 and 727. Model 904 has a single wrap rear band. Model 999 has a double wrap rear band and external characteristics that will readily identify it. The 999 model has reinforcing ribs cast into the top of the rear servo boss on the case.

The 727 model is physically larger, being designed for use with eight-cylinder engines or for heavy-duty applications. Major internal differences between the 727 and 904/999 models are in the rear clutch, valve body, kick-down servo, planetary gear assemblies and end play adjustments. The 727 has an external characteristic that distinguishes it from the 999 models; the slope of the converter housing is much more gradual.

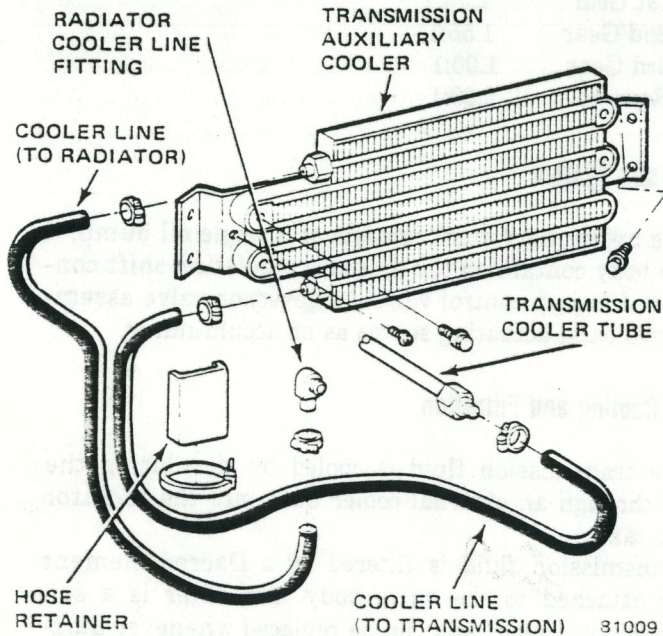

Fig. 2C-7 Auxiliary Cooler Assembly

**Lockup Torque Converter Identification**

Because the lockup mechanism is completely enclosed within the converter and not visible, lockup converters have an identifying decal attached to the front cover.

The decal is circular in shape and states converter type and stall ratio such as, Lockup and LS (low stall) or HS (high stall).

**Transmission Code and Part Numbers**

A seven-digit transmission part number is stamped on the left side of the case just above the oil pan mating surface (fig. 2C-8). This number is followed by a four-digit code number which indicates date of manufacture. Date code numbers are decoded by adding 1 for each calendar day after June 9, 1980 (e.g., 6913 for July 1, 1980, 6953 for August 10, 1980, 6992 for September 18, 1980). The final four-digit number group stamped on the case represents the transmission serial number (fig. 2C-8).

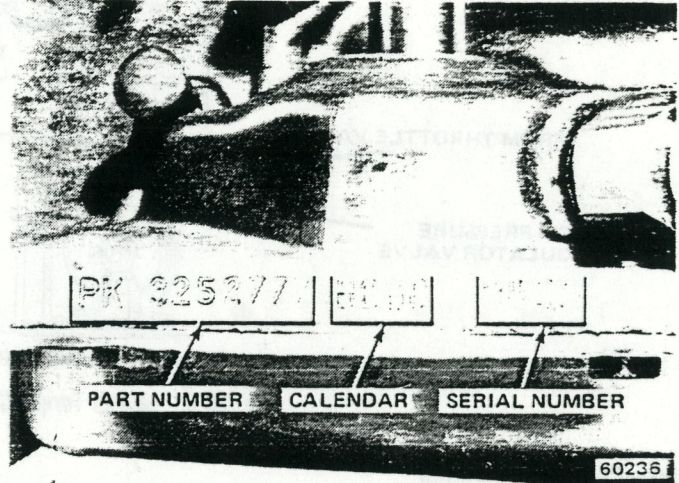

Fig. 2C-8 Transmission Code and Part Numbers

**POWER FLOW**

The torque converter front cover and impeller, which is welded to the cover (fig. 2C-9), are connected to the engine crankshaft by a drive plate and to the transmission input shaft by the converter overrunning clutch. In operation, power flow is as follows: Engine torque is transmitted to the torque converter front cover through the drive plate which connects the crankshaft and converter. The converter multiplies engine torque and transmits this torque directly to the input shaft and subsequently to the multiple disc clutches in the transmission.

The clutches then transfer engine torque through the two planetary gear sets and to the transmission output shaft. However, the actual torque flow path through the planetary gear sets is dependent on the clutch/band combination in effect at that point in transmission operation. Refer to the Clutch and Band Application Chart for details.

The torque transmitted through the planetary gear sets is applied to the transmission output shaft. Torque is then transferred through the transfer case and to the axles by the propeller shafts to complete the torque transfer cycle.

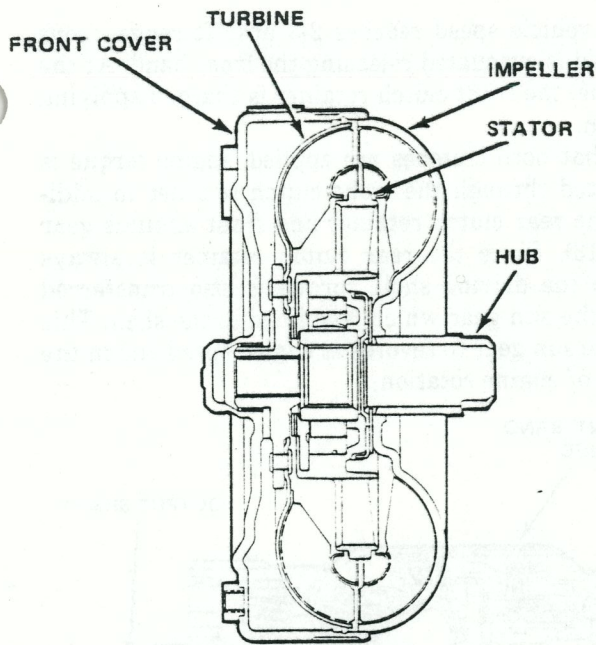

90521

Fig. 2C-9 Three Element Torque Converter

## Torque Flow

### Neutral-Park Position

In Neutral and Park positions, none of the transmission clutches or bands are applied (fig. 2C-10).

With the engine running, torque is transmitted to the front clutch hub/rear clutch retainer by the input shaft. However, since clutch—band application has not occurred, torque flow stops at the rear clutch retainer. The rear clutch plates which are splined to the rear clutch retainer, rotate with the retainer at engine speed and direction of rotation. The rear clutch discs, which are splined to the front annulus gear, remain stationary.

### Drive-First Gear

In Drive-first gear, the rear clutch is applied and the overrunning clutch holds the rear planetary gear carrier.

When shifted into Drive, the valve body directs fluid at operating pressure into the rear clutch retainer. Fluid pressure locks the rear clutch lined discs against the steel plates applying the clutch. Since the lined discs are splined to the front annulus gear, the rear clutch retainer and annulus gear are locked together (figs. 2C-10 and 2C-11). Engine torque is now transmitted through the rear clutch retainer to the front annulus gear, turning the gear at engine speed and in the direction of engine rotation. The front planetary gears, which are meshed with the front annulus gear, also rotate at engine speed and in the direction of engine rotation.

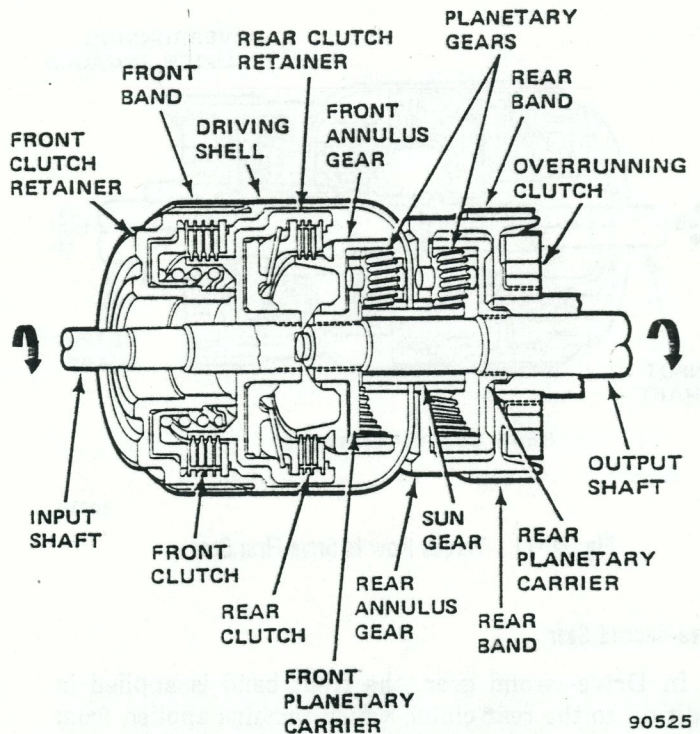

90525

Fig. 2C-10 Clutch, Band and Gear System

Both front and rear planetary gears are in mesh with the sun gear (fig. 2C-11). The sun gear has a reverse helix which causes it to revolve opposite engine rotation when turned by the front planetary gears. However, as a result of this helix, the sun gear causes the rear planetary gears to revolve in the same direction as engine rotation. At this point, torque flow is through the rear clutch and front annulus gear, into the front planetary gears and to the rear planetary gears through the counter-rotating sun gear (fig. 2C-11).

The rear annulus gear is splined to the output shaft. The rear planetary gear carrier is locked to the low/reverse drum which in turn is splined to the overrunning clutch inner race. The overrunning clutch permits carrier/drum rotation in the direction of engine rotation only; the clutch locks up if turned opposite to the direction of engine rotation.

With the rear annulus gear stationary, the action of the revolving rear planetary gears on the rear annulus gear causes the rear planetary carrier and low/reverse drum to rotate opposite engine direction. However, because the low/reverse drum is splined to the overrunning clutch, the clutch locks up preventing both drum and carrier from turning in a direction opposite to engine rotation.

Because the rear planetary carrier and low/reverse drum are held stationary by the overrunning clutch, torque is then transferred to the output shaft through the rear annulus gear which is splined to the shaft.

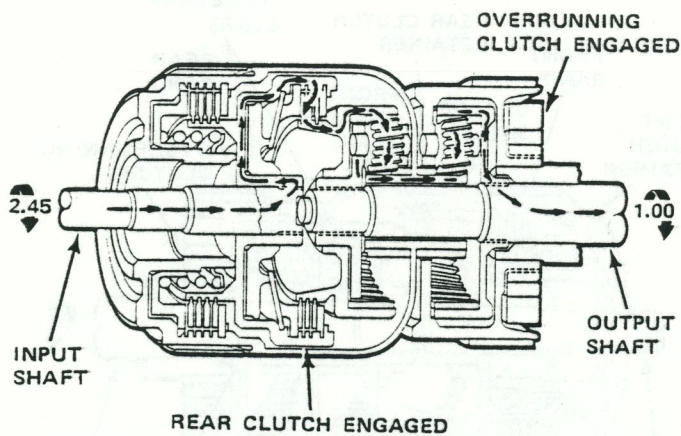

Fig. 2C-11 Torque Flow in Drive-First Gear

80753

### Drive-Second Gear

In Drive-second gear, the front band is applied in addition to the rear clutch which remains applied from Drive-first gear. The overrunning clutch is not employed in this gear and free wheels.

In response to increasing speed and pressure signals from the governor and throttle linkage, the transmission upshifts to second gear. The front servo is charged with fluid at operating pressure to apply the front band and complete the 1-2 upshift.

When the front band is applied, it holds the front clutch retainer preventing the retainer from turning. Because the retainer is locked to the driving shell, the shell and sun gear which is splined to the driving shell are also held stationary (fig. 2C-12).

Since the rear clutch is still applied, engine torque continues to flow through the rear clutch retainer to the front annulus gear turning the gear at engine speed and direction of rotation. However, because the sun gear is now stationary, front annulus gear rotation causes the front planetary gears to revolve in engine direction of rotation. This action causes the front planetary carrier to also rotate in engine direction but at a reduced speed.

Engine torque is then transferred directly to the output shaft through the front planetary carrier which is splined to the shaft (fig. 2C-12). Note that torque flow occurs through the front planetary gears only in Drive-second gear. The rear planetary gears are idling and the low/reverse drum is freewheeling with the overrunning clutch. Although the rear annulus gear revolves with the output shaft, it does so only because it is splined to the shaft.

### Drive-Third Gear

In Drive-third gear, the front clutch is applied in addition to the rear clutch which remains applied from Drive-second gear.

When vehicle speed reaches 2-3 upshift range, front servo fluid is evacuated releasing the front band. At the same time, the front clutch retainer is charged applying the clutch.

Now that both clutches are applied, engine torque is transmitted through the front clutch retainer in addition to the rear clutch retainer and front annulus gear (fig. 2C-13). Since the rear clutch retainer is always locked to the driving shell, torque is also transferred through the sun gear which is splined to the shell. This causes the sun gear to revolve at engine speed and in the direction of engine rotation.

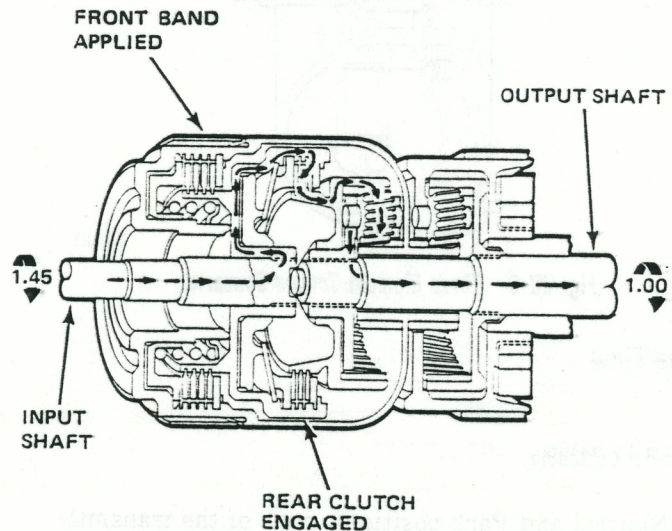

Fig. 2C-12 Torque Flow in Drive-Second Gear

80754

Because torque is still transmitted through the rear clutch retainer, front annulus gear and front planetary gear carrier, the front planetary gears transmit torque to the output shaft through the front planetary carrier which is splined to the shaft. The rear planetary gears are locked to the sun gear and the rear annulus gear and low/reverse drum rotate with the output shaft but do not transmit torque.

The front and rear planetary gears are not rotating in Drive-third gear. The only rotation present is the input from the engine and the output shaft. All other connected parts rotate as one common unit.

### Manual First Gear 1 Position

Torque flow in manual first gear is the same as in Drive-first gear except an additional element is employed. Along with the rear clutch, the rear band is also applied to provide engine braking action. The transmission will not upshift in manual first gear 1 position.

Torque flow is from the input shaft to the rear clutch retainer and front annulus gear (fig. 2C-14). The annulus gear revolves at engine speed and in the direction of engine rotation causing the front planetary gears to also rotate at engine speed and in the direction of engine rotation.



Reverse

In Reverse, the front clutch and rear band are applied. Engine torque input flows from the front clutch retainer to the driving shell which is locked to the retainer at all times (fig. 2C-15). Since the driving shell is also splined to the sun gear, it consequently turns the sun gear in engine rotation direction. Sun gear rotation then causes the planet pinions to rotate opposite engine direction.

The rear planetary gear carrier is held stationary by the rear band, as a result, torque is transmitted directly to the output shaft through the rear annulus gear which is splined to the shaft (fig. 2C-15).

In reverse, the front planetary gears are in an idling condition and all torque flows through the rear planetary gears.

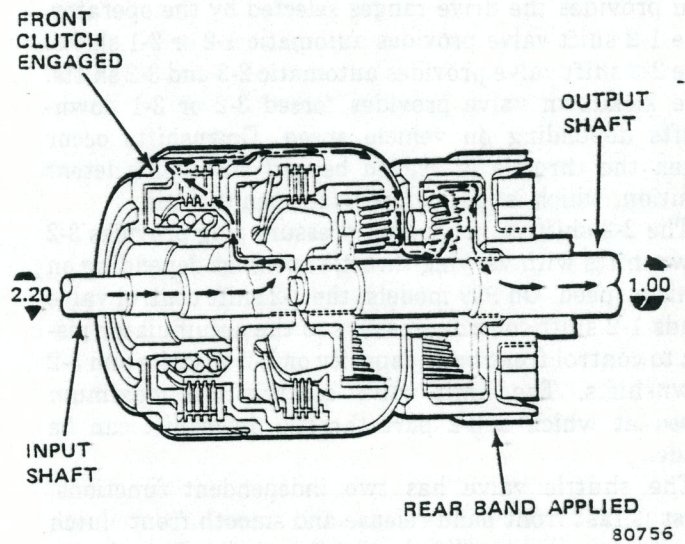

Fig. 2C-15 Torque Flow in Reverse

HYDRAULIC CONTROL SYSTEM

The hydraulic control system provides fully automatic operation of the transmission. The system performs five basic functions, which are:

- Pressure Supply
- Pressure Regulation
- Flow Control
- Clutch and Band Application
- Lubrication

Pressure Supply System

The single oil pump develops fluid pressure for operation and lubrication. The pump is driven by the engine through the torque converter.

Pressure Regulating System

The pressure regulator valve maintains transmission line pressure, however, the amount of line pressure developed is controlled by governor pressure which is dependent on the degree of throttle opening. The converter

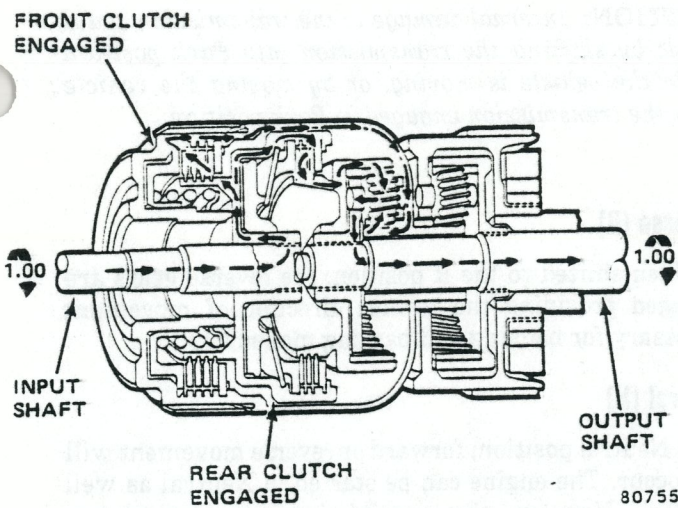

Fig. 2C-13 Torque Flow in Drive-Third Gear

The front planetary carrier, which is splined to the output shaft, is held stationary momentarily. This condition causes the front planetary gears to turn the sun gear and driving shell opposite engine rotation. Sun gear rotation then causes the rear planetary gears to rotate in engine direction. Since the rear planetary carrier is locked to the low/reverse drum, the rear band and overrunning clutch prevent the drum and carrier from rotating opposite engine direction. Rear planetary gear action causes the rear annulus gear to rotate in engine direction. Torque is transferred directly to the output shaft by the annulus gear which is splined to the shaft.

Manual Second Gear 2 Position

Torque flow and transmission elements employed in manual second gear are the same as described for drive-second gear. However, in this position, a 2-3 upshift does not occur. The transmission will perform a 1-2 upshift only. Refer to Drive-Second Gear and figure 2C-12 for a description of torque flow.

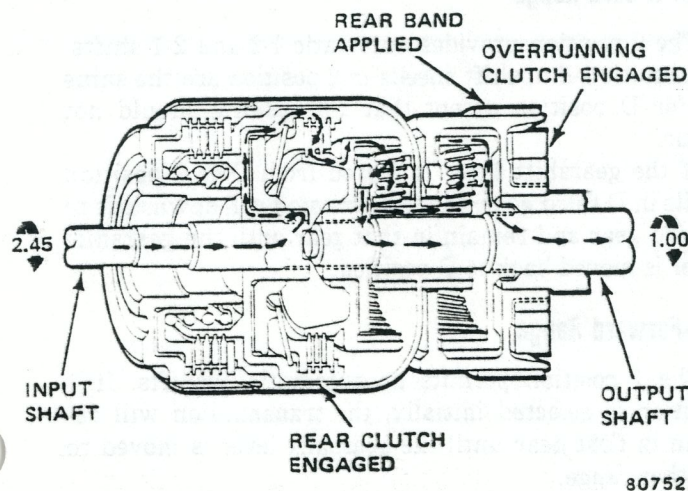

Fig. 2C-14 Torque Flow in Manual First Gear 1 Position

control valve maintains both converter operating pressure and transmission lubrication pressure. The pressure regulator and converter control valves are located in the valve body.

The governor valve is operated by the output shaft and controls line pressure and shift speeds. Since the governor is operated by the output shaft, governor pressure increases in almost direct proportion to vehicle speed.

The throttle valve also controls upshift and downshift speeds by regulating pressure in conjunction with throttle position.

### **Shift Valves**

The manual valve is actuated by the gearshift linkage and provides the drive ranges selected by the operator. The 1-2 shift valve provides automatic 1-2 or 2-1 shifts. The 2-3 shift valve provides automatic 2-3 and 3-2 shifts. The kickdown valve provides forced 3-2 or 3-1 downshifts depending on vehicle speed. Downshifts occur when the throttle is opened beyond downshift detent position, which is just before wide open throttle.

The 2-3 shift valve throttle pressure plug provides 3-2 downshifts with varying throttle openings depending on vehicle speed. On 999 models, the 1-2 shift control valve sends 1-2 shift control pressure to the accumulator piston to control front band capacity on 1-2 upshifts and 3-2 downshifts. The limit valve controls the maximum speed at which a 3-2 part throttle downshift can be made.

The shuttle valve has two independent functions. First is fast front band release and smooth front clutch engagement during "lift foot" 2-3 upshifts. Second is to regulate front servo and band application during 3-2 downshifts.

### **Clutches, Bands, Servos, Accumulator**

The front and rear clutch pistons and servo pistons are actuated by line pressure. When line pressure is removed, the pistons are released by spring tension.

On 2-3 upshifts, the front servo piston is released by spring tension and hydraulic pressure. The accumulator controls hydraulic pressure on the apply side of the front servo during 1-2 shifts and serves to cushion front band application at all throttle openings.

## **GEARSHIFT LEVER POSITIONS**

### **Park (P)**

In Park position the transmission output shaft is mechanically locked by the internal parking linkage. The vehicle must be completely stopped before engaging the transmission in Park.

**CAUTION:** *Internal damage to the transmission could result by shifting the transmission into Park position while the vehicle is moving, or by moving the vehicle with the transmission engaged in Park position.*

### **Reverse (R)**

When shifted to the R position, the reverse gears are engaged providing the reverse direction of movement necessary for backing and parking maneuvers.

### **Neutral (N)**

In Neutral position, forward or reverse movement will not occur. The engine can be started in Neutral as well as Park. However, the transmission is not locked mechanically in Neutral as it is in Park position.

### **D—Forward Range**

The D position provides automatically shifted forward ranges which are: 1-2 and 2-3 upshifts and 3-2 and 3-1 downshifts. The 3-2 and 3-1 downshifts occur at various vehicle speeds depending on throttle opening. Approximate shift speeds for various modes of operation are shown in the Automatic Shift Speed and Governor Pressure Chart.

For extra acceleration in D position third gear, above approximately 30 mph (48 km/h) and below approximately 70 mph (113 km/h), completely depress the accelerator. This forces a 3-2 downshift. The transmission will remain in second gear until full throttle automatic upshift speed is attained or the accelerator pedal is released. If the accelerator pedal completely depressed while in third gear below approximately 30 mph (48 km/h), a 3-1 downshift should occur. Upshifts to second and third gears occur at full throttle automatic upshift speeds or when the accelerator pedal is released.

### **2—Forward Range**

The 2 position provides automatic 1-2 and 2-1 shifts. Automatic 1-2 upshift speeds in 2 position are the same as for D position except that 2-3 upshifts should not occur.

If the gearshift lever is moved from D to 2 position while in D third gear, the transmission will downshift to second gear and remain in that gear until the gearshift lever is moved back to D position.

### **1—Forward Range**

The 1 position permits no automatic upshifts. If 1 position is selected initially, the transmission will remain in first gear until the gearshift lever is moved to another range.

If the gearshift lever is moved from D or 2 to 1 while the vehicle is in second gear at a speed below the full

throttle 1-2 upshift point, the transmission will downshift to first gear. If vehicle speed is above 1-2 full throttle shift point, the transmission will remain in second gear until speed is reduced to the 1-2 full throttle shift point.

If the gearshift lever is moved from D to 1 position at speeds below approximately 30 mph (48 km/h), the transmission will downshift to first gear.

## PERIODIC MAINTENANCE

For normal operation, the automatic transmission should be serviced every 25 months or 25,000 miles (40 000 km). Service should include changing the transmission fluid and filter and if necessary, adjusting the bands. For heavy-duty operation such as trailer towing, the transmission fluid and filter should be changed and the bands adjusted, if necessary, at 10 months or 10,000 mile (16 000 km) intervals.

## TOWING

### Emergency Towing

If the vehicle is to be towed with the front or rear wheels raised, towing speed must be limited to 30 mph (48 km/h) and the vehicle towed for a distance no greater than 15 miles (24 km).

### Manual Transmission with Model 208 and Model 300 Transfer Case

**Ignition Key Available:** Shift transmission and transfer case into Neutral. Vehicle can now be towed with all four wheels on the ground or with front or rear wheels raised. Turn selective drive hubs to the 4 x 4/LOCK position. Turn ignition key to Off position to unlock steering.

**Ignition Key Not Available and Vehicle is Unlocked:** Shift transmission and transfer case into Neutral and tow vehicle with front wheels raised.

**Ignition Key Not Available and Vehicle is Locked:** Place dolly under rear wheels and tow vehicle with front end raised. Or, disconnect rear propeller shaft at rear axle yoke (be sure to mark the prop shaft and yoke for proper alignment at reassembly), secure shaft to underside of vehicle and tow with front end raised.

### Automatic Transmission with Model 208 and Model 300 Transfer Case

**Ignition Key Available:** Turn ignition key to Off position to unlock steering column and gearshift selector linkage. Move gearshift lever to Park and transfer case shift lever to Neutral.

**Ignition Key Not Available:** Place dolly under rear wheels and tow vehicle with front end raised. Or, disconnect rear propeller shaft at rear axle yoke (index mark for correct assembly later), secure shaft to underside of vehicle and tow with front wheels raised.

### Automatic Transmission with Quadra-Trac®

**Ignition Key Available:** Vehicle can be towed with all four wheels on the ground without disconnecting propeller shafts. Turn ignition key to Off position to unlock steering wheel. Move gearshift lever to Park and shift transfer case shift lever to Neutral position.

## Recreational Towing

Jeep vehicle can be towed behind a recreational vehicle such as a motor home, however, the following instructions must be followed explicitly in order to avoid damaging drive line components. In addition, be sure to check and comply with federal, state and local requirements/ordinances regarding vehicle lighting, tow bars and trailer hitches.

### With Manual Transmission and Model 208 or Model 300 Transfer Case

- (1) Turn ignition switch to Off position to unlock steering wheel.
- (2) Shift transmission into gear and the transfer case into Neutral.
- (3) Turn front drive hubs to 4 x 4 or LOCK position, for axle lubrication.

### With Automatic Transmission and Model 208 or Model 300 Transfer Case

- (1) Turn ignition switch to Off position to unlock steering wheel.
- (2) Shift automatic transmission into Park.
- (3) Shift Transfer Case into Neutral position.
- (4) Turn front drive hubs to 4 x 4 or LOCK position for axle lubrication.

### With Automatic Transmission and Quadra-Trac®

- (1) Turn ignition switch to Off position to unlock steering wheel.
- (2) Shift automatic transmission into Park.
- (3) Shift Transfer Case into Neutral position.

# DIAGNOSIS AND TEST PROCEDURES

|  | Page  |                          | Page  |
|--|-------|--------------------------|-------|
|  | 2C-16 | Hydraulic Pressure Tests | 2C-14 |
| Air Pressure Test                      | 2C-17 | Preliminary Diagnosis    | 2C-12 |
| Converter Housing Fluid Leak Diagnosis | 2C-12 | Road Test                | 2C-13 |
| Fluid Level and Condition              | 2C-13 | Service Diagnosis        | 2C-18 |
| Flushing Oil Cooler and Lines          | 2C-13 | Specifications           | 2C-22 |
| Gearshift Linkage                      | 2C-12 | Stall Test               | 2C-18 |
| General                                | 2C-18 | Throttle Linkage         | 2C-13 |
| Governor Valve                         | 2C-18 |                          |       |

## GENERAL

Automatic transmission malfunctions are generally the result of poor engine performance, incorrect fluid level, incorrect linkage, band or hydraulic control pressure adjustments, hydraulic system malfunctions or mechanical component malfunctions.

In all automatic transmission repair, the logical and proper procedure is diagnosis before disassembly. A systematic diagnosis procedure is important in avoiding repair delays caused by incorrect or unnecessary repairs. The diagnosis and test procedures outlined in this section should be performed in the following sequence to realize maximum effect: (1) preliminary diagnosis, (2) road test, (3) hydraulic pressure test, (4) air pressure test, (5) stall test, (6) analyze test results and consult diagnosis guides and charts for cause of malfunction.

## PRELIMINARY DIAGNOSIS

Two basic procedures are required. One procedure for vehicles that are driveable and an alternate procedure for vehicles that will not back up or move forward.

### Vehicle Is Driveable

- (1) Check fluid level and condition.
- (2) Adjust throttle and gearshift linkage before road testing if complaint was based on delayed, erratic, or harsh shifts.
- (3) Perform stall test if complaint was based on sluggish, low-speed acceleration or abnormal throttle opening requirements to maintain highway speeds with engine in good tune.
- (4) Road test vehicle and analyze results.
- (5) Perform hydraulic pressure tests.
- (6) Perform air pressure test to check clutch and band operation.

### Vehicle Will Not Back Up or Move Forward

- (1) Check fluid level and condition.
- (2) Check for broken or disconnected throttle linkage.
- (3) Check for broken cooler lines and loose or missing pressure port plugs.

(4) Raise vehicle, start engine, shift transmission into gear and note following:

(a) If propeller shafts turn but wheels do not, problem is in differential or axle shafts.

(b) If propeller shafts do not turn and transmission is noisy, stop engine, remove oil pan, and check for debris. If debris is not found, remove transmission and check for broken drive plate or drive plate-to-converter bolts, broken converter hub, broken input or output shaft or broken oil pump.

(c) If propeller shafts do not turn and transmission is not noisy, perform hydraulic pressure test to determine if problem is malfunction of hydraulic or mechanical component.

## FLUID LEVEL AND CONDITION

Check fluid level and condition as follows:

(1) Drive vehicle until transmission fluid is at normal operating temperature of approximately 175°F (79.4°C).

**NOTE:** To avoid false readings, which could result in an over or under-fill condition, do not check the fluid level until the fluid is at operating temperature.

(2) Shift transmission into Neutral.

**NOTE:** The transmission fluid level is checked in Neutral because the converter fills more rapidly in this position.

(3) Apply parking brake.

(4) Operate engine at idle speed.

(5) Wipe dirt from filler cap and tube before removing dipstick.

**WARNING:** Be sure to keep hands or loose articles of clothing away from the fan, accessory drive belts, or other rotating engine parts. Contact with these components or hot engine components can result in personal injury.

(6) Remove dipstick and check fluid level. Fluid level is correct when between ADD ONE PINT and FULL marks on dipstick.

(7) Add or drain fluid as necessary to bring fluid to correct level. If level was low, check transmission for leaks.

(8) Check condition of fluid.

(a) Fluid should be dark red in color and free of dirt or debris.

(b) If fluid is discolored or smells burnt, but transmission operation is OK, fluid and filter should be replaced.

(c) If fluid is badly discolored, smells burnt, contains metal or frictional material particles and transmission problems were experienced, transmission may require overhaul.

A low fluid level allows the pump to take in air along with the fluid. As in any hydraulic system, aerated fluid will cause hydraulic pressures to be low and develop slower than normal.

If the transmission is overfilled, the gears churn the fluid into foam aerating the fluid and causing the same conditions that occur with a low fluid level. In either case, air bubbles cause fluid overheating, oxidation and varnish buildup which interferes with valve, clutch and servo operation. Foaming can also result in fluid escaping from the transmission vent where it may be mistaken for a leak.

Along with fluid level, it is also important to check fluid condition. When the fluid is dark, smells burnt or is contaminated with metal or frictional material particles, an overhaul may be necessary. Examine the fluid on the dipstick closely. If there is any doubt about its condition, drain out a sample for further inspection.

After checking fluid level and condition, seat the dipstick fully to seal out water and dirt.

**NOTE:** After completing any repairs that required draining the transmission fluid, add 8 pints (4.5 liters) of Jeep, Dexron, or equivalent automatic transmission fluid to the transmission before starting the engine.

## FLUSHING OIL COOLER AND COOLER LINES

If a transmission or lockup clutch failure has contaminated the fluid, the oil cooler(s) should be reverse flushed to insure that metal particles or sludged oil are not later transferred back into the reconditioned transmission.

(1) Disconnect both cooler lines at radiator.

(2) Dislodge any foreign material at inlet side of cooler with small screwdriver.

(3) Reverse flush cooler with combination of mineral spirits and pulsating air under pressure (shop air).

(4) Treat cooler lines separately and insure they are clear by flowing mineral spirits or automatic transmission fluid through them.

(5) Remove leftover mineral spirits from cooler and cooler lines by flowing automatic transmission fluid through them.

(6) Cooler flow should now be checked by connecting cooler tubes and placing rear cooler tube into 1 quart container. Overfill transmission by 1 quart. Watching a clock, start engine (run at curb idle) and run in neutral for exactly 20 seconds. If cooler flow is less than 1 quart in 20 seconds, replace radiator or have radiator bottom cooler professionally reconditioned.

## THROTTLE LINKAGE

The throttle linkage adjustment is important to proper operation. This adjustment positions a valve which controls shift speed, shift quality, and part throttle downshift sensitivity. If the setting is too short, early shifts and slippage between shifts may occur. If the linkage setting is too long, shifts may be delayed and part throttle downshifts may be very sensitive.

This adjustment is so critical that the use of a throttle lever holding spring is necessary to remove slack in the linkage during adjustment. Refer to Throttle Linkage Adjustment in In-Vehicle Service and Adjustment.

## GEARSHIFT LINKAGE

The gearshift linkage adjustment is important because the linkage positions the manual valve in the valve body. Incorrect adjustment will result in creeping in Neutral, premature clutch wear, delayed engagement in any gear or a no-start in Park or Neutral condition.

Proper operation of the neutral start switch will provide a quick check of linkage adjustment as follows:

(1) Insert key in ignition lock and turn lock to On position to unlock column and gearshift lever.

(2) Move gearshift lever slowly upward until it clicks into Park detent in shift selector gate.

(3) Turn ignition lock cylinder to Start position and start engine. If starter operates, Park position is correct.

(4) Stop engine.

(5) Move gearshift lever slowly toward Neutral until lever engages in edge of Neutral detent in shift selector gate.

(6) Turn ignition lock cylinder to Start position and start engine. If starter operates, Neutral position is correct and linkage is properly adjusted.

(7) If starter failed to operate in Park or Neutral, or if gearshift lever had to be moved back and forth to achieve start in either position, linkage adjustment is required. Refer to Gearshift Linkage Adjustment in In-Vehicle Service and Adjustment section.

## ROAD TEST

Before road testing, be sure fluid level, throttle and gearshift linkage adjustments have been checked and corrected if necessary.

Observe engine performance during the test. An engine malfunction will have an adverse effect on transmission operation. In addition, operate the transmission

in all gearshift positions to check for slippage and shift variations. Note whether the shifts are harsh or spongy, and check the speeds at which upshifts and downshifts occur.

Watch closely for slippage or engine speed flare-up which usually indicates clutch, band or overrunning clutch problems. If the condition is advanced, an overhaul may be necessary to restore normal operation.

In most cases, a slipping clutch or band can be determined by noting transmission operation in all gearshift lever positions and by comparing which internal units are applied in those positions. The Clutch and Band Application Chart provides a basis for analyzing road test results.

**Clutch and Band Application Chart**

| Drive Elements     | Gearshift Lever Position |   |   |   |   |   |   |   |   |
|--------------------|--------------------------|---|---|---|---|---|---|---|---|
|                    | P                        | R | N | D |   |   | 2 |   | 1 |
|                    |                          |   |   | 1 | 2 | 3 | 1 | 2 |   |
| Front Clutch       |                          | • |   |   |   | • |   |   |   |
| Front Band         |                          |   |   | • |   |   |   | • |   |
| Rear Clutch        |                          |   | • | • | • | • | • | • | • |
| Rear Band          |                          | • |   |   |   |   |   |   | • |
| Overrunning Clutch |                          |   | • |   |   |   | • |   | • |

60230

**Analyzing the Road Test**

Refer to the Clutch and Band Application Chart and note which elements are in use in the various gear ranges. The rear clutch is applied in all forward ranges (D, 2, 1). The overrunning clutch is applied in first gear D and 2 range only and the front band is applied in 1 and R range only.

For example, if slippage occurs in D and 2 range first gear but not in 1 range, the overrunning clutch is slipping. Similarly, if slippage occurs in any two forward gears, the rear clutch is slipping.

Applying the same method of analysis, note that both clutches are applied in D third gear only. If the transmission slips in third gear, either the front clutch or the rear clutch is slipping. By selecting another gear which does not use one of these units, the slipping clutch can be determined. For example, if the transmission also slips in reverse, the front clutch is slipping. If the transmission does not slip in reverse, the rear clutch is slipping.

This process of elimination can be used to determine the slipping unit and to check operation. The key is proper use of the Clutch and Band Application Chart.

Although road test analysis will help determine the slipping unit, the actual cause of a malfunction usually cannot be ascertained until hydraulic and air pressure tests are performed. Practically any condition can be caused by leaking hydraulic circuits or sticking valves.

Unless the condition is obvious, such as no drive in D range first gear only, do not disassemble the transmission until hydraulic and air pressure tests have been performed.

**HYDRAULIC PRESSURE TESTS**

The hydraulic pressure tests are performed using Test Set J-24027. The set consists of five color-coded pressure hoses, a 400 psi (2 758 kPa) capacity pressure gauge and a 100 psi (689 kPa) capacity pressure gauge (fig. 2C-16). The high pressure gauge is used to record rear servo pressure on R and 1 positions only and the low pressure gauge is used for all other readings. The test set permits simultaneous connection to all the pressure ports and allows sequential or independent pressure readings as desired.

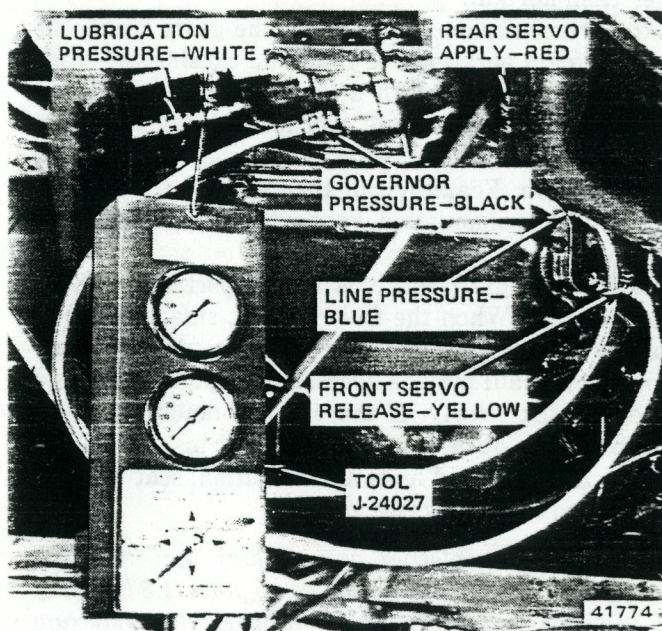

**Fig. 2C-16 Pressure Test Set J-24027**

**Pressure Test Port Location**

The accumulator line pressure port is located on the right side of the case between the front and rear servo castings just above the oil pan mating surface (fig. 2C-17).

The front servo release pressure port is located on the right side of the case just behind the filler tube opening just above the oil pan mating surface (fig. 2C-17).

The rear servo apply pressure port is on the right rear side of the case, facing rearward and just above the oil pan mating surface (fig. 2C-18).

The governor pressure port faces to the left side in the front lower center section of the adaptor housing (fig. 2C-18).

Lubrication pressure is measured by installing a T-fitting in the fluid cooler return line on the left side at

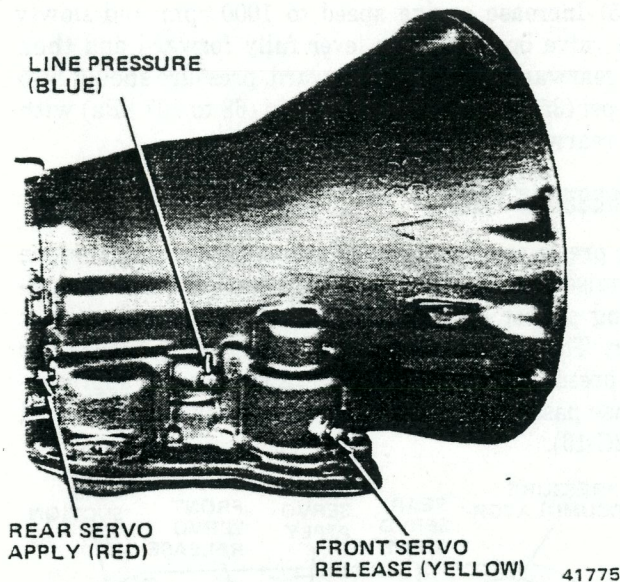

Fig. 2C-17 Pressure Port Locations

the rear edge of the case halfway to the top of the case (fig. 2C-18). If inaccessible, use T-fitting at radiator cooler return line.

### Hydraulic Pressure Test Procedure

Before the test, check and correct fluid level and control linkage adjustments, and connect a tachometer to the engine. Raise the vehicle on a hoist that will allow the wheels to rotate freely and connect the test gauge hoses to the appropriate transmission pressure ports.

#### Test One

This test checks pump output, pressure regulator valve operation, front/rear clutch and oil filter condition by measuring transmission operating pressure at the accumulator and front servo pressure ports in range.

- (1) Turn test gauge selector handle to line pressure position.
- (2) Start and operate engine at idle speed, move gearshift lever to D range and note line pressure.
- (3) At idle, pressure should be 54 to 60 psi (372 to 414 kPa).
- (4) Increase engine rpm to 1600 and slowly move valve body throttle lever fully forward then fully rearward. With throttle lever in forward position, pressure should be 54 to 60 psi (372 to 414 kPa) and gradually increase to 94 psi (648 kPa) when lever is moved rearward.
- (5) Turn test gauge selector handle to front servo apply position.
- (6) Operate engine at 1000 rpm, allow transmission to upshift into third gear, and note servo pressure. Pressure should not vary from previously noted line pressure by more than 3 psi (21 kPa).
- (7) Slowly move throttle linkage to full throttle position and note servo pressures just prior to and after

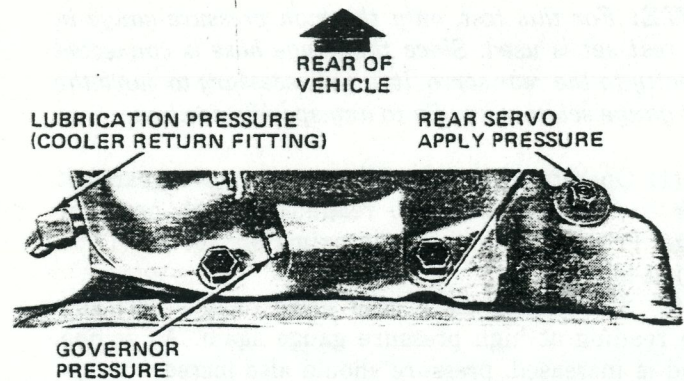

Fig. 2C-18 Pressure Port Locations

transmission downshifts. Servo pressure should increase then drop to 0 psi after downshift.

#### Test Two

This test checks pump output, pressure regulation, and front clutch/rear servo condition by measuring and comparing operating pressures at the rear servo and accumulator pressure ports in gear ranges 1 and 2.

- (1) Turn test gauge selector handle to line pressure position.
- (2) Move gearshift lever to 1 range, operate engine at 1000 rpm, and slowly move valve body throttle lever fully forward then fully rearward. With lever in forward position, pressure should be 54 to 60 psi (372 to 414 kPa) and gradually increase to 90 to 96 psi (621 to 662 kPa) as lever is moved rearward.
- (3) Turn test gauge selector handle to rear servo apply position.
- (4) Operate engine at 1000 rpm. Slowly move valve body throttle lever fully forward then fully rearward. Compare pressure registered at servo with line pressure recorded at accumulator port. Servo pressure should not vary from line pressure by more than 3 psi (21 kPa).
- (5) Turn test gauge selector handle to line pressure position.
- (6) Place gearshift lever in 2 range and operate engine at 1000 rpm.
- (7) Slowly move valve body throttle lever fully forward then fully rearward and note pressures. With lever in forward position, pressure should be 54 to 60 psi (372 to 414 kPa) and gradually increase to 90 to 96 psi (621 to 662 kPa) as lever is moved rearward.

#### Test Three

This test checks pump output, pressure regulation, and front clutch/rear servo condition by measuring and comparing operating pressure at the rear servo pressure port in Reverse.

**NOTE:** For this test, only the high pressure gauge in the test set is used. Since the gauge hose is connected directly to the rear servo, it is not necessary to move the test gauge selector handle to any specific position.

(1) Operate engine at idle speed, move gearshift lever to Reverse, and note reading on high pressure gauge. Pressure should be approximately 160 psi (1 103 kPa) at idle.

(2) Slowly increase engine speed to 1600 rpm and note reading at high pressure gauge again. As engine speed is increased, pressure should also increase to approximately 270 psi (1 862 kPa).

(3) Operate engine at idle speed, move gearshift lever from Reverse to Drive, and note reading at high pressure gauge. Pressure should drop to 0 psi when gearshift lever is moved to Drive. This test checks for leakage into rear servo which can cause rear band burnout.

#### Test Four

This test checks governor operation by measuring governor pressure response to changes in engine speed. It is usually not necessary to check governor operation unless shift speeds are incorrect or if the transmission will not downshift.

(1) Turn test gauge selector handle to governor pressure position.

(2) Move gearshift lever to D range, operate engine at idle speed, and note pressure. Pressure should be 0 to 1-1/2 psi (10 kPa) maximum. If pressure exceeds maximum, governor valve or weights are sticking open.

(3) Slowly increase engine speed and observe speedometer and test gauge pressure. Governor pressure should increase in proportion to vehicle speed (approximately 1 psi per 1 mph). Pressure rise should be smooth and drop back to 0 to 1-1/2 psi (10 kPa) when throttle is closed.

#### Test Five

This test checks lubrication pressure which is measured by connecting the white test gauge hose to a T-fitting that has been inserted in the left-side cooler line. This test is especially important when the transmission is noisy, or unexplained rear clutch failure has occurred, or when fluid is forced out the fill tube and fluid level was known to be correct.

(1) Install T-fitting in transmission cooler line.

(2) Connect white test gauge hose to T-fitting and turn test gauge selector handle to lubrication pressure position.

(3) Start and operate engine at idle speed, move gearshift lever to D range, and note pressure.

(4) Pressure at idle speed should be 5 to 15 psi (35 to 103 kPa).

(5) Increase engine speed to 1000 rpm and slowly move valve body throttle lever fully forward and then fully rearward. With lever forward, pressure should be 5 to 15 psi (35 to 103 kPa) 10 to 30 psi (68 to 207 kPa) with lever rearward.

### AIR PRESSURE TEST

Air pressure testing is used as a diagnostic tool before transmission removal and also as a method of confirming proper clutch, band and servo operation after repair. The tests involve substituting air pressure for fluid pressure by applying air pressure to the appropriate case passages after the valve body has been removed (fig. 2C-19).

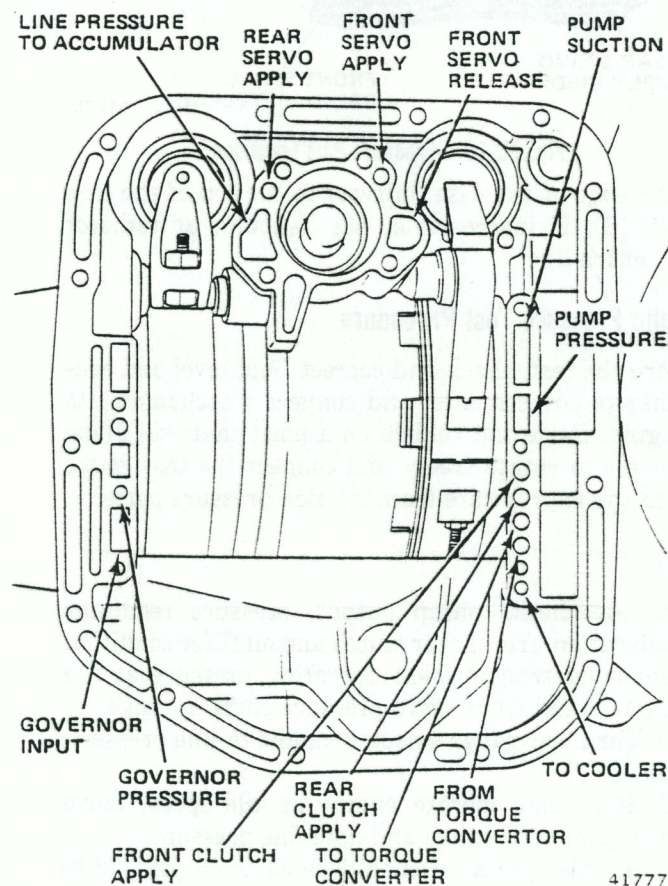

Fig. 2C-19 Transmission Case Channels

**CAUTION:** Use dry, filtered compressed air only when performing air pressure tests. Pressures of 30 to 100 psi (207 to 689 kPa) are required to perform the tests.

#### Front Clutch Test

Place one or two fingers on the clutch housing and apply air pressure to the front clutch apply passage. Movement of the piston can be felt and a soft thud may be heard as the clutch applies. While air pressure is applied, check for excessive air leakage.



### Rear Clutch Test

Place one or two fingers on the clutch housing and apply air pressure to the rear clutch apply passage. Movement of the piston can be felt and a soft thud may be heard as the clutch applies. While air pressure is applied, check for excessive or unusual air leakage.

### Front Servo Test

Apply air pressure to the front servo apply passage. The servo rod should extend and cause the band to tighten around the drum. While air pressure is applied, check for excessive air leakage. Spring tension should release the servo when air pressure is removed.

### Rear Servo Test

Apply air pressure to the rear servo apply passage. The servo rod should extend and cause the band to tighten around the drum. While air pressure is applied, check for excessive air leakage. Spring tension should release the servo when air pressure is removed.

## CONVERTER HOUSING FLUID LEAK DIAGNOSIS

When diagnosing converter housing fluid leaks, two facts must be established before attempting repair. First, it must be verified that a leak condition does actually exist and second, the real source of the leak must be determined. Failure to establish these facts beforehand can result in incorrect or unnecessary repairs.

In some cases, suspected converter housing fluid leaks may not be leaks at all. They may be the result of residual fluid in the converter housing or excess fluid spilled during factory filling or initial transmission operation. These conditions may be incorrectly diagnosed as fluid leaks.

Converter housing area leaks may have several sources. Through careful observation, it is possible to pinpoint the leak source before removing the transmission. The paths various types of fluid leaks follow are shown in figure 2C-20 and are described below.

- Oil Pump Seal—leaks past the seal lip tend to move along the drive hub and onto the rear of the converter housing. However, if total seal failure occurs, fluid will be deposited inside the converter housing only, near the outside diameter of the housing.
- Oil Pump Body—leaks past the pump body follow the same path as an oil pump seal leak or fluid may travel down the pump face into the converter housing.
- Oil Pump-to-Case Bolt—leaks past any one of these bolts are deposited on the inside of the converter housing only and not on the converter itself.
- Oil Pump-to-Case Gasket—leaks past the gasket are deposited inside the converter housing only.

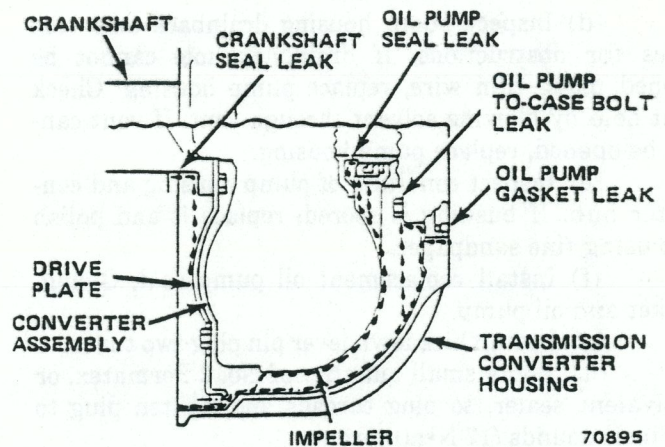

Fig. 2C-20 Converter Housing Fluid Leak Diagram

- Front Band Lever Pin Plug—leaks past the plug threads are deposited inside the housing and not on the converter.

### Leak Diagnosis Procedure

- (1) Check fluid level and condition. If fluid level is high or low, adjust to proper level.
- (2) Raise and support vehicle.
- (3) Inspect transmission and correct any external leaks from oil pan gasket, filler tube, governor line to TCS switch, if equipped, cooler line fittings, pressure test port plugs and case-to-adaptor housing gasket.
- (4) Remove converter housing spacer plate.
- (5) Wipe all fluid from converter housing area.
- (6) Operate engine at 2000 rpm for 2 minutes and observe converter housing for fluid accumulation pattern.
- (7) If fluid accumulation pattern is not evident, proceed to next step.
- (8) If a circular pattern develops, it indicates a defective or damaged torque converter. Correct leak by replacing converter.
- (9) If a trickle develops, it indicates an oil pump leak caused by one or more of the following conditions:
  - Pump drainback hole obstructed.
  - Pump housing vent obstructed.
  - Pump bushing or converter hub scored, nicked, pitted or burred.
  - Defective oil pump O-ring, gasket, or seal.
  - Front band lever pin plug loose or plug threads in case are stripped.
- (10) Correct these conditions as outlined in following steps.
  - (a) Remove transmission and converter.
  - (b) Tighten front band adjusting screw until band is tight around front clutch retainer. This will prevent front clutch assembly from also coming out when oil pump is removed and prevent damaging clutch discs.
  - (c) Remove oil pump and oil seal.

(d) Inspect pump housing drainback and vent holes for obstructions. If drainback hole cannot be opened using thin wire, replace pump housing. Check vent hole by blowing solvent through vent. If vent cannot be opened, replace pump housing.

(e) Inspect condition of pump housing and converter hub. If bushing is scored, replace it and polish hub using fine sandpaper.

(f) Install replacement oil pump seal, O-ring, gasket and oil pump.

(g) Loosen kickdown lever pin plug two turns.

(h) Apply small quantity of No. 2 Permatex, or equivalent sealer, to plug threads and tighten plug to 150 inch-pounds (17 N•m) torque.

(i) Adjust front band.

(11) Install transmission and converter.

(12) Install converter housing spacer plate.

(13) Remove supports and lower vehicle.

## GOVERNOR

Governor operational problems should be diagnosed using the road test and hydraulic pressure test procedures.

## STALL TEST

Stall testing determines the maximum engine rpm obtainable at full throttle with the rear wheels locked and the transmission in Drive. Stall testing also checks the holding ability of the converter-stator overrunning clutch and both transmission clutches. When stall testing is completed, refer to the Stall Speed Specifications Chart and diagnosis guides.

**WARNING:** *Never allow anyone to stand in front of the vehicle when performing a stall test. In addition, always block the front wheels and have the parking and service brakes fully applied during the test.*

(1) Connect tachometer to engine.

(2) Check and adjust transmission fluid level as necessary.

(3) Start and operate engine until transmission fluid reaches operating temperature.

(4) Block front wheels.

(5) Fully apply parking brakes.

(6) Fully apply service brakes.

(7) Open throttle completely and record maximum engine rpm registered on tachometer.

**CAUTION:** *Do not hold the throttle open any longer than necessary and never longer than five seconds at a time. If more than one stall test is required, operate the engine at 1000 rpm with the transmission in Neutral for at least 20 seconds to cool the transmission fluid.*

(8) If engine speed exceeds maximum shown in stall speed chart, release accelerator immediately. This indicates that transmission clutch slippage is occurring.

(9) Shift transmission into Neutral, operate engine for 20 seconds, stop engine, shift transmission into Park, and release brake.

(10) Compare test results with stall speed chart and refer to stall test diagnosis.

## Stall Test Diagnosis

### Stall Speed Too High

If stall speed exceeds specifications by more than 200 rpm, transmission clutch slippage is indicated.

### Stall Speed Too Low

Low stall speeds with a properly tuned engine indicate a torque converter stator clutch problem. The condition should be confirmed by road testing prior to converter replacement. If stall speeds are 250-350 rpm below the minimum specified in the chart, and the vehicle operates properly at highway speeds but has poor low speed acceleration, the stator overrunning clutch is slipping and the torque converter should be replaced.

### Stall Speed Normal

If stall speeds are normal but road testing shows that abnormally high throttle opening is required to maintain highway speeds even though low speed acceleration is normal, the stator overrunning clutch is seized and the torque converter must be replaced.

### Noise

A whining or siren-like noise caused by fluid flow is normal during a stall test. Loud metallic noises from loose internal parts or interference within the assembly indicates a defective torque converter. To confirm that a noise is originating from within the converter, operate the vehicle at light throttle in Drive and Neutral on a hoist and listen for noise coming from the torque converter housing.

When the stall test is completed, compare the test speeds recorded with those listed in the Stall Speed Specifications Chart.

## SERVICE DIAGNOSIS

### General

The diagnosis charts provide a quick reference for transmission diagnosis. A step-by-step approach to diagnosing and correcting transmission malfunctions is used.

The In-Vehicle Procedures chart lists problem conditions that can be corrected with the transmission in the vehicle. The Out-Of-Vehicle Procedures chart lists problems that require transmission removal and disassembly.

### Stall Speed Specifications Chart

| Transmission Model | Engine RPM |
|--------------------|------------|
| 999                | 1700-2000  |
| 727                | 1700-2000  |
| 904                | 2050-2350  |

60232

The In-Vehicle Procedures should always be performed first. Do not remove the transmission unless the In-Vehicle Procedures fail to correct the problem.

### How to Use the Charts

The *Condition* columns in each chart describes the most frequently encountered malfunctions. Each problem condition is cross-referenced to the necessary service procedures.

The code letters in the boxes at the top of each chart identify the individual service procedures. These code letters correspond to descriptions of the various procedures, which appear on the pages immediately following the charts.

Capital letters A through T denote In-Vehicle Procedures. Lower case letters a through j denote Out-Of-Vehicle Procedures.

The numbers in the boxes adjacent to the *Condition* column cross-reference each problem condition to the necessary service procedures. These numbers also show the order in which the various service procedures should be performed.

As an example, assume that the problem condition is Harsh Engagement in R-D-2-1. First, locate the problem description in the *Condition* column; then note which service procedures are indicated. As shown in the chart, procedures B, D, E, G, N, Q are required. Next, note the numbers which indicate the sequence in which these procedures are to be performed. In this case, the correct order will be D, B, E, G, Q, N. Finally, refer to the service procedure descriptions, which appear on the pages immediately following the charts, for details of each procedure.

Become familiar with both charts and the procedures required. Some conditions require in-vehicle service only, others require out-of-vehicle service only, and some require a combination of both.

### In-Vehicle Procedures

**A**—Fluid Level and Condition: Fluid should be at full mark with engine idling. Fluid should not be milky, full of bubbles, or dark and burnt smelling. Use AMC, Dexron, or equivalent, transmission fluid only.

**B**—Throttle Linkage: Check for smooth travel. Clean, but do not lube, linkage pivot points as necessary, then adjust to specifications.

**C**—Gearshift Linkage: Adjust to specifications.

**D**—Engine Idle Adjustment: Set to specifications.

**E**—Hydraulic Pressures: Perform hydraulic pressure test to determine if operating pressures are within specifications. Repair hydraulic components as necessary. Check and correct throttle and line pressure settings if required.

**F**—Front Band: Adjust to specifications.

**G**—Rear Band: Adjust to specifications.

**H**—Neutral Start Switch: Check wires and connections. Test switch. See if valve body manual lever grounds switch in P and N positions. If not OK, check ground strip at valve body manual lever. If OK, check starting circuit.

**I**—Park Lock: Check condition of lock rod, lock rod ball, sprag reaction plug, governor support and sprag shaft. Replace parts as required.

**J**—Transmission Oil Cooler: Check lines and cooler for obstructions or leaks (look for transmission fluid in radiator coolant or milky colored transmission fluid which indicates coolant in fluid).

**K**—Output Shaft Bearing, Bushing or Seal: Remove extension housing, inspect parts, and replace parts as necessary.

**L**—Governor Valve: Clean and inspect all parts. Check weights, shaft and valve for burrs, nicks, scores or binding. Check spring for collapsed or distorted coils and snap rings for distortion. Check filter for dirt and debris. Inspect body for cracks or warpage. Check torque on governor and output shaft support bolts.

**M**—Oil Filter: Inspect and replace if clogged.

**N**—Valve Body: Remove, disassemble, clean thoroughly, and inspect valves and plugs for nicks, scratches, burrs, and rounded edges on valve lands. Check bores for scratches, springs for collapsed coils, and all mating surfaces for nicks, burrs or warpage. Reassemble and install, tightening all screws to exact specifications.

**O**—Front Servo and Linkage: Inspect piston for wear, cracks, and worn or broken seal rings. Check springs for collapsed or broken coils. Check servo bore for scratches, nicks or wear. Check lever, strut, and band for damage. Check lever shaft for wear, being loose in case, or for leaking O-ring.

**P**—Rear Servo and Linkage: Inspect piston for wear, cracks, worn or broken seal ring or damaged seal. Check springs for collapsed or broken coils. Check servo bore for scratches, nicks or wear. Check lever and band for damage. Check lever shaft for wear or looseness in case.

**Q**—Accumulator: Clean and inspect for broken seal rings, scratched bore, broken or collapsed spring. Check piston for cracks or evidence of piston cocking in bore.

**R**—Air Pressure Test: Remove valve body and use air pressure to apply clutches and bands to check operation.

**S**—Engine Tune and Performance: Verify proper engine operation. Be sure compression meets specifications and fuel and ignition systems are functioning properly.

T—Stall Test: Perform stall test to check holding ability of converter and transmission clutches.

**Out-Of-Vehicle Procedures**

a—Converter Drive Plate: Check plate for flatness, cracks at mounting bolt holes, loose attaching bolts or damaged ring gear teeth. Broken drive plate may indicate engine-to-transmission caused by loose, missing or misaligned dowels.

b—Oil Pump: Clean pump and check all clearances. Inspect rotors for scoring and the seal and bushings for wear. Inspect pump housing and reaction shaft support mating surfaces for flatness.

c—Transmission Vent: Make sure vent is open and not obstructed.

d—Front Clutch: Clean and inspect all parts. Examine retainer and piston for scores and scratches, discs and plates for wear, return springs for collapsed coils, and the seal rings for damage. The vent check ball in the retainer must operate freely.

e—Rear Clutch: Inspect all rear clutch parts as outlined under front clutch procedure.

f—Planetary Gear Set: Clean and inspect annulus gear, planet pinion carrier assembly, and sun gear for worn thrust washers, damaged gear teeth, and excessive pinion end clearance. Examine the bushings in the sun gear for excessive wear.

g—Rear Band: Inspect the band for wear and for good bond of lining to band. Inspect lining for burn marks, glazing, uneven wear patterns, flaking, or if band

**Service Diagnosis**

**OUT OF VEHICLE PROCEDURES**

| CONDITIONS   | a | b | c | d | e | f | g | h | i | j |
|--|---|---|---|---|---|---|---|---|---|---|
| HARSH ENGAGEMENT R, D, 2, 1  |   |   |   | 1 | 2 |   |   |   |   |   |
| SLOW TO ENGAGE N, R, D, 2, 1                                       |   | 1 |   | 2 | 3 |   |   |   |   | 4 |
| NO UPSHIFT, STUCK IN LOW GEAR                                      |   | 1 |   | 2 |   |   |   |   |   |   |
| DELAYED, ERRATIC SHIFTS (HARSH AT TIMES)                           |   | 1 |   |   |   |   |   |   |   |   |
| SLIPS IN FORWARD DRIVE RANGES                                      |   | 1 |   | 2 | 3 |   | 4 |   |   | 5 |
| SLIPS IN REVERSE ONLY  |   | 1 |   | 2 |   |   | 3 |   |   |   |
| SLIPS IN LOW GEAR "D" ONLY BUT NOT IN "1" POSITION                 |   |   |   |   |   |   |   | 1 |   |   |
| WILL NOT MOVE IN FORWARD OR REVERSE                                | 1 | 2 |   |   |   | 3 |   |   |   |   |
| REVERSE OK, WILL NOT MOVE FORWARD IN D, 2, 1                       |   |   |   |   | 1 |   |   |   |   |   |
| NO REVERSE   |   |   |   | 1 |   |   | 2 |   |   |   |
| MOVES IN NEUTRAL POSITION (CREEPS IN "N")                          |   |   |   |   | 1 |   |   |   |   |   |
| DRAGS OR LOCKS UP  |   |   |   | 1 | 2 | 3 | 4 | 5 |   |   |
| GROWLING, GRATING OR SCRAPING NOISES                               | 1 | 2 |   | 3 |   | 4 |   | 5 | 6 |   |
| BUZZING NOISE  |   | 1 |   |   |   |   |   |   | 2 |   |
| OIL BLOWS OUT FILLER TUBE  |   | 1 | 2 |   |   |   |   |   |   |   |
| OVERHEATS  | 1 |   |   |   |   |   |   |   |   |   |
| SLUGGISH ACCELERATION, EXCESSIVE THROTTLE NEEDED TO MAINTAIN SPEED |   |   |   |   | 2 |   |   |   | 1 |   |

grooves are worn away at any portion of band. Replace band if it exhibits any of these conditions.

h—Overrunning Clutch: Clean and inspect clutch parts for brinnelled clutch rollers or cam, or improperly assembled rollers or springs. Check for collapsed springs and bent spring retainer tabs.

i—Torque Converter: If the converter hub seal surface or drive slots are damaged or if the converter contains foreign material, burnt-oxidized fluid or debris, replace

the converter. Do not attempt to clean or flush the converter.

j—Seal Rings: Inspect seal rings on reaction shaft support and governor support for wear, cracks or breakage. Inspect ring grooves on both support assemblies for nicks, burrs or distortion. Inspect bores in front clutch retainer and output shaft support for nicks, grooves, wear, cracks or scratches.

Service Diagnosis

IN VEHICLE PROCEDURES

| CONDITIONS   | A | B | C | D | E | F | G | H | I | J | K | L | M | N | O | P  | Q  | R | S | T |
|--|---|---|---|---|---|---|---|---|---|---|---|---|---|---|---|----|----|---|---|---|
| HARSH ENGAGEMENT R, D, 2, 1  |   | 2 |   | 1 | 3 |   | 4 |   |   |   |   |   |   | 6 |   |    | 5  |   |   |   |
| SLOW TO ENGAGE N, R, D, 2, 1                                       | 1 |   | 2 | 3 | 4 |   | 6 |   |   |   |   |   | 5 | 9 |   |    | 8  | 7 |   |   |
| NO UPSHIFT, STUCK IN LOW GEAR                                      | 1 | 2 | 3 |   | 4 | 7 |   |   |   |   |   | 5 | 6 | 8 |   |    |    | 9 |   |   |
| NO LOW GEAR MOVES IN 2ND or 3RD GEAR                               |   |   |   |   |   |   |   |   |   |   |   | 1 | 2 |   |   |    |    |   |   |   |
| NO KICKDOWN OR NORMAL DOWNSHIFT                                    | 1 | 2 | 3 |   | 5 | 4 |   |   |   |   |   | 6 | 7 | 8 |   |    |    | 9 |   |   |
| DELAYED ERRATIC SHIFTS (HARSH AT TIMES)                            | 1 | 2 | 3 |   | 4 | 5 |   |   |   |   |   | 6 | 7 | 8 | 9 | 10 |    |   |   |   |
| SLIPS IN FORWARD DRIVE RANGES                                      | 1 | 2 | 3 |   | 4 | 5 |   |   |   |   |   |   | 6 | 7 | 8 | 9  | 10 |   |   |   |
| SLIPS IN REVERSE ONLY  | 1 |   | 2 |   | 3 |   | 4 |   |   |   |   |   |   | 5 |   | 6  |    | 7 |   |   |
| WILL NOT MOVE IN FORWARD OF REVERSE                                | 1 |   | 2 |   | 3 |   |   |   |   |   |   |   | 4 | 5 |   |    |    |   | 6 |   |
| REVERSE OK, WILL NOT MOVE FORWARD IN D, 2, 1                       |   |   | 1 |   | 2 |   |   |   |   |   |   |   |   | 3 |   |    |    |   | 4 |   |
| NO REVERSE   |   |   | 1 |   | 2 |   | 3 |   |   |   |   |   |   |   |   |    | 4  |   | 5 |   |
| MOVES IN NEUTRAL POSITION (CREEPS IN "N")                          |   |   | 1 |   |   |   |   |   |   |   |   |   |   | 2 |   |    |    |   |   |   |
| DRAGS OR LOCKS UP  |   |   |   |   | 1 | 2 | 3 |   | 4 |   |   |   |   | 5 | 6 | 7  | 8  |   |   |   |
| GROWLING, GRATING OR SCRAPING NOISES                               | 1 |   |   |   |   |   |   |   | 2 | 3 |   | 4 |   |   |   |    |    |   |   |   |
| BUZZING NOISE  | 1 |   |   |   |   |   |   |   |   |   |   | 2 | 3 |   |   |    |    |   | 4 |   |
| OIL BLOWS OUT FILLER TUBE  | 1 |   |   |   |   |   |   |   |   | 2 |   | 3 | 4 |   |   |    |    |   |   |   |
| OVERHEATS  | 1 |   |   | 2 | 5 | 4 | 7 |   |   | 3 |   | 6 | 8 |   |   |    |    |   |   |   |
| WILL NOT START IN N OR P POSITION                                  |   |   | 1 |   |   |   |   |   | 2 |   |   |   |   | 4 |   |    |    |   |   | 3 |
| SLUGGISH ACCELERATION, EXCESSIVE THROTTLE NEEDED TO MAINTAIN SPEED | 1 | 3 |   |   | 5 |   |   |   |   |   |   |   |   |   |   |    |    |   |   | 2 |

## SPECIFICATIONS

## Hydraulic Pressure Test Specifications

|                     |                                  |  |
|---------------------|----------------------------------|--|
| Lube Pressure       | Closed throttle<br>Full throttle | 5-30 psi (34-207 kPa)<br>5-30 psi (34-207 kPa)   |
| Line Pressure       | Closed throttle<br>1000 rpm      | 54-60 psi (372-414 kPa)<br>57-94 psi (393-648 kPa)   |
| Front Servo Release | Third gear only                  | No more than 3 psi (21 kPa) lower than line pressure   |
| Rear Servo Apply    | 1 Range<br>R Range               | No more than 3 psi (21 kPa) lower than line pressure<br>160 psi (1103 kPa) at idle, builds to 270 psi (1862 kPa) at 1600 RPM.  |
| Governor            | D Range<br>Closed throttle       | Pressure should respond smoothly to changes in MPH and return to 0 to 1-1/2 PSI (0-7 kPa) when stopped with transmission in D, 1, 2.<br><b>Pressure above 1-1/2 PSI (7 kPa) at standstill will prevent transmission from downshifting.</b> |

70125

## Hydraulic Pressure Test Diagnosis

| Condition   | Indication  |
|---|---|
| Line pressure OK during any one test                              | Pump and regulator valve OK   |
| Line pressure OK in R but low in D, 2, 1                          | Leakage in rear clutch area (servo, clutch seals, governor support seal rings)  |
| Pressure OK in 1, 2 but low in D3 and R                           | Leakage in front clutch area (servo, clutch seals, retainer bore, pump seal rings)  |
| Pressure OK in 2 but low in R and 1                               | Leakage in rear servo   |
| Front servo pressure in 2   | Leakage in servo; broken servo ring or cracked servo piston   |
| Pressure low in all positions                                     | Clogged filter, stuck pressure regulator valve, worn or defective pump  |
| Governor pressure high at idle (over 0 to 1-1/2 psi)              | Governor valve sticking open  |
| Governor pressure zero or below specifications at all mph figures | Governor valve sticking in closed position  |
| Lubrication pressure low at all throttle positions                | Clogged oil cooler or lines, seal rings leaking, output shaft plugged with debris, worn bushings in pump or clutch retainer |

70126

Lockup Torque Converter Service Diagnosis

| Condition                                    | Possible Cause   | Correction  |
|--|--|---|
| NO LOCKUP                                    | (1) Faulty oil pump.<br>(2) Sticking governor valve.<br>(3) Valve body malfunction.<br>(a) Stuck switch valve.<br>(b) Stuck lockup valve.<br>(c) Stuck fail-safe valve.<br>(4) Faulty torque converter.<br>(5) Failed locking clutch.<br>(6) Leaking turbine hub seal.<br>(7) Faulty input shaft or seal ring. | (1) Replace oil pump.<br>(2) Repair or replace as necessary.<br>(3) Repair or replace valve body or its internal components as necessary.<br>(4) Replace torque converter.<br>(5) Replace torque converter.<br>(6) Replace torque converter.<br>(7) Repair or replace as necessary. |
| WILL NOT UNLOCK                              | (1) Sticking governor valve.<br>(2) Valve body malfunction.<br>(a) Stuck switch valve.<br>(b) Stuck lockup valve.<br>(c) Stuck fail-safe valve.  | (1) Repair or replace as necessary.<br>(2) Repair or replace valve body or its internal components as necessary.  |
| STAYS LOCKED UP AT TOO LOW A SPEED IN DIRECT | (1) Sticking governor valve.<br>(2) Valve body malfunction.<br>(a) Stuck switch valve.<br>(b) Stuck lockup valve.<br>(c) Stuck fail-safe valve.  | (1) Repair or replace as necessary.<br>(2) Repair or replace valve body or its internal components as necessary.  |
| LOCKS UP OR DRAGS IN LOW OR SECOND           | (1) Faulty oil pump.<br>(2) Valve body malfunction.<br>(a) Stuck switch valve.<br>(b) Stuck fail-safe valve.   | (1) Replace oil pump.<br>(2) Repair or replace valve body or its internal components as necessary.  |
| SLUGGISH OR STALLS IN REVERSE                | (1) Faulty oil pump.<br>(2) Plugged cooler, cooler lines or fittings.<br>(3) Valve body malfunction.<br>(a) Stuck switch valve.<br>(b) Faulty input shaft or seal ring.  | (1) Replace oil pump as necessary.<br>(2) Flush or replace cooler and flush lines and fittings.<br>(3) Repair or replace valve body or its internal components as necessary.  |

## Lockup Torque Converter Service Diagnosis (cont.)

| Condition   | Possible Cause  | Correction   |
|---|---|--|
| LOUD CHATTER DURING LOCKUP ENGAGEMENT (COLD)              | (1) Faulty torque converter.<br>(2) Failed locking clutch.<br>(3) Leaking turbine hub seal.   | (1) Replace torque converter.<br>(2) Replace torque converter.<br>(3) Replace torque converter.  |
| VIBRATION OR SHUDDER DURING LOCKUP ENGAGEMENT             | (1) Faulty oil pump.<br>(2) Valve body malfunction.<br>(3) Faulty torque converter.<br>(4) Engine needs tune-up.  | (1) Repair or replace oil pump as necessary.<br>(2) Repair or replace valve body or its internal components as necessary.<br>(3) Replace torque converter.<br>(4) Tune engine.   |
| VIBRATION AFTER LOCKUP ENGAGEMENT                         | (1) Faulty torque converter.<br>(2) Exhaust system strikes underbody.<br>(3) Engine needs tune-up.<br>(4) Throttle linkage misadjusted.   | (1) Replace torque converter.<br>(2) Align exhaust system.<br>(3) Tune engine.<br>(4) Adjust throttle linkage.   |
| VIBRATION WHEN REVVED IN NEUTRAL                          | (1) Torque converter out of balance.  | (1) Replace torque converter.  |
| OVERHEATING: OIL BLOWS OUT OF DIP STICK TUBE OR PUMP SEAL | (1) Plugged cooler, cooler lines or fittings.<br>(2) Stuck switch valve.  | (1) Flush or replace cooler and flush lines and fittings.<br>(2) Repair switch valve in valve body or replace valve body.  |
| SHUDDER AFTER LOCKUP ENGAGEMENT                           | (1) Faulty oil pump.<br>(2) Plugged cooler, cooler lines or fittings.<br>(3) Valve body malfunction.<br>(4) Faulty torque converter.<br>(5) Fail locking clutch.<br>(6) Exhaust system strikes underbody.<br>(7) Engine needs tune-up.<br>(8) Throttle linkage misadjusted. | (1) Replace oil pump.<br>(2) Flush or replace cooler and flush lines and fittings.<br>(3) Repair or replace valve body or its internal components as necessary.<br>(4) Replace torque converter.<br>(5) Replace torque converter.<br>(6) Align exhaust system.<br>(7) Tune engine.<br>(8) Adjust throttle linkage. |



**Torque Specifications**

Service Set-To Torques should be used when assembling components. Service In-Use Recheck Torques should be used for checking a pre-torqued item.

|  | USA (in-lbs)          |                               | Metric (N·m)          |                               |
|--|-----------------------|-------------------------------|-----------------------|-------------------------------|
|  | Service Set-To Torque | Service In-Use Recheck Torque | Service Set-To Torque | Service In-Use Recheck Torque |
| Cooler Line Fitting .....  | 160 in-lb             | 120-200 in-lb                 | 18                    | 14-23                         |
| Cooler Line Nut .....  | 150 in-lb             | 130-180 in-lb                 | 17                    | 15-20                         |
| Converter Drive Plate to Crankshaft Bolts - 4 Cylinder .....       | 58                    | 50-56                         | 79                    | 68-89                         |
| Converter Drive Plate to Crankshaft Bolts - 6 Cylinder .....       | 105                   | 95-120                        | 142                   | 129-163                       |
| Converter Drive Plate to Torque Converter Bolts - 4 Cylinder ..... | 40                    | 35-40                         | 54                    | 47-54                         |
| Converter Drive Plate to Torque Converter Bolts - 6 Cylinder ..... | 26                    | 22-30                         | 35                    | 30-44                         |
| Adapter Housing-to-Transmission Case Bolt .....                    | 24                    | —                             | 33                    | —                             |
| Governor Body Bolt .....   | 100 in-lb             | —                             | 11                    | —                             |
| Front Band Adjusting Screw Locknut .....                           | 35                    | —                             | 47                    | —                             |
| Kickdown Lever Shaft Plug .....                                    | 150 in-lb             | —                             | 17                    | —                             |
| Rear Band Adjusting Screw Locknut .....                            | 35                    | —                             | 47                    | —                             |
| Neutral Starter Switch .....                                       | 24                    | —                             | 33                    | —                             |
| Oil Filler Tube Bracket Bolt .....                                 | 150 in-lb             | —                             | 17                    | —                             |
| Oil Pan Bolt .....   | 150 in-lb             | 9-13                          | 17                    | 12-18                         |
| Oil Pump Housing-to-Transmission Case Bolt .....                   | 175 in-lb             | —                             | 20                    | —                             |
| Output Shaft Support Bolt .....                                    | 150 in-lb             | —                             | 17                    | —                             |
| Overrunning Clutch Cam Setscrew .....                              | 40 in-lb              | —                             | 4                     | —                             |
| Pressure Test Port Plug .....                                      | 110 in-lb             | —                             | 12                    | —                             |
| Reaction Shaft Support to Oil Pump Bolt .....                      | 160 in-lb             | —                             | 18                    | —                             |
| Transmission-to-Engine Bolt .....                                  | 28                    | 22-30                         | 38                    | 30-41                         |
| Valve Body Screw .....   | 35 in-lb              | —                             | 4                     | —                             |
| Valve Body-to-Transmission Case Screw .....                        | 100 in-lb             | —                             | 11                    | —                             |

All Torque values given in inch-pounds and Newton-meters with dry fits unless otherwise specified.

70121

**Fluid Level**

Fill to "Add One Pint" mark on dipstick. Use AMC, Dexron, or equivalent Automatic transmission fluid.

**NOTE:** Check fluid level with gearshift selector lever in N (neutral) position and with fluid at normal operating temperature.

70129

**Fluid Capacity and Gear Ratios**

|  |   |
|--|---|
| Fluid Capacity — Transmission and Torque Converter |   |
| 904-999 .....                                      | 17 pints (8 liters)                         |
| 727 .....  | 19 pints (9 liters)                         |
| Cooling Method .....                               | Water-Heat Exchanger in Radiator Lower Tank |
| Fluid Pressure and Lubrication — All Models .....  |   |
| Rotor-Type Pump                                    |   |
| Gear Ratios — 999-727                              |   |
| First .....  | 2.45:1                                      |
| Second .....                                       | 1.45:1                                      |
| Third .....  | 1.00:1                                      |
| Reverse .....                                      | 2.20:1                                      |
| Gear Ratios — 904                                  |   |
| First .....  | 2.74:1                                      |
| Second .....                                       | 1.55:1                                      |
| Third .....  | 1.00:1                                      |
| Reverse .....                                      | 2.20:1                                      |

30069

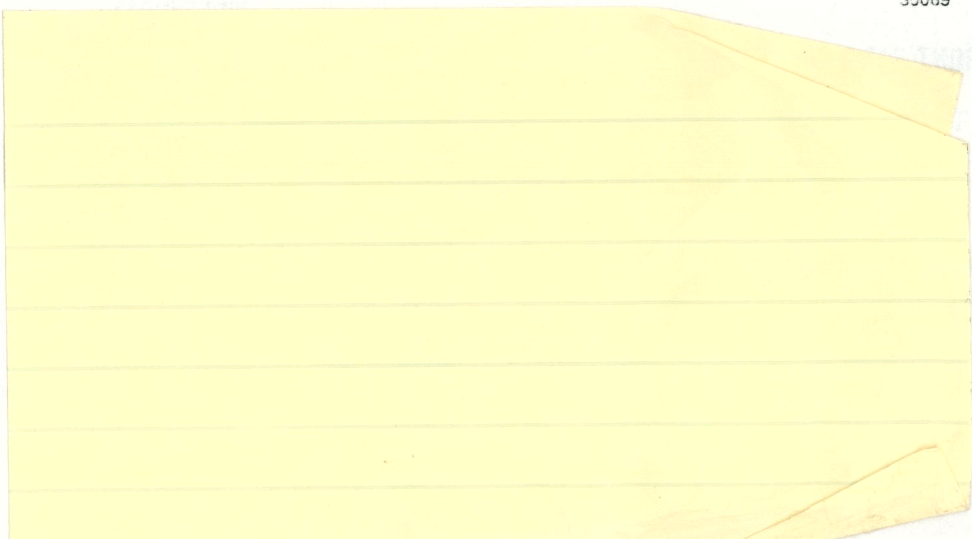

# IN-VEHICLE SERVICE AND ADJUSTMENT

|                                      | Page  |                                 | Page  |
|--------------------------------------|-------|---------------------------------|-------|
| Fluid Level Check                    | 2C-33 | Park Lock Component Replacement | 2C-30 |
| Front Band Adjustment                | 2C-26 | Rear Band Adjustment            | 2C-27 |
| Gearshift Linkage Adjustment         | 2C-26 | Specifications                  | 2C-33 |
| Governor Valve Service               | 2C-29 | Throttle Linkage Adjustment     | 2C-31 |
| Neutral Start and Backup Lamp Switch | 2C-30 | Valve Body Service              | 2C-27 |
| Oil Filter Replacement               | 2C-27 |                                 |       |

## GEARSHIFT LINKAGE ADJUSTMENT

- (1) Raise vehicle.
- (2) Loosen shift rod trunnion jamnuts.
- (3) Remove lockpin retaining shift rod trunnion to bell crank and disengage trunnion and shift rod at bell crank.
- (4) Place gearshift lever in Park position and lock steering column.
- (5) Move valve body manual lever rearward into Park detent. Be sure lever is moved rearward as far as possible. Park detent is last rearward detent.
- (6) Check for positive engagement of park lock by attempting to rotate propeller shaft. Shaft will not rotate if park lock pawl is fully engaged in park gear.
- (7) Adjust shift rod trunnion to obtain free pin fit in bell crank arm and tighten trunnion jamnuts. Prevent shift rod from turning while tightening jamnuts.

**NOTE:** Gearshift linkage lash must be eliminated in order to obtain a proper adjustment. Eliminate lash by pulling downward on the shift rod and pressing upward on the outer bell crank.

- (8) Move gearshift lever to Park and Neutral positions and check engine starting. Engine should start in these positions only. Engine must not start in any gear position other than Park or Neutral. If engine does not start or starts in R, D, 2, or 1, adjustment is incorrect or neutral switch is defective.

- (9) Check steering lock for ease of operation.
- (10) Lower vehicle.

## FRONT BAND ADJUSTMENT

The front band adjusting screw is located on the left side of the transmission case just above the manual valve and throttle control levers (fig. 2C-21).

### Adjustment Procedure

- (1) Raise vehicle.
- (2) Loosen adjusting screw locknut and back off locknut five turns.

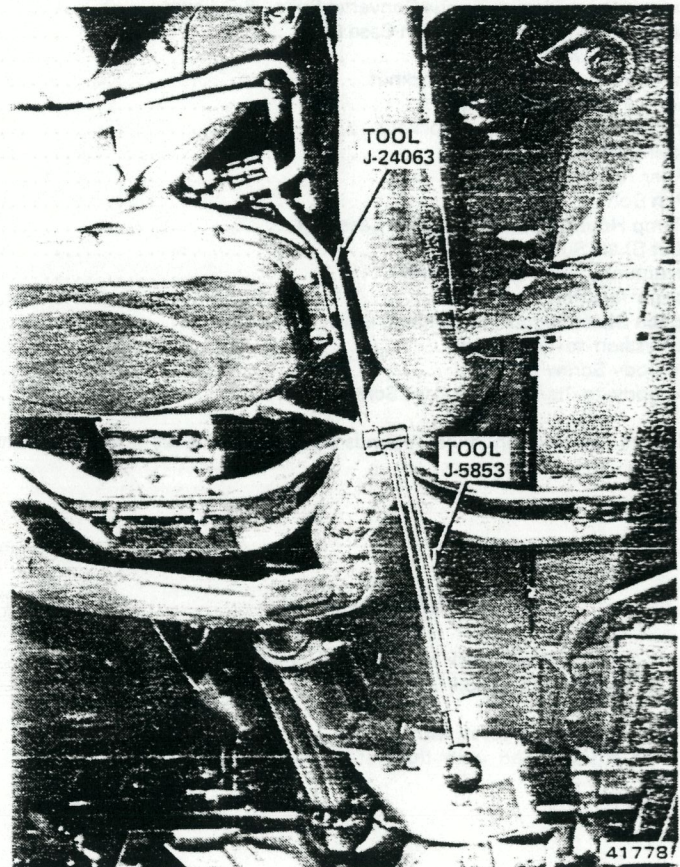

Fig. 2C-21 Front Band Adjustment

- (3) Check adjusting screw rotation. Screw must turn freely in case. Lubricate adjusting screw threads if screw binds.

- (4) Tighten adjusting screw to 36 inch-pounds (4 N•m) torque using Torque Wrench J-5853, Adapter Tool J-24063 and 5/16 square socket (fig. 2C-21).

**CAUTION:** If Adapter Tool J-24063 is not used, the band adjusting screw must be tightened to 72 inch-pounds (8 N•m) torque.

- (5) Back off adjusting screw two turns.
- (6) Tighten adjuster screw locknut to 35 foot-pounds (47 N•m) torque. Do not allow adjuster screw to rotate when tightening locknut.
- (7) Lower vehicle.

## REAR BAND ADJUSTMENT

The rear band adjustment is an internal adjustment. The transmission oil pan must be removed to gain access to the band adjusting screw (fig. 2C-22).

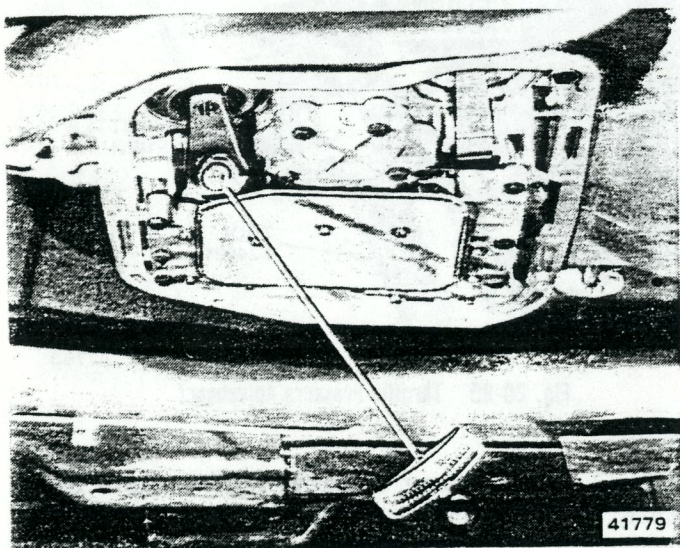

Fig. 2C-22 Rear Band Adjustment

### Adjustment Procedure

- (1) Raise vehicle.
- (2) Remove oil pan and drain fluid.
- (3) Inspect fluid and filter for heavy accumulation of friction material or metal particles which indicate worn or damaged parts. However, a very light accumulation of this material is normal.
- (4) Adjust band as follows (fig. 2C-22):
  - (a) Remove adjusting screw locknut.
  - (b) Tighten adjusting screw to 41 inch-pounds (5 N•m) using torque wrench and 1/4 hex-head socket wrench.
  - (c) On Model 999, back off adjusting screw four turns.
  - (d) On Model 727, back off adjusting screw two turns.
  - (e) Hold adjusting screw in position and install locknut. Tighten locknut to 35 foot-pounds (47 N•m) torque.
- (5) Install oil pan and replacement pan gasket. Tighten oil pan bolts to 150 inch-pounds (17 N•m) torque.
- (6) Lower vehicle.
- (7) Fill transmission with Jeep, Dexron, or equivalent automatic transmission fluid. Refer to Fluid Level and Condition for refill procedure.

## OIL FILTER REPLACEMENT

- (1) Raise vehicle.
- (2) Remove oil pan and drain fluid.

(3) Inspect fluid and filter for heavy accumulation of friction material or metal particles which indicate worn or damaged parts.

(4) Remove three screws attaching filter to valve body and remove filter.

(5) Install replacement filter and tighten filter attaching screws to 35 inch-pounds (4 N•m) torque.

(6) Clean and install oil pan and replacement pan gasket. Tighten pan bolts to 150 inch-pounds (17 N•m) torque.

(7) Lower vehicle

(8) Fill transmission with Jeep, Dexron, or equivalent automatic transmission fluid. Refer to Fluid Level and Condition for refill procedure.

## VALVE BODY SERVICE

### Removal

- (1) Raise vehicle.
- (2) Remove oil pan and drain fluid.
- (3) Loosen clamp bolts and remove throttle and manual valve control levers from valve body shafts.
- (4) Remove neutral switch from case.
- (5) Remove valve body attaching screws (fig. 2C-23).
- (6) Lower valve body, pull valve body forward to disengage park lock rod, and remove valve body.

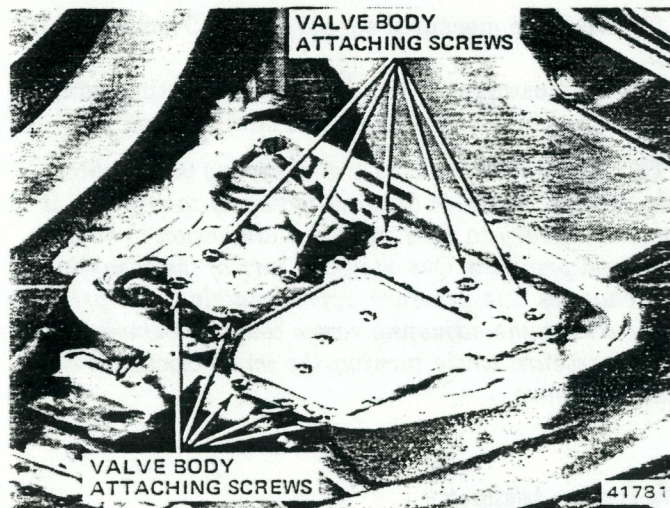

Fig. 2C-23 Valve Body Attaching Screw Location

**NOTE:** It may be necessary to rotate the output shaft before the park lock rod will clear the park sprag.

- (7) Remove oil filter.
- (8) Mount valve body on Support Stand J-24043.
- (9) Refer to Out-of-Vehicle Service and Overhaul section for valve body service procedures.

### Valve Body Hydraulic Control Pressure Adjustments

There are two hydraulic control pressure adjustments that can be performed on the valve body, they are: Line Pressure and Throttle Pressure adjustment.

Because line and throttle pressure are interdependent (each affects shift quality and timing), both adjustments must be performed properly and in the correct sequence which is; line pressure adjustment first—throttle pressure adjustment last.

### Line Pressure Adjustment

(1) Measure distance from valve body to inner edge of adjusting screw using accurate steel scale (fig. 2C-24).

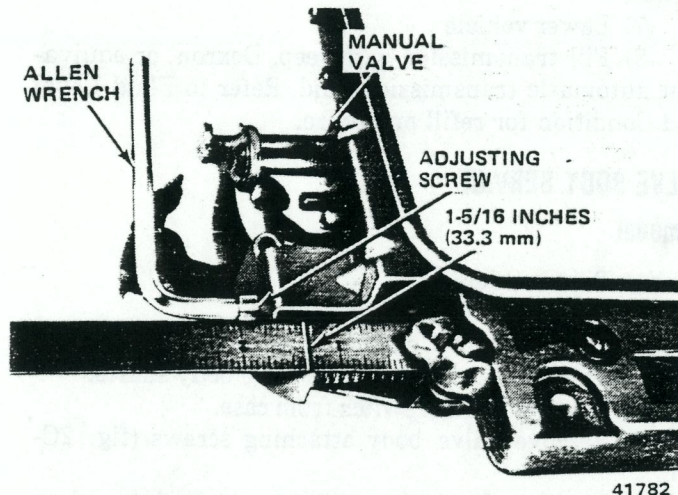

Fig. 2C-24 Line Pressure Adjustment

(2) Distance measured should be 1-5/16 inches (33.4 mm).

(3) If adjustment is required, turn adjusting screw in or out to obtain 1-5/16 inch (33.4 mm) setting.

**NOTE:** The 1-5/16 inch (33.4 mm) setting is an approximate setting. Because of manufacturing tolerances, it may be necessary to vary from this dimension to obtain the desired pressure. One complete turn of the adjusting screw changes line pressure approximately 1-2/3 psi (9 kPa). Turning the adjusting screw counterclockwise increases pressure while turning the screw clockwise decreases pressure.

### Throttle Pressure Adjustment

(1) Insert Gauge Tool J-24031 between throttle lever cam and kickdown valve (fig. 2C-25).

(2) Push gauge tool inward to compress kickdown valve against spring and to bottom throttle valve in valve body.

(3) Maintain pressure against kickdown valve spring and turn throttle lever stop screw until screw head touches throttle lever tang and throttle lever cam touches gauge tool.

**NOTE:** The kickdown valve spring must be fully compressed and the kickdown valve completely bottomed in the valve body to obtain a correct adjustment.

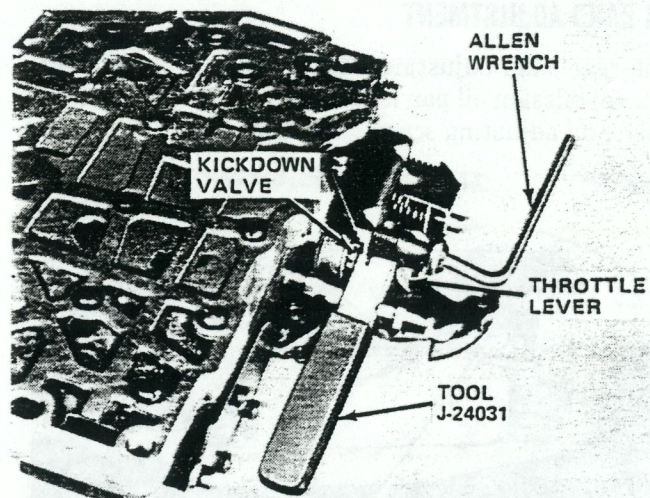

Fig. 2C-25 Throttle Pressure Adjustment

### Installation

(1) Clean all mating surfaces. Be sure burrs are removed from transmission case and valve body steel plate surfaces.

(2) Position accumulator spring on valve body.

(3) Insert park lock rod through opening in rear of case.

(4) Position knob on end of lock rod against reaction plug in sprag and exert rearward pressure on rod to move rod past sprag. Rotate output shaft, if necessary.

(5) Align and install valve body. Install attaching screws finger-tight only.

(6) Install neutral switch.

(7) Move manual valve (in valve body) to neutral position. Align valve body as necessary to align neutral finger of manual lever with neutral switch plunger.

(8) Tighten valve body attaching screws alternately and evenly to 100 inch-pounds (11 N•m) torque.

(9) Install oil filter. Tighten attaching screws to 35 inch-pounds (4 N•m) torque.

(10) Install manual and throttle valve control levers and tighten clamp bolts. Check both shafts for binding after tightening bolts.

(11) Install oil pan and replacement gasket. Tighten oil pan bolts to 150 inch-pounds (17 N•m) torque.

(12) Lower vehicle.

(13) Fill transmission with Jeep, Dexron, or equivalent automatic transmission fluid. Refer to Fluid Level and Condition for refill procedure.

(14) Adjust gearshift and throttle linkage.

### Front and Rear Servos

The front and rear servos may be removed, reconditioned and installed with the transmission in the vehicle.

For removal, inspection and installation procedures, refer to Out-Of-Vehicle Service and Overhaul section.

## GOVERNOR VALVE SERVICE

### Removal

- (1) Raise vehicle.
- (2) Mark propeller shaft yokes for assembly alignment reference.
- (3) Disconnect front-rear propeller shafts at transfer case.
- (4) Disconnect speedometer cable at transfer case.
- (5) Place support stand under transmission converter housing.
- (6) Remove rear crossmember.
- (7) Disconnect parking brake cable at equalizer and disconnect exhaust pipe support brackets, if necessary.
- (8) Remove bolts attaching transfer case to transmission adapter housing and remove transfer case.
- (9) Remove bolts attaching adapter housing to transmission and remove adapter housing.
- (10) Rotate transmission output shaft until governor weight faces downward (fig. 2C-26).

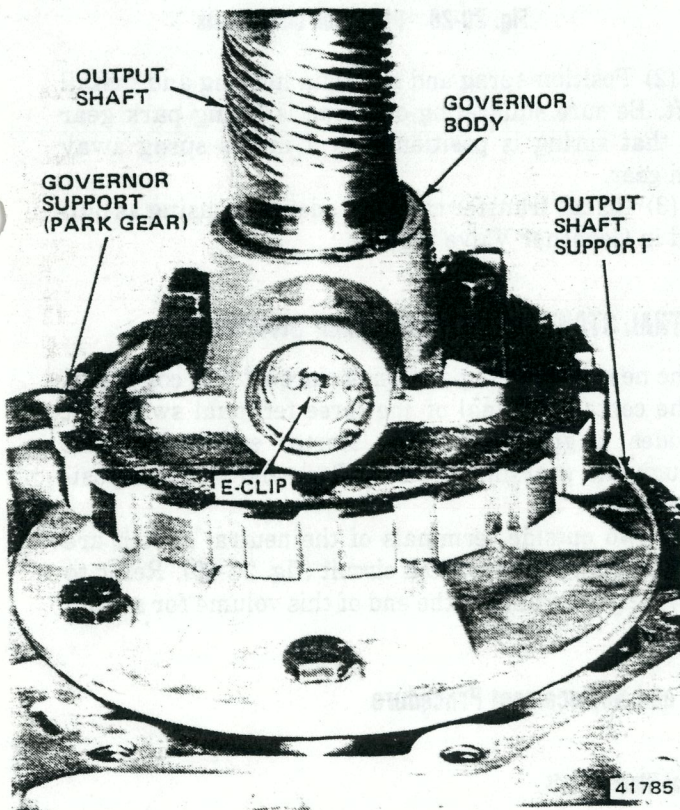

Fig. 2C-26 Governor Weight E-Clip Location

- (11) Remove E-clip from weight end of governor valve shaft (fig. 2C-26).
- (12) Remove governor valve and shaft from governor body (fig. 2C-27).
- (13) Remove snap ring that retains governor body-park gear assembly on output shaft.
- (14) Remove governor body-park gear assembly from output shaft.

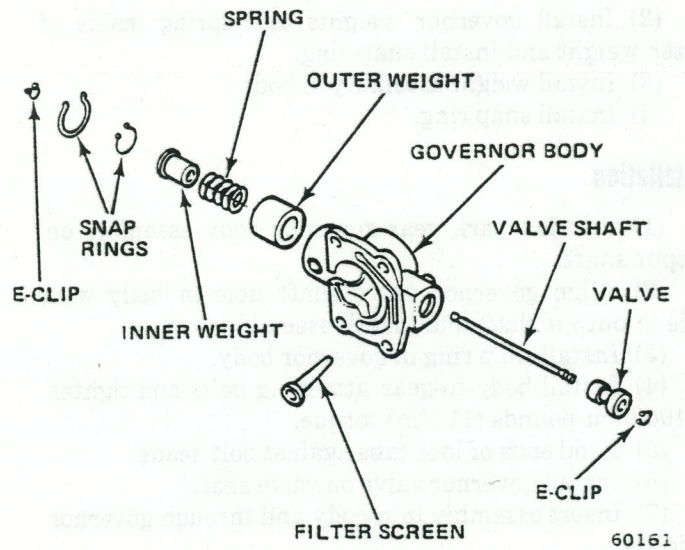

Fig. 2C-27 Governor Valve Assembly

### Disassembly

- (1) Remove large snap ring from weight end of governor body (fig. 2C-27).
- (2) Remove weight assembly.
- (3) Remove snap ring from governor weight assembly.
- (4) Separate inner weight, spring, and outer weight. Identify spring with tag.
- (5) If park gear or governor body is to be replaced, straighten lock tabs and remove bolts attaching body to gear.
- (6) Remove governor filter.

### Cleaning and Inspection

Thoroughly clean all governor parts in a suitable cleaning solution but do not use any type of caustic cleaning solution.

The weights and valves should fall freely in their bores when clean and dry. Rough surfaces and burrs may be polished using crocus cloth.

Inspect the governor weight spring for distortion. Replace the spring, if damaged.

Clean the filter in solvent and dry it with compressed air. Replace the filter, if damaged.

Inspect the park gear for chipped or worn gear teeth or damaged ring grooves. Replace the gear, if damaged.

Check the bolt torque on the output shaft support attaching bolts. If loose, cross-leakage and loss of governor pressure can occur.

### Assembly

(1) If governor body was separated from park gear, install filter, assemble body and support, and install attaching bolts finger-tight.

**NOTE:** Do not tighten the bolts to specified torque until the assembly is installed on the output shaft.

- (2) Install governor weights and spring inside of outer weight and install snap ring.
- (3) Install weight assembly in body.
- (4) Install snap ring.

### Installation

- (1) Position park gear-governor body assembly on output shaft.
- (2) Align governor valve shaft hole in body with hole in output shaft and install assembly.
- (3) Install snap ring in governor body.
- (4) Install body-to-gear attaching bolts and tighten to 100 inch-pounds (11 Nm) torque.
- (5) Bend ends of lock tabs against bolt heads.
- (6) Install governor valve on valve shaft.
- (7) Insert assembly into body and through governor weights.
- (8) Install retaining E-clip.
- (9) Install and tighten adapter housing bolts to 24 foot-pounds (32 N•m) torque.
- (10) Install transfer case.
- (11) Install rear crossmember.
- (12) Connect speedometer cable.
- (13) Connect exhaust support brackets and brake cable, if removed.
- (14) Connect propeller shafts. Align assembly reference marks and tighten clamp bolts to 14 foot-pounds (19 N•m) torque.
- (15) Adjust gearshift and throttle linkage.
- (16) Lower vehicle.
- (17) Fill transmission with Jeep, Dexron, or equivalent transmission fluid. Refer to Fluid Level and Condition for refill procedure.

## PARK LOCK COMPONENT REPLACEMENT

### Disassembly

- (1) Remove adapter housing and transfer case as outlined in Governor Valve Service.
- (2) Slide shaft out of housing and remove park sprag and spring (fig. 2C-25).
- (3) Remove snap ring and slide reaction plug and pin assembly out of housing.
- (4) To replace park lock control rod, refer to Valve Body in Out-of-Vehicle Service and Overhaul section.

### Inspection

Check the sprag shaft for scores and for free movement in the housing and sprag. Check the sprag and control rod springs for loss of tension or distortion. Check the square lug on the sprag for broken edges. Check the lugs on the governor support (park gear) for broken edges. Check the knob on the end of the control rod for nicks, burrs, and free turning.

### Assembly

- (1) Install reaction plug and pin assembly in housing and install snap ring (fig. 2C-28).

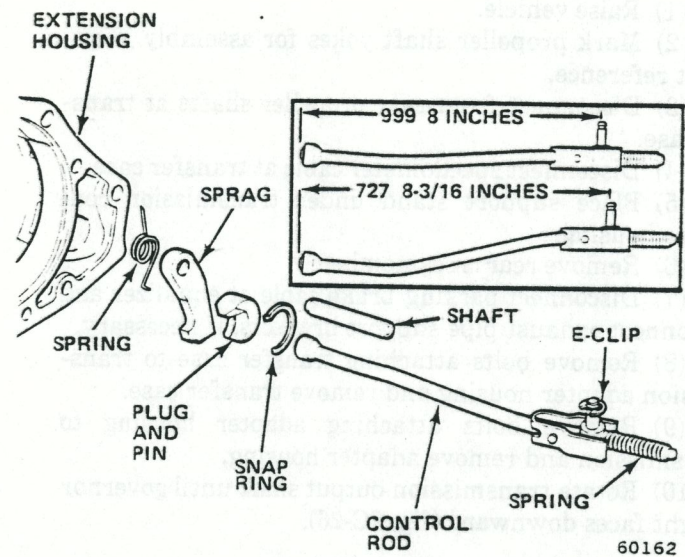

Fig. 2C-28 Park Lock Components

- (2) Position sprag and spring in housing and install shaft. Be sure square lug on sprag is facing park gear and that spring is positioned so it moves sprag away from gear.
- (3) Install transfer case and adapter housing as outlined in Governor Valve Service.

## NEUTRAL START AND BACKUP LAMP SWITCH

The neutral starting section of the switch is contained in the center terminal of the three terminal switch. It provides a ground for the starter solenoid circuit through the gearshift lever in Park and Neutral positions only.

The two outside terminals of the neutral switch are for the backup lamp switch circuit (fig. 2C-29). Refer to the wiring diagrams at the end of this volume for switch circuitry.

### Test and Replacement Procedure

#### Neutral Start Circuit

- (1) Remove wiring connector from switch and test for continuity between center terminal pin and transmission case. Continuity should exist only when transmission is in Park or Neutral.
- (2) If tests show switch may be defective, check gearshift linkage adjustment before replacing switch.
- (3) Remove switch from transmission. Allow transmission fluid to drain into container.
- (4) Move gearshift lever to Park and Neutral positions. Inspect switch operating lever fingers and manual

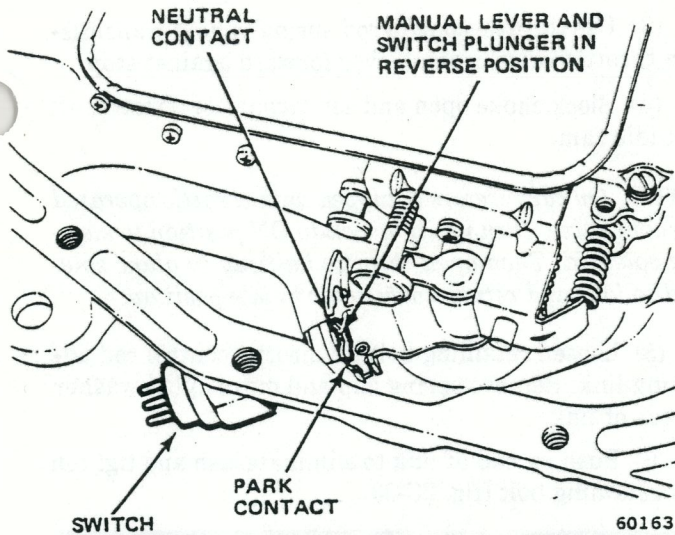

**Fig. 2C-29 Neutral Start and Backup Lamp Switch**

lever and shaft for proper alignment with switch opening in case.

(5) Install switch and switch seal in transmission case. Tighten switch to 24 foot-pounds (33 N•m) torque.

(6) Test switch continuity.

(7) Correct transmission fluid level as required. Refer to Fluid Level and Condition for refill procedure.

#### Backup Lamp Circuit

(1) Remove wiring connector from switch and test for continuity between two outside pins.

(2) Continuity should exist when transmission is in reverse only.

(3) Continuity should not exist from either pin to transmission case in reverse.

(4) Replace switch if tests prove switch is defective.

### THROTTLE CABLE AND LINKAGE ADJUSTMENT

#### Throttle Cable Adjustment—Four-Cylinder Engine

(1) Remove air cleaner.

(2) Remove spark plug wire separator from throttle cable bracket and move separator and wires aside.

(3) Raise vehicle.

(4) Hold throttle control lever rearward against its stop. Use spare spring to hold lever. Hook one end of spring to lever and hook opposite end of spring to convenient attachment point.

(5) Lower vehicle.

(6) Block choke open and set carburetor linkage completely off fast idle cam.

(7) On four-cylinder vehicles without air conditioning, turn ignition key to On position to energize throttle stop solenoid.

(8) Unlock throttle control cable by releasing T-shaped cable adjuster clamp (fig. 2C-30). Release clamp by lifting upward with small screwdriver.

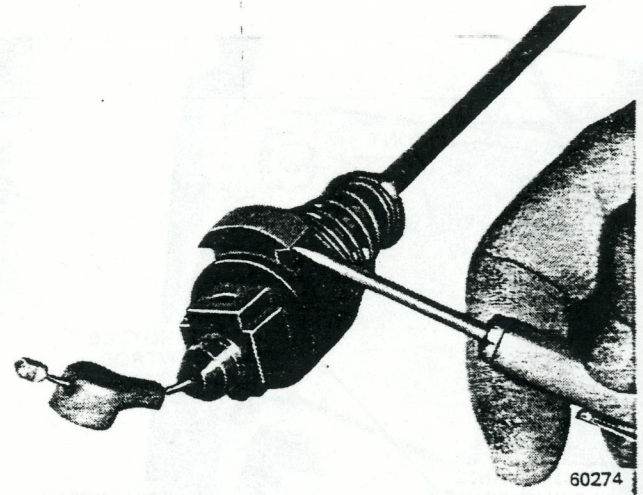

**Fig. 2C-30 Throttle Cable/Linkage Adjustment**

(9) Grasp cable outer sheath and move cable and sheath forward to remove any cable load on throttle cable bell crank.

**NOTE:** The bell crank is part of the carburetor throttle linkage.

(10) Adjust cable by moving cable and sheath rearward until there is zero lash between plastic cable end and bell crank ball.

(11) When zero lash between cable end and bell crank is achieved, lock cable by pressing T-shaped cable adjuster clamp downward until clamp snaps into place.

(12) Turn ignition off. Install spark plug wires and separator, connect throttle stop solenoid on air conditioned vehicles and install air cleaner.

(13) Raise vehicle. Remove holding spring from transmission throttle control lever and lower vehicle.

(14) Road test vehicle and check transmission operation. Readjust throttle cable, if necessary.

#### Throttle Linkage Adjustment—Six-Cylinder Engine

(1) Disconnect throttle control rod spring at carburetor.

(2) Raise vehicle.

(3) Use throttle control rod spring to hold transmission throttle control lever forward against stop (fig. 2C-31). Hook one end of spring on throttle control lever and other end on throttle linkage bell crank bracket attached to converter housing.

(4) Block choke open and set carburetor throttle off fast idle cam.

**NOTE:** On carburetors equipped with a throttle operated solenoid valve, turn the ignition lock to the ON position to energize the solenoid. Then open the throttle halfway to allow the solenoid to lock and return the carburetor to idle position.

(5) Loosen retaining bolt on throttle control adjusting link. Do not remove spring clip and nylon washer.

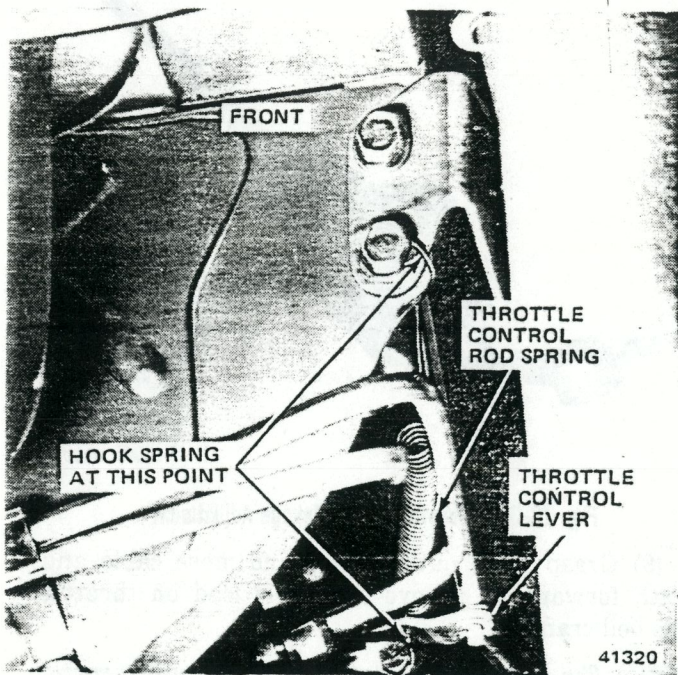

Fig. 2C-31 Installing Throttle Control Lever Spring

(6) Pull on end of link to eliminate lash and tighten link retaining bolt (fig. 2C-32).

(7) Remove throttle control rod spring from linkage and install it on control rod.

(8) Lower vehicle.

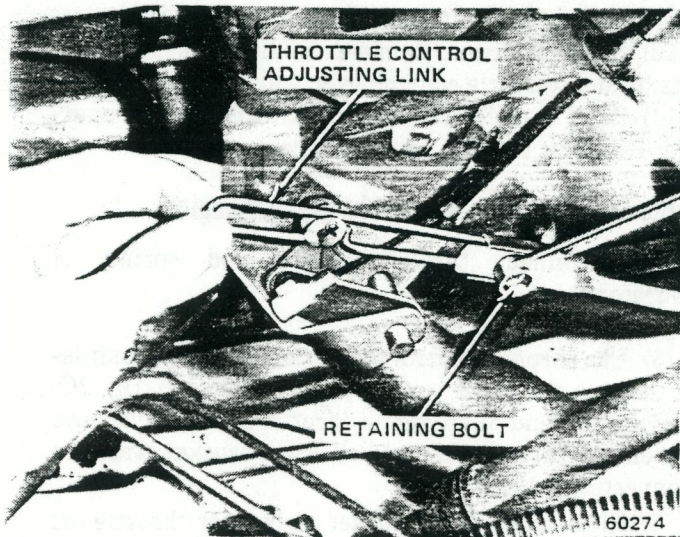

Fig. 2C-32 Tightening Link Retaining Bolt—Six-Cylinder Engine

### Throttle Linkage Adjustment—Eight-Cylinder Engine

(1) Disconnect throttle control rod spring at carburetor.

(2) Raise vehicle.

(3) Use throttle control rod spring to hold transmission throttle valve control lever forward against stop.

(4) Block choke open and set carburetor throttle off fast idle cam.

**NOTE:** On carburetors equipped with throttle operated solenoid valve, turn ignition lock to ON position to energize solenoid. Then open throttle halfway to allow solenoid to lock and return carburetor to idle position.

(5) Loosen retaining bolt on throttle control rod adjusting link. Remove spring clip and move nylon washer to rear of link.

(6) Push on end of link to eliminate lash and tighten link retaining bolt (fig. 2C-33).

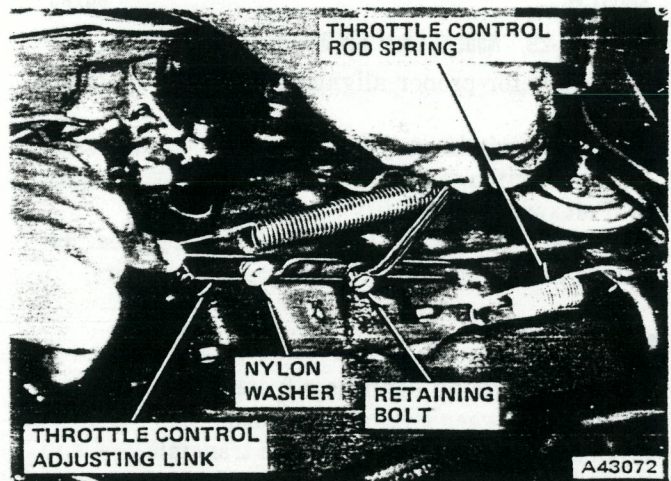

Fig. 2C-33 Tightening Link Retaining Bolt—Eight-Cylinder Engine

(7) Install nylon washer and spring clip (fig. 2C-34).

(8) Remove throttle control rod spring from linkage and install it on rod.

(9) Lower vehicle.

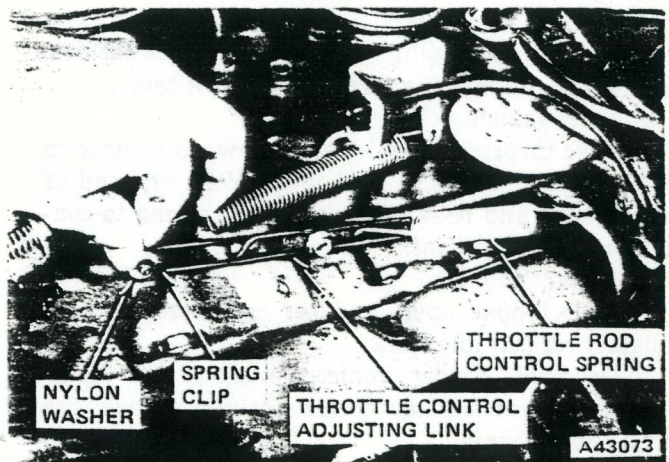

Fig. 2C-34 Installing Nylon Washer and Spring Clip—Eight-Cylinder Engine



**SPECIFICATIONS**

**Band Adjustments**

|                   | 904 | 999 | 727    |
|-------------------|-----|-----|--------|
| Front Band Turns* | 2.5 | 2   | 2- 1/2 |
| Rear Band Turns*  | 7   | 4   | 2      |

NOTE: \* 904 backed off from 41 in-lbs (5 N.m); 999/727 models backed off from 72 in-lb (8 N.m).

70130

**Fluid Levels**

Fill to "Add One Pint" mark on dipstick. Use Jeep, Dexron, or equivalent Automatic transmission fluid.

NOTE: Check fluid level with gearshift selector lever in N (neutral) position and with fluid at normal operating temperature.

70129

**Torque Specifications**

Service Set-To Torques should be used when assembling components. Service In-Use Recheck Torques should be used for checking a pre-torqued item.

|  | USA (in-lbs)          |                               | Metric (N·m)          |                               |
|--|-----------------------|-------------------------------|-----------------------|-------------------------------|
|  | Service Set-To Torque | Service In-Use Recheck Torque | Service Set-To Torque | Service In-Use Recheck Torque |
| Cooler Line Fitting  | 160 in-lb             | 120-200 in-lb                 | 18                    | 14-23                         |
| Cooler Line Nut  | 150 in-lb             | 130-180 in-lb                 | 17                    | 15-20                         |
| Converter Drive Plate to Crankshaft Bolts - 4 Cylinder       | 58                    | 50-56                         | 79                    | 68-89                         |
| Converter Drive Plate to Crankshaft Bolts - 6 Cylinder       | 105                   | 95-120                        | 142                   | 129-163                       |
| Converter Drive Plate to Torque Converter Bolts - 4 Cylinder | 40                    | 35-40                         | 54                    | 47-54                         |
| Converter Drive Plate to Torque Converter Bolts - 6 Cylinder | 26                    | 22-30                         | 35                    | 30-44                         |
| Adapter Housing-to-Transmission Case Bolt                    | 24                    | —                             | 33                    | —                             |
| Governor Body Bolt   | 100 in-lb             | —                             | 11                    | —                             |
| Front Band Adjusting Screw Locknut                           | 35                    | —                             | 47                    | —                             |
| Kickdown Lever Shaft Plug                                    | 150 in-lb             | —                             | 17                    | —                             |
| Rear Band Adjusting Screw Locknut                            | 35                    | —                             | 47                    | —                             |
| Neutral Starter Switch                                       | 24                    | —                             | 33                    | —                             |
| Oil Filler Tube Bracket Bolt                                 | 150 in-lb             | —                             | 17                    | —                             |
| Oil Pan Bolt   | 150 in-lb             | 9-13                          | 17                    | 12-18                         |
| Oil Pump Housing-to-Transmission Case Bolt                   | 175 in-lb             | —                             | 20                    | —                             |
| Output Shaft Support Bolt                                    | 150 in-lb             | —                             | 17                    | —                             |
| Overrunning Clutch Cam Setscrew                              | 40 in-lb              | —                             | 4                     | —                             |
| Pressure Test Port Plug                                      | 110 in-lb             | —                             | 12                    | —                             |
| Reaction Shaft Support to Oil Pump Bolt                      | 160 in-lb             | —                             | 18                    | —                             |
| Transmission-to-Engine Bolt                                  | 28                    | 22-30                         | 38                    | 30-41                         |
| Valve Body Screw   | 35 in-lb              | —                             | 4                     | —                             |
| Valve Body-to-Transmission Case Screw                        | 100 in-lb             | —                             | 11                    | —                             |

All Torque values given in inch-pounds and Newton-meters with dry fits unless otherwise specified.

70121

**OUT-OF-VEHICLE SERVICE AND OVERHAUL**

|                       | Page  |                           | Page  |
|-----------------------|-------|---------------------------|-------|
| Specifications        | 2C-68 | Transmission Disassembly  | 2C-35 |
| Subassembly Overhaul  | 2C-37 | Transmission Installation | 2C-34 |
| Transmission Assembly | 2C-64 | Transmission Removal      | 2C-33 |

**TRANSMISSION REMOVAL**

- (1) Disconnect fan shroud, if equipped.
- (2) Disconnect transmission fill tube at upper bracket.
- (3) Raise vehicle.
- (4) Remove inspection cover from converter housing.
- (5) Remove transmission fill tube.
- (6) Remove starter.

(7) Mark propeller shafts and axle yokes for assembly alignment reference.

(8) Disconnect propeller shafts at transfer case yokes. Secure shafts to frame rails with wire.

(9) On eight-cylinder vehicles, disconnect exhaust pipes at exhaust manifolds.

(10) Drain transfer case lubricant from Cherokee, Wagoneer and Truck models and disconnect speedometer cable at transfer case.

(11) Disconnect gearshift and throttle linkage.

(12) Disconnect wires at neutral start switch.

(13) Mark converter drive plate and converter for assembly alignment reference.

(14) Remove bolts attaching converter to drive plate. Rotate crankshaft and drive plate using ratchet handle and socket on crankshaft front pulley bolt to gain access to drive plate bolts.

(15) Support transmission-transfer case assembly using transmission jack. Retain transmission on jack with safety chain.

(16) Remove bolts attaching rear crossmember to transmission.

(17) Remove rear crossmember.

(18) Lower transmission slightly and disconnect oil cooler lines at transmission.

(19) Remove bolts attaching transmission to engine.

(20) Move transmission and converter rearward to clear crankshaft.

(21) Hold converter in position and lower transmission assembly until converter housing clears engine.

(22) Remove transfer case from transmission.

(23) If necessary, the following items can now be serviced:

- Torque Converter
- Torque Converter Drive Plate
- Oil Pump Seal (figs. 2C-35 and 2C-36)
- Engine Core Hole Plugs
- Engine Oil Galley Plugs

**CAUTION:** *If the transmission was removed to correct a malfunction that generated sludge or heavy accumulations of metal particles or friction material, the oil cooler and cooler lines must be flushed thoroughly and the torque converter replaced. Do not attempt to flush the converter if it is contaminated. Refer to Diagnosis—Test Procedures in this chapter for procedure for flushing oil cooler and lines.*

## TRANSMISSION INSTALLATION

(1) Install transfer case on transmission.

(2) If torque converter was removed, insert Pump Aligning Tool J-24033 (Models 904/999) or J-24045 (Model 727) in pump rotor until rotor drive lugs engage slots in tool.

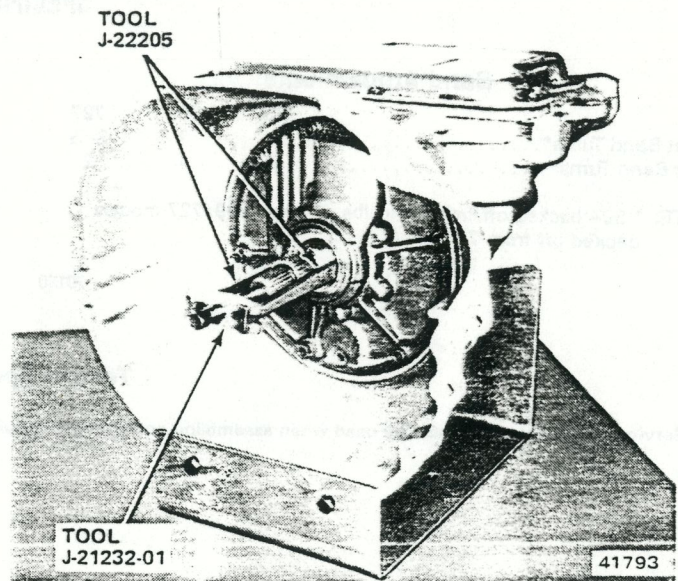

Fig. 2C-35 Oil Pump Seal Removal

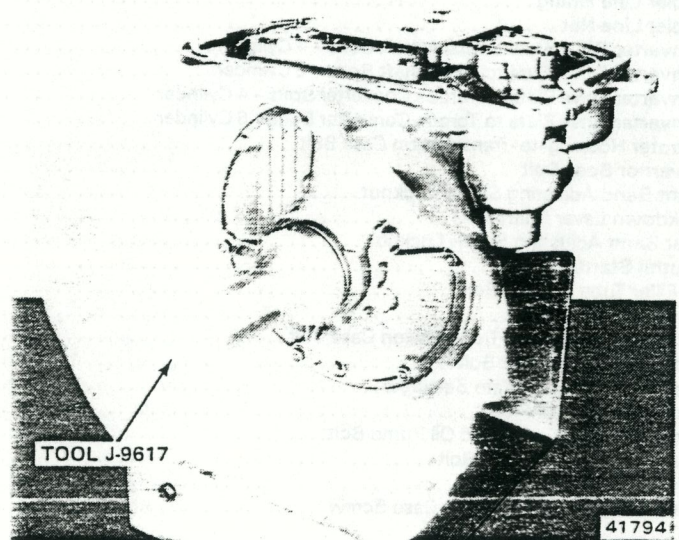

Fig. 2C-36 Oil Pump Seal Installation

(3) Rotate tool until drilled hole in tool is vertical and remove tool.

(4) Rotate converter until pump drive slots in converter hub are vertical and carefully insert converter hub into pump. Be sure drive lugs of pump inner rotor are properly engaged in drive slots of converter hub.

(5) Raise transmission and align converter with drive plate. Refer to assembly alignment marks.

(6) Move transmission forward.

(7) Raise, lower or tilt transmission to align converter housing pilot holes with dowels in engine.

(8) Install two converter housing lower attaching bolts and tighten bolts to pull housing to engine.

(9) Install drive plate-to-converter attaching bolts.

(10) Install remaining converter housing-to-engine attaching bolts. Tighten all bolts to 28 foot-pounds (38 N•m) torque.

- (11) Connect oil cooler lines.
- (12) Install rear support cushion on transmission.
- (13) Raise transmission and install rear cross-member.
- (14) Remove transmission jack.
- (15) Install speedometer cable.
- (16) Install inspection cover.
- (17) Install exhaust pipes and support brackets, if removed.
- (18) Install starter.
- (19) Connect wires to neutral switch.
- (20) Connect gearshift and throttle linkage.
- (21) Install propeller shafts. Refer to alignment marks made during removal.
- (22) Connect front exhaust pipes and catalytic converter support bracket bolts, if removed.
- (23) Fill transfer case to correct level with specified lubricant.
- (24) Lower vehicle.
- (25) Fill transmission to correct level as described in Fluid Level and Condition.
- (26) Adjust gearshift linkage.
- (27) Road test to check transmission operation.

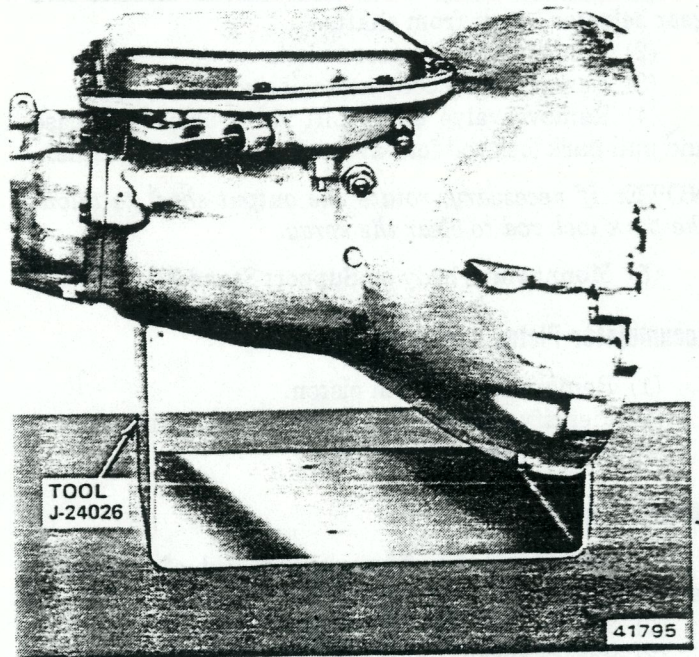

Fig. 2C-37 Transmission Holding Fixture

## TRANSMISSION DISASSEMBLY

**CAUTION:** Cleanliness during disassembly and assembly is necessary to avoid a further malfunction after assembly. Before removing any of the transmission sub-assemblies, plug all openings and thoroughly clean the transmission exterior. Steam cleaning equipment is preferable for this purpose. During disassembly, clean all parts in a suitable solvent and dry each part using compressed air. Do not use cloth or paper towels to dry any parts after cleaning, use compressed air only.

### End Play Measurement

**NOTE:** Measuring end play before disassembly will indicate whether a thrust washer change is required and save time at assembly.

- (1) Mount transmission in Holding Fixture J-24026 (fig. 2C-37).
- (2) Remove one pump attaching bolt and thread Dial Indicator Support Rod J-5864 into bolt hole.
- (3) Attach Dial Indicator J-8001 to rod.
- (4) Position indicator stylus against forward end of input shaft (fig. 2C-38).
- (5) Move input shaft rearward and set dial indicator at zero.
- (6) Pull input shaft forward to obtain end play reading.
- (7) Record reading for assembly reference.
- (8) Remove dial indicator and rod.

### Oil Pan

Remove pan attaching bolts and remove oil pan and gasket. Be sure that any dirt which remained around bolts does not fall into transmission.

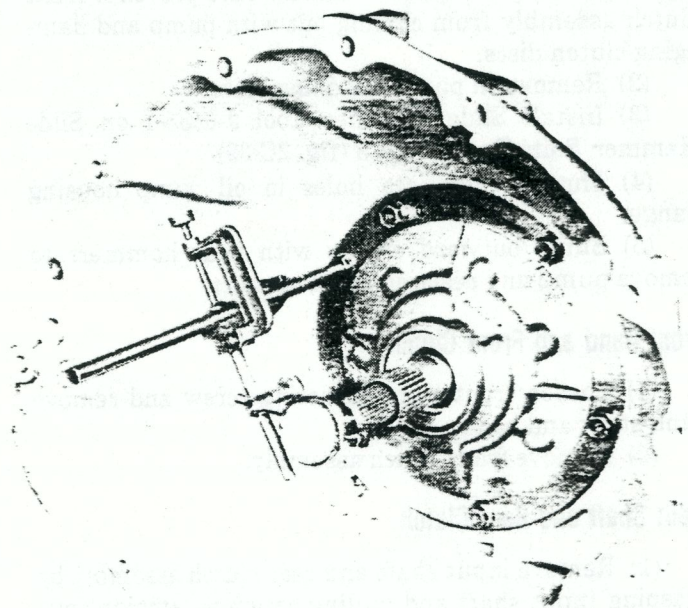

Fig. 2C-38 Measuring End Play

### Valve Body

- (1) Loosen clamp bolts and remove throttle and gear selector levers from shafts.
- (2) Remove neutral start switch.
- (3) Remove valve body attaching screws.
- (4) Remove valve body. Lift valve body from case and pull park lock rod forward out of case at same time.

**NOTE:** If necessary, rotate the output shaft to allow the park lock rod to clear the sprag.

- (5) Mount valve body on Support Stand J-24043.

### Accumulator Piston and Spring

- (1) Remove spring from piston.
- (2) Identify spring with tag for assembly reference.
- (3) Remove piston from case.

### Governor and Support

- (1) Remove E-clip from weight end of governor valve (fig. 2C-26).
- (2) Remove valve and shaft from governor body.
- (3) Rotate output shaft until governor weight faces downward.
- (4) Remove snap ring retaining governor on output shaft.
- (5) Remove governor body and park gear from output shaft.

### Oil Pump and Reaction Shaft Support

- (1) Tighten front band adjusting screw until band is tight around front clutch retainer. This prevents front clutch assembly from coming out with pump and damaging clutch discs.
- (2) Remove oil pump attaching bolts.
- (3) Install Slide Hammer Tool J-6585-1 on Slide Hammer Bolts Tool J-7004-3 (fig. 2C-39).
- (4) Thread bolts into holes in oil pump housing flange.
- (5) Bump outward evenly with slide hammers to remove pump and reaction shaft support.

### Front Band and Front Clutch

- (1) Loosen front band adjusting screw and remove band strut and band.
- (2) Remove front clutch assembly.

### Input Shaft and Rear Clutch

- (1) Remove input shaft and rear clutch assembly by grasping input shaft and pulling assembly straight out of case.

**NOTE:** Do not lose the thrust washer located between the rear end of the input shaft and the front end of the output shaft.

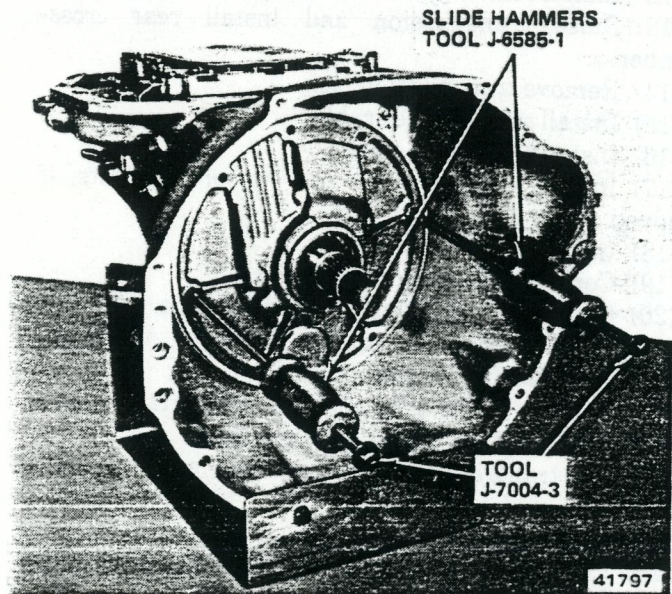

Fig. 2C-39 Oil Pump Removal

### Output Shaft—Planetary Gears

- (1) Carefully remove driving shell and output shaft assembly.

**CAUTION:** Be very careful to protect the machined surfaces on the output shaft during removal.

### Rear Band and Drum

- (1) Pull drum forward and out of case.
- (2) Loosen band adjusting screw.
- (3) Thread 1/4-inch (6 mm) bolt into actuating lever pivot pin.
- (4) Grip bolt with pliers and remove pivot pin.
- (5) Remove lever, linkage and band.

### Overtaking Clutch

Carefully remove clutch hub, rollers, springs and store parts where they will not be lost or damaged.

### Front Servo

- (1) Remove front servo pressure port plug.
- (2) Compress servo piston rod guide until it bottoms in case bore.
- (3) Insert No. 2 Phillips screwdriver into pressure port (fig. 2C-40).
- (4) Slowly release rod guide against screwdriver (fig. 2C-40).
- (5) Remove servo retaining snap ring.
- (6) Compress rod guide and remove screwdriver.
- (7) Slowly release rod guide and remove rod guide, springs and piston rod.

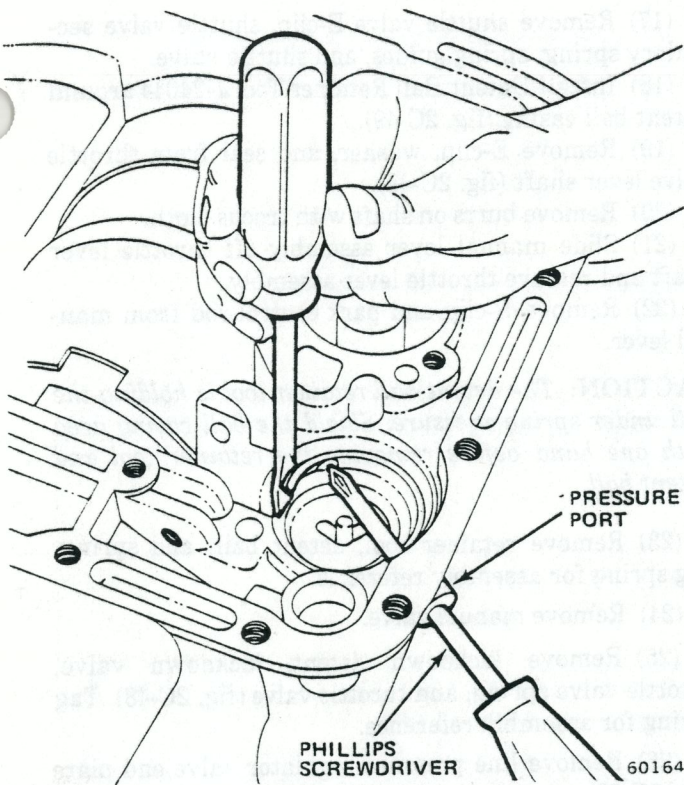

Fig. 2C-40 Front Servo Removal

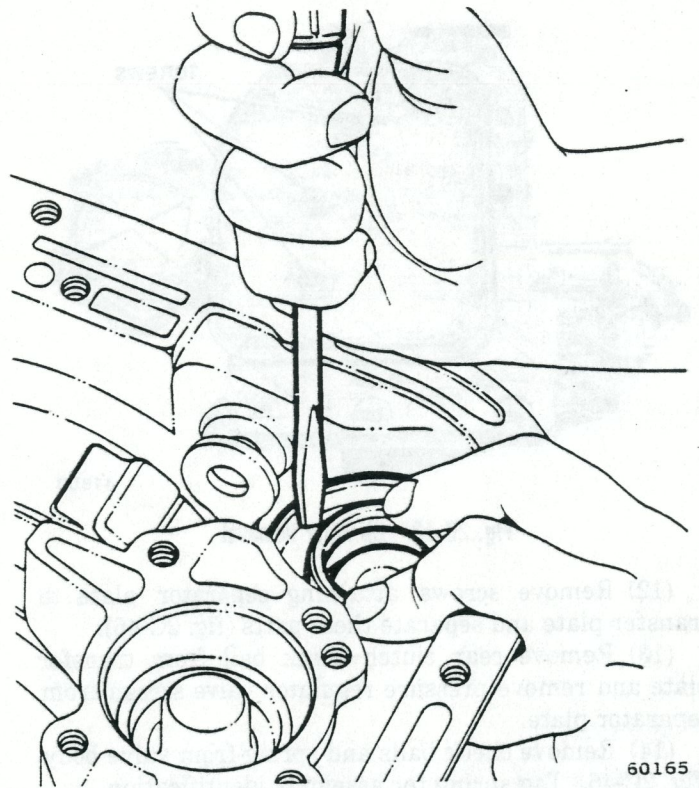

Fig. 2C-41 Rear Servo Spring and Snap Ring Removal

**CAUTION:** Do not grasp the rod with pliers to remove it. If the rod sticks in the case, tap it gently to release it.

- (8) Identify servo spring(s) with tag(s) for assembly reference.
- (9) Remove servo piston.

### Rear Servo

- (1) Compress piston spring and remove snap ring (fig. 2C-41).
- (2) Remove spring retainer, spring, piston and plug assembly. Identify spring with tag for assembly reference.

## SUBASSEMBLY OVERHAUL

### Valve Body

#### Disassembly

**CAUTION:** Do not clamp any part of the valve body or transfer plate in a vise. Any slight distortion of the body or plate will cause sticking valves or excessive leakage or both. When removing and installing valves or plugs, slide them in or out very carefully. Do not use force to remove or install valves.

- (1) Mount valve body on Repair Stand Tool J-24043.

**NOTE:** When disassembling the valve body, identify all valve springs with a tag for assembly reference.

- (2) Remove oil filter attaching screws and oil filter (fig. 2C-42).

**NOTE:** Oil filter screws are longer than transfer plate screws.

- (3) Remove screws attaching lockup module to valve body (fig. 2C-43).
- (4) Slide lockup module oil tube out of valve body and remove tube and module as an assembly.
- (5) Remove end plate from module.
- (6) Remove lockup valve and spring.
- (7) Remove fail-safe valve and spring.

**NOTE:** Tag springs and valves for reassembly reference.

- (8) Remove upper and lower screws from spring retainer and adjustment screw bracket (fig. 2C-44). Hold spring retainer firmly against spring force while removing last screw.

(9) Remove spring retainer, line and throttle pressure adjusting screws. Do not disturb screw settings. Remove line pressure and torque converter valve regulator springs. Tag springs for assembly reference.

- (10) Remove line pressure regulator and torque converter control valves (fig. 2C-44).

(11) Remove transfer plate assembly retaining screws and remove transfer plate assembly.

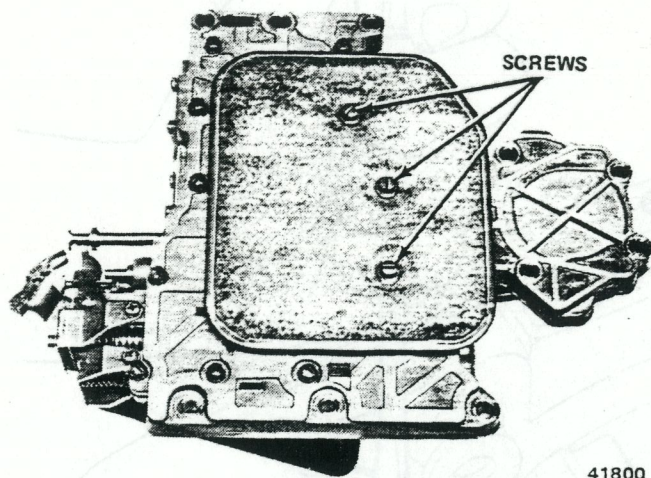

Fig. 2C-42 Oil Filter Removal

(12) Remove screws attaching separator plate to transfer plate and separate these parts (fig. 2C-45).

(13) Remove rear clutch check ball from transfer plate and remove pressure regulator valve screen from separator plate.

(14) Remove check balls and spring from valve body (fig. 2C-46). Tag spring for assembly identification.

(15) Turn valve body over and remove shuttle valve cover plate (fig. 2C-47).

(16) Remove governor plug end plate (fig. 2C-48), shuttle valve throttle plug and spring, and 1-2 and 2-3 shift valve governor plugs.

(17) Remove shuttle valve E-clip, shuttle valve secondary spring, spring guides, and shuttle valve.

(18) Install Detent Ball Retainer Tool J-24044 around detent ball casing (fig. 2C-49).

(19) Remove E-clip, washer, and seal from throttle valve lever shaft (fig. 2C-48).

(20) Remove burrs on shaft with crocus cloth.

(21) Slide manual lever assembly off throttle lever shaft and remove throttle lever assembly.

(22) Remove E-clip and park control rod from manual lever.

**CAUTION:** The detent ball retainer tool is holding the ball under spring pressure. Shield the ball casing area with one hand before removing the retainer tool and detent ball.

(23) Remove retainer tool, detent ball, and spring. Tag spring for assembly reference.

(24) Remove manual valve.

(25) Remove kickdown detent, kickdown valve, throttle valve spring, and throttle valve (fig. 2C-48). Tag spring for assembly reference.

(26) Remove line pressure regulator valve end plate (fig. 2C-50).

(27) Remove sleeve, line pressure regulator valve plug, and throttle pressure regulator valve plug.

(28) On model 999, remove downshift valve housing end plate.

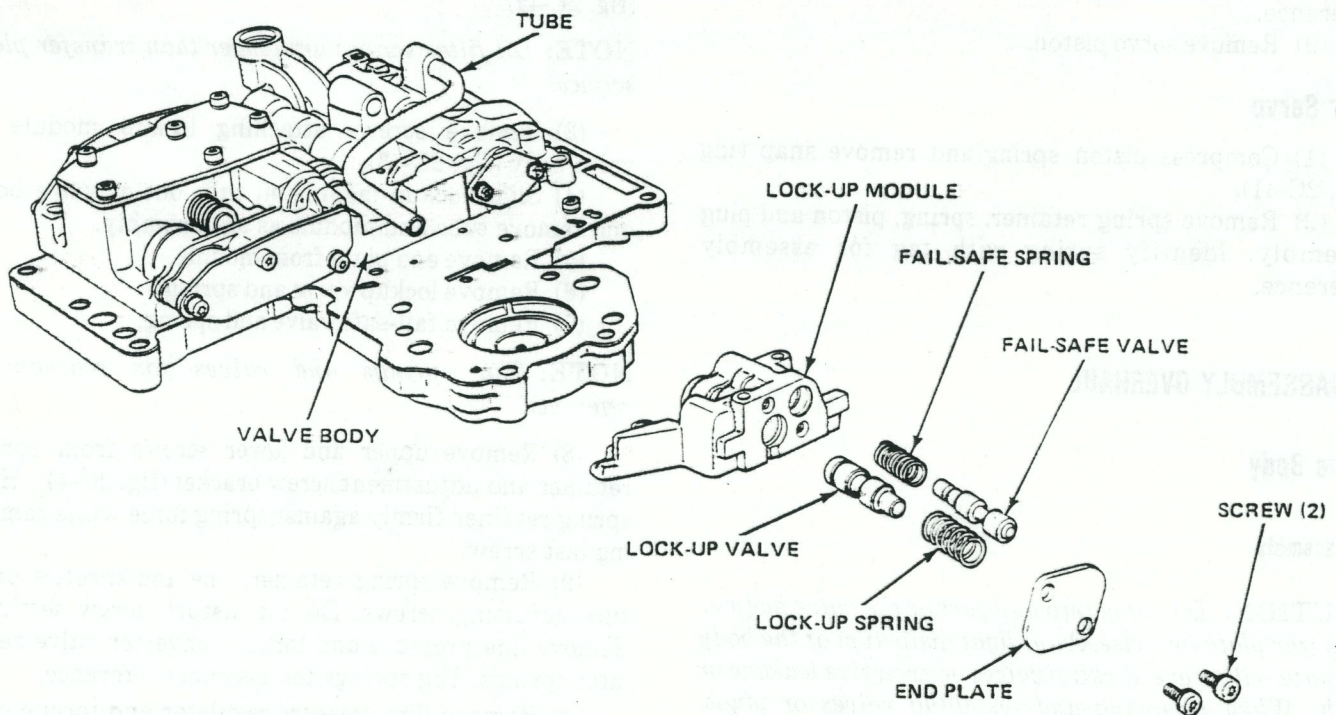
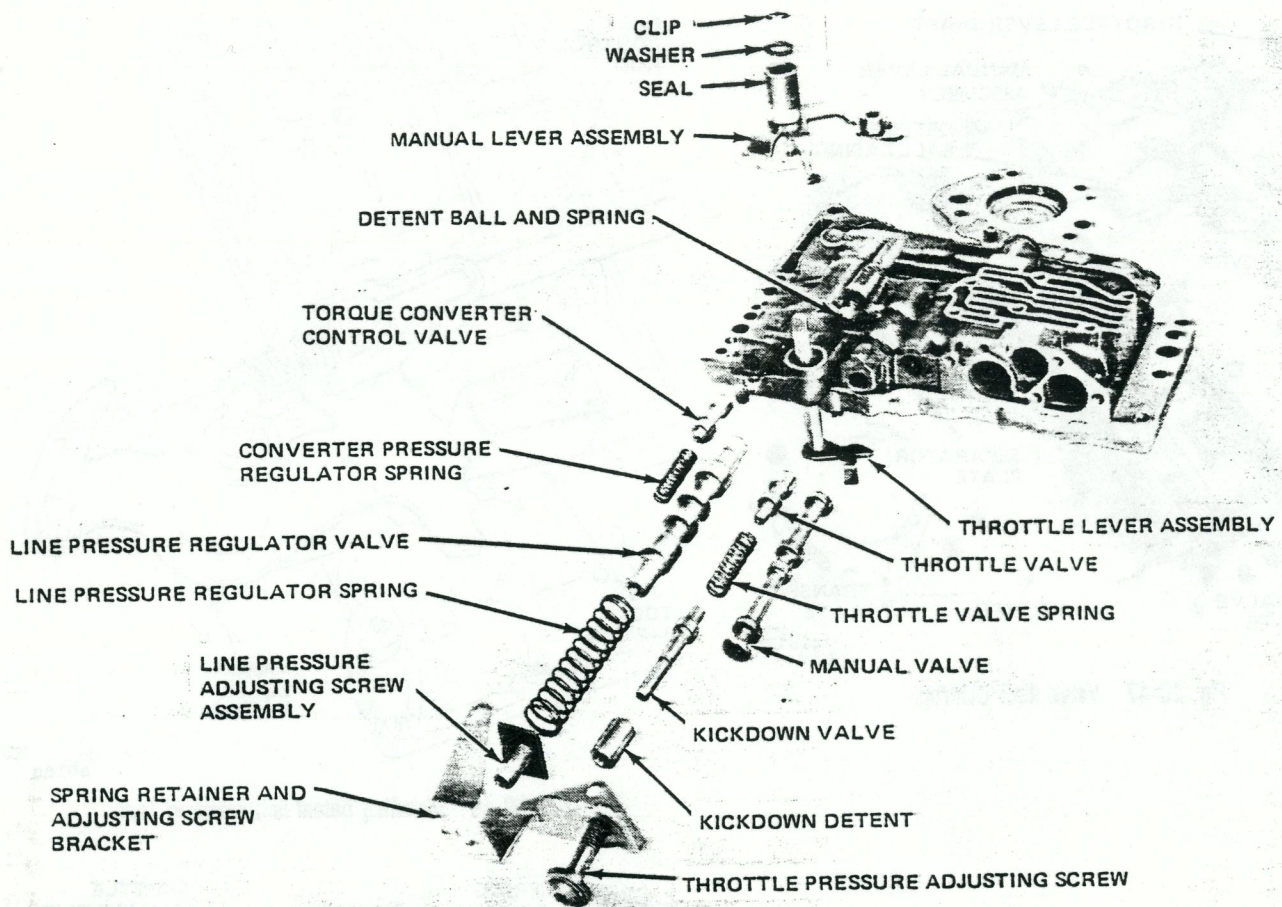

Fig. 2C-43 Lockup Module—Models 999/727



41809

Fig. 2C-44 Pressure Regulator and Manual Controls

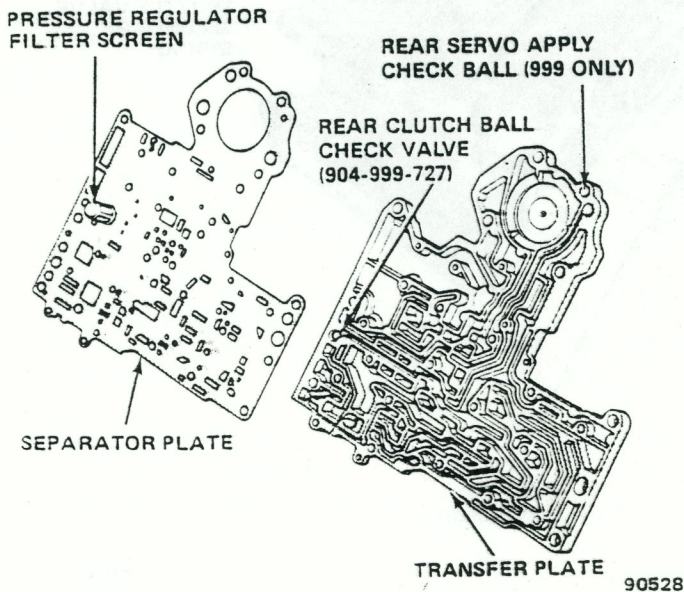

Fig. 2C-45 Transfer Plate Assembly

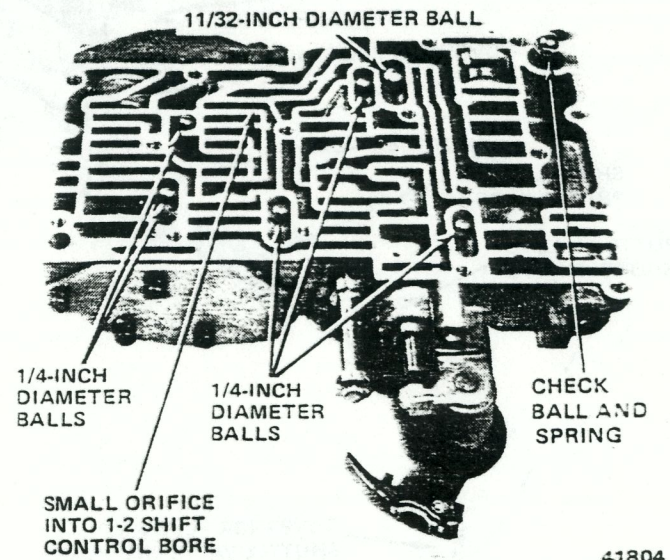

Fig. 2C-46 Check Ball Location

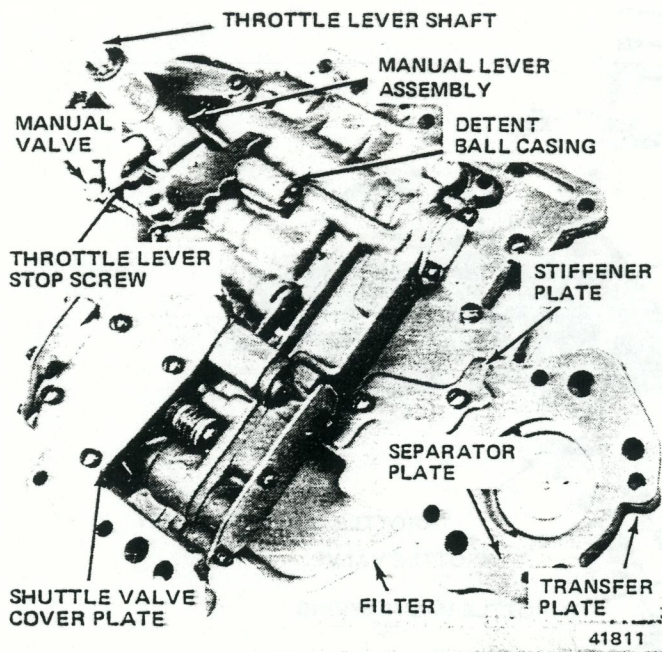

Fig. 2C-47 Valve Body Controls

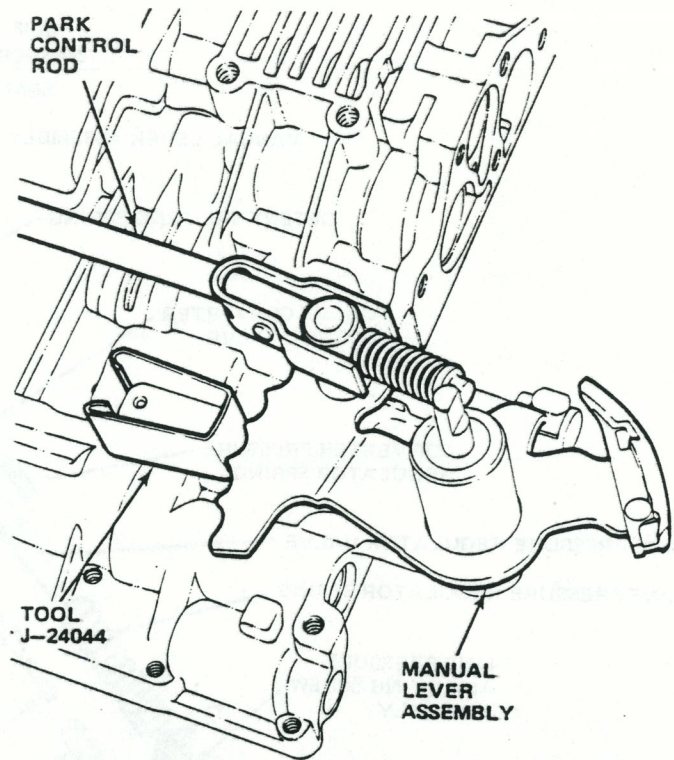

Fig. 2C-49 Installing Detent Ball Retaining Tool

60166

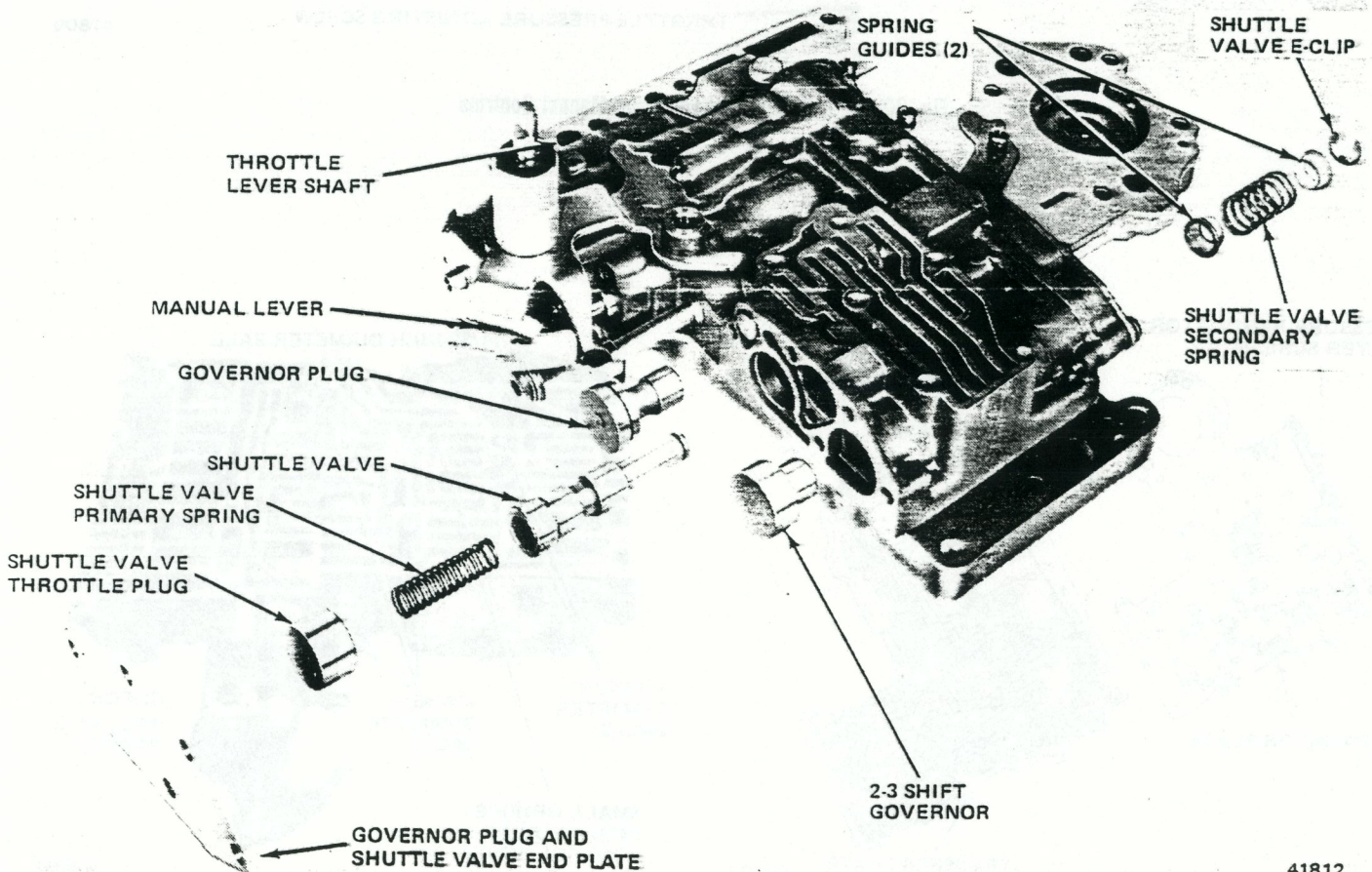

Fig. 2C-48 Shuttle Valve and Governor Plugs

41812



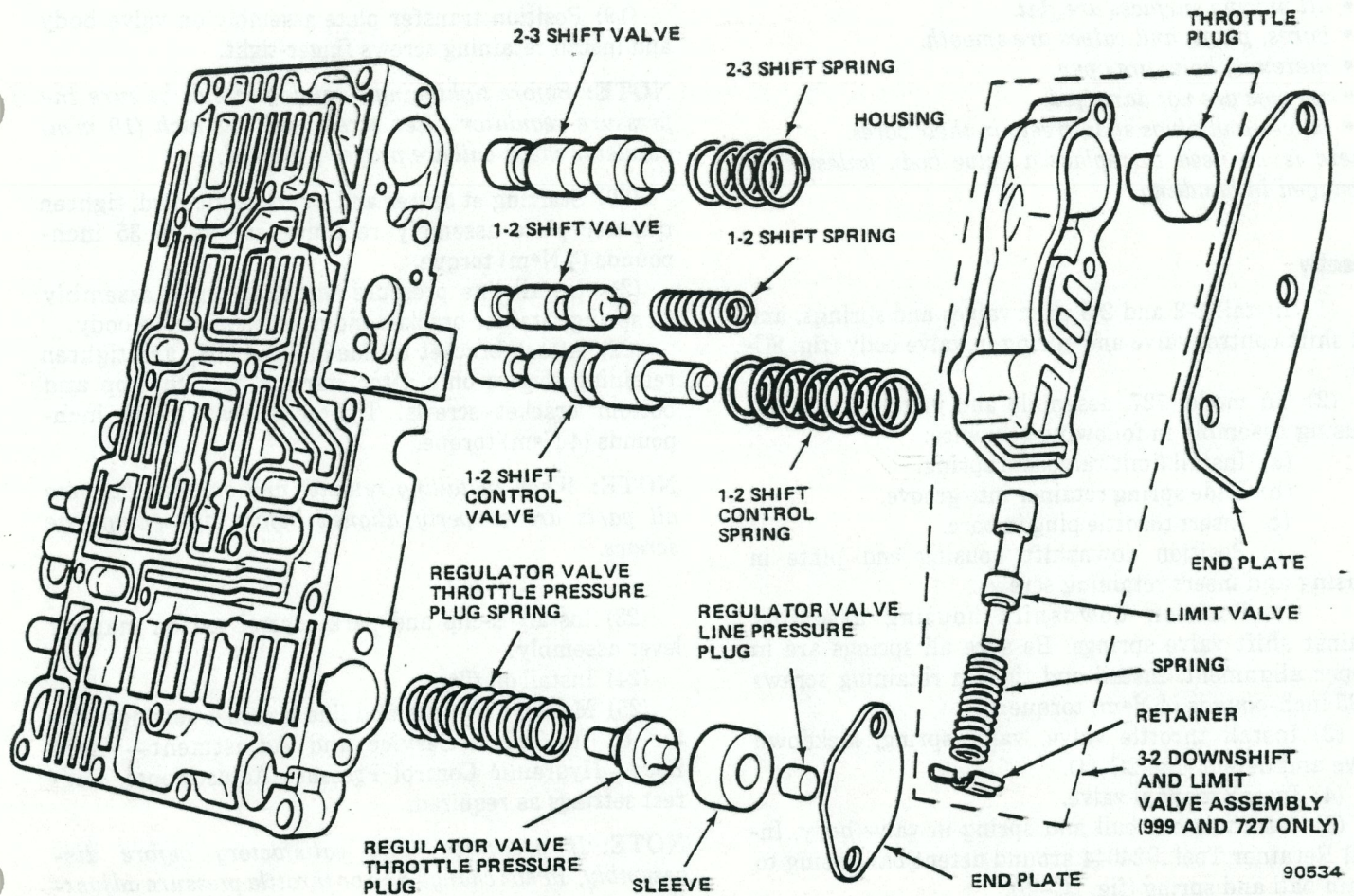

Fig. 2C-50 Shift Valves and Pressure Regulator Valves

(29) On model 727 only, remove downshift valve housing, remove throttle plug from downshift valve retainer, and remove spring, and limit valve from housing (fig. 2C-50). Tag spring for assembly reference.

(30) Remove 1-2 shift control valve and spring, 1-2 shift valve and spring, and 2-3 shift valve and spring. Tag all springs for assembly reference.

**Cleaning and Inspection**

Thoroughly wash and air dry all parts.

Do not use any type of caustic cleaning solution. Be sure all passages are clean and free from obstructions.

Clean the regulator filter in solvent and air dry. Replace the filter, if damaged.

Inspect the manual and throttle valve levers and shafts for being bent, worn or excessively loose. If a lever is loose on a shaft, it may be repaired by silver soldering or by replacing the lever and shaft assembly. If a lever or shaft is bent, replace the assembly.

Inspect all mating surfaces for burrs, nicks and scratches. Remove minor irregularities using crocus cloth and very light pressure.

Use a straightedge and inspect all mating surfaces for warpage or distortion. Very slight warpage or distortion

may be corrected by abrading the surface on a sheet of crocus cloth. Position the cloth on a surface plate or flat piece of glass and use very light pressure.

Be sure all metering holes in the separator plate and valve body are open. Use a penlight to inspect the bores in the valve body for corrosion, scores, burrs, scratches, pits, and other irregularities.

Inspect all valve springs for distortion or collapsed coils.

Inspect all valves and plugs for burrs, nicks, and scores. Remove slight irregularities using crocus cloth but do not round off the sharp edges. The sharpness of these edges is vitally important because it prevents foreign matter from lodging between the valve and the body bore.

Inspect all valves and plugs for freedom of operation in the valve body bores. When the bores, valves, and plugs are clean and dry, the valves and plugs fall freely in the bores. Make sure the orifice into the 1-2 shift control bore in the valve body is open (fig. 2C-44). Verify this by inserting a 1/32-inch (.79 mm) diameter drill through the orifice and into the 1-2 shift control bore.

**NOTE:** A valve body that functioned properly when the vehicle was new will operate correctly after cleaning, reconditioning, assembly, and adjustment if:

- all mating surfaces are flat.
- bores, plugs, and valves are smooth.
- metering holes are open.
- springs are not damaged.
- valves and plugs slide freely in their bores.

There is no need to replace a valve body unless it is damaged in handling.

### Assembly

(1) Install 1-2 and 2-3 shift valves and springs, and 1-2 shift control valve and spring in valve body (fig. 2C-50).

(2) On model 727, assemble and install downshift housing assembly in following sequence:

- Install limit valve and spring.
- Slide spring retainer into groove.
- Insert throttle plug in bore.

(d) Position downshift housing end plate in housing and insert retaining screws.

(e) Position downshift housing assembly against shift valve springs. Be sure all springs are in proper alignment. Install and tighten retaining screws to 35 inch-pounds (4 N•m) torque.

(3) Install throttle valve, valve spring, kickdown valve and detent (fig. 2C-44).

(4) Install manual valve.

(5) Insert detent ball and spring in valve body. Install Retainer Tool J-24044 around detent ball casing to retain ball and spring (fig. 2C-49).

(6) Install throttle lever assembly (fig. 2C-44).

(7) Install manual lever assembly on throttle lever shaft. Position manual lever assembly so it engages manual valve and detent ball.

(8) Install seal, washer, and E-clip on throttle lever shaft.

(9) Remove detent ball retainer tool.

(10) Install 1-2 and 2-3 shift valve governor plugs (fig. 2C-48).

(11) Install shuttle valve, primary spring and throttle plug.

(12) Install governor plug end plate and tighten screws to 35 inch-pounds (4 N•m) torque.

(13) Install spring guides, shuttle valve secondary spring, and E-clip.

(14) Install shuttle valve cover plate (fig. 2C-55) and tighten screws to 35 inch-pounds (4 N•m) torque.

(15) Install check balls and spring in valve body (fig. 2C-46).

(16) Install rear clutch check ball in transfer plate and install pressure regulator valve screen in separator plate (fig. 2C-44).

(17) Position separator plate on transfer plate and stiffener plate on separator plate.

(18) Install stiffener and separator plate-to-transfer plate retaining screws. Tighten screws to 35 inch-pounds (4 N•m) torque.

(19) Position transfer plate assembly on valve body and install retaining screws finger-tight.

**NOTE:** Before tightening retaining screws be sure the pressure regulator filter screen and 3/8-inch (10 mm) diameter check ball are properly aligned.

(20) Starting at center and working outward, tighten transfer plate assembly retaining screws to 35 inch-pounds (4 N•m) torque.

(21) Install line pressure adjusting screw assembly on spring retainer bracket and position on valve body.

(22) Attach bracket to side of valve body and tighten retaining screws only after starting both the top and bottom bracket screws. Tighten screws to 35 inch-pounds (4 N•m) torque.

**NOTE:** When installing retainer and bracket, be sure all parts are properly aligned before tightening the screws.

(23) Install E-clip and park control rod on manual lever assembly.

(24) Install oil filter.

(25) Measure throttle and line pressure settings. Refer to In-Vehicle Service and Adjustment—Valve Body—Hydraulic Control Pressure Adjustments. Correct settings as required.

**NOTE:** If pressures were satisfactory before disassembly, do not change line or throttle pressure adjusting screw settings.

### Accumulator Piston and Spring—Inspection

Inspect the piston for nicks, burrs, scores, and wear. Be sure the rings turn freely in the piston grooves. Inspect the case bore for scores or other damage.

Inspect the spring for cracks or distortion. Replace damaged or worn parts.

### Adapter Housing Bearing and Seal Replacement

(1) Remove seal from extension housing using screwdriver or punch.

(2) Remove snap rings and remove bearing from housing.

(3) Install replacement bearing in housing and install snap rings.

(4) Install replacement seal in housing. Seat seal flush with edge of seal bore in housing.

### Park Lock Sprag

#### Disassembly

(1) Remove pivot shaft from adapter housing (fig. 2C-28).

(2) Remove park sprag and spring.

(3) Remove snap ring and reaction plug and pin assembly from housing.

### Inspection

Inspect the pivot shaft for scores and free movement in the housing and sprag. Inspect the control rod and sprag springs for distortion and loss of tension. Inspect the sprag and gear for cracks and broken edges on the engagement lugs. Inspect the knob at the end of the control rod for excessive wear, nicks, burrs, and free turning.

If necessary, replace the park gear as outlined under Governor and Support—Disassembly and Assembly.

### Assembly

- (1) Install reaction plug and pin assembly in housing and install snap ring.
- (2) Install sprag and spring in housing.

**NOTE:** *The square lug on the sprag must face the park gear.*

- (3) Position spring so it moves sprag away from gear.
- (4) Install pivot pin.

## Governor

### Disassembly

- (1) Remove large snap ring from weight end of governor body (fig. 2C-27).
- (2) Remove weight assembly.
- (3) Remove snap ring from governor weight assembly.
- (4) Separate inner weight, spring, and outer weight.

**NOTE:** *If park gear or governor body are to be replaced, straighten the lock tabs and remove the four attaching bolts.*

### Inspection

Thoroughly clean and dry all governor parts and check for free movement. Do not use a caustic cleaning solution.

The weights and valve should fall freely in their bores when clean and dry. Rough surfaces and burrs may be polished with crocus cloth.

Inspect the governor weight spring for distortion.

Inspect the park gear and governor support for chipped or worn gear teeth and damaged ring grooves.

Clean the filter in solvent and air dry. Replace it if damaged or defective.

### Assembly

(1) If governor body was separated from park gear, assemble parts and install attaching bolts finger-tight.

**NOTE:** *The bolts must not be tightened to specified torque until the assembly is installed on the output shaft.*

- (2) Install governor weights and spring in outer weight, and install snap ring.
- (3) Install weight assembly into body.
- (4) Install snap ring.

## Oil Pump and Reaction Shaft Support—Model 904/999

### Disassembly

- (1) Remove bolts attaching pump to support and remove support.
- (2) Mark pump rotors with chalk for assembly reference.
- (3) Remove rotors (fig. 2C-51).
- (4) Remove O-ring seal using blunt punch.
- (5) Remove front clutch seal rings from support.

### Inspection

Inspect the front clutch seal ring grooves for burrs, nicks, or cracked edges. Inspect the front clutch retainer-to-reaction shaft support thrust washer for wear. The washer should be 0.043 to 0.045 inch (1.09 to 1.14 mm) thick. Inspect all machined surfaces on the pump housing and support for nicks and burrs. Inspect the pump body and reaction shaft support bushings for wear and scores. Inspect the pump rotors for scores or pits.

Install the pump rotors in the pump body. Place a straightedge across the rotor faces and pump body. Using a feeler gauge, measure the clearance between the straightedge and pump rotors. Clearance limits are 0.001 to 0.003 inch (0.02 to 0.07 mm) (fig. 2C-52).

Position the inner and outer rotors so that the center of one tooth on each rotor is aligned. Measure the clearance between the tips of the teeth. Make four measurements. Rotate the inner rotor approximately 1/4 turn (90°) between measurements. Rotor tip clearance should be 0.005 to 0.010 inch (0.13 to 0.25 mm) (View A, fig. 2C-53).

Measure the clearance between the outer surface of the outer rotor and the pump bore. The clearance should be 0.004 to 0.008 inch (0.10 to 0.20 mm) (View B, fig. 2C-49).

### Pump Bushing Replacement

- (1) Position pump housing, with reaction shaft support mating surface facing downward, on flat, level surface.

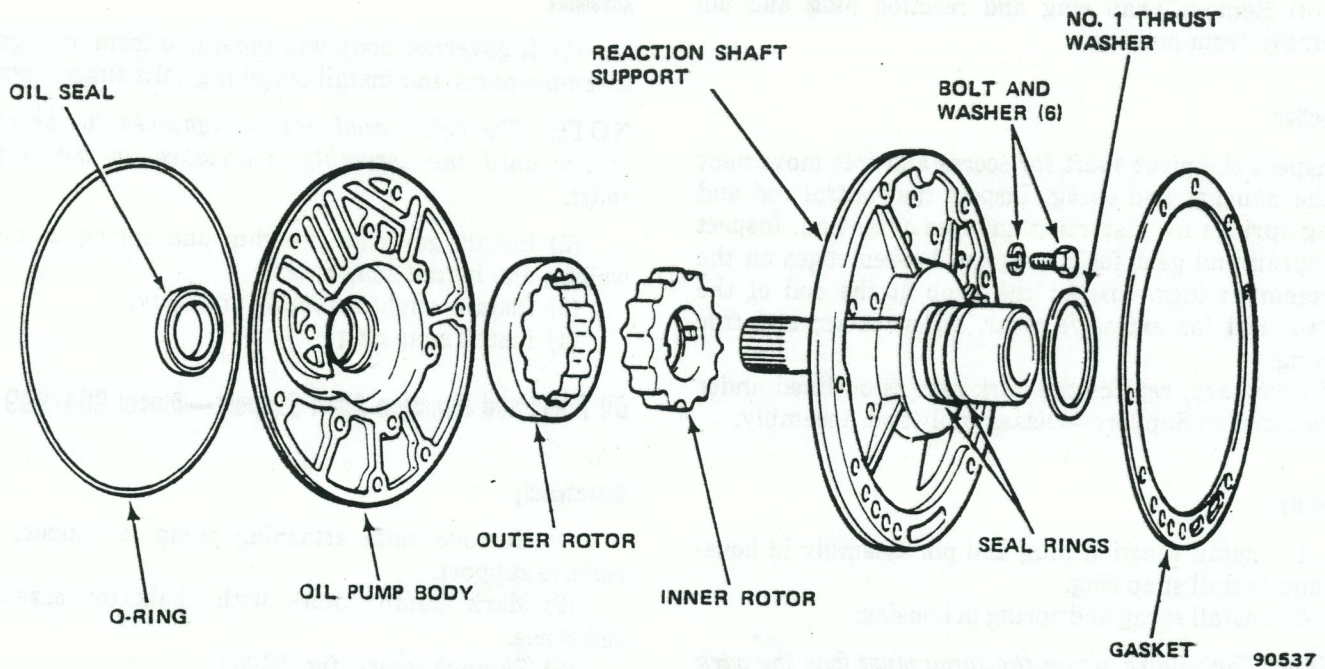
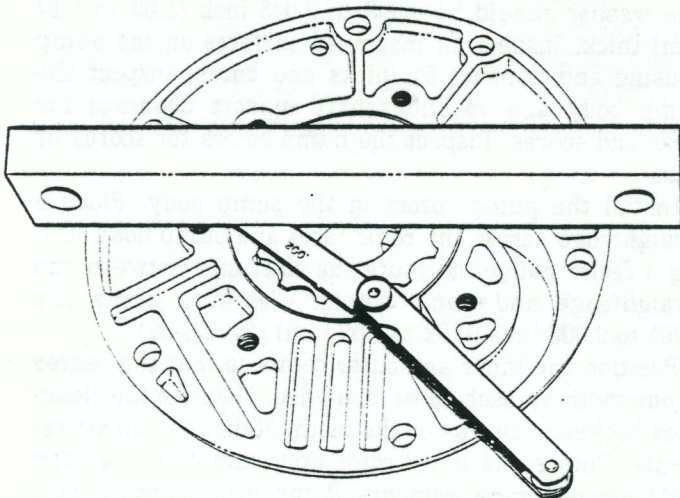

Fig. 2C-51 Oil Pump Assembly—Models 904/999

(2) Remove bushing using Remover and Installer Tool J-24049 and Driver Handle J-8092 (fig. 2C-54).

**NOTE:** Be careful to keep the tool straight in the bore during removal.



60167

Fig. 2C-52 Measuring Pump Rotor End Clearance—Model 904/999

(3) Position replacement bushing on Installer Tool J-24049.

(4) Turn pump housing over and install bushing straight into housing until edge of bushing is flush with bore (fig. 2C-55).

(5) Stake bushing in two places (to retain it) using blunt punch (fig. 2C-56).

(6) Use knife, with narrow blade only, to remove burrs or high points at stake points (fig. 2C-56). Do not

use file or other tool that will remove more metal than is necessary.

#### Reaction Shaft Bushing Replacement

**NOTE:** If the reaction shaft bushing requires replacement, be sure to inspect the support for wear at the input shaft and rear clutch retainer seal ring lands. If the lands are worn or grooved, replace the entire support assembly.

**CAUTION:** Do not clamp any part of the reaction shaft or support in a vise.

(1) Thread Bushing Remover Tool J-24036 straight into bushing as far as possible by hand (fig. 2C-57).

(2) Using wrench, thread remover tool into bushing three or four additional turns to fully engage threads of tool in bushing.

(3) Install Slide Hammer Tools J-7004-3 and J-6585-1 in remover tool (fig. 2C-57).

(4) Bump outward with slide hammers to remove bushing.

(5) Clean chips from reaction shaft support assembly.

(6) Grip old bushing with pliers and remove it from Tool J-24036.

**CAUTION:** Be sure to protect the remover tool threads when using the tool.

(7) Thread Bushing Installer Tool J-24032 onto Driver Handle J-8092 (fig. 2C-58).

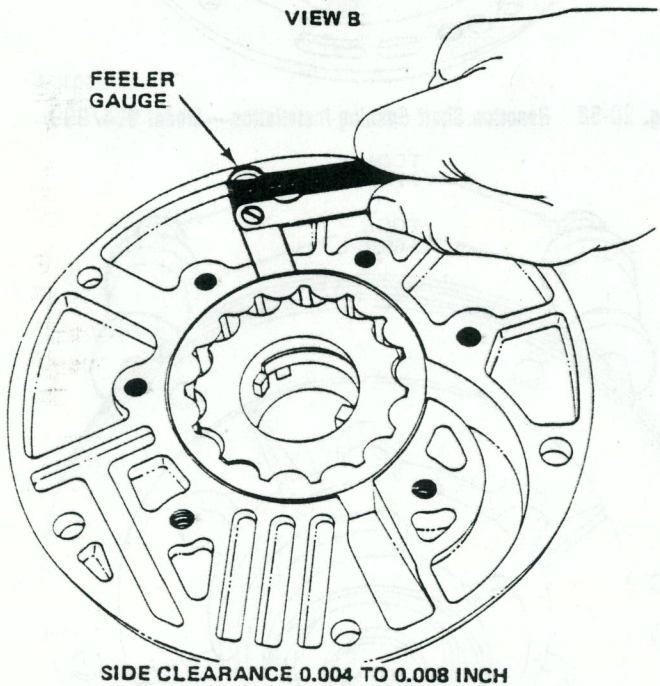
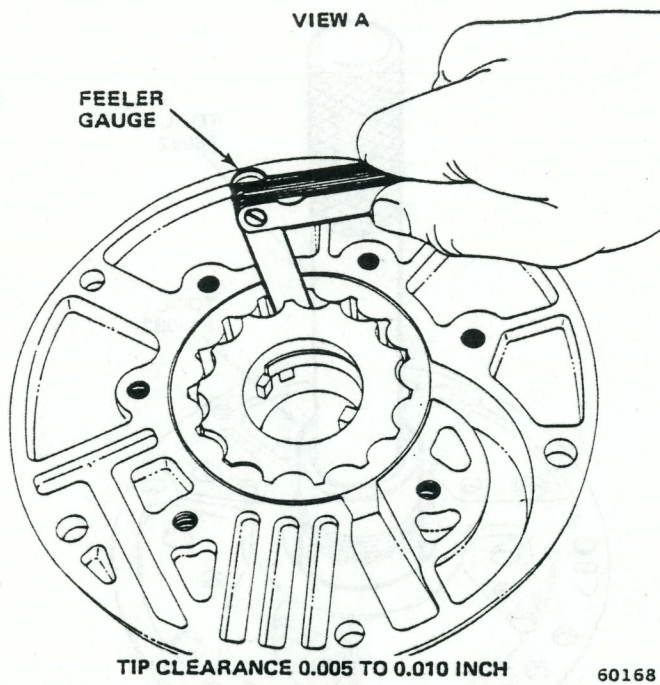

Fig. 2C-53 Measuring Rotor Clearance—Model 904/999

(8) Position replacement bushing on installer tool and install bushing straight into shaft bore until tool bottoms (fig. 2C-58).

(9) Clean reaction shaft support thoroughly after bushing installation.

**Assembly**

(1) Position pump housing on smooth flat surface and install pump rotors.

**NOTE:** *New rotors may be installed with either face up. Used rotors must be installed as removed. Refer to reference chalk marks made during disassembly.*

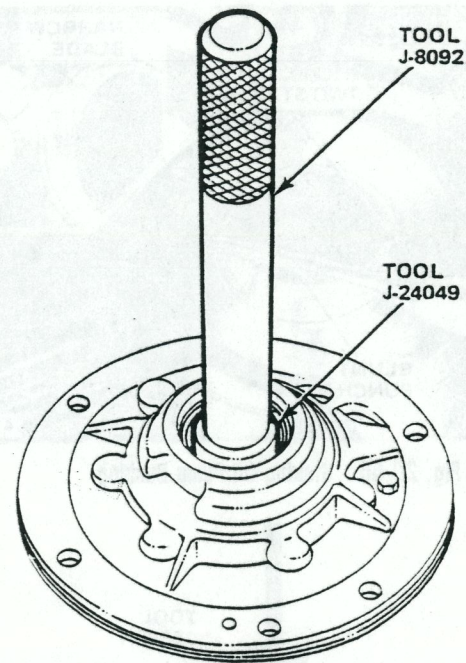

Fig. 2C-54 Pump Bushing Removal—Model 904/999

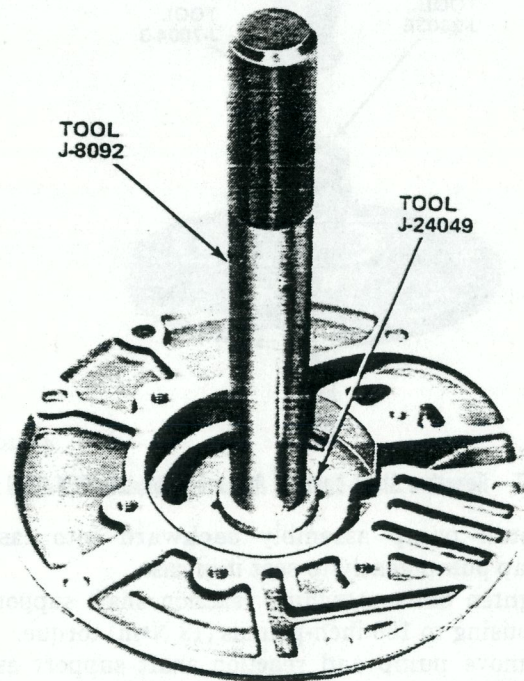

Fig. 2C-55 Pump Bushing Installation—Models 904/999

(2) Align and install reaction shaft support on pump housing and finger-tighten attaching bolt.

(3) Insert two Slide Hammers J-6585-1 and Bolts J-7004-3, from back to front, into threaded reaction shaft support holes (fig. 2C-59). Bolts should be threaded into support until ends of bolts are 1/16-inch (1.6 mm) below front machined surface of pump housing.

(4) Install one Pilot Stud Tool J-3387-2 into case pump opening (fig. 2C-60).

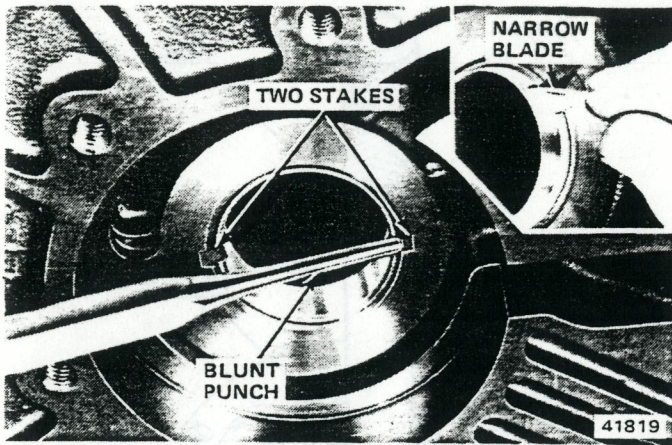

Fig. 2C-56 Staking Oil Pump Bushing

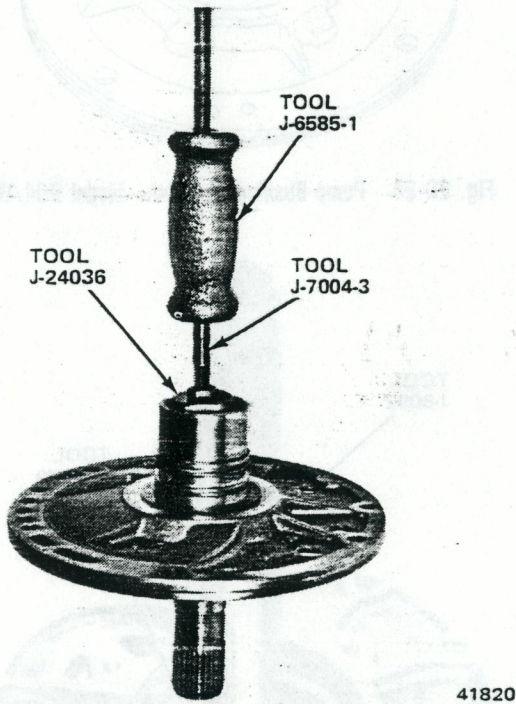

Fig. 2C-57 Reaction Shaft Bushing Removal—Models 904/999

(5) Install pump assembly backward into case opening. Tap pump gently to seat it in case.

(6) Tighten bolts attaching reaction shaft support to pump housing to 160 inch-pounds (19 N•m) torque.

(7) Remove pump and reaction shaft support assembly from case.

(8) Remove slide hammer tools from pump.

(9) Position oil seal in pump housing with seal lip facing inward.

(10) Install seal using Installer Tool J-9617. Install seal into housing until tool bottoms.

**Disassembly**

(1) Remove pump-to-support attaching bolts and remove support from pump (fig. 2C-61).

(2) Mark rotors with chalk for assembly alignment reference.

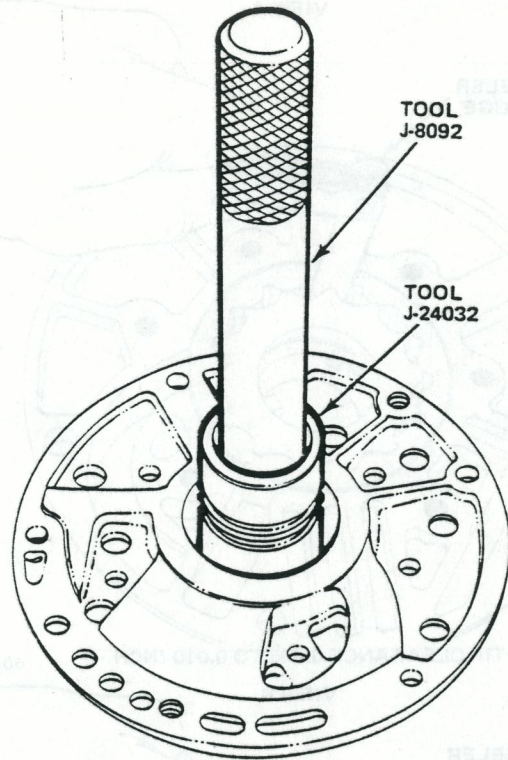

Fig. 2C-58 Reaction Shaft Bushing Installation—Model 904/999

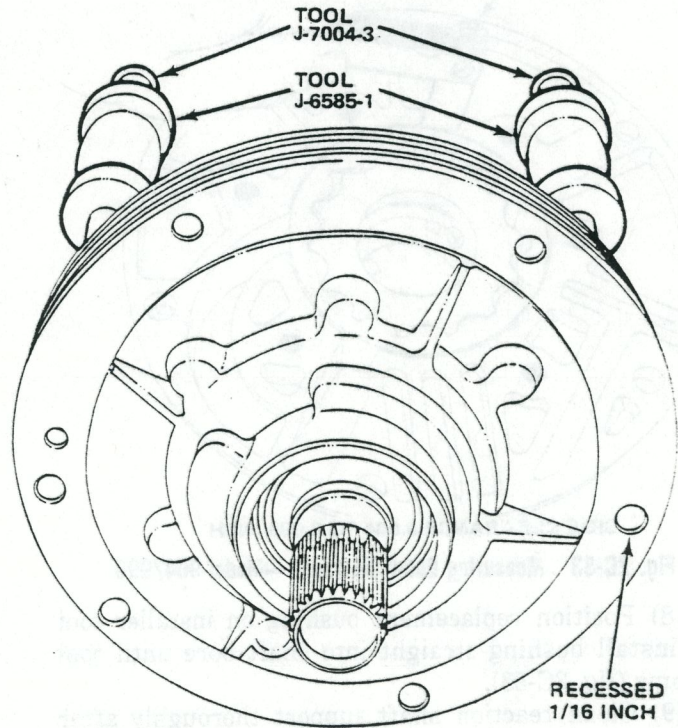

Fig. 2C-59 Installing Slide Hammer Bolts

- (3) Remove rotors
- (4) Remove O-ring seal.
- (5) Remove O-ring seal from pump body flange.
- (6) Remove front oil seal using blunt punch.
- (7) Remove front clutch seal rings from support.

Oil Pump and Reaction Shaft Support—Model 727

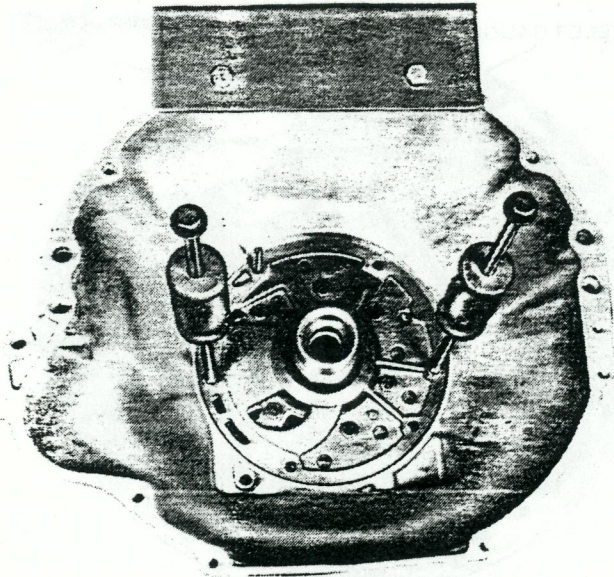

Fig. 2C-60 Pump Alignment—Model 904/999

Inspection

Inspect the front clutch seal ring grooves for burrs, nicks, or cracked edges. Inspect all machined surfaces on the pump housing for nicks and burrs. Inspect the pump body and reaction shaft support bushings for wear and scores. Inspect the pump rotors for scores and pits.

Install the pump rotors in the pump body. Position a straightedge across the rotor faces and pump body and use a feeler gauge to measure the clearance between the straightedge and rotors. Clearance limits are 0.001 to 0.003 inch (0.02 to 0.07 mm) (fig. 2C-62).

Position the inner and outer rotors so that the center of one tooth on each rotor is aligned and measure the clearance between the tips of the teeth. Make four measurements. Rotate the inner rotor approximately 1/4 turn (90°) between measurements. Rotor tip clearance should be 0.005 to 0.010 inch (0.13 to 0.20 mm) (View A, fig. 2C-63).

Measure the clearance between the outer surface of the outer rotor and the pump bore. Clearance should be 0.004 to 0.008 inch (0.10 to 0.20 mm) (View B, fig. 2C-63).

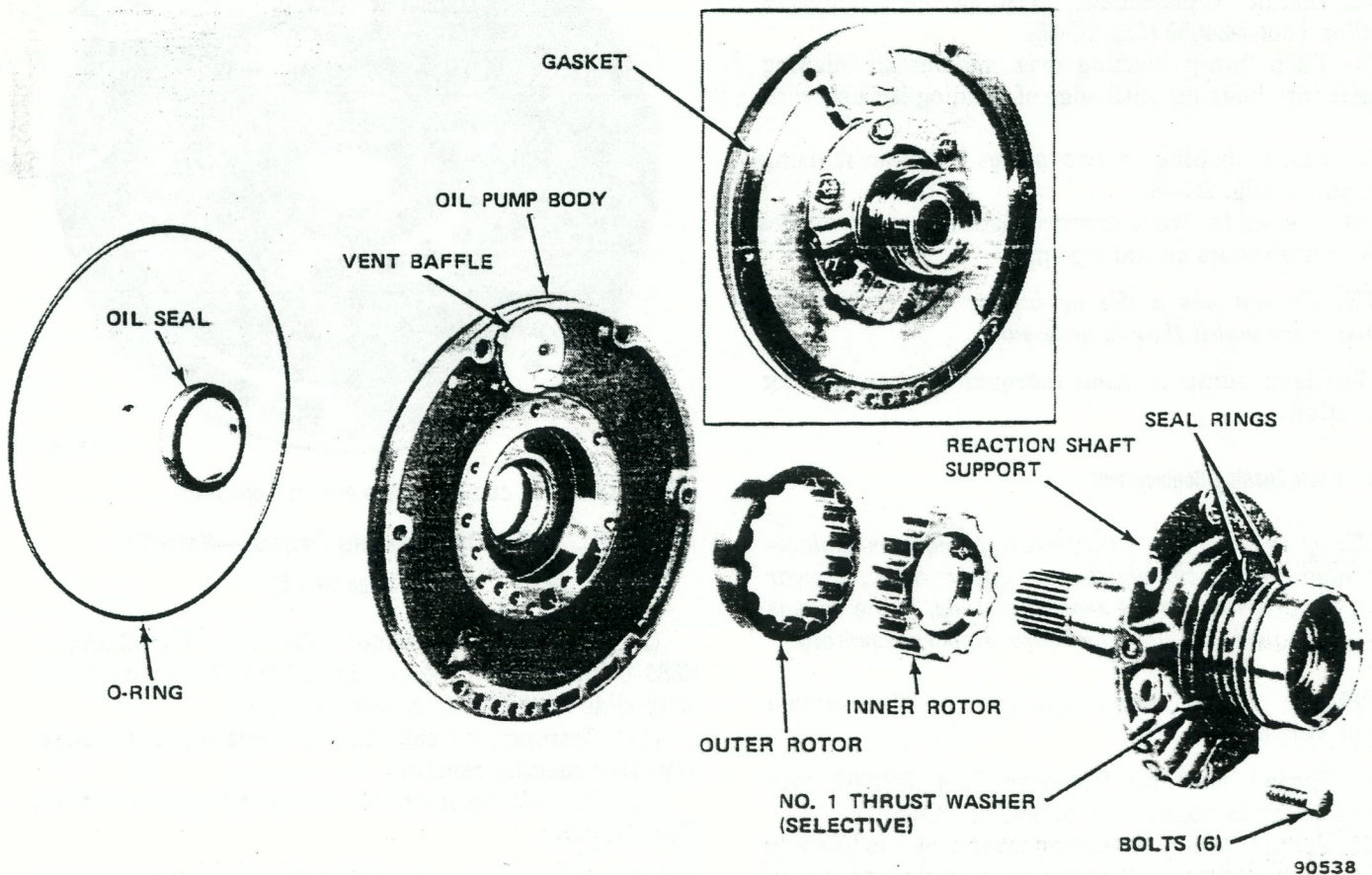

90538

Fig. 2C-61 Oil Pump Assembly—Model 727

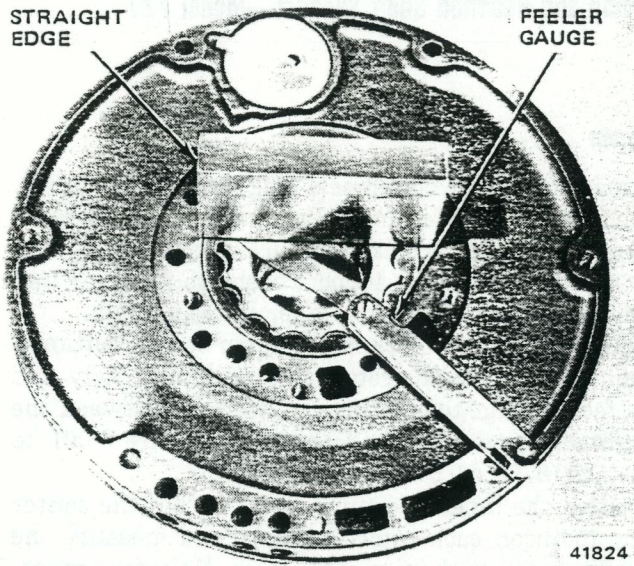

Fig. 2C-62 Measuring Rotor End Clearance—Model 727

**Pump Bushing Replacement**

(1) Place pump housing, with reaction shaft support mating surface facing downward, on flat, level surface.

(2) Remove bushing using Remover/Installer Tool J-24055 and Driver Handle J-8092 (fig. 2C-64).

(3) Install replacement bushing on Remover/Installer Tool J-24055 (fig. 2C-65).

(4) Turn pump housing over and install bushing straight into housing until edge of bushing is flush with bore.

(5) Stake bushing in two places to retain it using blunt punch (fig. 2C-56).

(6) Use knife, with narrow blade only, to remove burrs or high spots at stake points.

**NOTE:** Do not use a file or similar tool that might remove more metal than is necessary.

(7) Clean pump housing thoroughly after bushing installation.

**Reaction Shaft Bushing Replacement**

**NOTE:** If the reaction shaft bushing requires replacement, also inspect the shaft and support bore for wear caused by the input shaft seal ring lands. If the bore is worn or grooved, replace the entire support assembly.

**CAUTION:** Do not clamp any part of the reaction shaft or support in a vise.

(8) Thread Bushing Remover Tool J-24037 into bushing as far as possible by hand (fig. 2C-66).

(9) Using wrench, thread remover tool into bushing three to four additional turns to fully engage threads of tool in bushing.

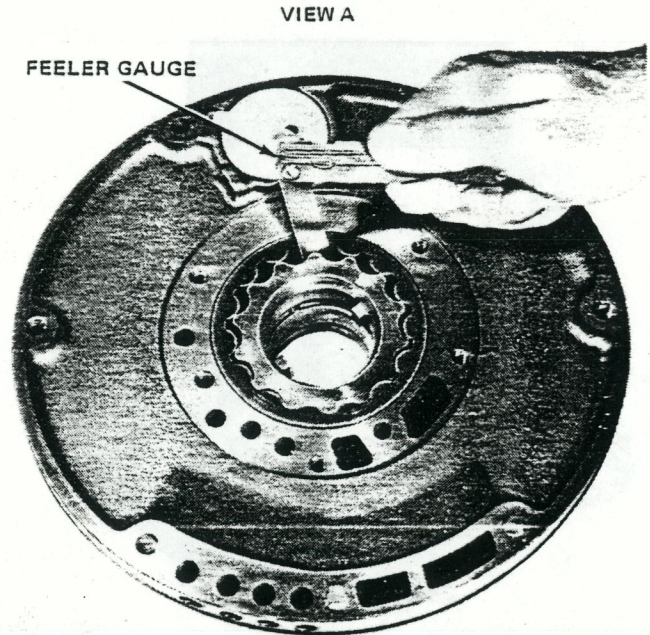

TIP CLEARANCE 0.005 TO 0.010 INCH

VIEW B

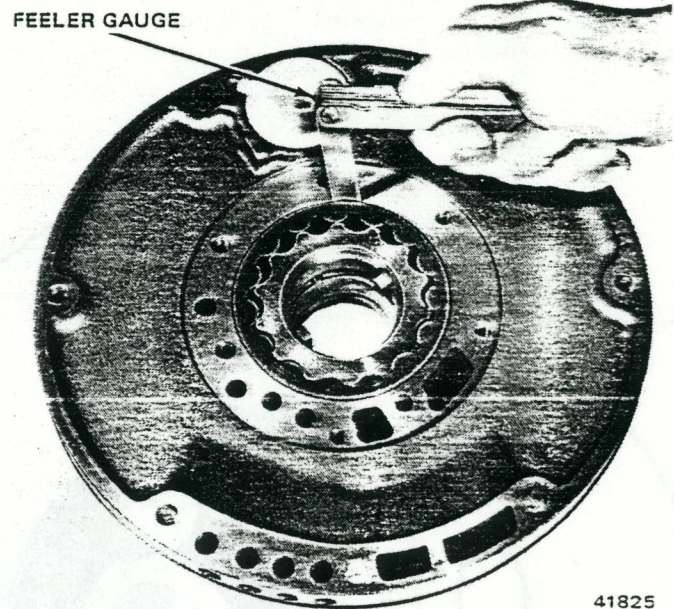

SIDE CLEARANCE 0.004 TO 0.008 INCH

Fig. 2C-63 Measuring Rotor Clearance—Model 727  
(View A and View B)

(10) Install Slide Hammer Bolts Tool J-7004-3 and J-6585-1 into remover tool (fig. 2C-66). Bump outward with slide hammers to remove bushing.

(11) Thoroughly clean reaction shaft support assembly after bushing removal.

(12) Grip old bushing with pliers and remove it from Tool J-24037.

**NOTE:** Be sure to protect the threads on the remover tool when using the tool.



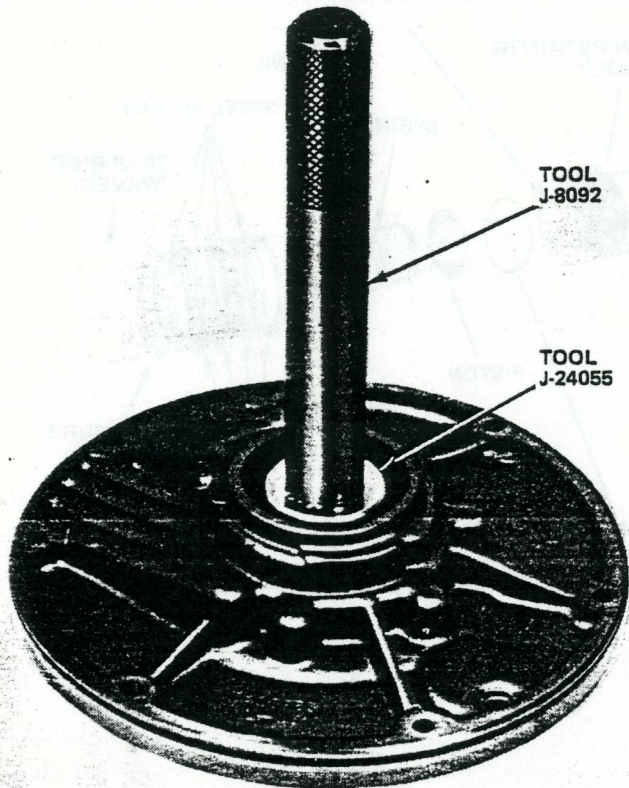

41826

Fig. 2C-64 Pump Bushing Removal—Model 727

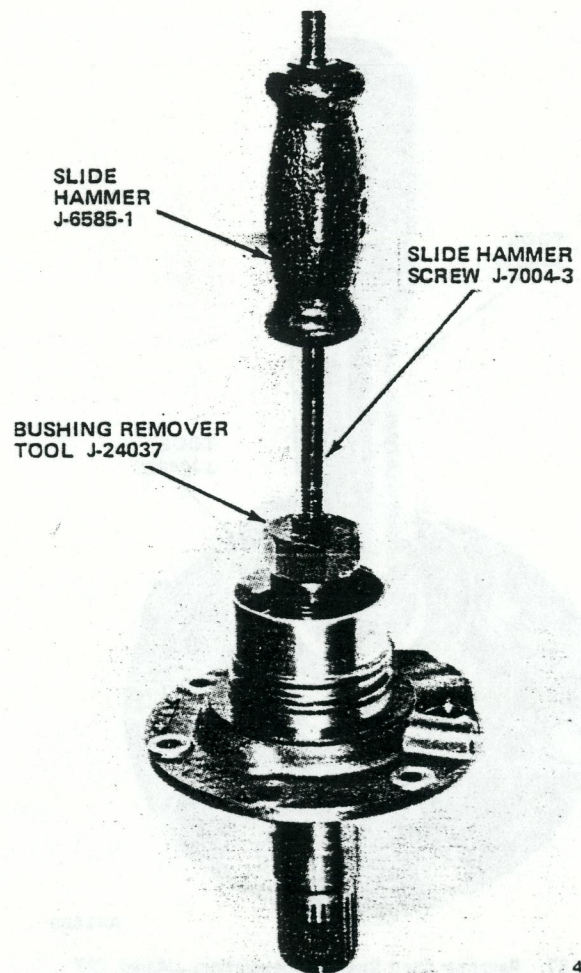

41828

Fig. 2C-66 Reaction Shaft Bushing Removal—Model 727

#### Assembly

- (1) Install pump rotors in housing.
- (2) Install reaction shaft support and tighten attaching bolts to 160 inch-pounds (18 N•m) torque.
- (3) Install O-ring seal around pump housing flange.
- (4) Install oil seal pump housing with seal lip facing inward.
- (5) Install oil seal on Installer Tool J-21005. Install seal straight into housing until tool bottoms.
- (6) Thoroughly clean reaction shaft support assembly.

#### Front Clutch—Model 904/999

##### Disassembly

- (1) Remove large waved snap ring which secures pressure plate in clutch retainer (fig. 2C-68).
- (2) Install Spring Compressor Tool J-5886-01 over piston spring retainer (fig. 2C-69).
- (3) Compress piston springs and remove snap ring.
- (4) Release compressor tool slowly until spring retainer is free of hub.

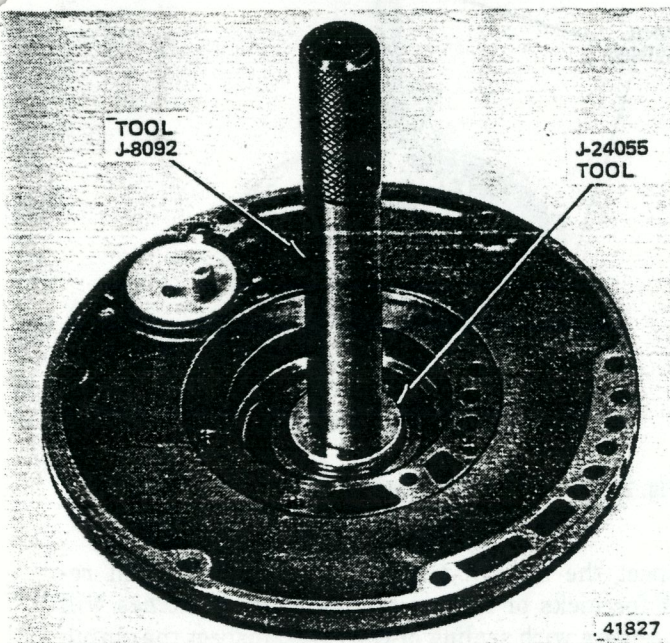

41827

Fig. 2C-65 Pump Bushing Installation—Model 727

(13) Thread Bushing Installer Tool J-24038 onto Driver Handle J-8092 (fig. 2C-67).

(14) Position replacement bushing on installer tool and install bushing straight into shaft bore until tool bottoms.

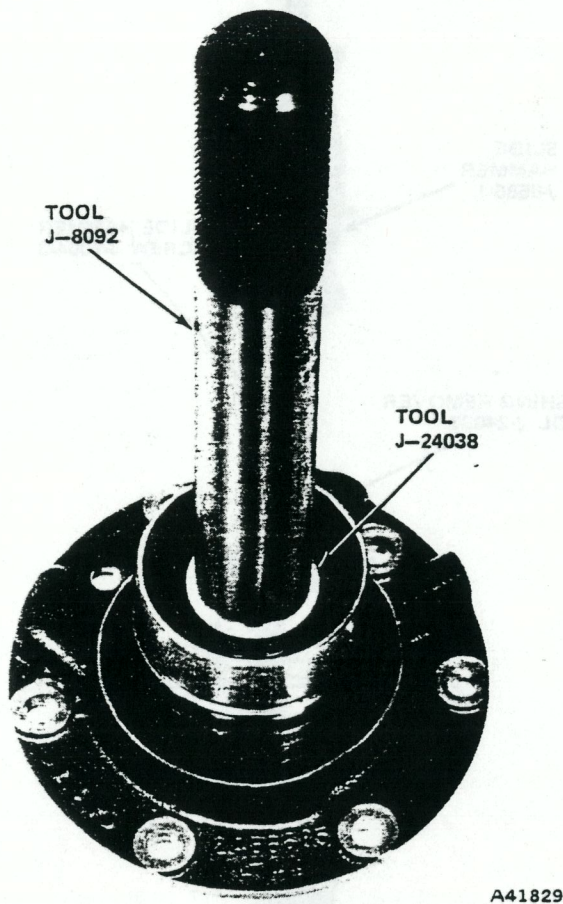

Fig. 2C-67 Reaction Shaft Bushing Installation—Model 727

**NOTE:** When releasing the compressor tool, do not allow the spring retainer to stick or bind in the snap ring groove.

- (5) Remove tool, retainer and spring.
- (6) Turn clutch retainer over and bump on wood block to dislodge and remove piston.
- (7) Remove seal rings from piston and clutch retainer hub.

**Inspection**

Inspect the friction material on all driving discs. Replace discs that are charred, glazed, heavily pitted, flaking or if the friction material can be scraped off easily.

Inspect the steel plates and pressure plate surfaces for overheating, scoring, and for damaged driving lugs. Replace any worn, damaged parts.

Inspect the steel plate lug grooves in the clutch retainer for smooth surfaces. The plates must slide freely in the grooves.

Inspect the band application surface on the clutch retainer for nicks and scores. Light scratches and nicks can be removed with crocus cloth.

Inspect the ball check in the clutch retainer. The ball should move freely in its cage.

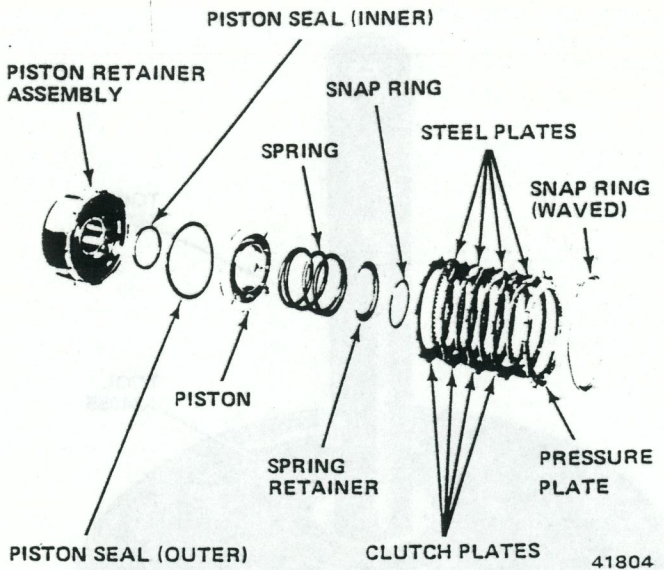

Fig. 2C-68 Front Clutch Assembly—Model 904/999

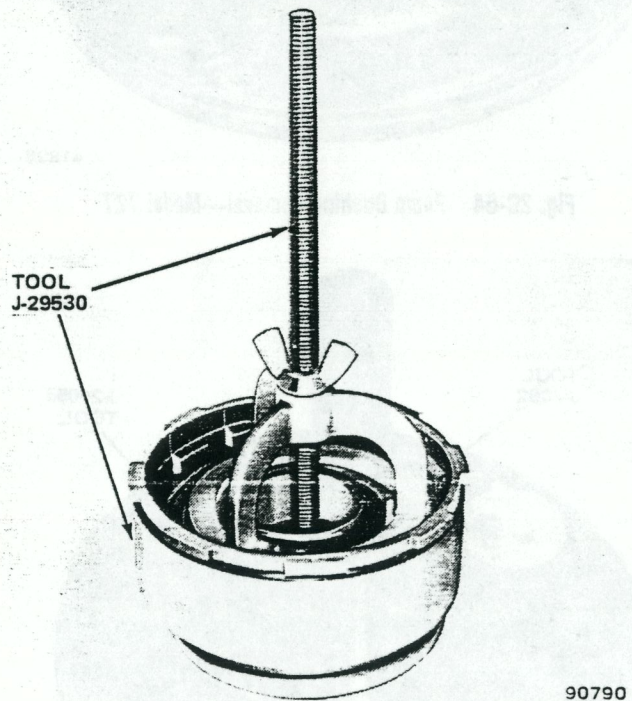

Fig. 2C-69 Front Clutch Snap Ring Removal/Installation—Model 904/999

Inspect the seal ring surfaces inside the clutch retainer for nicks or deep scratches. Light scratches will not interfere with sealing of the rings. Inspect the clutch retainer bushing for scores and wear and inspect the inner bore surface for wear and inspect the inner bore surface for wear from the reaction shaft support seal rings and lands.

Inspect the inside of the piston bore for score marks. Remove light scores with crocus cloth. Inspect the seal ring grooves for nicks and burrs. Inspect the piston spring, retainer, and snap ring for distortion.

**Retainer Bushing Replacement**

- (1) Place clutch retainer, with open end facing down, on a clean, smooth surface.
- (2) Insert Bushing Remover/Installer Tool J-24064 in bushing (fig. 2C-70).
- (3) Install Driver Handle J-8092 in remover tool and drive bushing straight down and out of retainer bore.
- (4) Position clutch retainer so open end faces upward.
- (5) Install replacement bushing on tool and install bushing straight into retainer bore until bushing is flush with base of bore chamfer (fig. 2C-71).

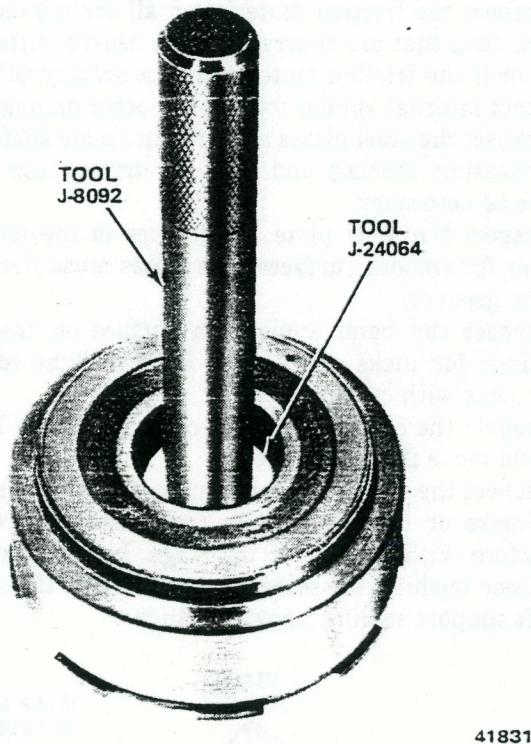

41831  
**Fig. 2C-70 Clutch Retainer Bushing Removal—Model 904/999**

**Assembly**

- (1) Lubricate inner seal with petroleum jelly and install seal on hub of clutch retainer.

**NOTE:** *Be sure the seal lip is facing into the piston bore and that the seal is properly seated in the retainer groove.*

- (2) Lubricate outer seal with petroleum jelly and install it on clutch piston so seal lip faces into piston bore.
- (3) Install piston assembly in retainer using a twisting motion to seat piston at bottom of bore.
- (4) Install spring on piston hub and spring retainer.
- (5) Install snap ring over spring.
- (6) Install Spring Compressor Tool J-5886-01 over retainer assembly.

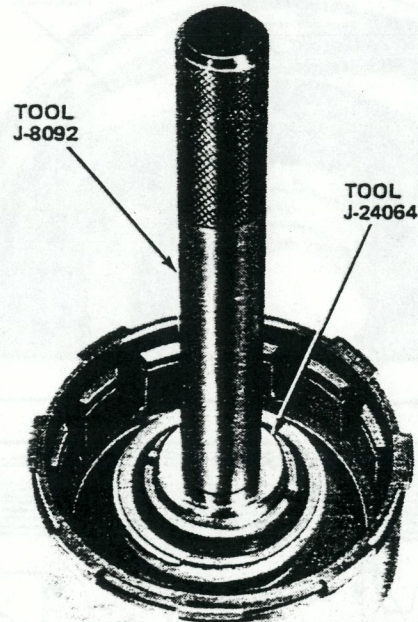

41832  
**Fig. 2C-71 Clutch Retainer Bushing Installation—Model 904/999**

- (7) Compress spring and seat snap ring in clutch hub groove.
- (8) Remove compressor tool.
- (9) Lubricate clutch plates and discs with transmission fluid.
- (10) Install one steel plate followed by a lined plate until proper number of plates are installed.
- (11) Install pressure plate and waved snap ring.

**NOTE:** *Be sure snap ring is completely seated in groove.*

- (12) Measure clutch pack clearance using feeler gauge.
- (13) Insert gauge between pressure plate and snap ring (fig. 2C-72). Refer to Clutch Plate Clearance in Specifications for tolerances.

- (14) If clutch plate clearance is not within specifications, disassemble clutch pack and measure thickness of lined plate, steel plates and pressure plate. Thickness should be as follows:

|                          |                                       |
|--------------------------|---------------------------------------|
| Lined Plate . . . . .    | 0.083 to 0.088 inch (2.11 to 2.24 mm) |
| Steel Plate . . . . .    | 0.066 to 0.071 inch (1.68 to 1.80 mm) |
| Pressure Plate . . . . . | 0.214 to 0.218 inch (5.44 to 5.54 mm) |

Any component not meeting the listed thickness specification must be replaced in order to obtain the correct clutch pack clearance.

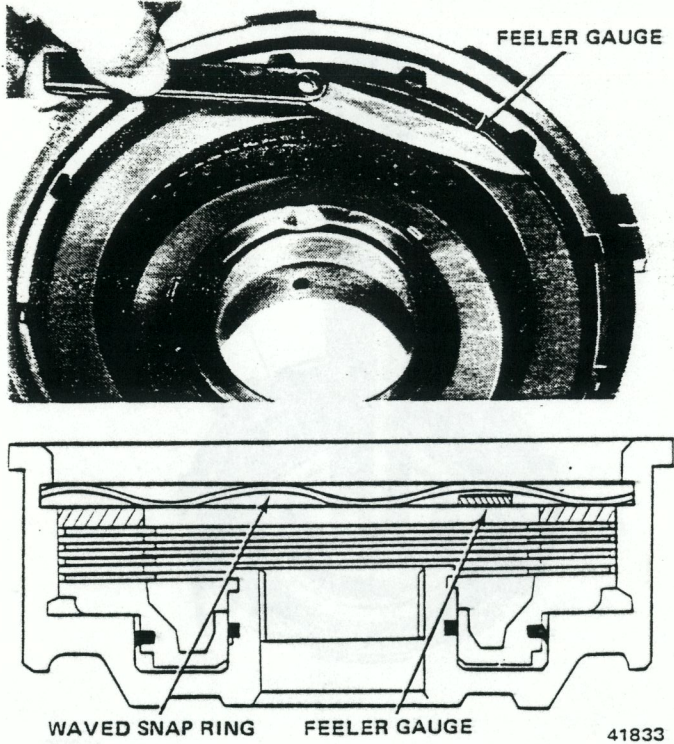

Fig. 2C-72 Measuring Front Clutch Pack Clearance

**Front Clutch—Model 727**

**Disassembly**

- (1) Remove large waved snap ring that retains pressure plate in clutch piston retainer (fig. 2C-73).
- (2) Remove pressure plate and clutch plates.

- (3) Install Compressor Tool J-24042 over piston spring retainer (fig. 2C-74).
- (4) Compress springs and remove snap ring.
- (5) Slowly release compressor tool until spring retainer is free of hub.

**NOTE:** Do not allow the spring retainer to stick or bind in the snap ring groove.

- (6) Remove compressor tool, retainer and springs.
- (7) Turn clutch retainer over and bump on wood block to dislodge and remove piston.
- (8) Remove seals from piston and retainer hub.

**Inspection**

Inspect the friction material on all driving discs. Replace discs that are charred, glazed, heavily pitted, flaking, or if the friction material can be scraped off easily. Inspect internal splines for wear or other damage.

Inspect the steel plates and pressure plate surfaces for overheating, scoring, and damaged driving lugs and replace as necessary.

Inspect the steel plate lug grooves in the clutch retainer for smooth surfaces. The plates must slide freely in the grooves.

Inspect the band application surface on the clutch retainer for nicks and scores. Remove light scratches and nicks with crocus cloth.

Inspect the check ball in the clutch retainer. The ball should move freely in its cage.

Inspect the seal ring surface inside the clutch retainer for nicks or deep scratches. Light scratches will not interfere with sealing of the rings. Inspect the clutch retainer bushing for scores and wear from the reaction shaft support sealing rings and lands.

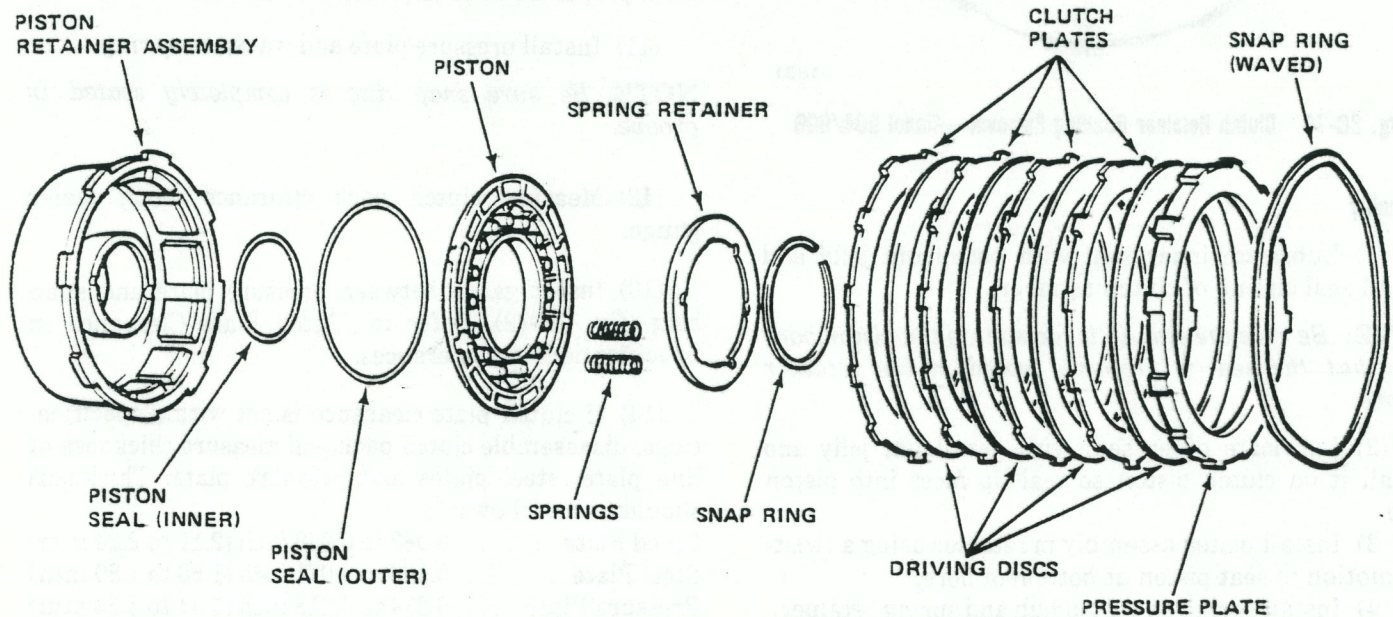
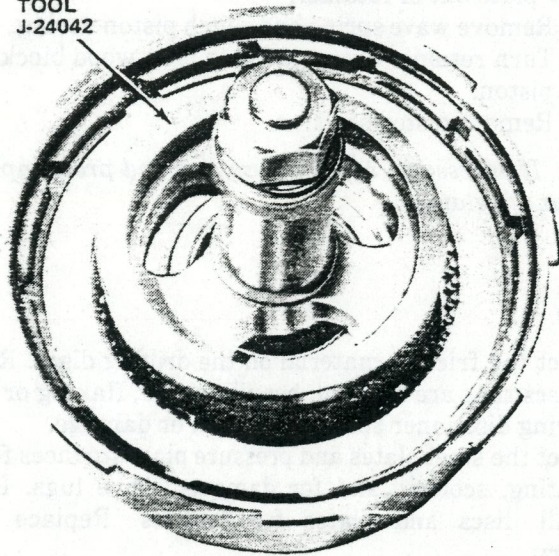

Fig. 2C-73 Front Clutch Assembly—Model 727

TOOL  
J-24042



41834

**Fig. 2C-74 Front Clutch Spring Retainer  
Removal/Installation—Model 727**

Inspect the inner bore of the piston for score marks. Remove light scores with crocus cloth. Inspect the seal ring grooves for nicks and burrs. Inspect the piston springs, retainer, and snap ring for distortion.

**Retainer Bushing Replacement**

(1) Place clutch retainer, with open end facing downward, on clean, smooth surface.

(2) Insert Bushing Remover/Installer Tool J-24309 in bushing (fig. 2C-75).

(3) Install Drive Handle J-8092 in tool and tap bushing straight down and out of bore.

(4) Position clutch retainer so open end faces upward.

(5) Install replacement bushing on Tool J-24039 and install bushing straight into retainer bore until bushing is flush with base of bore chamfer (fig. 2C-76).

**Assembly**

(1) Lubricate inner seal with petroleum jelly and install it on hub of clutch retainer.

**NOTE:** *Be sure the seal lip faces into the piston bore and is properly seated in the seal groove.*

(2) Lubricate outer seal with petroleum jelly and install it on clutch piston with seal lip facing into piston bore.

(3) Install piston assembly in retainer and carefully seat piston at bottom of retainer bore.

(4) Install clutch piston springs on piston (fig. 2C-77). Install nine or eleven springs in clutch (according to original number in clutch).

TOOL  
J-8092

TOOL  
J-24039

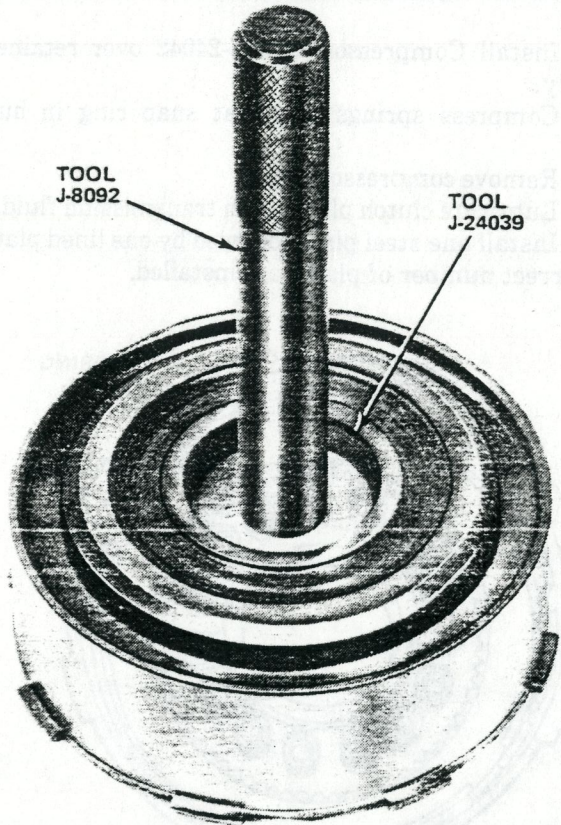

41835

**Fig. 2C-75 Front Clutch Retainer Bushing Removal—Model 727**

TOOL  
J-8092

TOOL  
J-24039

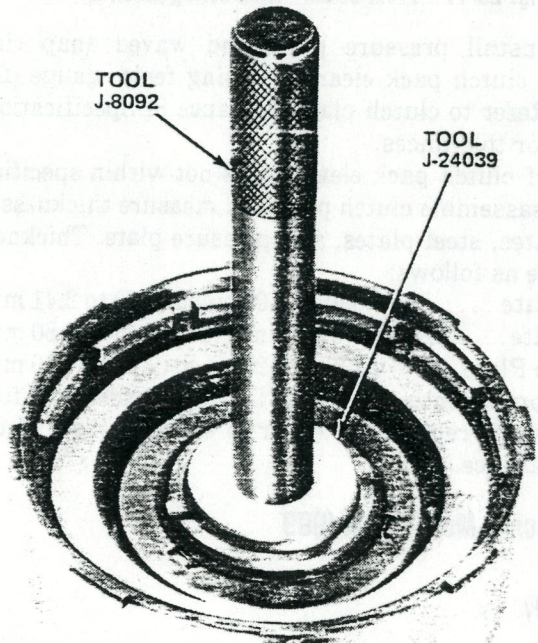

41836

**Fig. 2C-76 Front Clutch Retainer Bushing Installation—Model 727**

- (5) Install spring retainer and snap ring over springs.
- (6) Install Compressor Tool J-24042 over retainer assembly.
- (7) Compress springs and seat snap ring in hub groove.
- (8) Remove compressor tool.
- (9) Lubricate clutch plates with transmission fluid.
- (10) Install one steel plate followed by one lined plate until correct number of plates are installed.

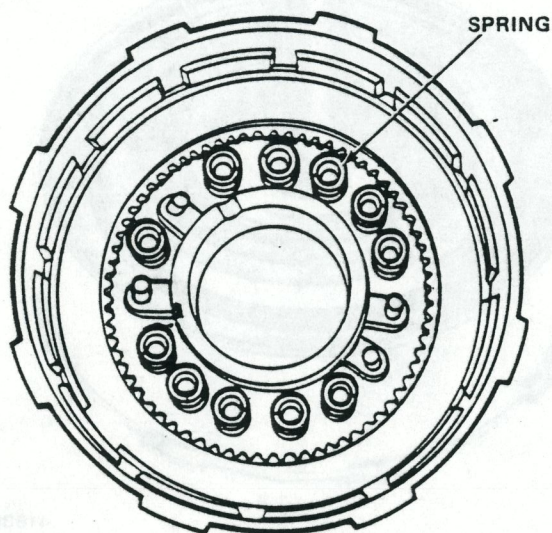

41837

Fig. 2C-77 Front Clutch Piston Spring Location

(11) Install pressure plate and waved snap ring. Measure clutch pack clearance using feeler gauge (fig. 2C-72). Refer to clutch plate clearance in Specifications section for tolerances.

(12) If clutch pack clearance is not within specifications, disassemble clutch pack and measure thickness of lined plates, steel plates, and pressure plate. Thickness should be as follows:

|                          |  |
|--------------------------|--|
| Lined Plate . . . . .    | 0.090 to 0.095-inch (2.29 to 2.41 mm)    |
| Steel Plate . . . . .    | 0.060 to 0.071 inch (1.52 mm to 1.80 mm) |
| Pressure Plate . . . . . | 0.278 to 0.282 inch (7.06 to 7.16 mm)    |

Any component not meeting listed thickness specification must be replaced in order to obtain correct clutch pack clearance.

### Rear Clutch—Models 904/999

#### Disassembly

(1) Remove large snap ring that retains pressure plate in clutch piston retainer (fig. 2C-78).

**NOTE:** This is a selective thickness snap ring and determines clutch pack clearance.

- (2) Lift pressure plate, clutch plates, and inner pressure plate out of retainer.
- (3) Remove wave spring and clutch piston spring.
- (4) Turn retainer over and bump it on wood block to remove piston.
- (5) Remove piston seals.

**NOTE:** If necessary, remove snap ring and press input shaft out of retainer.

#### Inspection

Inspect the friction material on the driving discs. Replace discs that are charred, heavily pitted, flaking or if the driving disc inner splines are worn or damaged.

Inspect the steel plates and pressure plate surfaces for overheating, scoring, and for damaged drive lugs. Inspect all discs and plates for flatness. Replace if necessary.

Inspect the steel plate lug grooves in the clutch retainer for smooth surfaces. The plates must slide freely in these grooves. Inspect the clutch piston ball check. The ball should move freely in its cage. Inspect the seal ring surfaces in the clutch retainer for nicks or deep scratches. Light scratches will not interfere with sealing. Inspect the piston spring and wave spring for distortion or breakage.

Inspect the seal ring grooves in the input shaft and piston retainer for nicks, burrs, and wear.

Inspect the rear clutch to front clutch thrust washer. The washer should be 0.043 to 0.045 inch (1.09 to 1.14 mm) thick.

#### Assembly

- (1) Press input shaft into piston retainer (if removed) and install snap ring.
- (2) Lubricate and install inner and outer seal rings on clutch piston.

**NOTE:** Be sure that the lips of the seals face into the retainer bore and that the seals are properly seated in the piston grooves.

(3) Install piston assembly into retainer using a twisting motion to seat piston at bottom of retainer bore. Install piston spring in retainer with spring fingers touching piston and with spring centered in retainer.

(4) Install one end of wave spring into retainer groove (fig. 2C-79) and progressively push or tap spring into place until completely seated. If necessary, lightly tap piston spring to keep it centered.

(5) Install inner pressure plate. Raised side of plate should rest on piston spring and flat surface should face open end of retainer.

(6) Lubricate clutch plates with transmission fluid.

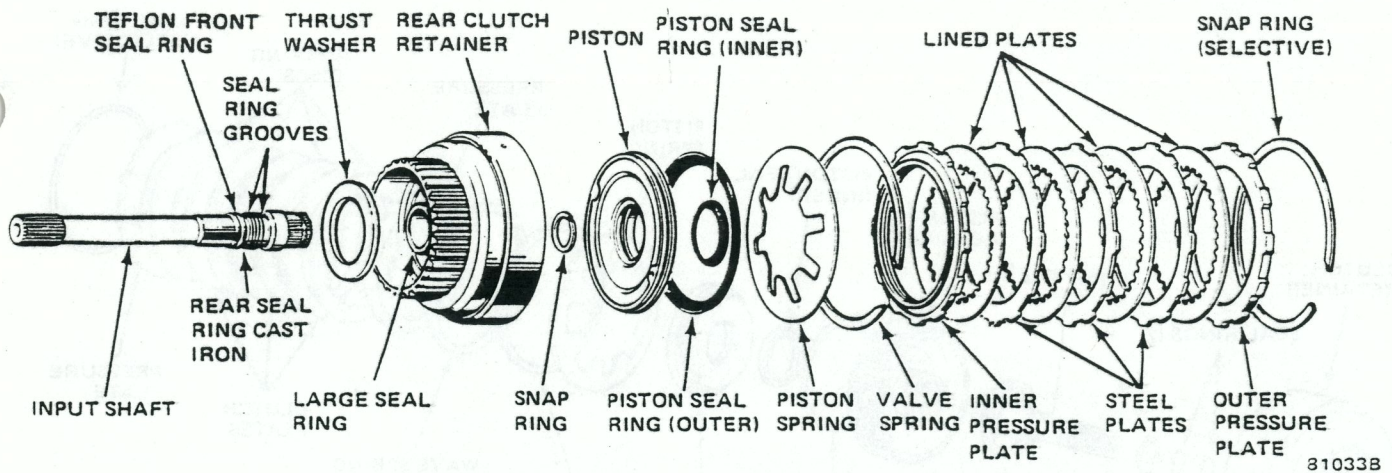

Fig. 2C-78 Rear Clutch Assembly—Models 904/999

(7) Install a lined plate first and follow with a steel plate and a lined plate until correct number of plates are installed.

(8) Install outer pressure plate and selective thickness snap ring.

(9) Measure rear clutch pack clearance. Press down firmly on outer pressure plate and insert feeler gauge between pressure plate and selective snap ring (fig. 2C-80).

(10) If necessary, adjust clearance using one of the following selective thickness outer snap rings. Snap rings are available in 0.060, 0.076 and 0.098-inch (1.52, .93 and 2.49 mm) thicknesses. Low limit clearance is desirable.

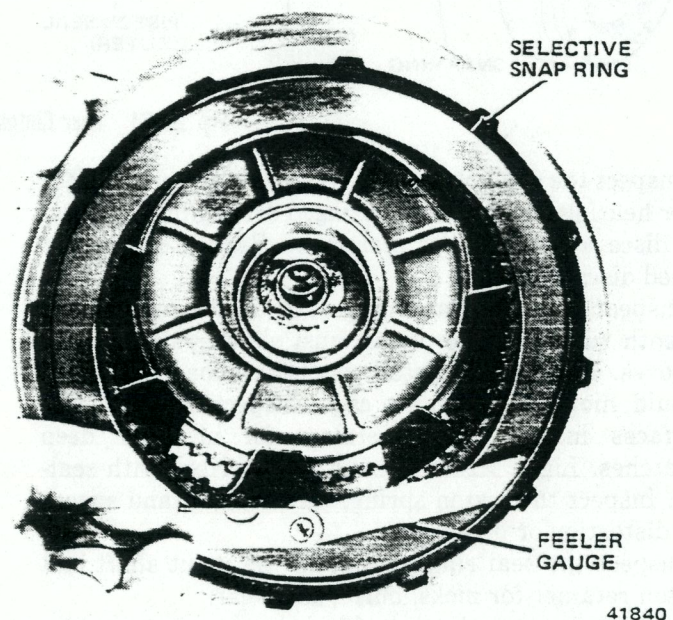

Fig. 2C-80 Measuring Rear Clutch Pack Clearance

**NOTE:** This is a selective thickness snap ring and determines clutch pack clearance.

(2) Remove pressure plate, clutch plates, and inner pressure plate.

(3) Remove wave spring, spacer ring, and clutch piston spring.

(4) Turn retainer over and bump on wood block to remove piston.

(5) Remove piston inner and outer seals.

(6) Remove input shaft snap ring and press input shaft out of retainer, if necessary.

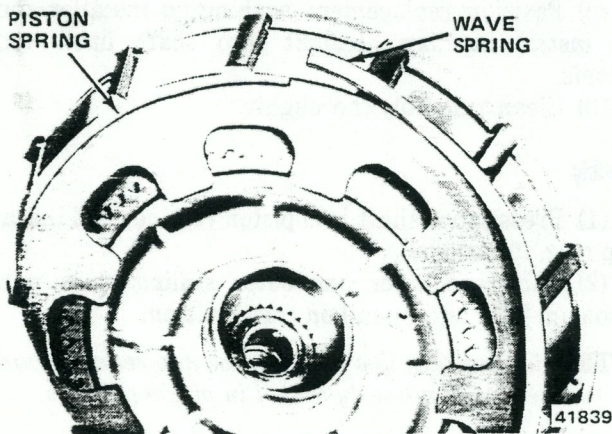

Fig. 2C-79 Piston Spring and Wave Spring Installation

**NOTE:** Rear clutch pack clearance is very important in obtaining proper clutch engagement and shift quality.

### Rear Clutch—Model 727

#### Disassembly

(1) Remove large snap ring that retains pressure plate in clutch piston retainer (fig. 2C-81).

#### Inspection

Inspect friction material on driving discs. Replace discs that are charred, glazed, heavily pitted, flaking or if the friction material can be scraped off easily. Inspect the driving disc inner splines for wear or other damage.

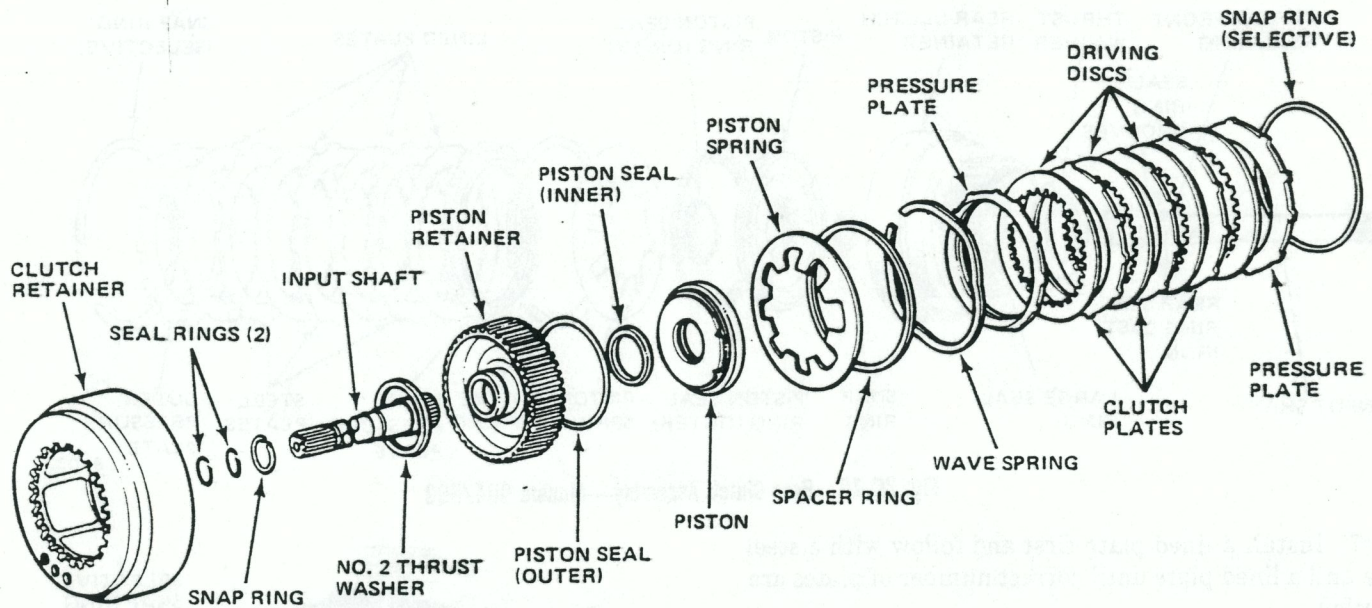

80015

Fig. 2C-81 Rear Clutch Assembly—Model 727

Inspect the steel plates and pressure plate surfaces for over heating, scoring, and damaged driving lugs. Inspect all discs and plates for distortion. Replace warped or coned discs or plates.

Inspect the steel plate lug grooves in the retainer for smooth surfaces. The plates must slide freely in these grooves. Inspect the clutch piston ball check. The ball should move freely in its cage. Inspect the seal ring surfaces in the clutch retainer for nicks or deep scratches. Light scratches will not interfere with sealing. Inspect the piston spring, wave spring, and spacer for distortion or breakage.

Inspect the seal ring grooves in the input shaft and piston retainer for nicks, burrs, and wear.

Inspect the rear clutch to front clutch thrust washer. The washer should be 0.061 to 0.063-inches (1.55 to 1.60 mm) thick.

#### Input Shaft Bushing Replacement

(1) Clamp input shaft in a vise using brass protective jaws.

**CAUTION:** Do not clamp the seal ring land or bearing journal.

(2) Thread Bushing Remover Tool J-24041 straight into bushing as far as possible by hand.

(3) Using wrench, thread puller into bushing three to four additional turns to fully engage puller threads in bushing.

(4) Thread Slide Hammer Bolts Tool J-7004-3 into puller (fig. 2C-82).

(5) Bump outward with slide hammers to remove bushing.

(6) Thoroughly clean input shaft and remove chips generated by bushing removal.

(7) Grip old bushing with pliers and remove it from tool.

**NOTE:** Be careful to protect the remover tool threads when using the tool.

(8) Thread Bushing Installer Tool J-24040 onto Driver Handle J-8092 (fig. 2C-83).

(9) Position replacement bushing on installer tool and install bushing straight into shaft until tool bottoms.

(10) Clean assembly thoroughly.

#### Assembly

(1) Press input shaft into piston retainer and install snap ring, if removed.

(2) Lubricate inner and outer sealing rings with petroleum jelly and install on clutch piston.

**NOTE:** Be sure that lips of seals face into retainer bore and that seals are properly seated in piston grooves.

(3) Install piston assembly in clutch retainer.

(4) Seat piston at bottom of retainer bore using a twisting motion.

(5) Position clutch retainer over piston retainer splines. Support assembly to maintain position of clutch retainer.

(6) Install piston spring in clutch retainer with spring fingers touching piston.

(7) Install spacer ring. Be sure piston spring and ring are centered in retainer recess.

(8) Install one end of wave spring in retainer groove. Progressively push or tap spring into plate until completely seated.



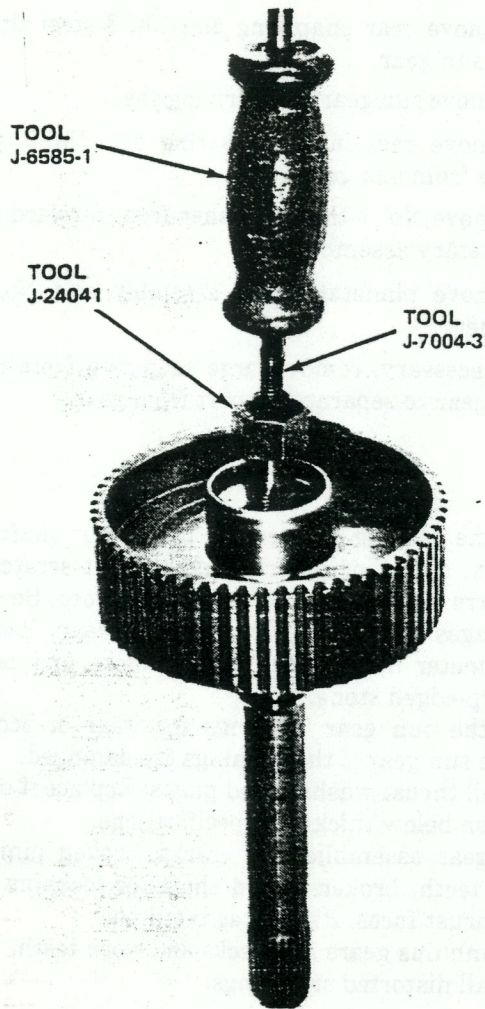

41842

Fig. 2C-82 Input Shaft Bushing Removal—Model 727

**NOTE:** If necessary, gently tap the piston spring and spacer to keep them centered.

(9) Install inner pressure plate in retainer. Raised side of plate should rest on piston spring and flat surface should face outward.

(10) Lubricate remaining clutch plates with transmission fluid and install in retainer. Alternately install lined plate followed by steel plate until correct number of lined and steel plates have been installed.

(11) Install outer pressure plate and selective thickness snap ring.

(12) Measure clutch pack clearance. Press down firmly on outer pressure plate and insert a feeler gauge between pressure plate and selective outer snap spring.

(13) If necessary, adjust clearance using one of the following selective thickness snap rings. Snap rings are available in 0.060, 0.074, 0.088 and 0.106-inch (1.52, 1.88 and 2.70 mm) thicknesses.

**NOTE:** Rear clutch pack clearance is very important in obtaining proper clutch engagement and shift quality.

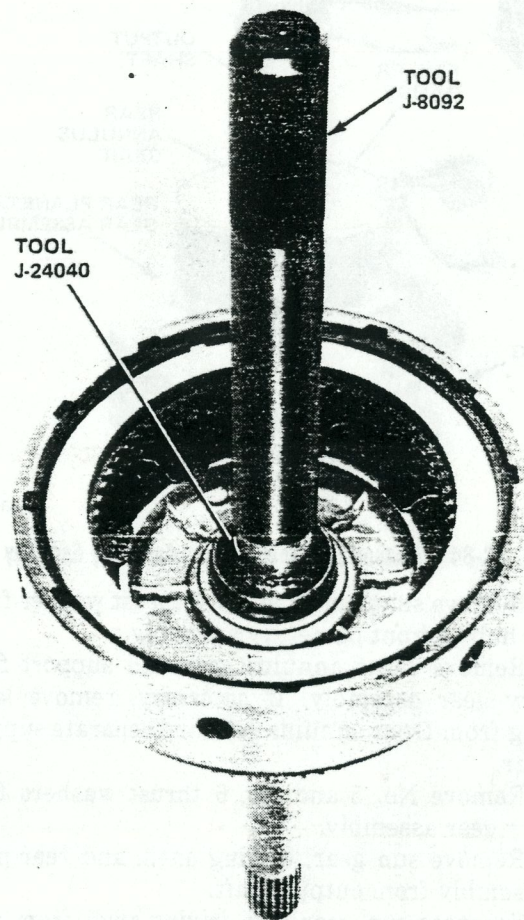

41843

Fig. 2C-83 Input Shaft Bushing Installation—Model 727

### Planetary Gear Assembly—Models 904/999

#### End Play Measurement

(1) Measure end play of planetary assembly before removing component parts from output shaft.

(2) Support front end of output shaft on wood block and position assembly in an upright position.

(3) Push rear annulus gear support downward on output shaft (fig. 2C-84).

(4) Insert feeler gauge between rear annulus support and shoulder on output shaft. Clearance should be 0.001 to 0.047 inch (0.02 to 1.19 mm). If clearance is not within specifications, replace thrust washers, any worn parts, and selective thickness snap ring at assembly.

#### Disassembly

(1) Remove No. 3 thrust washer from forward end of output shaft (figs. 2C-85 and 2C-86).

(2) Remove selective snap ring from forward end of output shaft.

(3) Remove front planetary gear assembly.

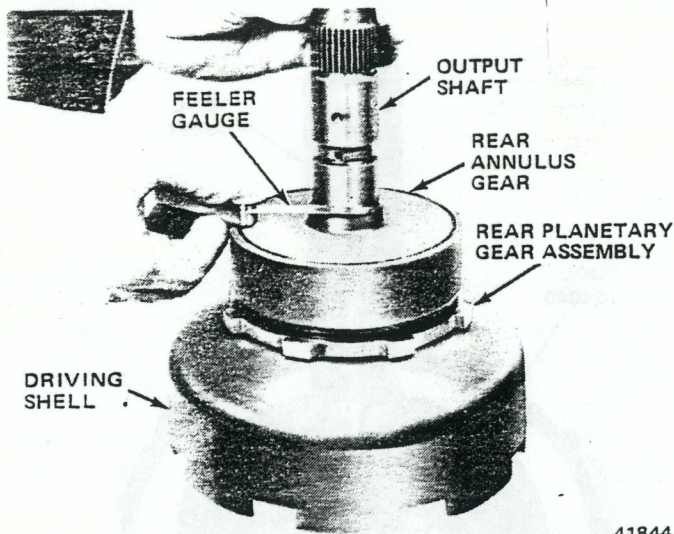

41844

Fig. 2C-84 Measuring Planetary Gear Assembly End Play

- (4) Remove snap ring and No. 4 thrust washer from forward hub of front planetary assembly.
- (5) Remove front annulus gear and support from planetary gear assembly. If necessary, remove large snap ring from front annulus gear and separate support from gear.
- (6) Remove No. 5 and No. 6 thrust washers from planetary gear assembly.
- (7) Remove sun gear, driving shell, and rear planetary assembly from output shaft.
- (8) Separate sun gear and driving shell from rear planetary assembly.

- (9) Remove rear snap ring and No. 8 steel thrust plate from sun gear.
- (10) Remove sun gear from driving shell.
- (11) Remove remaining snap ring and No. 7 steel thrust plate from sun gear.
- (12) Remove No. 9 thrust washer from forward side of rear planetary assembly.
- (13) Remove planetary gear assembly and No. 10 thrust washer.
- (14) If necessary, remove large snap ring from rear of annulus gear to separate support from gear.

**Inspection**

Inspect the bearing surfaces on the output shaft for nicks, burrs, scores or other damage. Light scratches, nicks or burrs can be removed with crocus cloth. Be sure all oil passages in the shaft are open and clean. Inspect the speedometer drive gear. Remove nicks and burrs with a sharp-edged stone.

Inspect the sun gear bushings for wear or scores. Replace the sun gear if the bushings are damaged.

Inspect all thrust washers and plates. Replace if damaged or worn below thickness specifications.

Inspect gear assemblies for cracks, broken pinions, worn gear teeth, broken pinion shafts or lockpins and damaged thrust faces. Replace as required.

Inspect annulus gears for cracks and worn teeth. Replace all distorted snap rings.

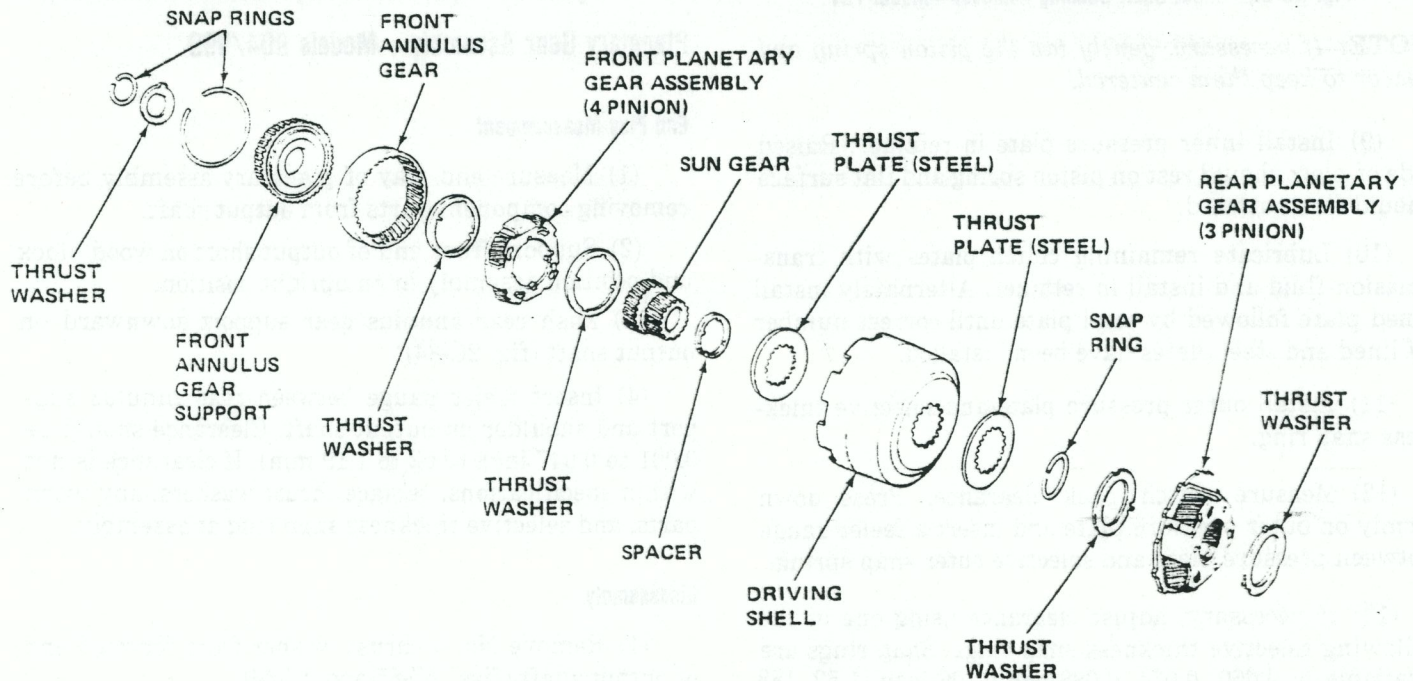
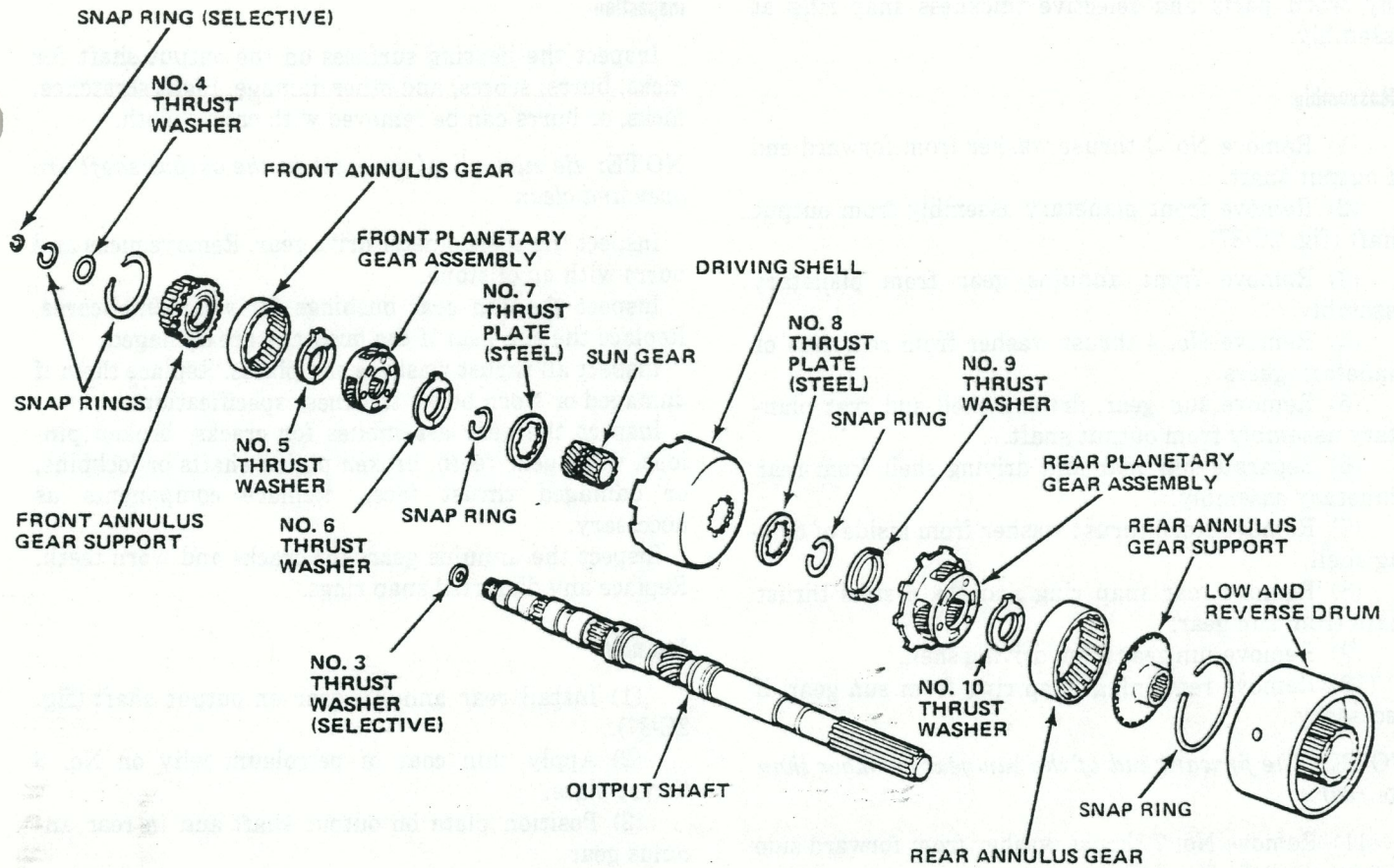

Fig. 2C-85 Planetary Gear Assembly—Model 904



60174

Fig. 2C-86 Planetary Gear Assembly—Model 999

**Assembly**

- (1) Install rear annulus gear support in annulus gear and install snap ring.
- (2) Install rear annulus gear assembly on output shaft.
- (3) Install No. 10 thrust washer on output shaft.
- (4) Position rear planetary gear assembly in rear annulus gear. Install No. 9 thrust washer on front side of gear assembly.
- (5) Install No. 7 steel thrust plate and snap ring on opposite end of sun gear.
- (6) Insert sun gear through front side of driving shell, and install No. 8 steel thrust plate and snap ring on one end of sun gear.
- (7) Install driving shell and sun gear onto output shaft, and engage sun gear teeth with rear planetary pinions.
- (8) Install front annulus gear support in annulus gear and install large snap ring.
- (9) Install No. 5 thrust at forward end of front planetary gear assembly, and insert assembly into front annulus gear.
- (10) Position No. 6 thrust washer on rear side of front planetary gear assembly.

- (11) Carefully work front planetary and annulus gear assembly onto output shaft and mesh planetary pinions with sun gear.
- (12) Install No. 3 thrust washer on output shaft.
- (13) Install selective snap ring and measure assembly end play.

**NOTE:** *If necessary, adjust clearance by using selective thickness snap rings. Snap rings are available in 0.042, 0.064 and 0.084-inch (1.06, 1.63 and 2.13 mm) thicknesses.*

**Planetary Gear Assembly—Model 727**

**End Play Measurement**

- (1) Measure planetary assembly end play before removing component parts from output shaft.
- (2) Support front end of output shaft on wood block and place assembly in upright position.
- (3) Push rear annulus gear support downward on output shaft.
- (4) Insert feeler gauge between rear annulus support and shoulder on output shaft (fig. 2C-84). Clearance should be 0.009 to 0.0044-inch (0.22 to 1.12 mm). If clearance is not within specifications, replace thrust washers.

any worn parts and selective thickness snap ring at assembly.

### Disassembly

(1) Remove No. 3 thrust washer from forward end of output shaft.

(2) Remove front planetary assembly from output shaft (fig. 2C-87).

(3) Remove front annulus gear from planetary assembly.

(4) Remove No. 4 thrust washer from rear side of planetary gears.

(5) Remove sun gear, driving shell and rear planetary assembly from output shaft.

(6) Separate sun gear and driving shell from rear planetary assembly.

(7) Remove No. 5 thrust washer from inside of driving shell.

(8) Remove rear snap ring and No. 6 steel thrust plate from sun gear.

(9) Remove sun gear from driving shell.

(10) Remove remaining snap ring from sun gear, if necessary.

**NOTE:** *The forward end of the sun gear is longer than the rear.*

(11) Remove No. 7 thrust washer from forward side of rear planetary assembly.

(12) Remove gear assembly and No. 8 thrust plate from rear annulus gear.

### Inspection

Inspect the bearing surfaces on the output shaft for nicks, burrs, scores, and other damage. Light scratches, nicks, or burrs can be removed with crocus cloth.

**NOTE:** *Be sure all oil passages in the output shaft are open and clean.*

Inspect the speedometer drive gear. Remove nicks and burrs with an oilstone.

Inspect the sun gear bushings for wear and scores. Replace the sun gear if the bushings are damaged.

Inspect all thrust washers and plates. Replace them if damaged or worn below thickness specifications.

Inspect the gear assemblies for cracks, broken pinions, worn gear teeth, broken pinion shafts or lockpins, or damaged thrust faces. Replace components as necessary.

Inspect the annulus gears for cracks and worn teeth. Replace any distorted snap rings.

### Assembly

(1) Install rear annulus gear on output shaft (fig. 2C-87).

(2) Apply thin coat of petroleum jelly on No. 8 thrust plate.

(3) Position plate on output shaft and in rear annulus gear.

**NOTE:** *Be sure teeth are engaged with output shaft splines.*

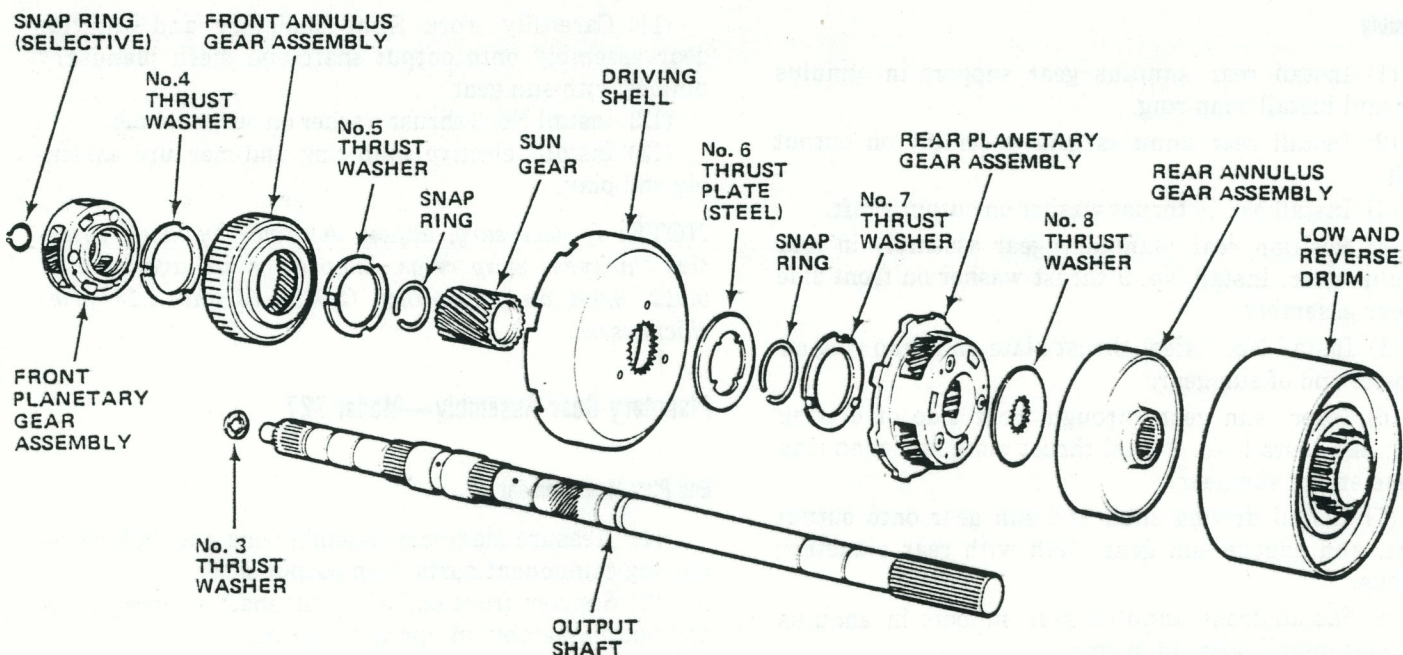

Fig. 2C-87 Planetary Gear Assembly—Model 727

(4) Position rear planetary gear assembly in rear annulus gear and install No. 7 thrust washer on forward side of gear assembly.

(5) Install snap ring in forward groove of sun gear (long end of gear).

(6) Insert sun gear through forward side of driving shell and install steel thrust plate and snap ring on rear side of sun gear.

(7) Install snap ring in forward groove of sun gear. Install No. 5 thrust washer in driving shell over sun gear.

(8) Install driving shell and sun gear assembly on output shaft and engage sun gear teeth with rear planetary pinions.

(9) Position No. 4 thrust washer on rear hub of front planetary gear and engage planetary gear with front annulus gear.

(10) Install front planetary and annulus gear assembly onto output shaft and mesh planetary pinions with sun gear.

(11) Install selective snap ring and measure assembly end play.

**NOTE:** If necessary, the clearance should be adjusted by using selective thickness snap rings. Snap rings are available in 0.048, 0.055 and 0.062-inch (1.22, 1.40 and 1.57 mm) thicknesses.

### Overrunning Clutch

#### Inspection

Inspect the clutch rollers for smooth, round surfaces. They must be free of flat spots and chipped teeth.

Inspect the roller contact surfaces in the cam and race for brinelling and inspect the springs for distortion, wear or other damage.

On model 727 transmission only, inspect the cam setscrew for tightness. If loose, tighten the setscrew and restake the case around the screw.

#### Cam Replacement—Model 999

If the overrunning clutch cam or spring retainer are damaged, they can be replaced with a service replacement cam, spring retainer and retaining screw (fig. 2C-88).

(1) Remove bolts attaching output shaft support to rear of case.

(2) Remove support from rear of case using wood-block and hammer.

(3) Centerpunch rivets exactly in center of each rivet head (fig. 2C-89).

(4) Drill through each rivet head using 3/8-inch (10 mm) diameter drill.

**CAUTION:** Do not drill into the transmission case.

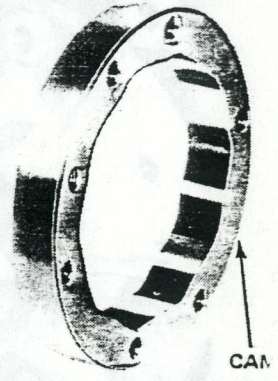

Fig. 2C-88

(5) Remove rivet head

(6) Remove rivets

punch (fig. 2C-90).  
**NOTE:** Move punch from  
wise direction after each  
out of the case evenly.

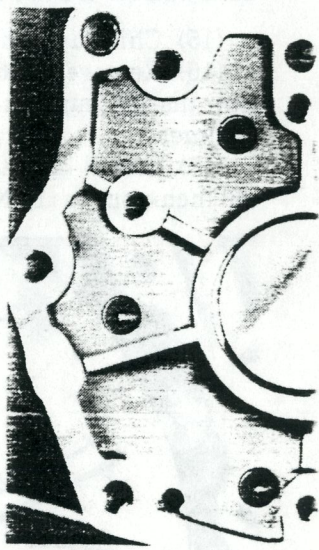

Fig. 2C-89

(7) Enlarge rivet hole

eter 17/64-inch (7 mm) di

(8) Remove chips, be  
from case and be sure o  
chips.

(9) Install replacement  
case with bolt holes in  
holes in case.

(10) Thread retaining

**NOTE:** Install the wash  
inner diameter of the was

(11) Install cam in case

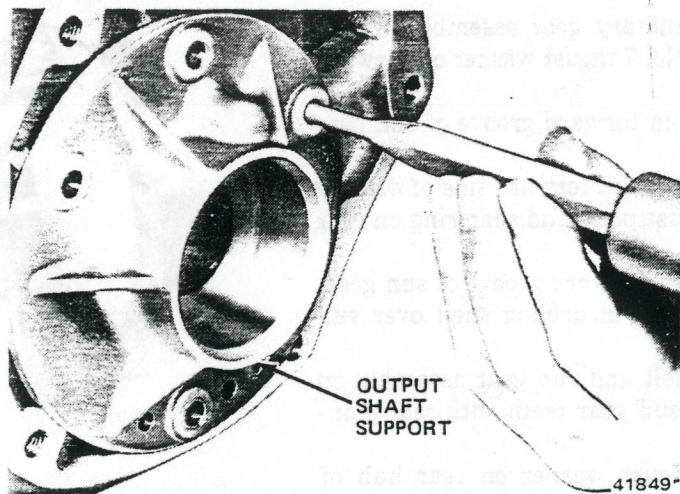

**Fig. 2C-90** Overrunning Clutch Cam Removal

(12) Alternately and evenly tighten retaining screws to 100 inch-pounds (11 N•m) torque.

(13) Thread two Pilot Studs Tool J-3387-2 into case (fig. 2C-91).

(14) Position illuminated light bulb next to case to heat case.

**CAUTION:** Do not use an open flame to heat the case.

(15) Chill support with ice (preferably dry ice).

(16) Remove light, position support over pilot studs and install support in case using wood block and hammer.

(17) Install and tighten support attaching bolts to 150 inch-pounds (17 N•m) torque.

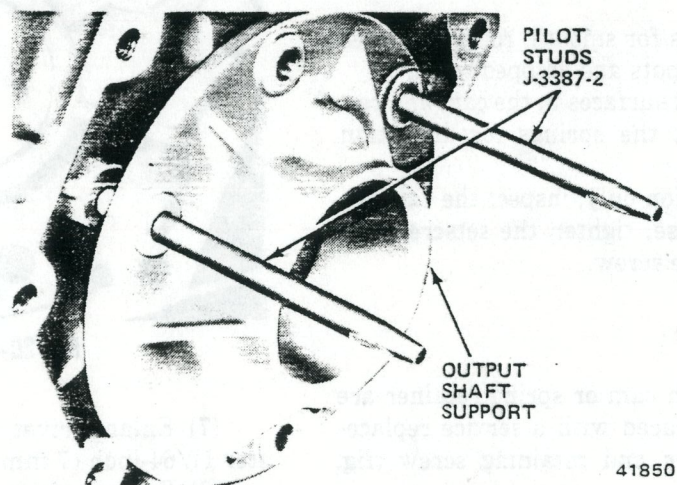

**Fig. 2C-91** Output Shaft Support Alignment

#### Cam Replacement—Model 727

The overrunning clutch cam and spring retainer should be removed only if replacement is necessary.

(1) Remove setscrew from case.

(2) Remove bolts attaching output shaft support to rear of case.

(3) Insert punch through bolt holes and drive cam out of case (fig. 2C-90).

**NOTE:** Move punch from one bolt hole to another in clockwise direction after each punch stroke to drive the cam out of the case evenly.

**CAUTION:** The output shaft support must be installed in the case before the overrunning clutch cam can be installed. If the support must be replaced drive it out the rear of the case using a wood block and hammer.

(4) Thread two Pilot Stud Tools J-3387-2 into case (fig. 2C-91).

(5) Install support in case using wood block and hammer.

(6) Clean all burrs, chips, and foreign material from cam area in case.

(7) Position spring retainer on cam. Be sure retainer lugs snap firmly into cam notch.

(8) Align cam serrations with those in case.

(9) Install cam evenly into case as far as possible using brass hammer.

(10) Install Tool J-24042 (fig. 2C-92).

(11) Tighten tool nut to seat cam in case. Be sure cam is completely seated.

(12) Install cam retaining setscrew and stake case around setscrew.

(13) Remove Tool J-24042.

(14) Install and tighten support retaining bolts to 150 inch-pounds (17 N•m) torque.

(15) Stake case around cam in twelve places using blunt chisel.

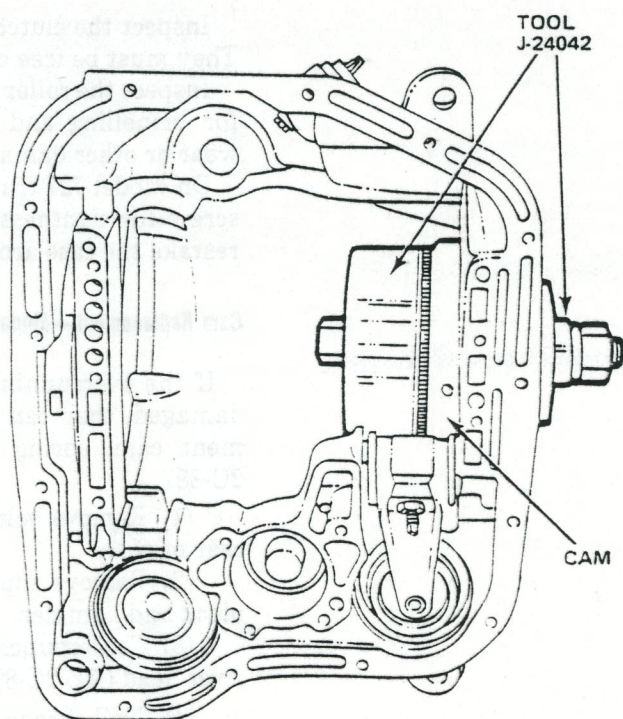

**Fig. 2C-92** Overrunning Clutch Cam Installation—Model 727

### Front Servo and Band

Two front servo designs are used. Refer to figures 2C-93 and 2C-94 for assembly details.

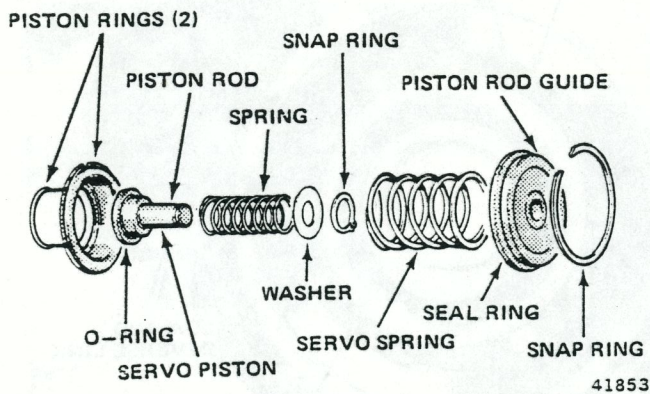

Fig. 2C-93 Kickdown Servo Front Servo Assembly

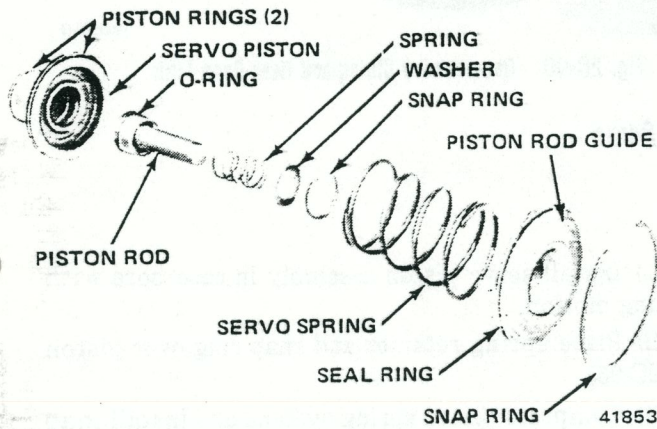

Fig. 2C-94 Front Servo Assembly—Model 727

#### Disassembly

**NOTE:** The front servo in model 727 transmissions requires further disassembly after removal from the servo bore (fig. 2C-93).

- (1) Remove piston rod retaining snap ring from servo piston.
- (2) Remove washer, piston rod spring, and piston rod from servo piston.

#### Inspection

Inspect the piston for nicks, burrs, scores, and wear. Be sure the ring grooves are not damaged. Inspect the fit of the guide on the piston rod. Inspect the piston bore in the case for scores or other damage. Inspect the piston spring(s) for distortion. On model 727 transmissions, inspect the bore in the piston and the piston rod O-ring (fig. 2C-94).

Inspect the band lining for a poor bond to the band, burn marks, glazing, uneven wear pattern and flaking.

If the lining is so badly worn that the grooves are not visible at any portion of the band, replace the band. Inspect the band for distortion or cracked ends. Replace as necessary.

#### Assembly

**CAUTION:** Do not use force to assemble any of the servo components. If they do not assemble easily, investigate and correct the cause before proceeding with assembly.

- (1) Apply petroleum jelly to piston rod O-ring and install piston rod in servo piston bore.
- (2) Install piston rod spring on piston rod.
- (3) Install washer.
- (4) Compress spring and install piston rod retaining snap ring.

### Rear Servo and Rear Band

#### Disassembly

- (1) Compress piston plug spring and remove snap ring.
- (2) Remove snap ring, piston plug, and plug spring (fig. 2C-95).

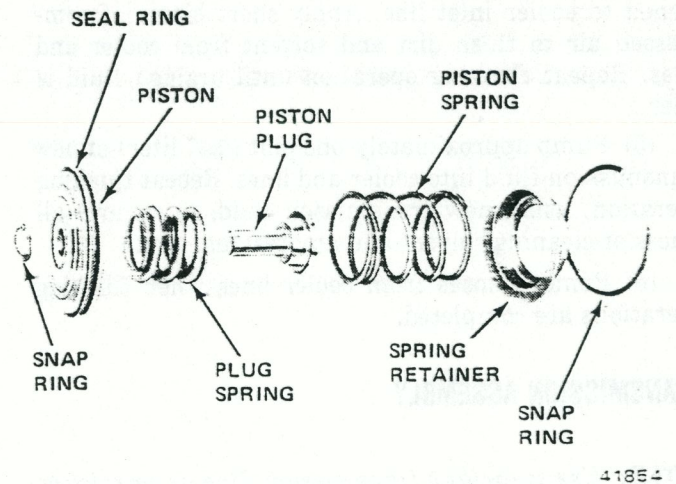

Fig. 2C-95 Rear Servo Assembly

#### Inspection

Inspect the piston and piston plug for nicks, burrs, scores, and wear. The plug must move freely in the piston. Inspect the piston bore in the case for scores or other damage. Inspect the springs for distortion.

Inspect the band lining for poor bonding to the band and for excessive wear. If the lining is so excessively worn that the grooves are not visible at any portion of the band, replace the band. Inspect the band for distortion or cracks and replace as necessary.

**Assembly**

- (1) Lubricate piston plug and piston with petroleum jelly and insert piston plug through plug spring and into piston.
- (2) Compress piston spring and install snap ring.

**Torque Converter Service**

If the transmission is being overhauled to correct a malfunction that generated sludge or heavy accumulations of metal particles or friction material, the oil cooler and cooler lines must be flushed thoroughly and the torque converter replaced. Do not attempt to clean or flush the converter.

The oil cooler and cooler lines can be flushed using solvent and compressed air.

**Flushing Oil Cooler and Cooler Lines**

- (1) Place length of hose over cooler outlet line and secure end of hose in waste container.
- (2) Place length of hose over cooler inlet line.
- (3) Pump approximately one pint (0.47 liter) cleaning solvent into oil cooler through hose attached to inlet line.
- (4) Insert compressed air gun nozzle into hose attached to cooler inlet line. Apply short blasts of compressed air to flush dirt and solvent from cooler and lines. Repeat flushing operation until drained fluid is clear.
- (5) Pump approximately one pint (0.47 liter) of new transmission fluid into cooler and lines. Repeat flushing operation, using new transmission fluid, to remove all traces of cleaning solvent and any residual dirt.
- (6) Remove hoses from cooler lines when flushing operations are completed.

**TRANSMISSION ASSEMBLY**

**NOTE:** Use automatic transmission fluid or petroleum jelly only to lubricate transmission components during assembly.

**Overrunning Clutch**

- (1) Place transmission case in upright position and install clutch cam and spring retainer.
- (2) Install clutch springs and rollers so springs rest against retainer post and rollers rest against springs, and with both springs and rollers installed on counter-clockwise side of spring retainer posts (fig. 2C-96).

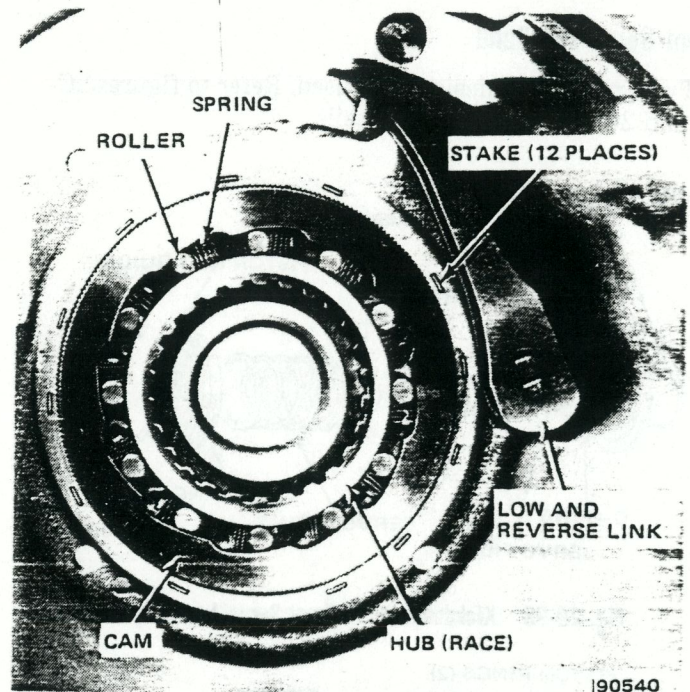

Fig. 2C-96 Overrunning Clutch and Rear Band Link

**Rear Servo**

**Servo**

- (1) Install servo piston assembly in case bore with twisting motion.
- (2) Place spring retainer and snap ring over piston (fig. 2C-95).
- (3) Compress piston spring by hand and install snap ring.

**Rear Band—Model 727**

- (1) Install rear band in case.
- (2) Install short strut, and connect long link and anchor in band (fig. 2C-97).
- (3) Thread band adjusting screw inward just enough to hold band strut in place.
- (4) Be sure long link and anchor assembly is installed as shown in figure 2C-90 to provide clearance for rear band and drum.
- (5) Install low-reverse drum in overrunning clutch hub and rear band.

**Rear Band—Model 904/999**

**NOTE:** Model 904 has a single wrap band. Model 999 transmission has a double wrap band supported at two points by a reaction pin mounted in the case. It is actuated at one point by the rear servo adjusting screw (fig. 2C-98).



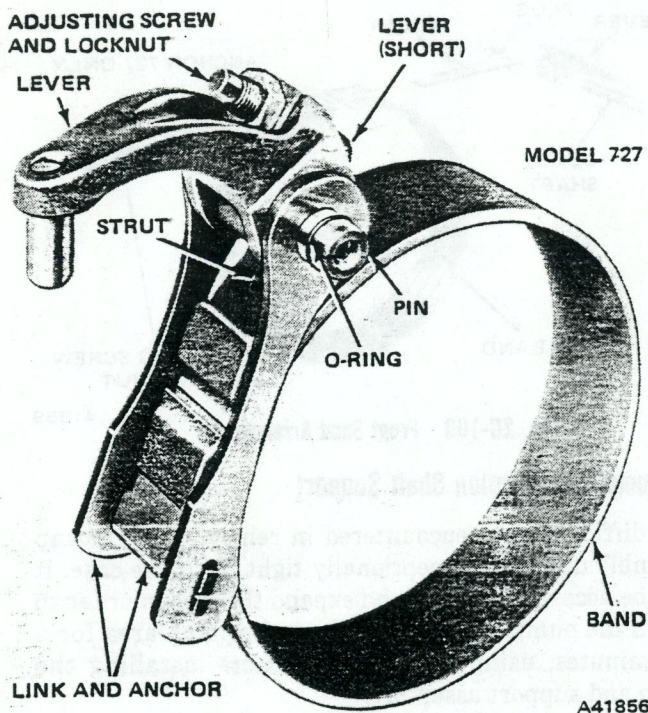

Fig. 2C-97 Rear Band—Model 727

- (1) Install replacement O-ring on reaction pin and insert pin into case until pin is flush with gasket surface.
- (2) Position band in case so both band lugs rest against reaction pin.
- (3) Install low-reverse drum in overrunning clutch hub and into rear band.
- (4) Install band operating lever and pivot pin.

**NOTE:** When installed, the lever adjusting screw should touch the center lug of the band and the pivot pin should be flush with the case (fig. 2C-99).

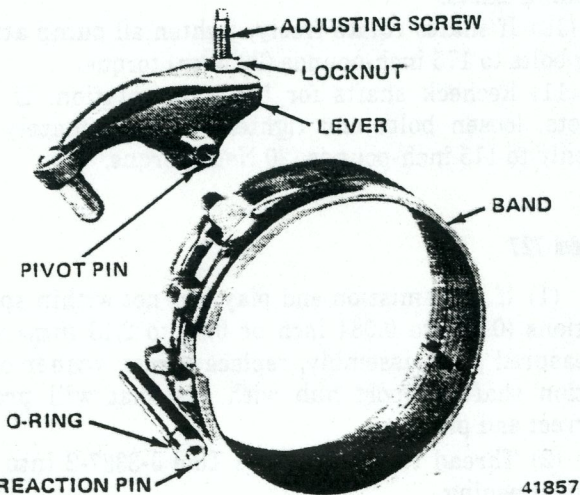

Fig. 2C-98 Rear Band—Model 999

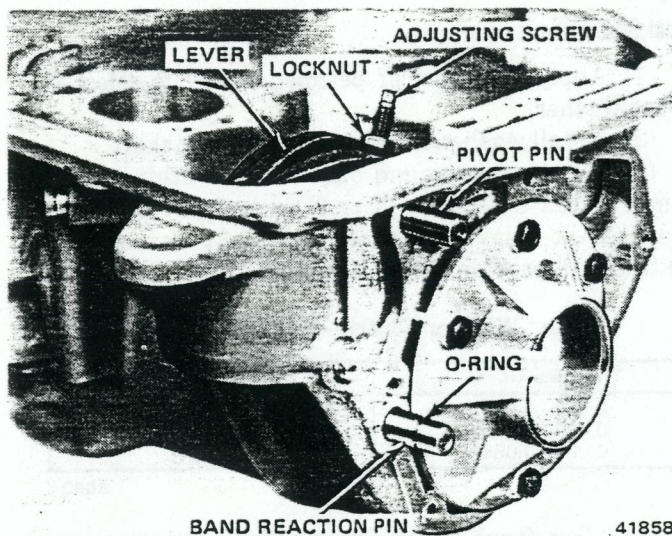

Fig. 2C-99 Rear Band Installation—Model 999

### Front Servo

**NOTE:** On model 727 transmission(s), the servo piston must be subassembled before installation.

- (1) Lubricate O-ring with petroleum jelly and install on piston rod.
- (2) Install rod in piston.
- (3) Install spring, flat washer and snap ring.
- (4) Insert servo piston assembly into case bore.
- (5) Install piston rod, spring(s) and guide.
- (6) Compress piston spring(s) with large C-clamp and install snap ring.
- (7) Remove C-clamp.

### Planetary Gear Assembly and Output Shaft

**CAUTION:** Protect all machined surfaces of the output shaft during installation.

- (1) Position and support gear and output shaft assembly in case and insert output shaft through rear support.
- (2) Carefully work gear and shaft assembly rearward and engage rear planetary carrier lugs in low reverse drum slots.

### Front and Rear Clutch Assemblies

The front and rear clutches, front band, oil pump and reaction shaft support are installed with the transmission in an upright position.

Cut a 3-1/2 inch (9 cm) diameter hole in a workbench, in the end of a small oil drum or a large wooden box strong enough to support the transmission. Cut or file notches at the edge of the hole to accommodate the output shaft.

Carefully insert the output shaft into the hole and support the transmission in an upright position on the output shaft support flange.

**Model 904/999**

- (1) Apply thin coat of petroleum jelly to selective thrust washer.
- (2) Install washer on front end of output shaft.
- (3) If transmission end play was not within specifications (0.022 to 0.091 inch or 0.056 to 2.31 mm) when measured at disassembly, replace thrust washer with one that will provide proper end play.

**Thrust Washer Chart—Model 904/999**

| Thickness (Inch) | Color           |
|------------------|-----------------|
| 0.052 - 0.054    | Natural (Brown) |
| 0.068 - 0.070    | Red             |
| 0.083 - 0.085    | Black           |

60234

- (4) Align front clutch inner splines and place assembly in position on rear clutch.

**NOTE:** Be sure the front clutch plate splines are fully engaged on the rear clutch front hub.

- (5) Align rear clutch inner splines.
- (6) Install clutch assemblies. Grasp input shaft and lower assemblies into case to install them.
- (7) Install clutch assemblies using twisting motion and engage rear clutch splines over splines of front annulus gear.

**NOTE:** Be sure the front clutch drive lugs are fully engaged in the driving shell slots.

**Model 727**

- (1) Apply thin coat of petroleum jelly to output shaft thrust washer.
- (2) Install washer on front of output shaft.
- (3) Align front clutch inner splines and place assembly in position on rear clutch.

**NOTE:** Be sure the front clutch splines are fully engaged on the rear clutch front hub.

- (4) Align rear clutch inner splines.
- (5) Install clutch assemblies. Grasp input shaft and lower clutch assemblies into case to install them.
- (6) Install clutch assemblies using a twisting motion to engage rear clutch splines over splines of front annulus gear.

**NOTE:** Be sure the front clutch drive lugs are fully engaged in the driving shell slots.

**Front Band**

- (1) Slide band over front clutch assembly.
- (2) Install band strut. Also install band anchor on model 727 (fig. 2C-100).
- (3) Tighten band adjusting screw enough to hold band and linkage in place.

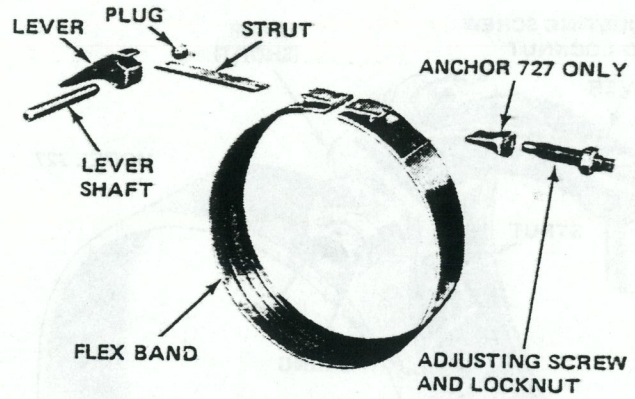

**Fig. 2C-100 Front Band Arrangement**

41859

**Oil Pump and Reaction Shaft Support**

If difficulty was encountered in removing the pump assembly due to an exceptionally tight fit in the case, it may be necessary to heat and expand the case in order to install the pump. If necessary, heat the pump area for a few minutes, using a heat lamp, before installing the pump and support assembly.

**Model 904/999**

- (1) Install thrust washer on reaction shaft support hub.
- (2) Thread two Pilot Studs J-3387-2 into case pump opening.
- (3) Install gasket over studs.
- (4) Install rubber seal ring in groove in outer flange of pump housing. Be sure seal is not twisted.
- (5) Coat seal ring with petroleum jelly.
- (6) Install pump assembly in case. If necessary, tap pump assembly lightly with rawhide mallet to install.
- (7) Install four pump attaching bolts finger-tight.
- (8) Remove pilot studs and install remaining pump attaching bolts finger-tight.
- (9) Rotate input and output shafts to see if any binding exists.
- (10) If shafts rotate freely, tighten all pump attaching bolts to 175 inch-pounds (20 N•m) torque.
- (11) Recheck shafts for bind-free rotation. If bind exists, loosen bolts and tighten bolts alternately and evenly to 175 inch-pounds (20 N•m) torque.

**Model 727**

- (1) If transmission end play was not within specifications (0.036 to 0.084 inch or 0.91 to 2.13 mm) when measured at disassembly, replace thrust washer on reaction shaft support hub with one that will provide correct end play.
- (2) Thread two Pilot Studs Tool J-3387-2 into case pump opening.
- (3) Install gasket over studs.

## Thrust Washer Chart—Model 727

| Thickness (Inch) | Color           |
|------------------|-----------------|
| 0.061 - 0.063    | Natural (Brown) |
| 0.084 - 0.086    | Red             |
| 0.102 - 0.104    | Yellow          |

60235

- (4) Install rubber seal ring in groove in outer flange of pump housing. Be sure seal is not twisted.
- (5) Coat seal ring with petroleum jelly.
- (6) Install pump assembly in case. If necessary, tap pump assembly lightly with rawhide mallet to install.
- (7) Position deflector, if equipped, over vent opening and install four pump attaching bolts finger-tight.
- (8) Remove pilot studs and install remaining pump attaching bolts finger-tight.
- (9) Rotate input and output shafts to see if any binding exists.
- (10) If shafts rotate freely, tighten all pump attaching bolts to 175 inch-pounds (20 N•m) torque.
- (11) Recheck shafts for free rotation. If bind exists, loosen bolts and tighten bolts alternately and evenly to 175 inch-pounds (20 N•m) torque.

## Governor and Park Gear

- (1) Install gear and governor body assembly on output shaft.
- (2) Align assembly so governor valve shaft hole in governor body is aligned with hole in output shaft.
- (3) Slide assembly into place and install snap ring behind governor body.
- (4) Tighten governor body-to-gear attaching bolts to 100 inch-pounds (11 N•m) torque.
- (5) Bend end of lock tabs against shoulders of bolt heads.
- (6) Install governor valve on valve shaft.
- (7) Insert assembly into body and through governor weights.
- (8) Install valve shaft retaining E-clip.

## Output Shaft Bearing and Adapter Housing

- (1) Install bearing in adapter housing if not installed previously.
- (2) Install seal in housing.
- (3) Install bearing snap rings.

## Valve Body and Accumulator Piston

- (1) Before installing valve body, check operation of clutches and bands using air pressure test procedure to confirm proper operation.
- (2) Clean all mating surfaces and remove any burrs from transmission case or valve body steel plate mating surfaces.
- (3) Install accumulator piston assembly in case bore and install piston spring on piston (fig. 2C-101).

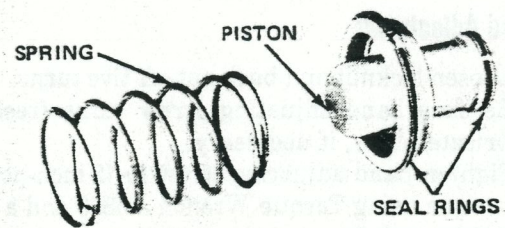

90541

Fig. 2C-101 Accumulator Assembly

- (4) Insert park lock rod through opening in rear of case.
- (5) Position knob of lock rod against reaction plug and sprag.
- (6) Move front end of rod toward centerline of transmission while exerting rearward pressure on rod to force it past sprag. Rotate output shaft, if necessary.

**NOTE:** Before installing the valve body, be sure the neutral start switch has not yet been installed.

- (7) Place valve body manual lever in Drive position.
  - (8) Place valve body assembly in its approximate position in case.
  - (9) Align valve body in case and install attaching screws finger-tight.
  - (10) Install neutral start switch.
  - (11) Shift valve body manual lever to Neutral position.
  - (12) Relocate valve body if necessary to align manual lever neutral finger over neutral start switch plunger ball.
  - (13) Tighten valve body attaching screws to 100 inch-pounds (11 N•m) torque.
  - (14) Install gearshift control lever on manual lever shaft and tighten clamp bolt.
  - (15) Check lever shaft for binding in case by moving lever through all detent positions.
- NOTE:** If binding exists, loosen the valve body attaching screws and align the valve body.
- (16) Install flat washer and throttle lever and tighten throttle lever clamp bolt.

## Rear Band Adjustment

- (1) Loosen locknut and back nut off five turns.
- (2) Tighten band adjusting screw to 72 inch-pounds (8 N•m) torque.

**CAUTION:** If Adapter Tool J-24063 is used to adjust the band, tighten the adjusting screw to 36 inch-pounds (4 N•m) torque only.

- (3) Back off adjusting screw seven turns on 904, four turns on 999, and two turns on 727.
- (4) Hold adjusting screw in position and tighten locknut to 35 foot-pounds (47 N•m) torque.
- (5) Install oil pan and gasket.

**Front Band Adjustment**

- (1) Loosen locknut and back nut off five turns.
- (2) Be sure band adjusting screw turns freely in case. Lubricate screw, if necessary.
- (3) Tighten band adjusting screw to 72 inch-pounds (8 N•m) torque using Torque Wrench J-5853 and a 5/16 (8 mm) square socket.

**CAUTION:** If Adapter Tool J-24063 is used to adjust the band, tighten the adjusting screw to 36 inch-pounds (4 N•m) torque only.

- (4) Back off adjusting screw two turns on 999 and two and one-half turns on 727 and 904.
- (5) Hold adjusting screw in position and tighten locknut to 35 foot-pounds (47 N•m) torque.

**SPECIFICATIONS**

**Transmission Specifications**

|   | MODEL 904                       | MODEL 999  | MODEL 727  |
|---|---------------------------------|--|--|
| <b>Clutch Plate Clearance</b>               |                                 |  |  |
| Front Clutch                                | 3 Disc 0.0074 to 0.125 inch     | 3 Disc 0.074 to 0.125 inch<br>4 Disc 0.067 to 0.134 inch<br>5 Disc 0.075 to 0.152 inch | 3 Disc 0.070 to 0.129 inch<br>4 Disc 0.082 to 0.051 inch |
| Rear Clutch                                 | 3 and 4 Disc 0.032 to 0.55 inch | 3 and 4 Disc 0.032 to 0.55 inch  | 4 Disc 0.025 to 0.045 inch                               |
| <b>Clutch Component Thickness Tolerance</b> |                                 |  |  |
| Front Clutch                                |                                 |  |  |
| Lined Plate                                 | 0.083 to 0.088 inch             | 0.083 to 0.088 inch  | 0.090 to 0.095 inch                                      |
| Steel Plate                                 | 0.066 to 0.071 inch             | 0.066 to 0.071 inch  | 0.066 to 0.071 inch                                      |
| Pressure Plate                              | 0.244 to 0.218 inch             | 0.244 to 0.218 inch  | 0.278 to 0.282 inch                                      |
| Rear Clutch                                 |                                 |  |  |
| Lined Plate                                 | 0.060 to 0.065 inch             | 0.060 to 0.065 inch  | 0.060 to 0.065 inch                                      |
| Steel Plate                                 | 0.066 to 0.071 inch             | 0.066 to 0.071 inch  | 0.066 to 0.071 inch                                      |
| Flat Pressure Plate                         | 0.214 to 0.218 inch             | 0.214 to 0.218 inch  | 0.278 to 0.282 inch                                      |
| Formed Pressure Plate                       | 0.409 to 0.413 inch             | 0.409 to 0.413 inch  | 0.441 to 0.445 inch                                      |
| <b>Clutches</b>                             |                                 |  |  |
| Number of Front Clutch Plates               | 3                               | 5  | 4  |
| Number of Front Clutch Discs                | 3                               | 5  | 4  |
| Number of Rear Clutch Plates                | 3                               | 3  | 3  |
| Number of Rear Clutch Discs                 | 4                               | 4  | 4  |

70122A

**Transmission Specifications (Continued)**

|   | MODEL 904   |   | MODEL 999   |                     | MODEL 727   |                      |
|---|---|---|---|---------------------|---|----------------------|
|   | U.S. Measure  | Metric Measure                              | U.S. Measure  | Metric Measure      | U.S. Measure  | Metric Measure       |
| <b>Torque Converter Diameter</b>                        | 9.50 inches   |   | 10.75 inches  |                     |   |                      |
| <b>Oil Capacity - Transmission and Torque Converter</b> | 14.2 pts.   | 6.6 liters                                  | 17. pts.  | 7.9 liters          | 17 pts.   | 7.9 liters           |
| <b>Cooling Method - All Models</b>                      | Water-Heat Exchanger (In Radiator Lower Tank)               |   |   |                     |   |                      |
| <b>Lubrication - All Models</b>                         | Rotor Type Pump   |   |   |                     |   |                      |
| <b>Gear Ratios - All Models</b>                         | First<br>2.74 to 1<br>Third<br>1.00 to 1                    | Second<br>1.55 to 1<br>Reverse<br>2.20 to 1 | First<br>2.45 to 1  | Second<br>1.45 to 1 | Third<br>1.00 to 1  | Reverse<br>2.20 to 1 |
| <b>Pump Clearances</b>                                  |   |   |   |                     |   |                      |
| Outer Rotor to Case Bore                                |   |   | .004 to .008 inch   |                     |   |                      |
| Outer to Inner Tip                                      |   |   | .005 to .010 inch   |                     |   |                      |
| End Clearance-Rotors                                    | .001 to .003 inch   |   | .001 to .003 inch   |                     | .001 to .002 inch   |                      |
| <b>Gear Train End Play</b>                              | .001 to .047 inch   |   | .001 to .047 inch   |                     | .009 to .044 inch   |                      |
| <b>Input Shaft End Play</b>                             | .022 to .091 inch   |   | .016 to .059 inch   |                     | .036 to .084 inch   |                      |
| <b>Snap Rings</b>                                       |   |   |   |                     |   |                      |
| Front and Rear Clutches Rear Snap Ring (Selective)      | .060 to .062 inch<br>.068 to .070 inch<br>.076 to .078 inch |   | .060 to .062 inch<br>.068 to .070 inch<br>.076 to .078 inch |                     | .060 to .062 inch<br>.074 to .076 inch<br>.088 to .090 inch |                      |
| Output Shaft (Forward End)                              | .040 to .044 inch<br>.048 to .052 inch<br>.059 to .065 inch |   | .040 to .044 inch<br>.048 to .052 inch<br>.059 to .065 inch |                     | .106 to .108 inch<br>.055 to .059 inch<br>.062 to .066 inch |                      |

70122B

Thrust Washer Chart

| Thrust Washers                                  | Thrust Washer No. and Transmission Model |   |       |  |
|---|--|---|-------|--|
|   | 904/999                                  |   | 727   |  |
| Reaction Shaft Support to Front Clutch Retainer | No. 1                                    | .061 to .063  | No. 1 | Selective<br>.061 to .063 – Natural<br>.084 to .086 – Red<br>.102 to .104 – Yellow |
| Rear Clutch to Front Clutch Retainer            | No. 2                                    | .061 to .063  | No. 2 | .061 to .063 – Natural   |
| Output Shaft to Input Shaft                     | No. 3                                    | Selective<br>.052 to .054 – Tin<br>.068 to .070 – Red<br>.083 to .085 – Green | No. 3 | .062 to .064   |
| Front Annulus Support to Rear Clutch Retainer   | No. 4                                    | .121 to .125  |       | —  |
| Front Annulus Support to Front Planetary Gear   | No. 5                                    | .048 to .050  | No. 4 | .059 to .062   |
| Driving Shell to Front Annulus Gear             |  | —   | No. 5 | .060 to .062   |
| Front Planetary Gear to Driving Shell           | No. 6                                    | .048 to .050  |       | —  |
| Sun Gear and Driving Shell Front Thrust Plate   | No. 7                                    | .050 to .052  | No. 6 | .034 to .036   |
| Sun Gear and Driving Shell Rear Thrust Plate    | No. 8                                    | .050 to .052  |       | —  |
| Rear Planetary Gear to Driving Shell            | No. 9                                    | .048 to .050  | No. 7 | .059 to .062   |
| Rear Planetary Gear to Rear Annulus Gear        |  | —   | No. 8 | .034 to .036   |
| Rear Planetary Gear to Rear Annulus Support     | No. 10                                   | .048 to .050  |       | —  |

60517

Torque Specifications

Service Set-To Torques should be used when assembling components. Service In-Use Recheck Torques should be used for checking a pre-torqued item.

|  | USA (in-lbs)          |                               | Metric (N·m)          |                               |
|--|-----------------------|-------------------------------|-----------------------|-------------------------------|
|  | Service Set-To Torque | Service In-Use Recheck Torque | Service Set-To Torque | Service In-Use Recheck Torque |
| Cooler Line Fitting  | 160 in-lb             | 120-200 in-lb                 | 18                    | 14-23                         |
| Cooler Line Nut  | 150 in-lb             | 130-180 in-lb                 | 17                    | 15-20                         |
| Converter Drive Plate to Crankshaft Bolts - 4 Cylinder       | 58                    | 50-56                         | 79                    | 68-89                         |
| Converter Drive Plate to Crankshaft Bolts - 6 Cylinder       | 105                   | 95-120                        | 142                   | 129-163                       |
| Converter Drive Plate to Torque Converter Bolts - 4 Cylinder | 40                    | 35-40                         | 54                    | 47-54                         |
| Converter Drive Plate to Torque Converter Bolts - 6 Cylinder | 26                    | 22-30                         | 35                    | 30-44                         |
| Adapter Housing-to-Transmission Case Bolt                    | 24                    | —                             | 33                    | —                             |
| Governor Body Bolt   | 100 in-lb             | —                             | 11                    | —                             |
| Front Band Adjusting Screw Locknut                           | 35                    | —                             | 47                    | —                             |
| Kickdown Lever Shaft Plug                                    | 150 in-lb             | —                             | 17                    | —                             |
| Rear Band Adjusting Screw Locknut                            | 35                    | —                             | 47                    | —                             |
| Neutral Starter Switch                                       | 24                    | —                             | 33                    | —                             |
| Oil Filler Tube Bracket Bolt                                 | 150 in-lb             | —                             | 17                    | —                             |
| Oil Pan Bolt   | 150 in-lb             | 9-13                          | 17                    | 12-18                         |
| Oil Pump Housing-to-Transmission Case Bolt                   | 175 in-lb             | —                             | 20                    | —                             |
| Output Shaft Support Bolt                                    | 150 in-lb             | —                             | 17                    | —                             |
| Overrunning Clutch Cam Setscrew                              | 40 in-lb              | —                             | 4                     | —                             |
| Pressure Test Port Plug                                      | 110 in-lb             | —                             | 12                    | —                             |
| Reaction Shaft Support to Oil Pump Bolt                      | 160 in-lb             | —                             | 18                    | —                             |
| Transmission-to-Engine Bolt                                  | 28                    | 22-30                         | 38                    | 30-41                         |
| Valve Body Screw   | 35 in-lb              | —                             | 4                     | —                             |
| Valve Body-to-Transmission Case Screw                        | 100 in-lb             | —                             | 11                    | —                             |

All Torque values given in inch-pounds and Newton-meters with dry fits unless otherwise specified.

**Band Adjustments**

|                        | 904   | 999 | 727   |
|------------------------|-------|-----|-------|
| Front Band Turns ..... | 2-1/2 | 2   | 2-1/2 |
| Rear Band Turns .....  | 7     | 4   | 2     |

NOTE: \* 904 backed off from 41 inch-lbs (5 N.m);  
999/727 backed off from 72 inch-lb (8 N.m).

70130

**Tools**

J-24043  
VALVE BODY  
SUPPORT STAND

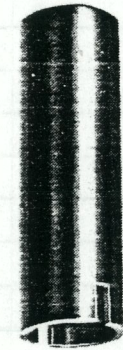
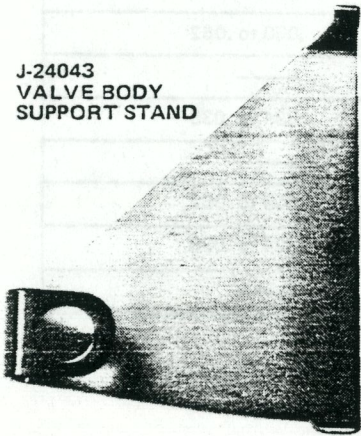

J-24045 (727)



J-24033 (999)

PUMP ROTOR ALIGNMENT TOOLS



J-22205  
FRONT PUMP OIL  
SEAL REMOVER (LEGS)



J-24031  
KICKDOWN  
VALVE GAUGE



J-9617  
FRONT PUMP OIL  
SEAL INSTALLER (999)

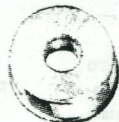

J-24039  
FRONT CLUTCH  
RETAINER BUSHING  
REMOVER AND  
INSTALLER (727)

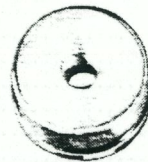

J-24055  
OIL PUMP BUSHING  
REMOVER AND INSTALLER (727)



J-24064  
FRONT CLUTCH BUSHING  
REMOVER AND INSTALLER (999)

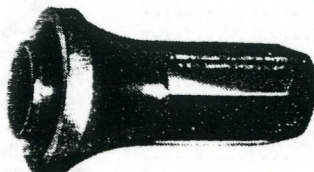

J-21005  
FRONT PUMP OIL  
SEAL INSTALLER (727)

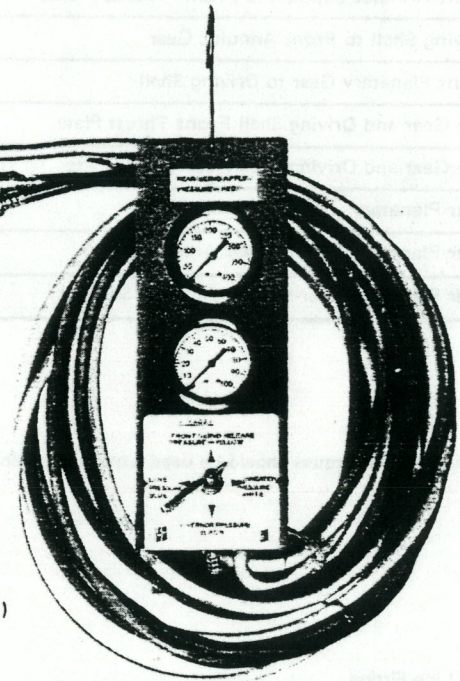

J-24027 PRESSURE TEST SET



J-24044  
DETENT BALL  
RETAINER



J-24040  
INPUT SHAFT  
BUSHING INSTALLER (727)



J-24049  
OIL PUMP BUSHING  
REMOVER AND INSTALLER (999)



J-5886-01  
FRONT CLUTCH  
SPRING COMPRESSOR (999)

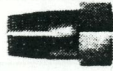

J-24036  
REACTION SHAFT  
BUSHING REMOVER (999)



J-24041  
INPUT SHAFT  
BUSHING REMOVER (727)

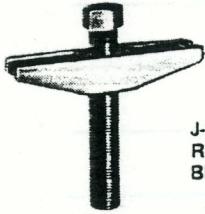

J-21232-01  
FRONT PUMP OIL  
SEAL REMOVER  
(STEERING WHEEL  
PULLER)

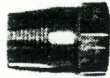

J-24037  
REACTION SHAFT  
BUSHING REMOVER (727)



J-24036  
REACTION SHAFT  
BUSHING REMOVER (999)

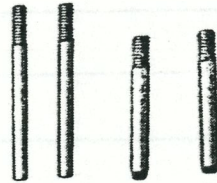

J-24108      J-3387-2

PILOT STUDS



J-24042  
FRONT CLUTCH SPRING  
COMPRESSOR AND  
OVERRUNNING CLUTCH  
CAM INSTALLER (727)



J-24063  
KICKDOWN BAND  
ADJUSTMENT ADAPTOR



J-24026  
TRANSMISSION  
HOLDING FIXTURE



J-24048  
EXTENSION HOUSING  
BUSHING REMOVER  
AND INSTALLER (727)

J-8001  
DIAL INDICATOR  
SET

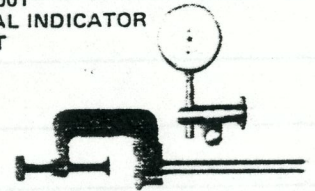





---

# HYDRAULIC FLOW CHARTS

---

---

HYDRAULIC  
FLOW CHARTS

---

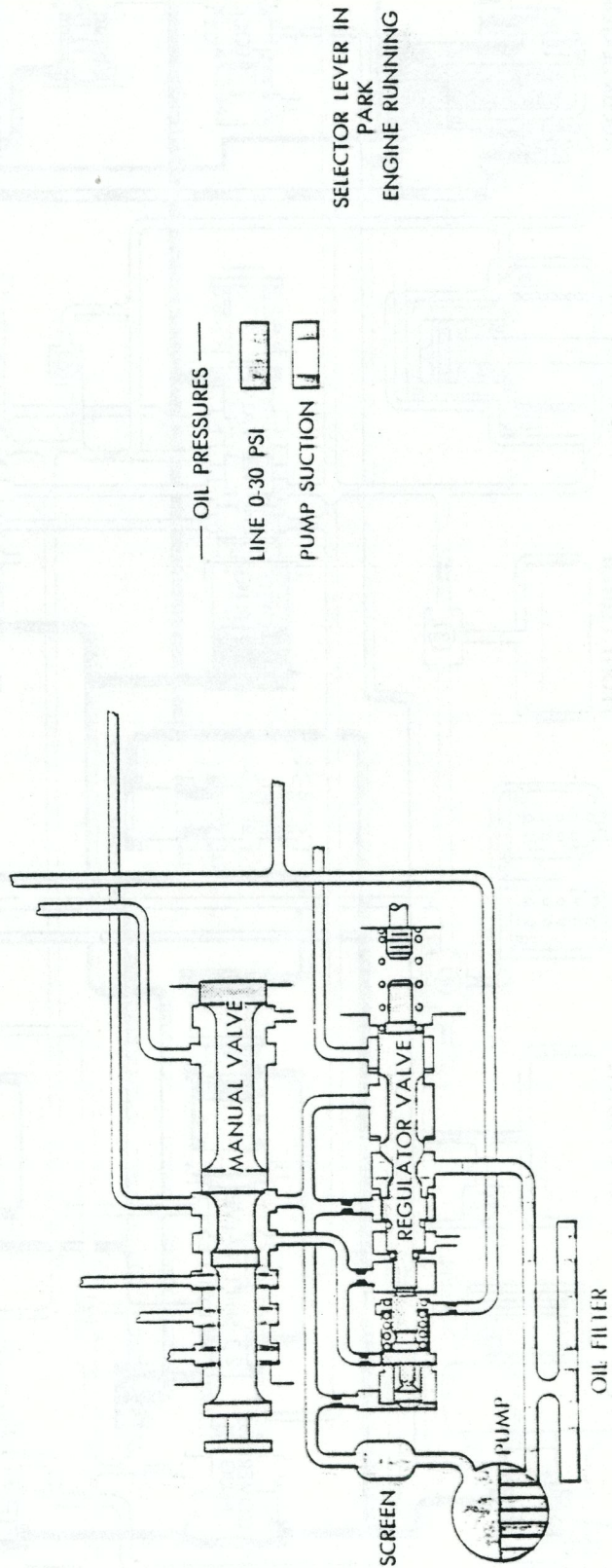
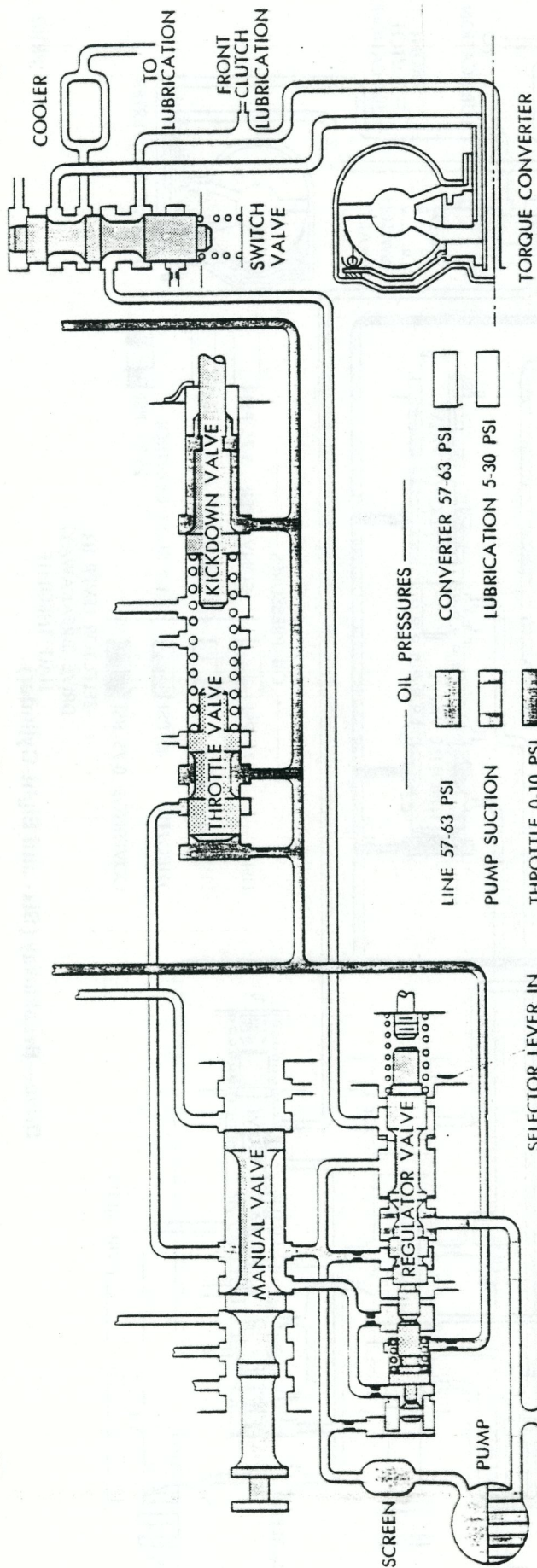

Park and Neutral (All)

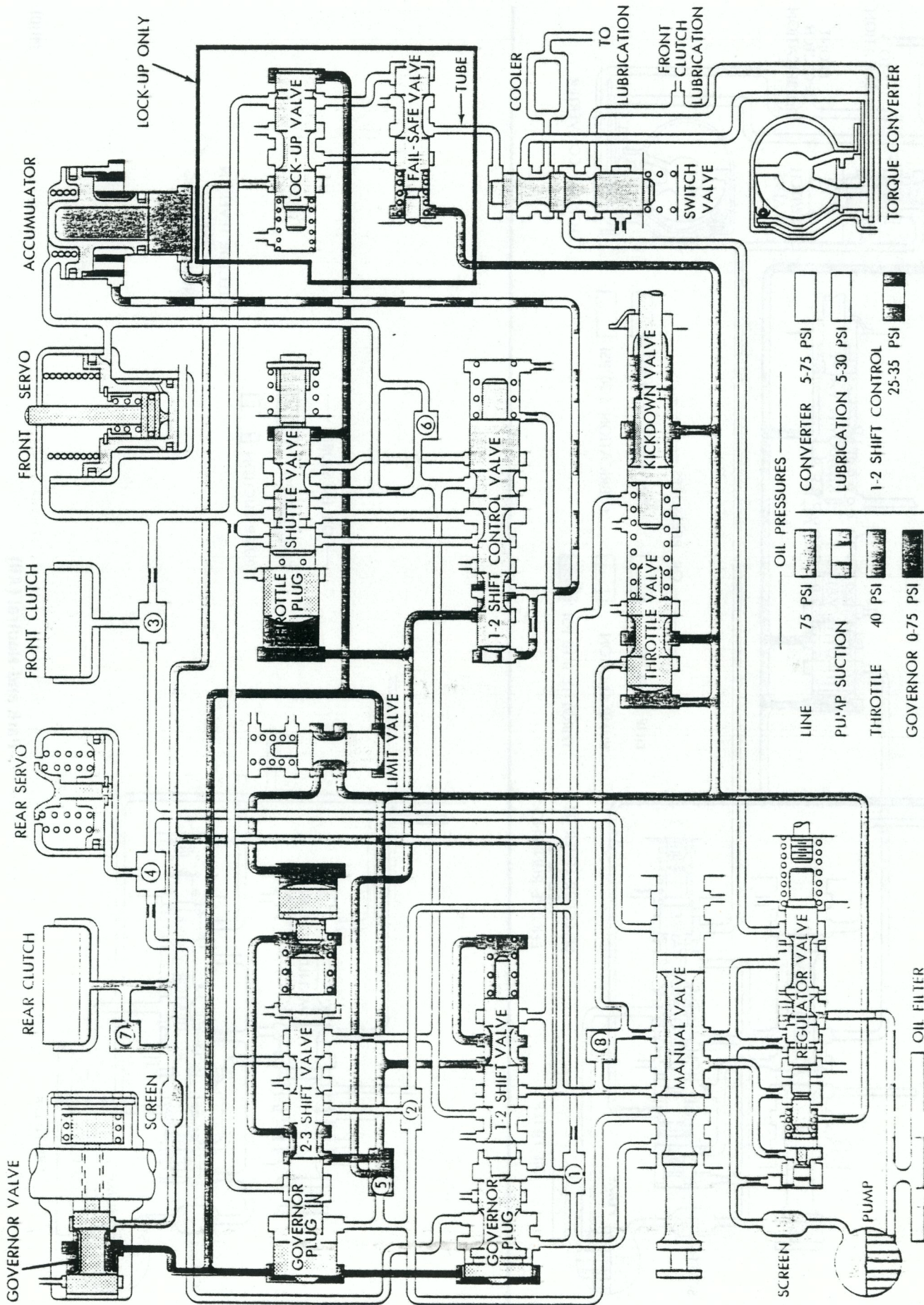

OIL PRESSURES

|              |          |                   |           |
|--------------|----------|-------------------|-----------|
| LINE         | 75 PSI   | CONVERTER         | 5-75 PSI  |
| PUMP SUCTION |          | LUBRICATION       | 5-30 PSI  |
| THROTTLE     | 40 PSI   | 1-2 SHIFT CONTROL | 25-35 PSI |
| GOVERNOR     | 0-75 PSI |                   |           |

SELECTOR LEVER IN  
 DRIVE (BREAKAWAY)  
 HALF THROTTLE

Drive—Breakaway (Six- and Eight-Cylinder)

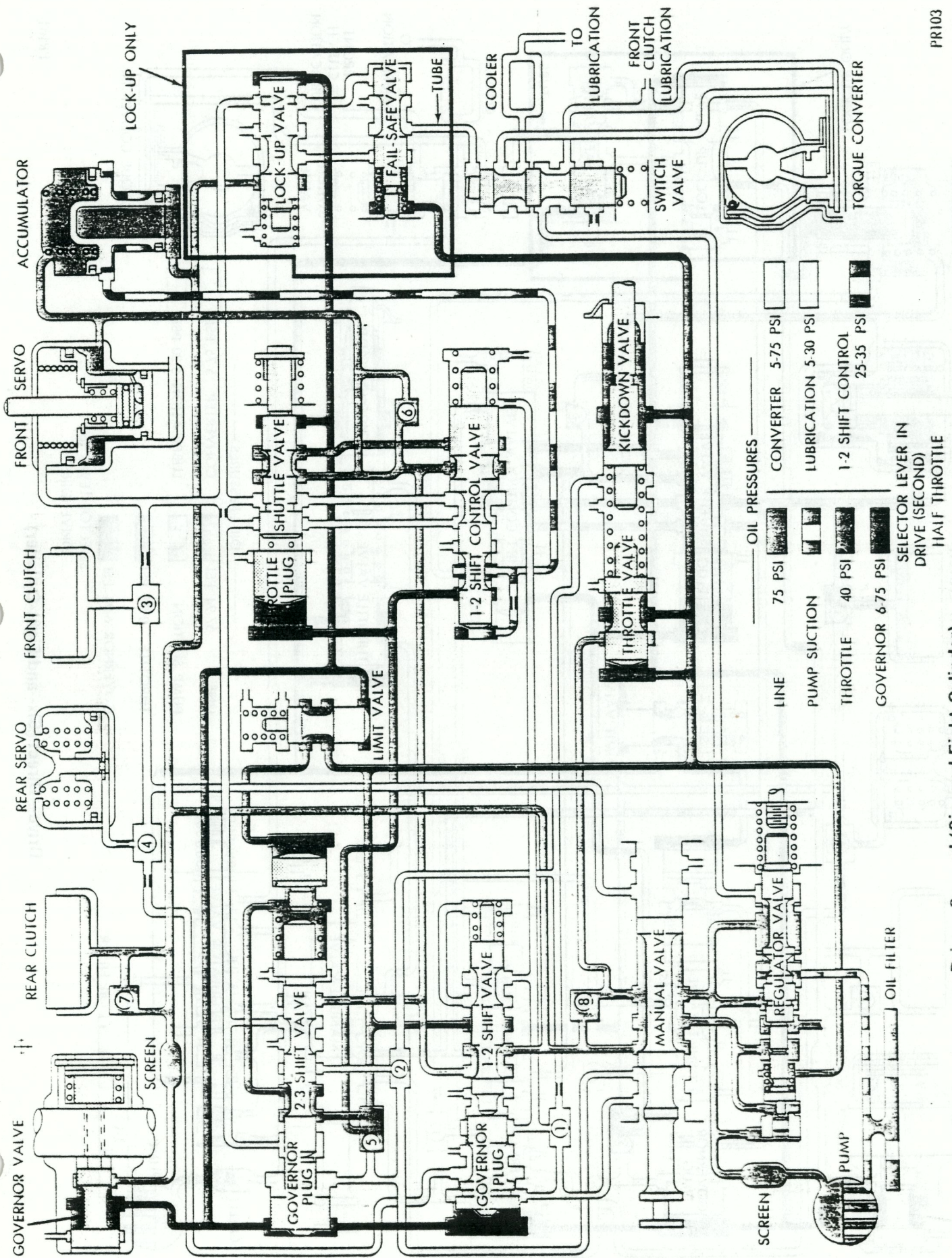

PR103

Drive—Second (Six- and Eight-Cylinder)

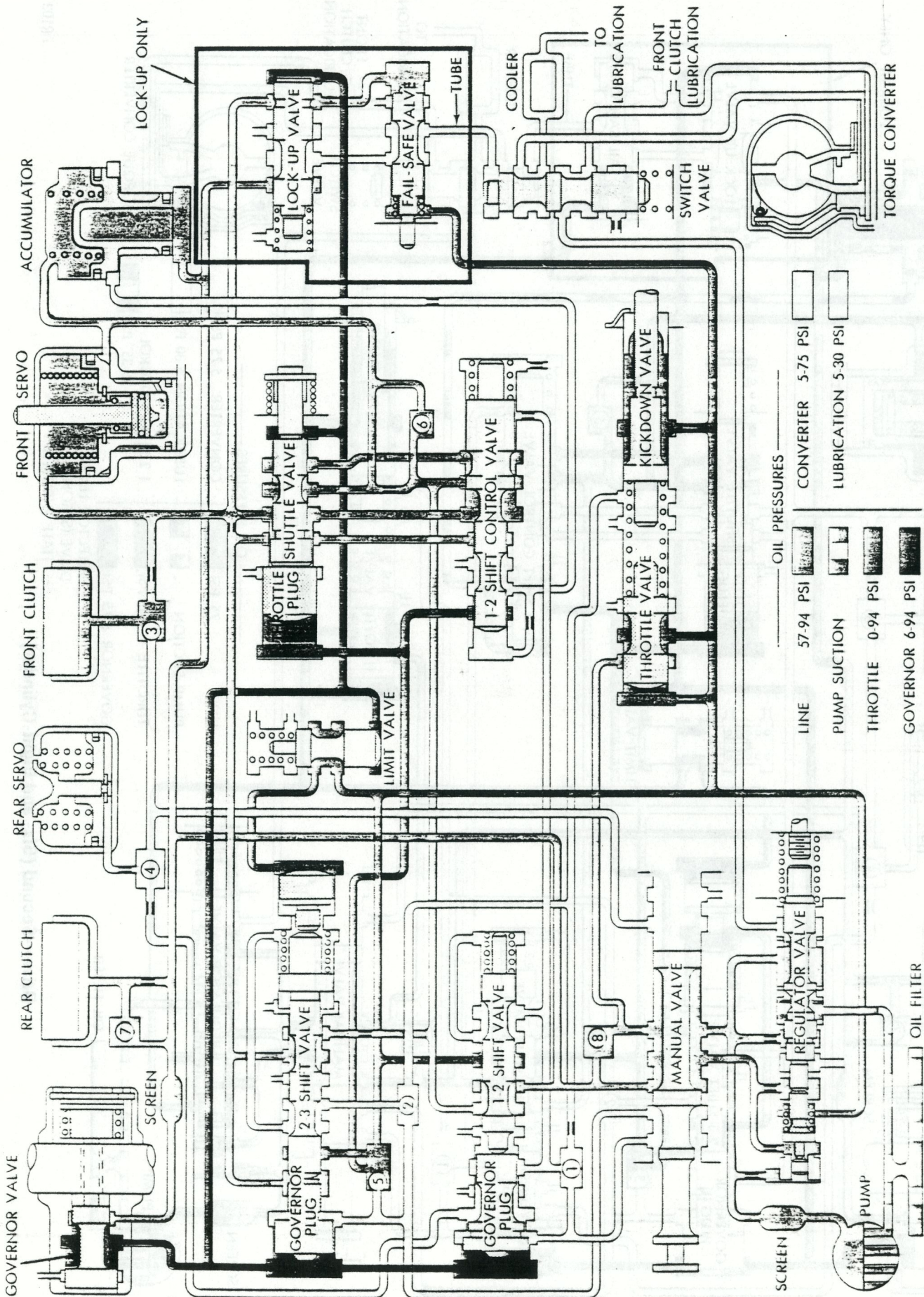

OIL PRESSURES

|              |           |             |          |
|--------------|-----------|-------------|----------|
| LINE         | 57-94 PSI | CONVERTER   | 5-75 PSI |
| PUMP SUCTION |           | LUBRICATION | 5-30 PSI |
| THROTTLE     | 0-94 PSI  |             |          |
| GOVERNOR     | 6-94 PSI  |             |          |

SELECTOR LEVER IN  
DRIVE (DIRECT)

Drive—Direct (Six- and Eight-Cylinder)

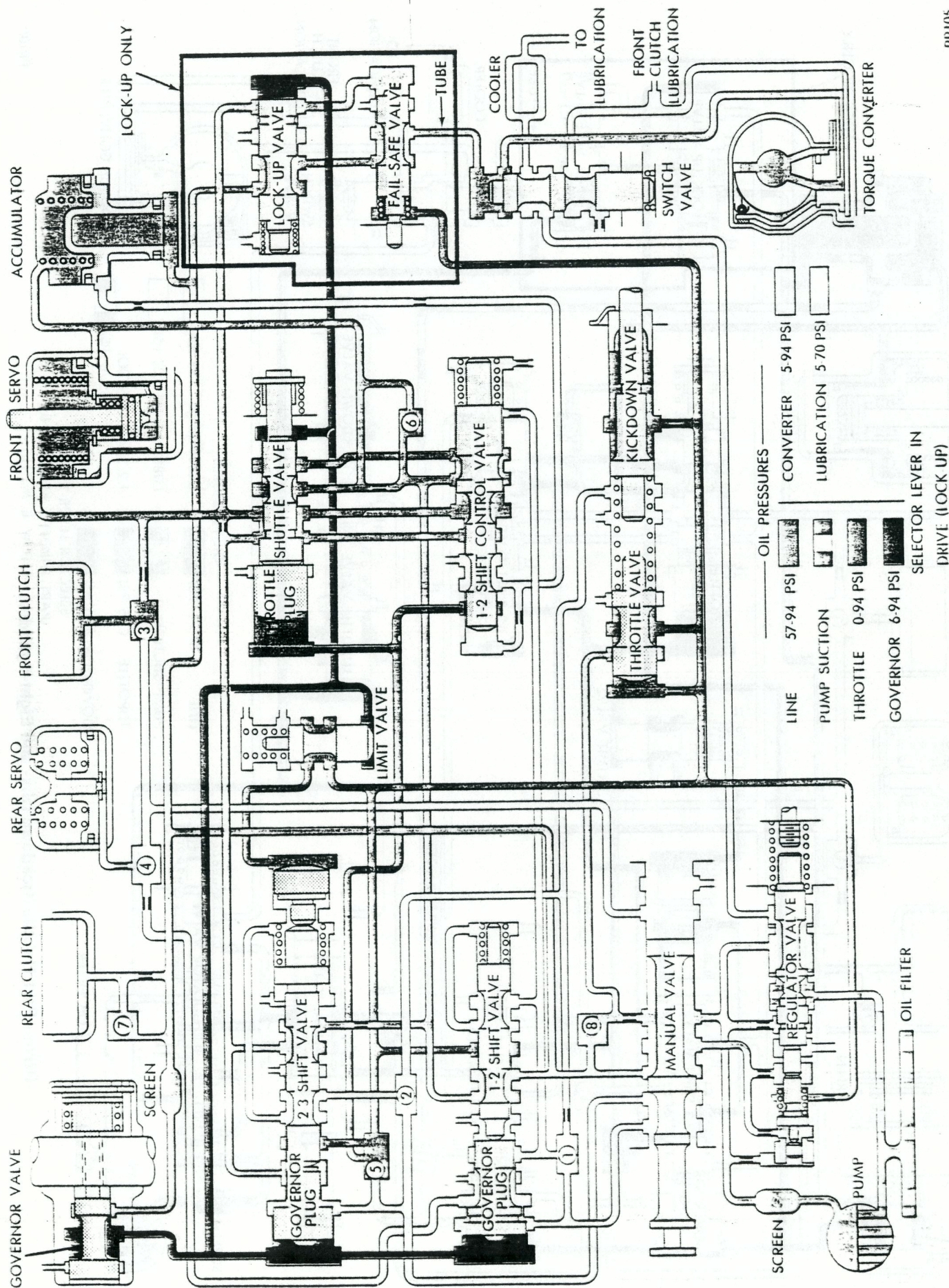

Drive—Direct Lockup (Six- and Eight-Cylinder)

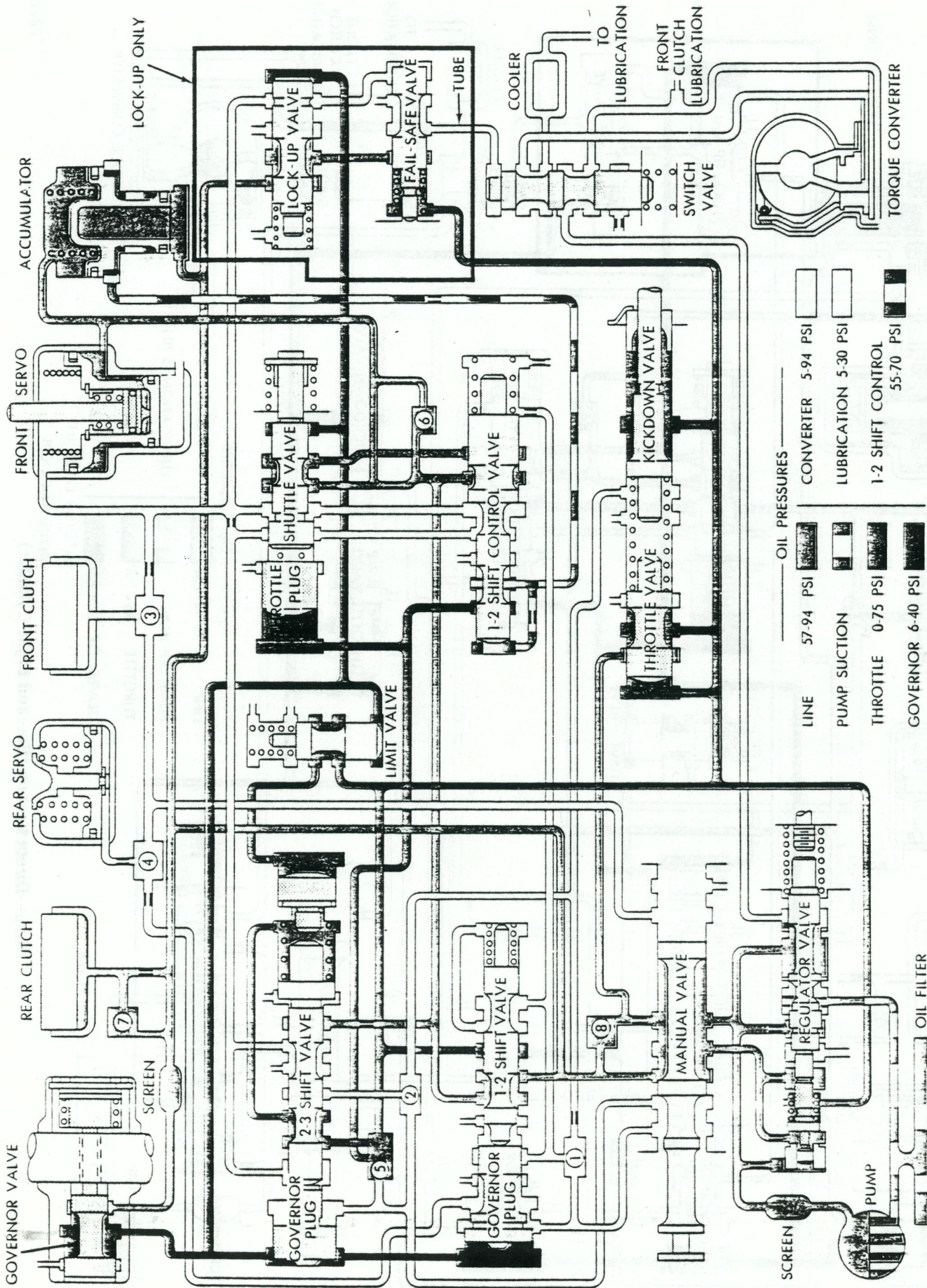

Drive—Part Throttle Kickdown (Six- and Eight-Cylinder)



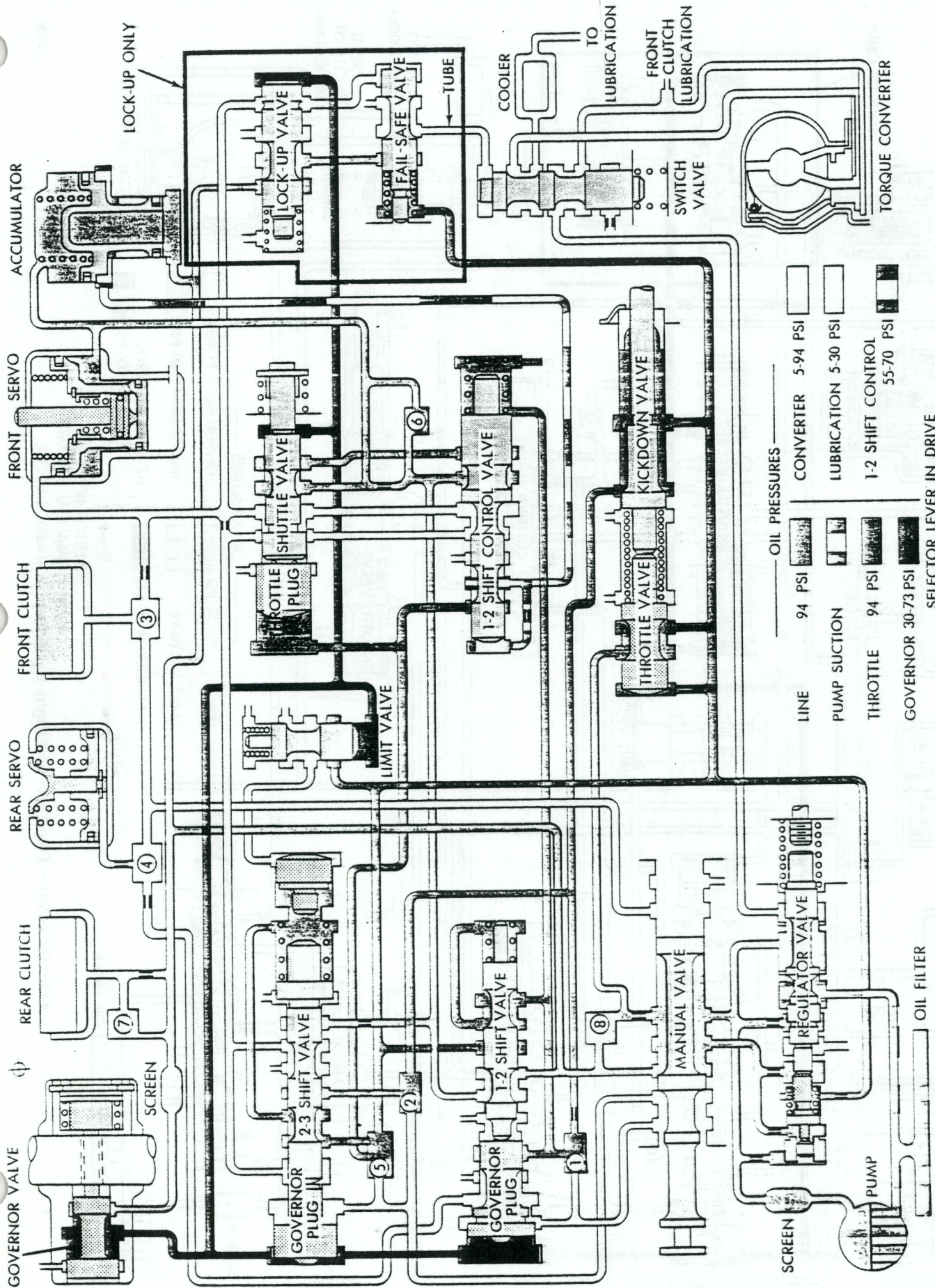

**OIL PRESSURES**

|              |           |                   |           |
|--------------|-----------|-------------------|-----------|
| LINE         | 94 PSI    | CONVERTER         | 5-94 PSI  |
| PUMP SUCTION |           | LUBRICATION       | 5-30 PSI  |
| THROTTLE     | 94 PSI    | 1-2 SHIFT CONTROL | 55-70 PSI |
| GOVERNOR     | 30-73 PSI |                   |           |

SELECTOR LEVER IN DRIVE  
 (FULL THROTTLE KICKDOWN)  
 HALF THROTTLE

Drive—Full Throttle Kickdown (Six- and Eight-Cylinder)

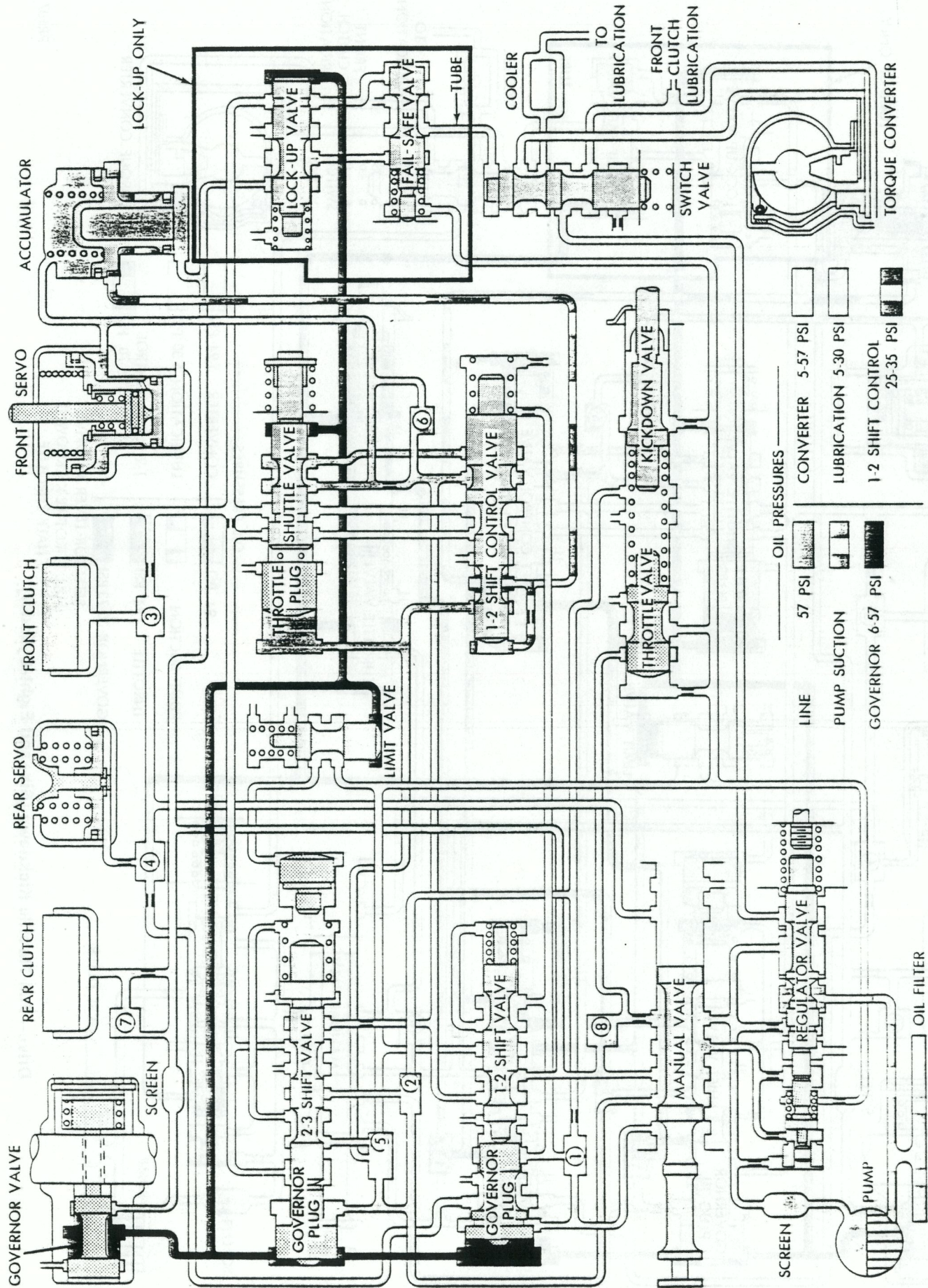

Selector Lever—Two (Six- and Eight-Cylinder) CLOSED THROTTLE  
 Selector Lever IN TWO (MANUAL SECOND)

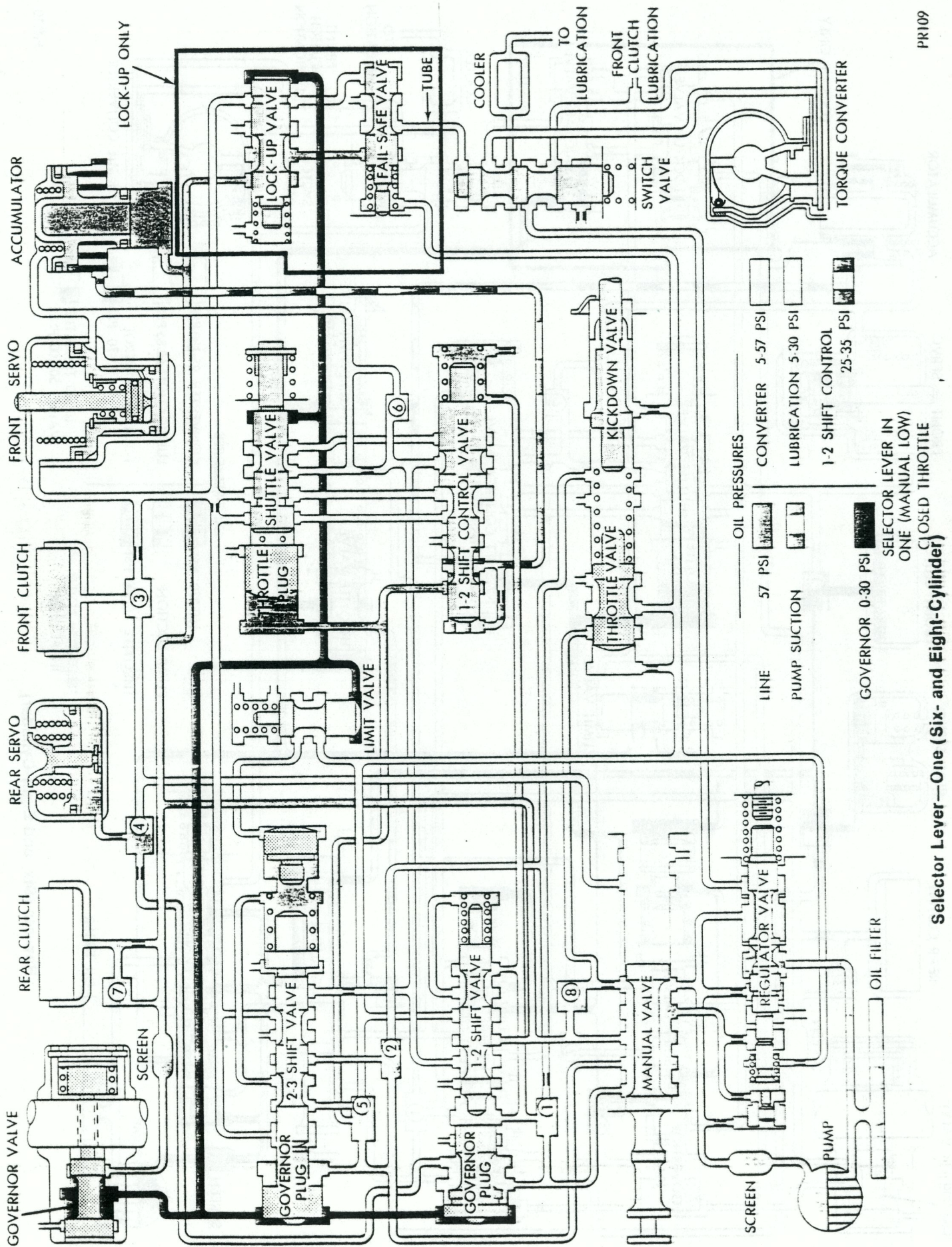

Selector Lever—One (Six- and Eight-Cylinder)

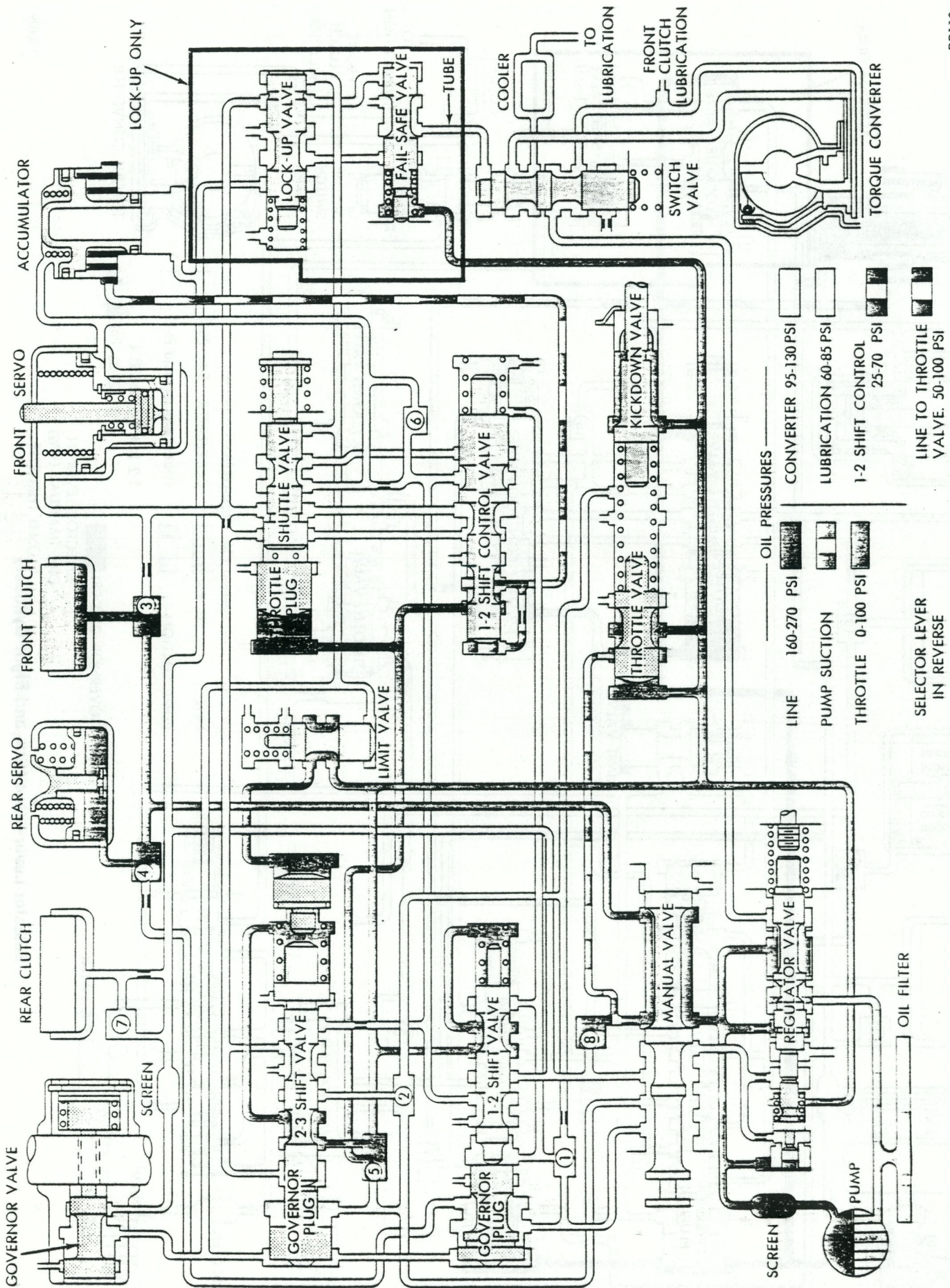

PR110

Reverse (Six- and Eight-Cylinder)

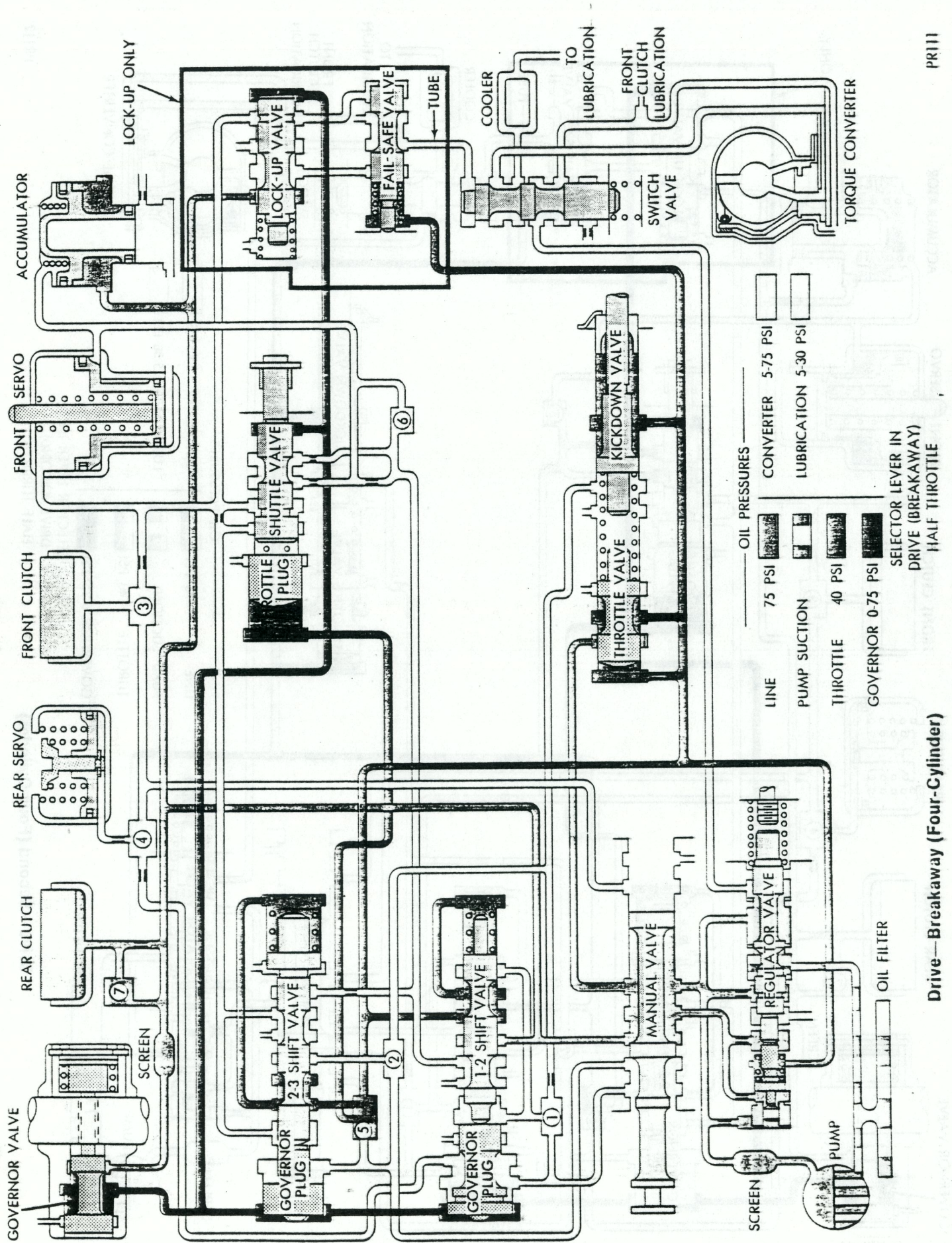

Drive—Breakaway (Four-Cylinder)

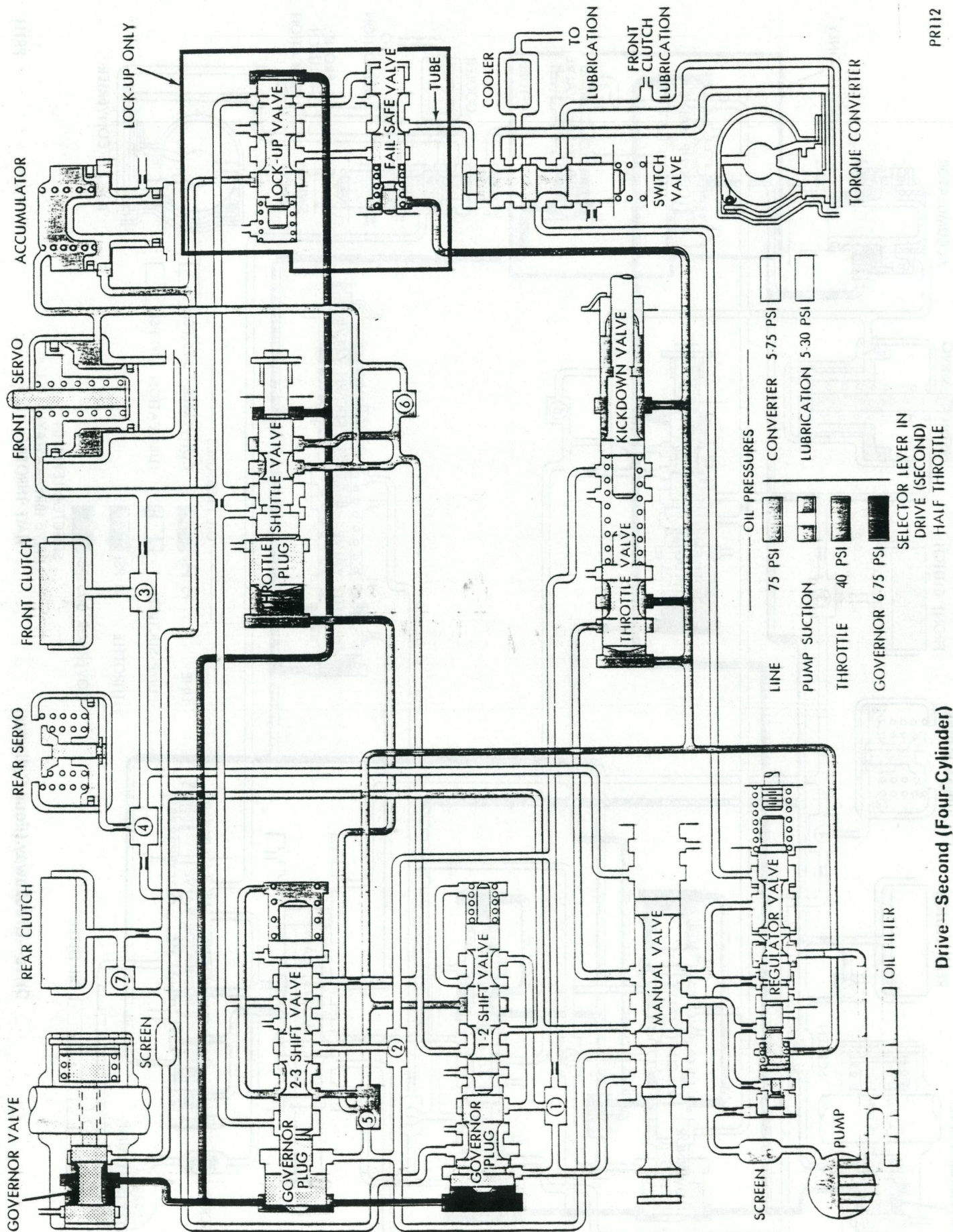

Drive—Second (Four-Cylinder)

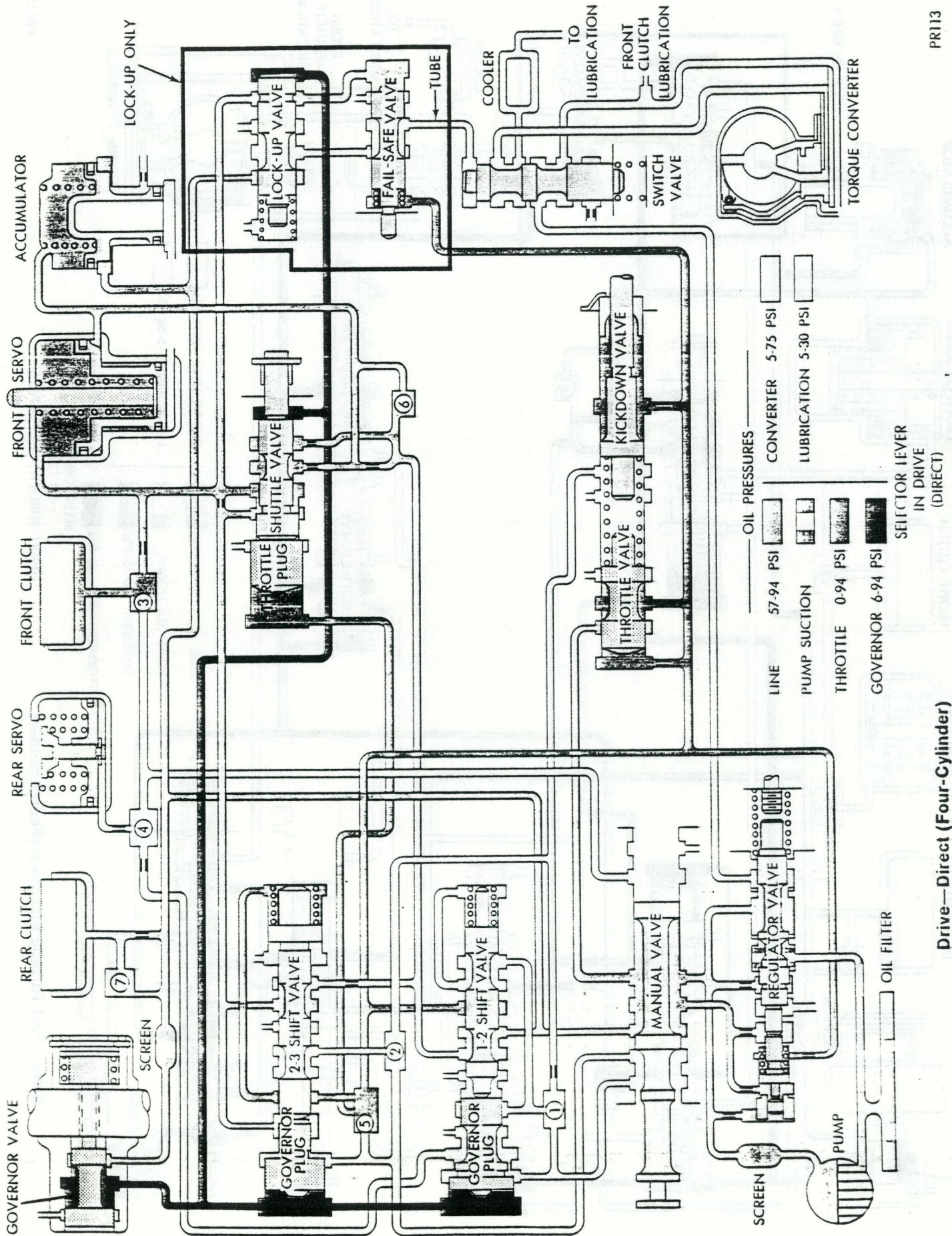

Drive—Direct (Four-Cylinder)

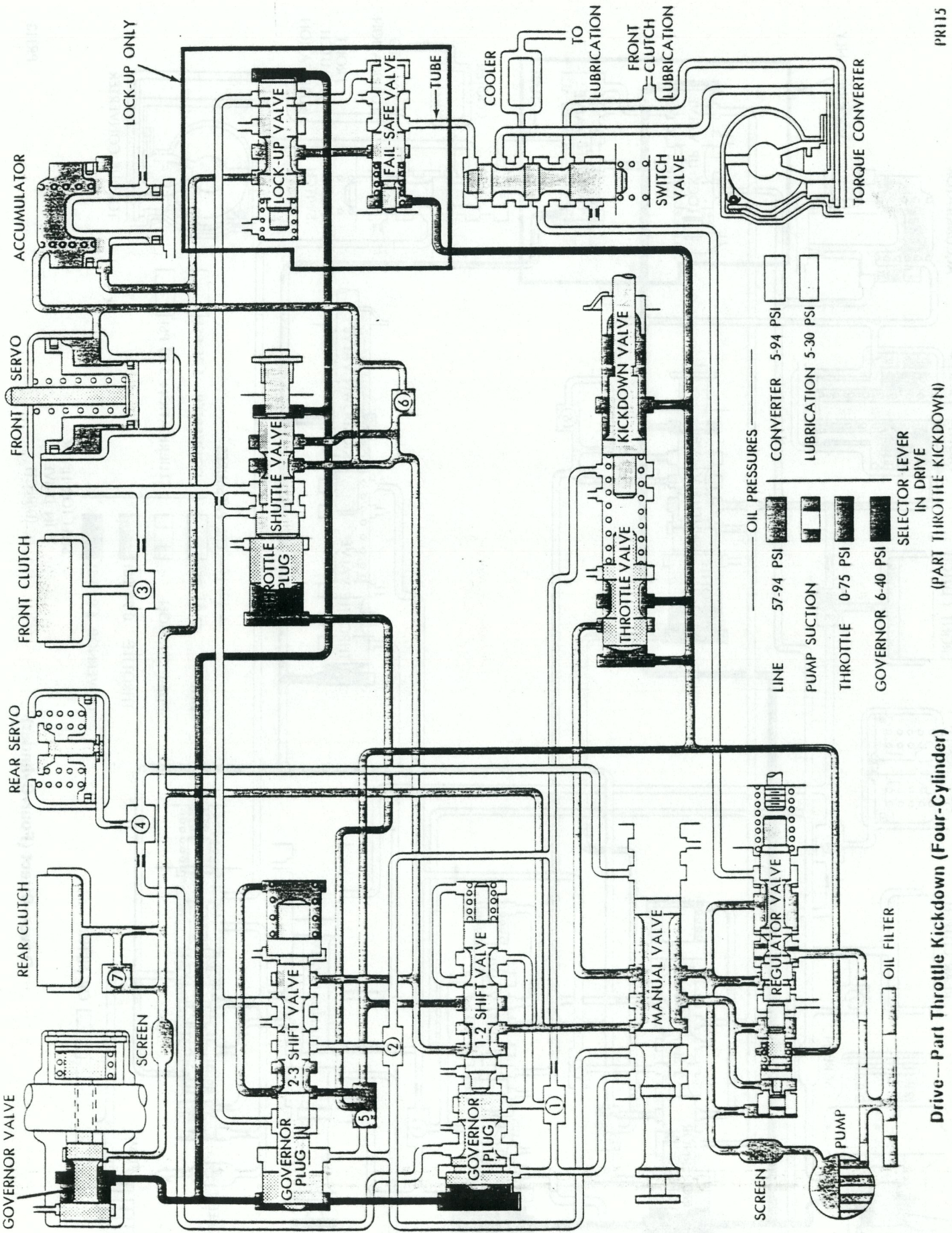

Drive—Part Throttle Kickdown (Four-Cylinder)



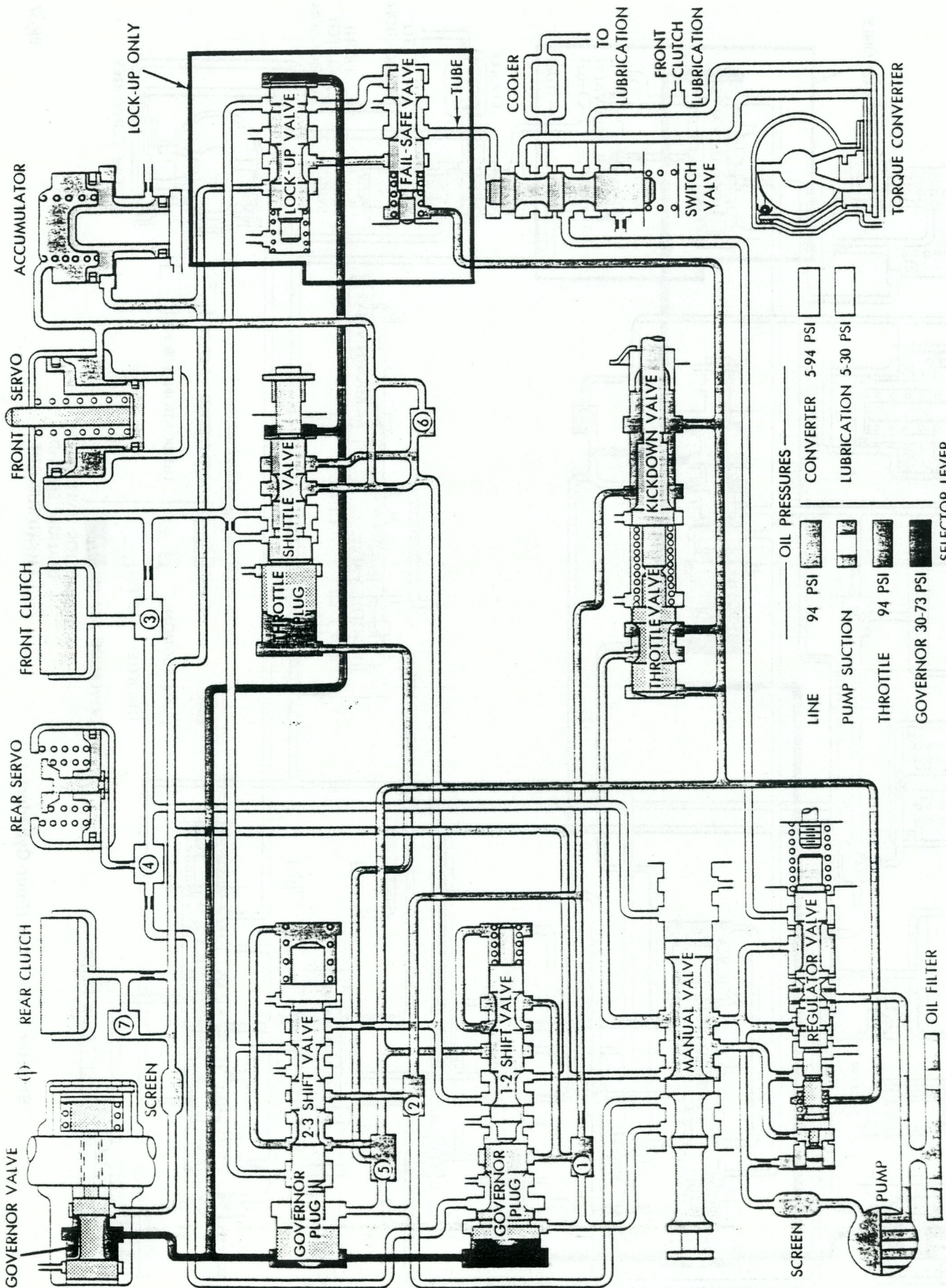

OIL PRESSURES

|              |           |             |          |
|--------------|-----------|-------------|----------|
| LINE         | 94 PSI    | CONVERTER   | 5-94 PSI |
| PUMP SUCTION | 5-7 PSI   | LUBRICATION | 5-30 PSI |
| THROTTLE     | 94 PSI    |             |          |
| GOVERNOR     | 30-73 PSI |             |          |

SELECTOR LEVER IN DRIVE (FULL THROTTLE KICKDOWN)

Drive—Full Throttle Kickdown (Four-Cylinder)

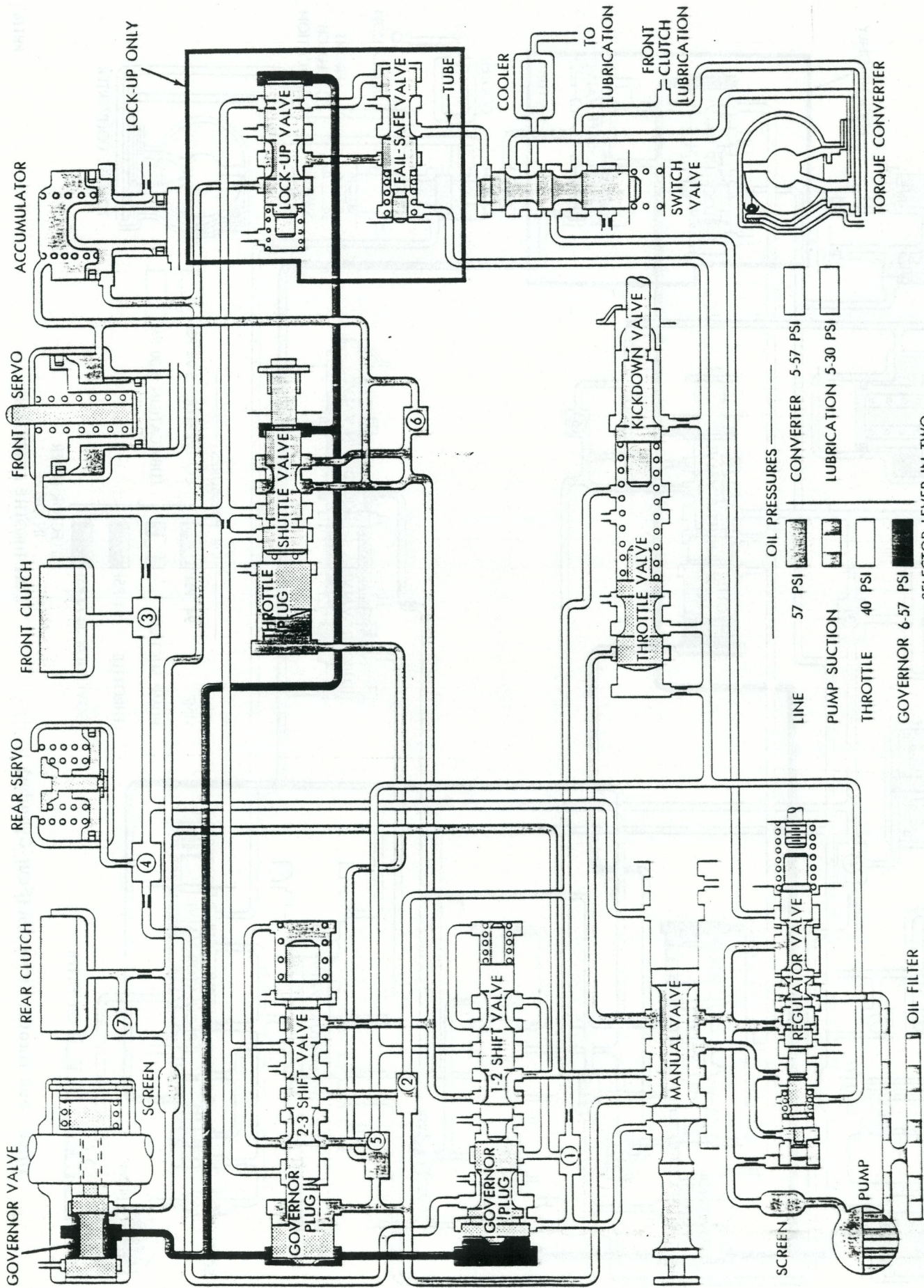

OIL PRESSURES

|              |          |             |          |
|--------------|----------|-------------|----------|
| LINE         | 57 PSI   | CONVERTER   | 5-57 PSI |
| PUMP SUCTION |          | LUBRICATION | 5-30 PSI |
| THROTTLE     | 40 PSI   |             |          |
| GOVERNOR     | 6-57 PSI |             |          |

SELECTOR LEVER IN TWO (MANUAL SECOND) CLOSED THROTTLE

Selector Lever—Two (Four-Cylinder)

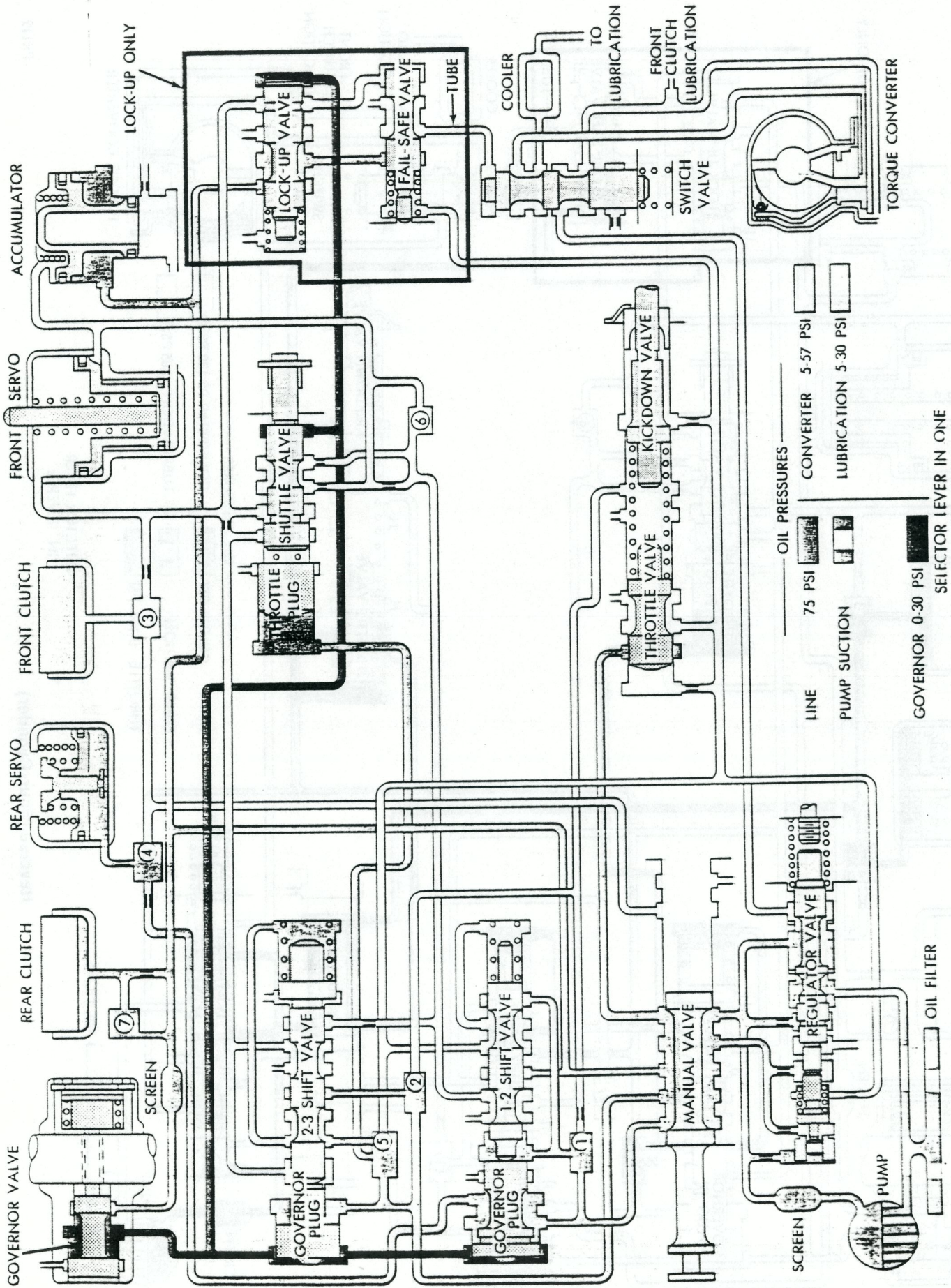

Selector Lever—One (Four-Cylinder)

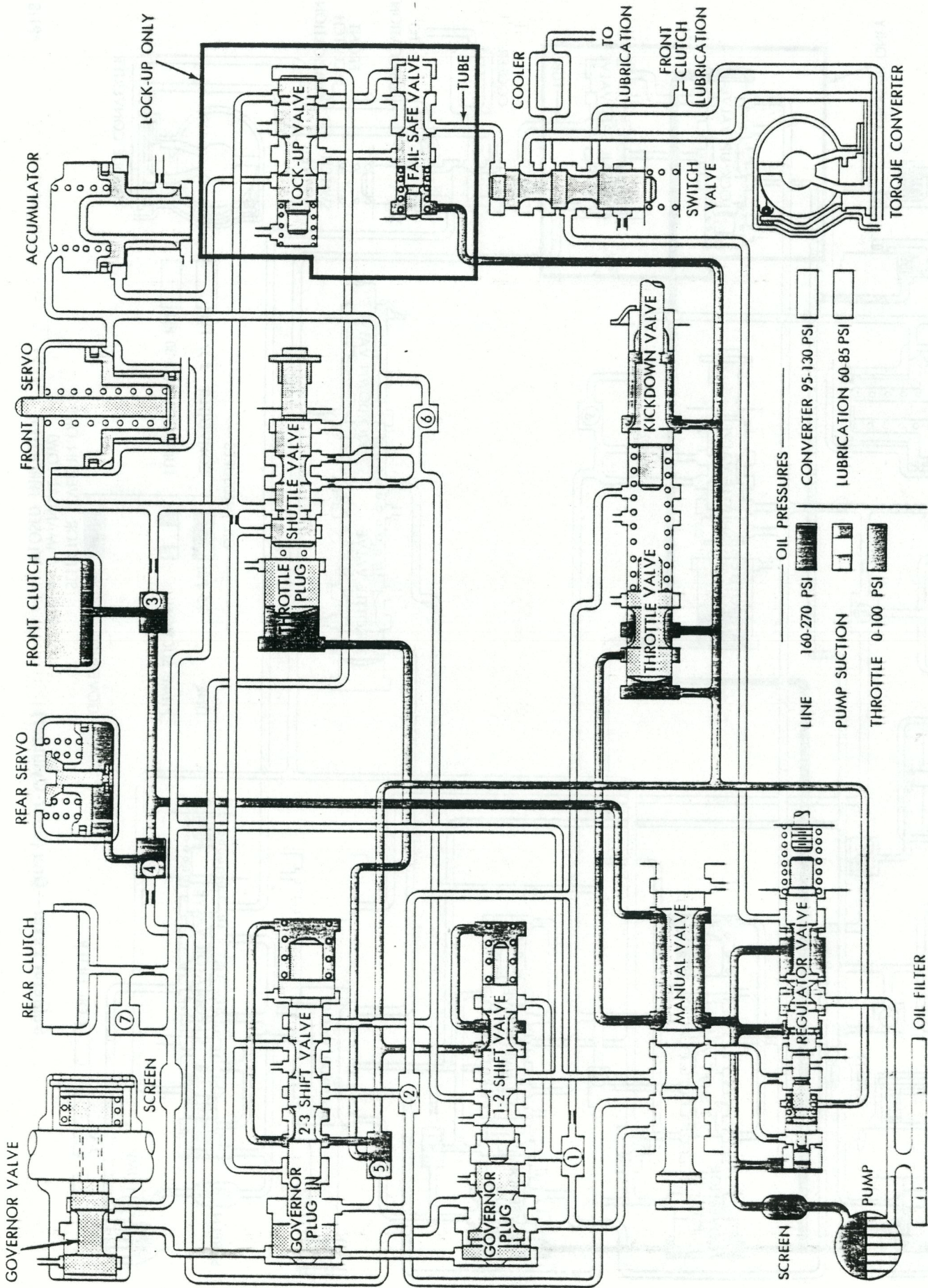

Reverse (Four-Cylinder)